

Nov. 20, 1951

C. M. VERHAGEN

2,575,854

SASH

Filed Oct. 21, 1946

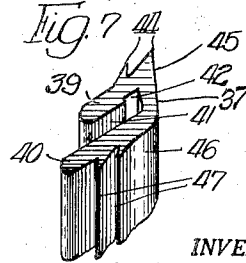
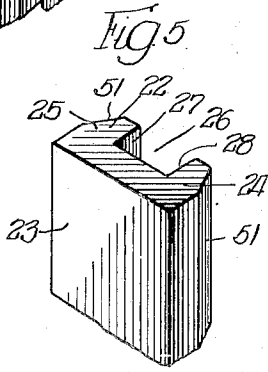
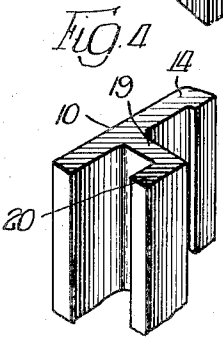
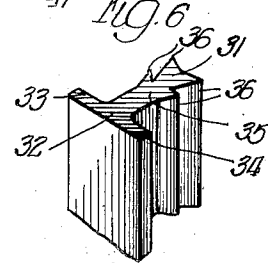
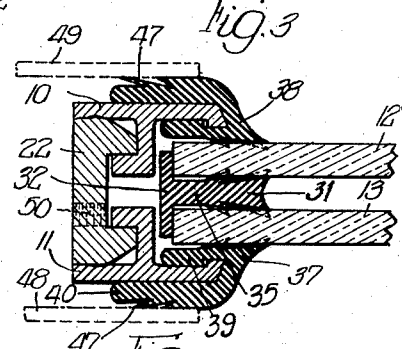
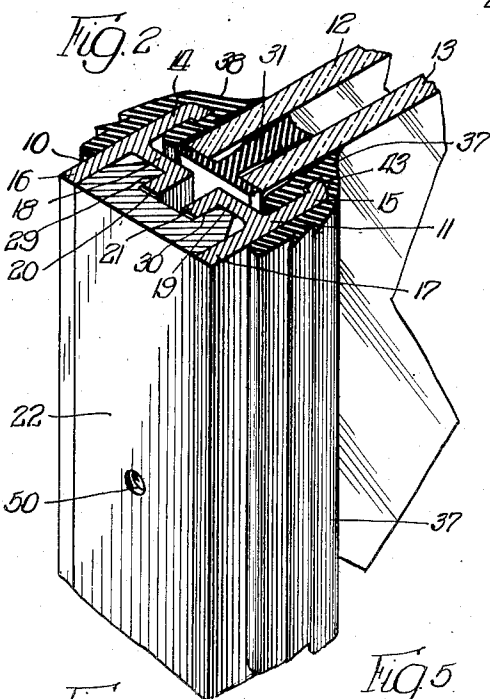
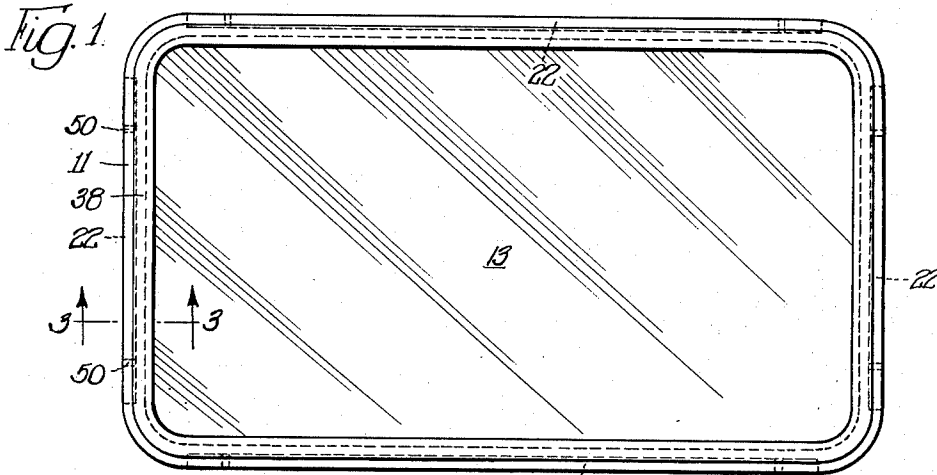

INVENTOR.
Christian M. Verhagen,
BY
Cromwell, Greist & Worden
attys.

UNITED STATES PATENT OFFICE

2,575,854

SASH

Christian M. Verhagen, Elkhart, Ind., assignor to
The Adlake Company, Chicago, Ill., a corpora-
tion of Illinois

Application October 21, 1946, Serial No. 704,553

2 Claims. (Cl. 189-64)

1

My invention is concerned with improvements in double glass sash construction of the type commonly used in the windows of air-conditioned railway cars, busses, airplanes and the like.

In sash construction of this nature the problem of mounting the glass in the frame of the sash is complicated by the varying thickness of the glass used. Commercial glass panes used for this purpose are found to vary in thickness as much as $\frac{1}{8}$ of an inch.

It is an object of my invention to provide a double glass sash construction which will accommodate panes of glass having some variation in thickness.

More specifically, it is an object of my invention to provide a double glass sash construction comprising a pair of generally rectangular rim members, which are positioned to form a frame having a channel-like recess for receiving and clamping the edges of the glass panes, fastening elements to hold the rim members in clamping position and resilient separator and glazing means positioned at the edges of the panes for spacing the edges of the panes from each other and from the rim members, wherein the rim members, the separator and glazing means are shaped and positioned to accommodate panes of varying thickness.

It is a further object of my invention to provide a double glass sash of the type described which when installed in an aperture in a vehicle wall will provide a window which is hermetically sealed irrespective of commercial variations in the thickness of the glass and in which the frame forming rim members are positioned between the inner and outer vehicle wall members with the glazing strips covering the normally exposed surfaces of said rim members.

It is another object of my invention to provide a novel sash construction which may be economically manufactured and which is readily and easily assembled and installed in a sash opening.

These and other objects will be apparent from the description of the preferred form of my invention, which is shown, by way of illustration, in the accompanying drawings, wherein:

Fig. 1 is a face view of a double glass sash constructed in accordance with my invention;

Fig. 2 is a perspective sectional view through one of the walls of the sash;

Fig. 3 is a transverse sectional view taken on the line 3-3 of Fig. 1;

Fig. 4 is a perspective sectional view through one of the rim members of the frame;

2

Fig. 5 is a perspective sectional view through one of the rim connection members;

Fig. 6 is a perspective sectional view through the edge spacing member; and

Fig. 7 is a perspective sectional view through one of the glazing strips.

The preferred form of my invention, as illustrated in the drawings, comprises a frame formed by complementary rim members 10 and 11, which are generally rectangular and which extend continuously around the edges of the two glass panes 12 and 13.

The rim members 10 and 11 are provided with inwardly extending flanges 14 and 15 and outwardly extending flanges 16 and 17, respectively. They are also provided with short laterally directed webs 18 and 19 and short outwardly directed flanges 20 and 21 at the confronting edges of the webs 18 and 19. The flanges 20 and 21 are spaced apart slightly in generally parallel relation to the median plane of the sash. The flanges 16, 17 and 20, 21, together with the webs 18, 19 form outwardly directed pockets to receive connecting blocks 22.

The connecting blocks 22 are provided on the four sides of the sash but do not extend around the curved corners of the same as indicated in Fig. 1. The connecting blocks 22 (Fig. 5) comprise a base portion 23 and inwardly extending side projections 24, 25, which form a central groove 26. The inwardly extending side projections 24 and 25 are received in the pockets formed between the flanges 16, 20 and 17, 21 of the rim members 10 and 11. The flange members 20 and 21 of the rim members 10 and 11 are received in the groove 26 of the connecting blocks 22. The inner faces 27 and 28 of the side projections 24, 25 of the connecting blocks 22 are in abutting, clamping relation with the facing seats 29 and 30 presented by the short flanges 20 and 21.

The glass panes 12 and 13 are separated at their edges by a spacing strip or separator 31, which is preferably of resilient material such as rubber. The strip 31 (Fig. 6) is inverted T-shaped in cross-section providing a base portion 32 having laterally extending flanges 33, 34, which are seated between the outer edges of the panes 12 and 13 and the webs 18 and 19 of rim members 10 and 11. The stem portion 35 is positioned between the panes 12 and 13 and is provided with angularly directed rib-like projections 36 on each face which engages the surface of the panes. When the strip is clamped in position between the panes 12 and 13 (Fig. 3)

3

the ribs 36 engage the surface of the panes some distance inwardly from the edge thereof.

The panes 12 and 13 are separated from the flanges 14 and 15 of the rim members 10 and 11 by means of glazing strips 37 and 38 as shown in Figs. 2 and 3. As illustrated particularly in Fig. 7, glazing strip 37 is generally U-shaped in cross-section and is provided with an inner leg 39 which is somewhat shorter than the outer leg 40. A recess 41 is formed between the legs 39 and 40 which is adapted to receive the flange 15 of the rim member 11. A lateral groove or recess 42 is provided in the leg 39 for cooperation with a laterally extending ridge or lip 43 on the flange 15 of the rim member 11 to position the strip 38 in interlocking relation with the rim member 11. The inner face of the leg 39 of the glazing strip 38 is provided with angularly outwardly projecting ridges 44, which are adapted to engage the surface of the pane 13 at a point spaced from the edge of the pane. The ridge members 44 are of the same character as the ridge members 36 on the spacing strip 31. When the sash is symmetrical as illustrated in Fig. 1 the glazing strips 37 and 38 may, of course, be identical in construction.

The ribs 36 on separator strip 31 and the ribs 44 on glazing strips 37 and 38 are initially angularly projecting, as shown in Figs. 6 and 7, and as indicated in dotted lines in Fig. 3. When the structure is assembled as shown in solid lines in Fig. 3, with the glass panes in position and the frame members 10 and 11 clamped together by the members 22, pressure is applied between the engaging portions of the members and the ribs 36 and 44 are flattened or distorted, so that the pressure is equalized. The panes 12 and 13 are firmly clamped between the flanges 14 and 15 of the rim members 10 and 11 by engagement of ridge members 36 and 44 with the surface of the glass and the pressure on the edges of the panes of glass is applied at points inwardly of such edges through the ridge members 36 and 44. With this construction they are better able to stand the sudden shocks and stresses which they are frequently subjected to in use.

The outer surface 45 of the bight portion of the U-shaped glazing strip 37 slopes outwardly and merges with the outer face 46 of the leg 40. The outer face 46 of the leg 40 is provided with angularly outwardly projecting ridge members 47.

The glazing strips 37 and 38 serve the dual purpose of spacing the glass panes 12 and 13 from the clamping flanges 14 and 15 of the rim members 10 and 11 and also of spacing the entire sash construction between the conventional flashing 48 and 49 (indicated in dotted line in Fig. 3) on the inside and outside of the vehicle wall in which the sash is mounted, the ridge members 47 engaging the inner surface of the flashing, as illustrated.

The glazing strips 37 and 38 cover the flanges 14 and 15 of the rim members 10 and 11 so that there are no exposed metal frame surfaces when the sash is installed in the vehicle wall. The metal frame members 10 and 11, the flashing 48 and 49 and the glass panes 12 and 13 are completely insulated from each other by the separator strip 31 and glazing strips 37 and 38 to provide an hermetically sealed window having low heat conductivity irrespective of commercial variations in the thickness of the glass panes 12 and 13.

In manufacturing the improved sash two assemblies may first advantageously be made—one

4

consisting of the rim members 10 and 11 with the glazing strips 37 and 38 applied to the flanges 14 and 15 of those rim members, and the other the two panes of glass, with the edge separator 31 applied between and about the margins of the same. This second assembly may then be inserted between the then rubber covered flanges 14 and 15 of the rim members, after which the connecting blocks 22 are positioned in clamped engagement with the short flanges 20 and 21 of the rim members. The connecting blocks 22 are held in clamping relation with the flanges 20 and 21 by the resiliency of the glazing strips after assembly of the sash members.

The connecting blocks 22 may be provided with spaced threaded holes 50, which are adapted to receive in threaded engagement a tool or threaded member by means of which they may be withdrawn from engagement with flanges 20 and 21 when it is desired to disassemble the sash. The side projections 24 and 25 of connecting members 22 may be beveled at 51 to facilitate their entry between the rim members 10 and 11. The width of the central groove 26 of the connecting members 22 may be varied whereby the sash may be adjusted to accommodate panes of glass of materially different thickness without any alteration in the size or shape of the frame members 10 and 11, the spacing member 31 or the glazing strips 37 and 38.

The glazing strips and spacing member for the glass may be made of any resilient material but they are preferably formed of molded rubber. The rim members 10 and 11 and the connecting members 22 may be made of any appropriate material but are preferably formed of light metal such as extruded aluminum.

While I have referred to specific materials and details of construction, it will be understood that other materials and details of construction may be used within the scope of my invention.

I claim:

1. In a double glass sash, two spaced panes of glass, rubber glazing means in which the edges of the panes are clamped, a frame surrounding the panes, said frame consisting of two laterally spaced separable rim members, each of which is characterized by a facing flange which extends inwardly in engagement with said glazing means, a web which extends laterally from the base of said facing flange toward the median plane of the sash, a facing flange which extends outwardly from said web, and a locking flange which also extends outwardly from said web in laterally spaced relation to said outwardly extending facing flange, and separable connecting members substantially coextensive with said locking flanges positioned between said outwardly extending facing flanges in clamped engagement with said locking flanges for holding said rim members with the inwardly extending facing flanges thereof in clamped engagement with said glazing means, said connecting members having substantially flat outer surfaces substantially flush with the outer edges of said outwardly extending flanges and having spaced apertures in said outer surfaces for receiving a tool to remove said members from clamped engagement with said locking flanges.

2. In a sash, one or more glass panes, rubber glazing means for the same, a metal frame in which the glazing means is mounted, said frame consisting of two laterally separable complementary rim sections, each of which is characterized by a facing flange which extends inwardly against one side of said glazing means, a web

5

which extends laterally from the base of said facing flange toward the median plane of the sash, a facing flange which extends outwardly from said web, and a locking flange which also extends outwardly from said web in laterally spaced relation to said outwardly extending facing flange, and elongate removable clamping members of generally U-shaped cross-section positioned between said outwardly extending facing flanges with the leg portions thereof in clamped engagement with said locking flanges for holding said rim sections with the inwardly extending facing flanges thereof in clamped engagement with said glazing means, said clamping members having the outer surface of the bight portions thereof substantially flush with the outer edges of said outwardly extending facing flanges and provided with spaced threaded apertures for cooperation with means to remove said member

6

from clamping engagement with said locking flanges.

CHRISTIAN M. VERHAGEN.

REFERENCES CITED

The following references are of record in the file of this patent:

UNITED STATES PATENTS

| Number | Name | Date |
|-----------|----------------|----------------|
| 2,157,425 | Nelson | May 9, 1939 |
| 2,162,463 | Schunk | June 13, 1939 |
| 2,169,713 | Stroud | Aug. 15, 1939 |
| 2,214,222 | Chaffee | Sept. 10, 1940 |
| 2,257,035 | Chaffee | Sept. 23, 1941 |
| 2,310,621 | Edwards et al. | Feb. 9, 1943 |
| 2,316,442 | Lootens | Apr. 13, 1943 |
| 2,329,567 | Verhagen | Sept. 14, 1943 |