



INTERNATIONAL APPLICATION PUBLISHED UNDER THE PATENT COOPERATION TREATY (PCT)

<p>(51) International Patent Classification ⁷ : G05D 1/02, E01C 19/00, E02F 3/84</p>	<p>A1</p>	<p>(11) International Publication Number: WO 00/10063 (43) International Publication Date: 24 February 2000 (24.02.00)</p>
<p>(21) International Application Number: PCT/US99/17325 (22) International Filing Date: 29 July 1999 (29.07.99) (30) Priority Data: 09/133,000 12 August 1998 (12.08.98) US (71) Applicant: CATERPILLAR INC. [US/US]; 100 N.E. Adams Street, Peoria, IL 61629-6490 (US). (72) Inventors: BRANDT, Everett, G.; 13604 N. Savage Road, Brimfield, IL 61517 (US). MCGEE, Robert, J.; 401 W. Clara Avenue, Peoria, IL 61614 (US). ROCKWOOD, Brian, D.; Apartment 2505, 5813 N. Lindenwood Dr., Peoria, IL 61615 (US). (74) Agents: KERCHER, Kevin, M. et al.; 100 N.E. Adams Street, Peoria, IL 61629-6490 (US).</p>	<p>(81) Designated States: AL, AM, AT, AU, AZ, BA, BB, BG, BR, BY, CA, CH, CN, CU, CZ, DE, DK, EE, ES, FI, GB, GD, GE, GH, GM, HR, HU, ID, IL, IN, IS, JP, KE, KG, KP, KR, KZ, LC, LK, LR, LS, LT, LU, LV, MD, MG, MK, MN, MW, MX, NO, NZ, PL, PT, RO, RU, SD, SE, SG, SI, SK, SL, TJ, TM, TR, TT, UA, UG, UZ, VN, YU, ZW, ARIPO patent (GH, GM, KE, LS, MW, SD, SL, SZ, UG, ZW), Eurasian patent (AM, AZ, BY, KG, KZ, MD, RU, TJ, TM), European patent (AT, BE, CH, CY, DE, DK, ES, FI, FR, GB, GR, IE, IT, LU, MC, NL, PT, SE), OAPI patent (BF, BJ, CF, CG, CI, CM, GA, GN, GW, ML, MR, NE, SN, TD, TG).</p> <p>Published <i>With international search report. Before the expiration of the time limit for amending the claims and to be republished in the event of the receipt of amendments.</i></p>	

(54) Title: METHOD AND APPARATUS FOR DETERMINING A PATH TO BE TRAVERSED BY A MOBILE MACHINE

(57) Abstract

In one embodiment of the present invention, an apparatus and method for determining a path (22) or series of paths at a work site (20) for a mobile machine (28) capable of operating autonomously or semi-autonomously is provided. The present invention determines a series of rows that are substantially parallel to the machine's (28) heading. The width of the rows is based on the width of the path (22) worked by one or more of the machine's (28) work implements. The work site (20) is bounded by three or more corner points and the perimeter (24) of the work site (20) is defined by boundary lines connecting the corner points. A first line (108) substantially perpendicular to the machine's (28) heading is calculated starting at an initial corner point and ending at a terminal point (106) along the line (108) having a distance approximately equal to the width of the path (22). A second line parallel to the machine's (28) heading and passing through the terminal point (106) is determined. The points of intersection of the second line with the boundary lines are calculated and stored as end points (104) of a first path (22). End-points (104) of successive paths (22) are found in a similar manner by incrementing the distance along the parallel line by the width of the work path (22).

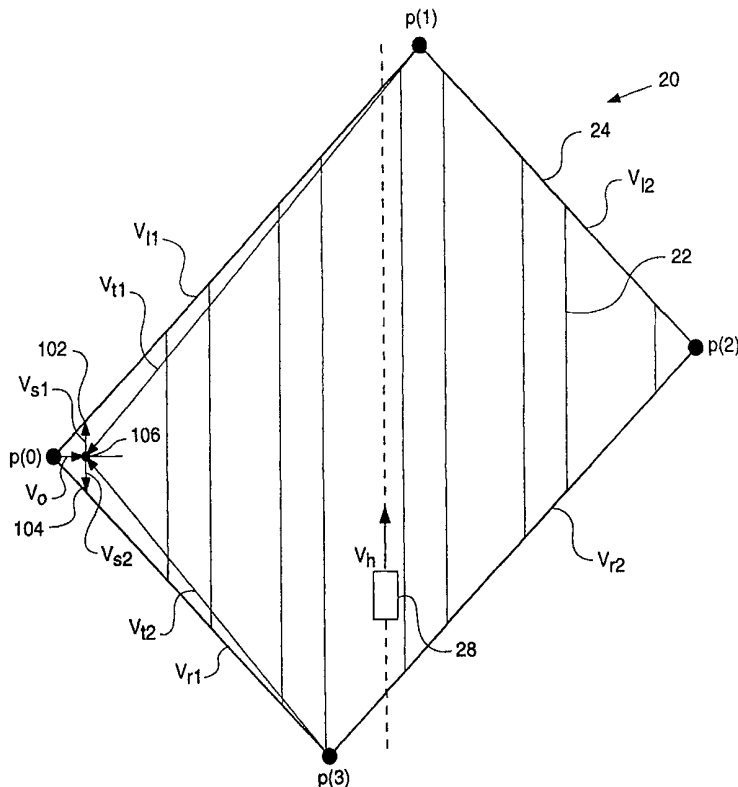

FOR THE PURPOSES OF INFORMATION ONLY

Codes used to identify States party to the PCT on the front pages of pamphlets publishing international applications under the PCT.

AL	Albania	ES	Spain	LS	Lesotho	SI	Slovenia
AM	Armenia	FI	Finland	LT	Lithuania	SK	Slovakia
AT	Austria	FR	France	LU	Luxembourg	SN	Senegal
AU	Australia	GA	Gabon	LV	Latvia	SZ	Swaziland
AZ	Azerbaijan	GB	United Kingdom	MC	Monaco	TD	Chad
BA	Bosnia and Herzegovina	GE	Georgia	MD	Republic of Moldova	TG	Togo
BB	Barbados	GH	Ghana	MG	Madagascar	TJ	Tajikistan
BE	Belgium	GN	Guinea	MK	The former Yugoslav Republic of Macedonia	TM	Turkmenistan
BF	Burkina Faso	GR	Greece			TR	Turkey
BG	Bulgaria	HU	Hungary	ML	Mali	TT	Trinidad and Tobago
BJ	Benin	IE	Ireland	MN	Mongolia	UA	Ukraine
BR	Brazil	IL	Israel	MR	Mauritania	UG	Uganda
BY	Belarus	IS	Iceland	MW	Malawi	US	United States of America
CA	Canada	IT	Italy	MX	Mexico	UZ	Uzbekistan
CF	Central African Republic	JP	Japan	NE	Niger	VN	Viet Nam
CG	Congo	KE	Kenya	NL	Netherlands	YU	Yugoslavia
CH	Switzerland	KG	Kyrgyzstan	NO	Norway	ZW	Zimbabwe
CI	Côte d'Ivoire	KP	Democratic People's Republic of Korea	NZ	New Zealand		
CM	Cameroon			PL	Poland		
CN	China	KR	Republic of Korea	PT	Portugal		
CU	Cuba	KZ	Kazakstan	RO	Romania		
CZ	Czech Republic	LC	Saint Lucia	RU	Russian Federation		
DE	Germany	LI	Liechtenstein	SD	Sudan		
DK	Denmark	LK	Sri Lanka	SE	Sweden		
EE	Estonia	LR	Liberia	SG	Singapore		

DescriptionMETHOD AND APPARATUS FOR DETERMINING A PATH TO BE
TRAVERSED BY A MOBILE MACHINE

5

Technical Field

The present invention relates generally to the operation of a mobile machine for traversing an area of a work site and, more particularly, to a method and apparatus for determining a set of paths to be traversed by a mobile machine.

As used in this patent specification the phrase "mobile machinery" and various approximations thereof refer to self-propelled machines such as track-type tractors, road graders, pavers, asphalt layers, agricultural machinery, compactors, lawnmowers, and the like, which exhibit both (1) mobility over or through a work site, and (2) the capacity to alter the topography or appearance of a work site with a tool or operative portion of the machine such as a bucket, shovel, blade, ripper, compacting wheel and the like.

Background

There is an increasing demand to automate mobile machinery that traditionally requires a human operator. There are several reasons for this. Unlike a human operator, automated machinery remains consistently productive regardless of environmental conditions and prolonged work hours. Automated machinery is also ideal for applications where

conditions are unsuitable or undesirable for humans. Further, automated machinery enables more accurate operation and compensates for lack of operator skill.

The work cycles of different types of
5 machines may include similar requirements. Some mobile machines, including earth, asphalt, and trash compactors, repeatedly traverse a site until the material is compressed to the desired degree. Other types of mobile machines, such as lawn mowing
10 machinery, traverse an area only once during a work cycle. During autonomous operation, these machines require means to determine their position, the area to be traversed, an optimal path to follow while traversing the area, and means to control their
15 movement while traversing the path.

In the prior art, a site survey is typically conducted manually using line-of-sight optical instruments or other static, point by point measuring techniques. Thereafter, the site is carefully marked
20 with stakes to provide visual cues to the operator of the machinery. Systems for achieving a desired degree of compaction or desired site topography with mobile terrain-shaping and material compacting machinery are disclosed in U.S. Patent Nos. 5,631,658; 5,493,494;
25 5,471,391; and 5,646,844. In these patents, the actual site topography is determined on a continual basis using a global positioning system on the machine to provide information regarding the position of the machine in space. Using the position of the machine,
30 the actual topography of the terrain is updated as the machine traverses the work site and the difference

between the actual site topography and the desired site topography is determined on a continual basis. The areas where there are differences between the desired and the actual site topography indicate areas where work still needs to be done with the machine. This information is provided to an operator via a real-time graphical display to provide visual cues for operating the machine over a work site. The prior art methods do not, however, disclose means for determining the path or set of paths to be used by a mobile machine that is capable of traversing the work area autonomously. Further, with autonomous machinery, the series of paths must be provided in a manner that is usable by a computer-based planning and navigation system that determines how to steer the machine to follow the paths and how to transition the machine from one path to the next.

Accordingly, the present invention is directed to overcoming one or more of the problems as set forth above.

Disclosure of the Invention

In one embodiment of the present invention, an apparatus and method for determining a path or series of paths at a work site for a mobile machine capable of operating autonomously or semi-autonomously includes computing the heading of the machine by taking two or more position readings using a positioning system as the machine moves in a particular direction. The present invention determines a series of rows that are substantially

parallel to the machine's heading. The width of the rows is based on the width of the path worked by one or more of the machine's work implements. The work site is bounded by three or more corner points and the perimeter of the work site is defined by boundary lines connecting the corner points. A first line substantially perpendicular to the machine's heading is calculated starting at an initial corner point, and ending at a terminal point along the line having a distance approximately equal to the width of the path. The initial corner point is typically the corner point furthest to the left of the machine. A second line parallel to the machine's heading and passing through the terminal point is determined. The points of intersection of the second line with the boundary lines are calculated and stored as end points of a first path. Endpoints of successive paths are found in a similar manner by incrementing the distance along the perpendicular line by the width of the work path. The cross product of a pair of vectors having orientation and position based on the terminal point is used to determine when the paths extend beyond corner points adjacent to the initial corner point. When this occurs, adjacent boundary lines are used to determine the end points of each path.

Brief Description of Drawings

Fig. 1 is a top plan view of a work area having a plurality of work paths;

Fig. 2 is a functional block diagram of a sensor system for providing position data;

Fig. 3 is a functional block diagram used to carry out the present invention including a control system for a mobile machine;

Fig. 4a is a perspective view of a wheeled compactor which may utilize the present invention;

Fig. 4b is a diagrammatic representation of a series of paths for the wheeled compactor to traverse as determined by the present invention;

Fig. 5a is a perspective view of a single roll compactor which may utilize the present invention;

Fig. 5b is a diagrammatic representation of a series of paths for the single roll compactor to traverse as determined by the present invention;

Fig. 6a is a perspective view of a track-type tractor which may utilize the present invention;

Fig. 6b is a diagrammatic representation of a series of paths for the track-type tractor to traverse as determined by the present invention;

Fig. 7 is a diagrammatic representation of the vector components used to determine one of the paths for the wheeled compactor;

Fig. 8 is a diagrammatic representation of the vector components used to determine another one of the paths for the wheeled compactor;

Fig. 9 is a diagrammatic representation of the vector components used to determine another one of the paths for the wheeled compactor; and

Fig. 10 is a diagrammatic representation of the vector components used to determine another one of the paths for the wheeled compactor.

Best Mode for Carrying Out the Invention

Referring to Fig. 1, a top plan view of a work area 20 is shown having a plurality of paths 22 bounded by a perimeter 24. A cushion boundary 26 is included between paths 22 and the perimeter 24 so that small inaccuracies in data provided by sensor systems do not interfere with the present invention as described hereinbelow. The paths 22 are exemplary of the manner in which the work area 20 may be divided where a task such as material compacting or lawn mowing is performed by a mobile machine 28. It should be noted that a wide variety of patterns may be used to divide the work area 20 into paths 22. Some factors for selecting a particular pattern include the area covered during one pass of the mobile machine 28, the turning radius of the mobile machine 28, and the size of the work area 20. The present invention is applicable to tasks that involve traversing the work area 20 only once, such as lawn mowing, or several times, such as material compaction.

The present invention includes means to generate signals representing the instantaneous position in at least two-dimensional space of a portion of the mobile machine 28. Such means, as shown in Fig. 2, includes a vehicle positioning system 30 capable of providing information regarding the position of the mobile machine 28 in two-dimensional or three-dimensional space. Several different types of sensors 32 are suitable for use in such positioning systems 30 including, but not limited to, inertial

-7-

gyros, lasers, global positioning systems (GPS), GPS/laser combinations, and radar. In certain types of positioning systems 30, such as the GPS satellite 34 shown in Fig. 1, position data is transmitted to a receiver 38. The receiver 38 is in communication with a sensor processing module 46 that provides sensor data to control system computer 40 as shown in control system 42 in Fig. 3.

The control system computer 40 includes a data processor, such as a microprocessor, random access memory, read only memory, and a data bus for receiving data from and transmitting data to various devices. The control system computer 40 executes logic and equations implemented in one or more software programs to determine actuator position command signals for operating various pumps, valves, hydraulic cylinders, motor/steering mechanisms and other servo-actuated controls for controlling movement of the mobile machine 28. Servo-actuators 44 receive position commands but typically are not capable of moving to the commanded position instantaneously. Actual actuator positions are sensed and input to the sensor processing module 46 that conditions the sensor signals for use by the control system software programs. The position data of the mobile machine 28 from the positioning system 30 as well as data from other sensors 48 may also be conditioned by the sensor processing module 46, which filters noise from the signals and performs any other processing required. The sensor processing module 46 may be implemented in software that is executed a computer, such as the

control system computer 40, or it may be implemented with electronic circuitry. Sensed parameters from the sensor processing module 46 are input to the control system computer 40 for use by the software programs.

5 The mobile machines 28 such as the compactors 50, 74, and the tractor 86 are capable of autonomous or semi-autonomous operation using an electro-hydraulic control system 42 as shown in Fig. 3. These controls operate, for example, steering,
10 brake, throttle, blade, and motor controls. The mobile machines 28 are equipped with a positioning system capable of dynamically determining the position of the machine with a high degree of accuracy as it traverses the work area 20. In a preferred
15 embodiment, aspects of the method and apparatus of the present invention are realized through utilization of three-dimensional position information derived from a GPS sensor system using a phase differential GPS receiver. Such GPS receivers utilize signals
20 generated by global positioning satellites as well as a differential signal from a base station having a reference receiver of known position coordinates to generate position coordinate data to within known accuracy.

25 Referring to Figs. 4a through 6b, examples of different types of mobile machines 28 and the corresponding footprints of their work implements are shown. Fig. 4a is a landfill compacting machine 50 and Fig. 4b represents the footprint of two front
30 wheels 52, 54. The front wheels 52, 54 and rear wheels 56, 58 are the work implements of compactor 50

as the wide, studded surfaces are capable of compacting waste and trash in a landfill in known fashion. Compactor 50 is heavy, and may be weighted to increase the compacting force exerted by the wheels 52, 54, 56, 58 on the material over which they traverse. In Fig. 4b, a space 60 is shown between the front wheels 52, 54 of compactor 50. When the compactor 50 traverses the work area 20, the material in the space 60 between the wheels 52, 54 is not compacted. In order to compact the uncompact area during a subsequent pass, the wheels on the left or right side of the compactor must overlap the space 60. One pattern for accomplishing this is shown by a set of four paths 62, 64, 66, 68 in Fig. 4b, where the compactor follows path 64 to overlap the space 60 so that wheel 54 compacts the space 60 left by the compactor 50 as it traverses path 62. After traversing path 64, the compactor 50 traverses path 66, once again leaving space 60 between wheels 52 and 54. Path 68 is planned so that wheel 54 overlaps the space 60. The distance between alternating paths 62, 64, 66, 68 thus varies between a short distance 70 and a long distance 72. This pattern is useful when the space is less than or equal to the width of one of the work implements.

Fig. 5a shows another type of compactor 74 with a work implement consisting of a large, weighted roller 76. Fig. 5b represents the footprint of the roller 76 on three parallel paths 78, 80, 82. The distance 84 between the paths 78, 80, 82 is approximately equivalent to the width of roller 76 and

remains the same since no space 60 is left between the work implement. This pattern of paths is applicable to any type of mobile machine 28 having a work implement that typically does not leave an area untouched as it traverses the path, such as a lawn mower.

Fig. 6a shows an example of track-type tractor 86 having a space 88 between tracks 90, 92 that is greater than the width of one track 90 or 92. Fig. 6b shows a series of paths 94, 96, 98, 100 that may be used when the tracks 90, 92 are used as work implements, such as compacting material. In this situation, at least two paths must be planned to cover the space 88 as shown in Fig. 6b by paths 94, 96, and 98. The distance between paths 94 and 96, and paths 96 and 98 is less than or equal to the width of the tracks 90 or 92. The distance between paths 98 and 100 is equal to the width of the tractor 86.

Figs. 4b, 5b, and 6b are examples of patterns of paths that may be planned for various types of mobile machines 28. Other mobile machines 28 having different configurations of work implements may be used with the present invention as long as information regarding the number of work implements and the widths of the work implements is provided. Further, the widths of the work implements do not have to be the same, as the present invention will take into account the area covered by each work implement and plan accordingly.

In one embodiment, the present invention for a method for determining the path 22 or series of

-11-

paths in work area 20 bounded by perimeter 24, as shown in Fig. 7, involves determining the heading of the paths 22 based on the heading of the mobile machine 28, and determining the distance between adjacent paths 22 based on the width of one or more work implements on the mobile machine 28. Endpoints 102, 104 of the path, based on the location of corner points $p(0)$, $p(1)$, $p(2)$, and $p(3)$ of perimeter 24, the width of the mobile machine 28, and the width of one or more work implements, is then determined. Vectors v_h , v_o , v_{t1} , v_{s1} , v_{t2} , v_l , v_r , and v_{s2} are used to determine path 22. Vector v_h is the heading vector of the mobile machine 28.

Vector v_o is a vector substantially perpendicular to the heading vector v_h , with an origin at corner point $p(0)$. The corner point $p(i)$ that is furthest to the left of the mobile machine 28 is typically chosen as origin $p(0)$, however, the corner point furthest to the right of the mobile machine 28 may also be used if corresponding changes are made to the present invention to take the change into account. If the leftmost corner point is chosen, the other corner points are designated, in clockwise direction from $p(0)$ as $p(1)$, $p(2)$, $p(3)$, up to $p(n)$, where n is the total number of corner points around perimeter 24. Note that the perimeter 24 may include any number of corner points $p(n)$. The initial length of v_o is approximately equal to the distance from the origin $p(0)$ to one-half of the width of the mobile machine 28. To compute the endpoints 102, 104 for subsequent paths 22, the length of v_o is incremented in the same

-12-

direction by the distance to the next path 22 to a new terminal point 106 as shown in Fig. 8. The distance between paths 22 is computed based on the pattern of the paths 22, the width and number of implements, and the space between the implements, as described for the examples of patterns in Figs. 4a through 6b hereinabove.

Once the direction and length and terminal point 106 of v_0 is determined for a particular path 22, the next step is to determine a line 108 through the terminal point 106 of vector v_0 , where the line 108 is substantially parallel to the heading of the mobile machine 28 and intersects one side of the perimeter 24 at starting point 102 and another side of the perimeter 24 at ending point 104 of the path 22. The starting point 102 and ending point 104 of each path 22 is stored in memory connected to the control system computer 40. In the preferred embodiment, the points of intersection of the line 108 with the perimeter 24 of the work area 20 are found using vectors v_0 , v_1 , v_r and the distance l between the paths 22. Knowing the direction and length of vectors v_0 , v_1 , and v_r , the projection of v_0 on vectors v_1 and v_r is calculated as is well known, and the endpoints of the projections are recorded as the endpoints 102, 104 of line 108.

Alternatively, the points of intersection of the line 108 with the perimeter 24 of the work area 20 may be found using the Cartesian coordinate system and the coordinates of the corner points to calculate equations for the sides of the perimeter 24, and then

-13-

finding the x-coordinate of the intersection point by solving the following equation:

$$x = (b_1 - b_2) / (m_2 - m_1)$$

5

where b_1 and b_2 are the y-intercepts of the lines and m_1 and m_2 are the slopes of the lines. Once the x-coordinate of the intersection point is found, it is used in the formula for one of the lines to solve for the y-coordinate as follows:

$$y = mx + b$$

where m is the slope m_1 or m_2 , b is the corresponding y-intercept b_1 or b_2 , and x is the x-coordinate of the intersection point. These calculations are then repeated for line 108 and a line for the other side of the perimeter 24 which intersects line 108.

20

Vectors v_{t1} , v_{s1} , v_{t2} , and v_{s2} are used to determine when the vector v_o has been incremented to a terminal point 106 where the starting point 102 and/or ending point 104 of line 108 intersect a different boundary of the perimeter 24 than the previous boundary. Vectors v_{s1} and v_{s2} are substantially parallel to the heading of the mobile machine 28, each having an origin at the terminal point 106 of vector v_o . For a perimeter with four corner points, the initial origin of vector v_{t1} is the corner point $p(1)$ and the terminal point of v_{t1} is at the terminal point 106 of the vector v_o . The vector cross product of v_{t1}

30

-14-

and v_{s1} is calculated as is known, and the sign of the cross product is used to determine left and right boundary vectors v_l and v_r to use to calculate the start point and the end point of the next path. In the example shown in Fig. 7, if the sign of the cross product v_{t1} and v_{s1} is negative, then the boundary vector v_l between corner points $p(0)$ and $p(1)$ is used. If the sign of the cross product is positive, then boundary vector v_{l2} between corner points $p(1)$ and $p(2)$ is used.

A similar test using vectors v_{t2} and v_{s2} is performed to check the right boundary. For a perimeter with four corner points, the initial origin of vector v_{t2} is the corner point $p(3)$ and the terminal point of v_{s2} is at the terminal point 106 of the vector v_o . The vector cross product of v_{t2} and v_{s2} is calculated as is known, and the sign of the cross product is used to determine the right boundary vector to use to calculate the start point and the end point of the next path 22. If the sign of the cross product is negative, then the boundary vector v_r between corner points $p(0)$ and $p(3)$ is used. If the sign of the cross product is positive, then boundary vector v_{r2} between corner points $p(3)$ and $p(2)$ is used.

Fig. 8 shows vectors v_{t1} and v_{s1} whose cross product is negative and Fig. 9 shows vectors v_{t1} and v_{s1} whose cross product is positive. In Fig. 9, line 108 intersects vector v_{l2} between points $p(1)$ and $p(2)$ and vector v_{r2} between points $p(2)$ and $p(3)$. When the cross product between vectors v_{r1} and v_{s1} is positive, the cross product indicates that a subsequent left

boundary vector v_{12} should be used to calculate the endpoint 102 of line 108. When the cross product between vectors v_{t2} and v_{s2} is positive, the cross product indicates that a subsequent right boundary

5 vector v_{r2} should be used to calculate endpoint 104 of line 108. When new boundary vectors v_{12} , v_{r2} are used, the endpoints 102, 104 must be found by taking into account the distance along the old boundary vectors v_{11} and v_{r1} and calculating the remaining distance along

10 the new boundary vectors v_{12} and v_{r2} . This is calculated by determining the projection of the vector v_o on the old boundary vectors v_{11} and v_{r1} , determining the overshoot of v_o past v_{11} and projecting the overshoot onto the next boundary vector v_{12} .

15 The steps of incrementing v_o to the next path 22, determining line 108 through the terminal point 106 of vector v_o , calculating the cross product of vectors (v_{t1}, v_{s1}) and (v_{t2}, v_{s2}) , and computing the endpoints of line 108, are repeated until the next

20 path 22 is outside the perimeter 24 of work area 20.

The present invention is applicable to other situations where the perimeter 24 has three or more corner points, such as the perimeter in Fig. 10 having five corner points wherein $p(0)$ is the corner point

25 furthest to the left of the mobile machine 28, and the other corner points are numbered consecutively in the clockwise direction. The work area 20 may have any shape as dictated by factors such as property boundaries or area in which the task is to be

30 performed. The work areas 20 shown herein are for illustrative purposes only and are not meant to limit

the present invention to work areas having a particular shape or number of boundary points.

Industrial Applicability

5 The present invention for establishing the perimeter 24 of the work area 20 may be advantageously used in a system for autonomous control of a mobile machine 28. The principles and applications of the present invention lend themselves to virtually any
10 mobile machine 28 that traverses a work area 20 while performing a task. Such mobile machinery may be equipped in known fashion with an electro-hydraulic control system 42 as discussed hereinabove. The control system 42 for autonomous mobile machinery
15 includes several software programs that may be executed in the control system computer 40. These software programs include a work planner for generating paths 22, a path planner for planning transitions between the paths 22, and a path follower
20 for determining which way to steer the mobile machine 28 to follow the paths 22. These software programs require knowledge regarding the perimeter 24 of the work area 20 for various reasons including to avoid trespassing on another's property or to avoid
25 operating the mobile machine 28 in undesirable areas such as near the edge of cliffs, lakes, or obstacles. The control system 42 may also generate the cushion boundary 26 once the perimeter 24 is established which provides a further buffer in the event that sensor
30 system 30 provides position data containing errors due to inaccuracies in the sensor system 30.

-17-

Other aspects, objects and advantages of the present invention can be obtained from a study of the drawings, the disclosure and the appended claims.

Claims

1. A method for determining a path (22) for a mobile machine (28) to follow in a work area (20) bounded by a perimeter (24) having a plurality of corner points, the method comprising the steps of:
- (a) determining the heading of the path based (22) on the heading of the mobile machine (28);
 - (b) calculating a vector substantially perpendicular to the heading of the mobile machine (28);
 - (c) determining the distance between adjacent paths (84) based on the width of a work implement on the mobile machine (28); and
 - (d) determining a start point (102) and an end point (104) of the path (22) based on the location of the corner points, the perimeter (24) of the work area (20) , and the width of the work implement.
2. The method, as set forth in claim 1, wherein the vector has an origin at a corner point adjacent one side of the mobile machine (28) and a length proportional to the width of the work implement.
3. The method, as set forth in claim 2, wherein step (d) further comprises determining a line (108) through the terminal point (106) of the vector, the line (108) being substantially parallel to the heading of the mobile machine (28) and intersecting two sides of the perimeter (24), one point of intersection being the start point (102) of the path

and the other point of intersection being the end point (104) of the path (22).

24. A method for determining a series of
- 5 paths (22) for a mobile machine (28) to follow in a work area (20), the work area (20) being bounded by a multi-sided perimeter (24) having a plurality of corner points, the method comprising the steps of:
- (a) determining the heading of the paths
- 10 based (22) on the heading of the mobile machine (28);
- (b) determining the width of a path (22) based on the width of a work implement on the mobile machine (28);
- (c) calculating a first vector
- 15 substantially perpendicular to the heading of the mobile machine (28), the terminal point (106) of the first vector being at a distance proportional to the width of the path (22) and the origin of the first vector being at the corner point adjacent the left
- 20 side of the mobile machine (28) having the furthest distance from the mobile machine (28);
- (d) determining a start point (102) and an end point (104) for the path (22) based on the location of the corner points, the perimeter (24) of
- 25 the work area (20), and the first vector;
- (e) incrementing the terminal point (106) of the first vector perpendicular to the heading of the mobile machine (28) by the distance to an adjacent path (22) in the series of paths (22);
- 30 (f) calculating a second vector substantially parallel to the heading of the mobile

-20-

machine (28), the second vector having an origin at the terminal point (106) of the first vector;

(g) calculating a third vector, the origin of the third vector being at the corner adjacent the furthest corner point in the clockwise direction and the terminal point (106) of the third vector being at the terminal point (106) of the first vector;

(h) calculating the vector cross product of the second and the third vectors;

(i) using the sign of the cross product to determine the side of the perimeter (24) to use to calculate the start point (102) and the end point (104) of the next path (22);

(j) determining a start point (102) and an end point for the next path (22) based on the terminal point (106) of the vector and the perimeter (24) of the work area (20);

(k) repeating steps (e) through (j) until the next path (22) is outside the perimeter (24) of the work area (20).

5. The method, as set forth in claim 4, wherein step (d) further comprises determining a line (108) through the terminal point (106) of the first vector, the line (108) being substantially parallel to the heading of the mobile machine (28) and intersecting two sides of the perimeter (24), one point of intersection being the start point (102) of the path (22) and the other point of intersection being the end point (104) of the path (22).

-21-

6. The method, as set forth in claim 4, wherein step (j) further comprises determining a line (108) through the terminal point (106) of the first vector, the line (108) being substantially parallel to the heading of the mobile machine (28) and intersecting two sides of the perimeter (24), one point of intersection being the start point (102) of the next path (22) and the other point of intersection being the end point (104) of the next path (22).

10

7. An apparatus for determining a path (22) for a mobile machine (28) to follow in a work area (20) bounded by a perimeter (24) having a plurality of corner points, the apparatus comprising:

15 a positioning system (30) for providing position data for the mobile machine (28);

a data processor in communication with the positioning system (30), the data processor being operable to determine the heading of the mobile machine (28) based on data from the positioning system (30);

20 the data processor being further operable to determine the heading of the path (22) based on the heading of the mobile machine (28);

25 the data processor being further operable to determine the width of the path (22) based on the width of a work implement on the mobile machine (28);

and

the data processor being further operable to determine a start point (102) and an end point (104) of the path (22) based on the location of the corner

30

-22-

points, the perimeter (24) of the work area (20), and the width of the work implement.

8. The apparatus, as set forth in claim 7,
5 wherein the data processor is further operable to determine the start point (102) and the end point (104) of the path (22) by calculating a vector substantially perpendicular to the heading of the mobile machine (28), the vector having a length
10 proportional to the width of the path (22) and an origin at one of the corner points adjacent one side of the mobile machine (28).

9. The apparatus, as set forth in claim 8,
15 wherein the data processor is further operable to determine a line (108) through the terminal point (106) of the vector, the line (108) being substantially parallel to the heading of the mobile machine (28) and intersecting two sides of the
20 perimeter (24), one point of intersection being the start point (102) of the path (22) and the other point of intersection being the end point (104) of the path (22).

25 10. An apparatus for determining a series of paths (22) for a mobile machine (28) to follow in a work area, the work area (20) being bounded by a multi-sided perimeter (24) having a plurality of corner points, the apparatus comprising:

30 a data processor in communication with a positioning system (30), the positioning system (30) providing data on the position, speed, and heading of the mobile machine (28), the data processor being

-23-

operable to determine the heading of the paths (22)
based on the heading of the mobile machine (28);

the data processor being further operable to
determine the width of a path (22) based on the width
5 of a work implement on the mobile machine (28);

the data processor being further operable to
calculate a first vector substantially perpendicular
to the heading of the mobile machine (28), the
terminal point (106) of the first vector being at a
10 distance proportional to the width of the path (22)
and the origin of the first vector being at the corner
point adjacent the left side of the mobile machine
(28) having the furthest distance from the mobile
machine (28);

15 the data processor being further operable to
determine a start point (102) and an end point (104)
for the path (22) based on the location of the corner
points, the perimeter (24) of the work area (20), and
the first vector;

20 the data processor being further operable to
repeatedly increment the terminal point (106) of the
first vector perpendicular to the heading of the
mobile machine (28) by the width of a next path (22)
in the series of paths, to calculate a second vector
25 substantially parallel to the heading of the mobile
machine (28), the second vector having an origin at
the terminal point (106) of the first vector, to
calculate a third vector, the origin of the third
vector being at the corner adjacent the furthest
30 corner point in the clockwise direction and the
terminal point (106) of the third vector being at the

-24-

terminal point (106) of the first vector, to calculate the vector cross product of the second and the third vectors, to determine the side of the perimeter (24) to use to calculate the start point (102) and the end point (104) of the next path (22) using the sign of the cross product, to determine a start point (102) and an end point (104) for the next path (22) based on the terminal point (106) of the vector and the perimeter (24) of the work area (20), until the next path (20) is outside the perimeter (24) of the work area (20).

11. The apparatus, as set forth in claim 10, wherein the data processor is further operable to determine a line (108) through the terminal point (106) of the first vector, the line (108) being substantially parallel to the heading of the mobile machine (28) and intersecting two sides of the perimeter (24), one point of intersection being the start point (102) of the path (22) and the other point of intersection being the end point (104) of the path (22).

12. The apparatus, as set forth in claim 10, wherein the data processor is further operable to determining a line (108) through the terminal point (106) of the first vector, the line (108) being substantially parallel to the heading of the mobile machine (28) and intersecting two sides of the perimeter (24), one point of intersection being the start point (102) of the next path (22) and the other point of intersection being the end point (104) of the next path (22).

FIG. 1

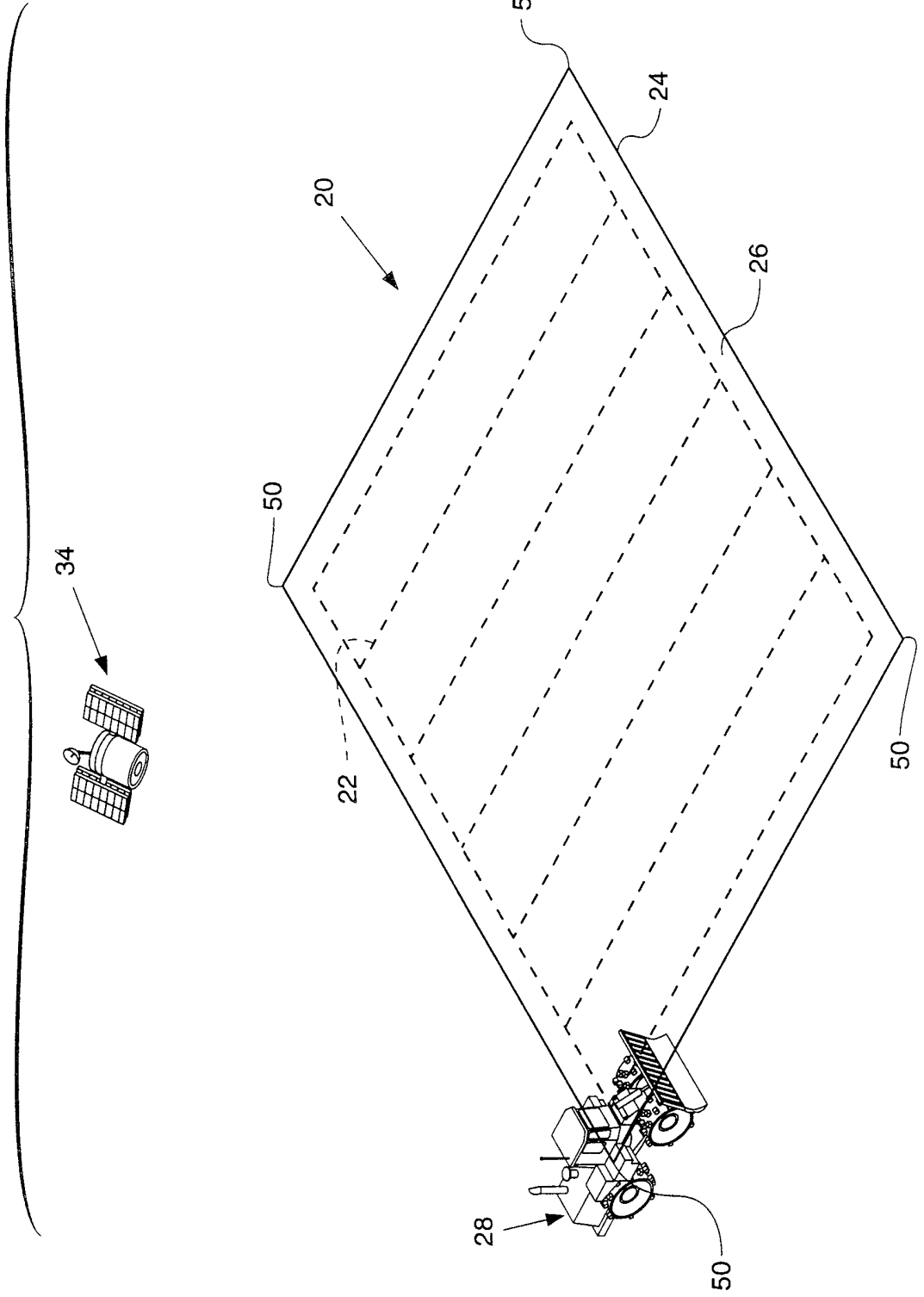

FIG - 2 -

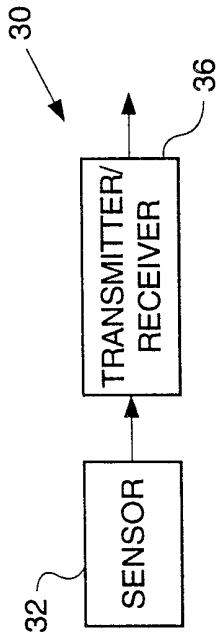

FIG - 3 -

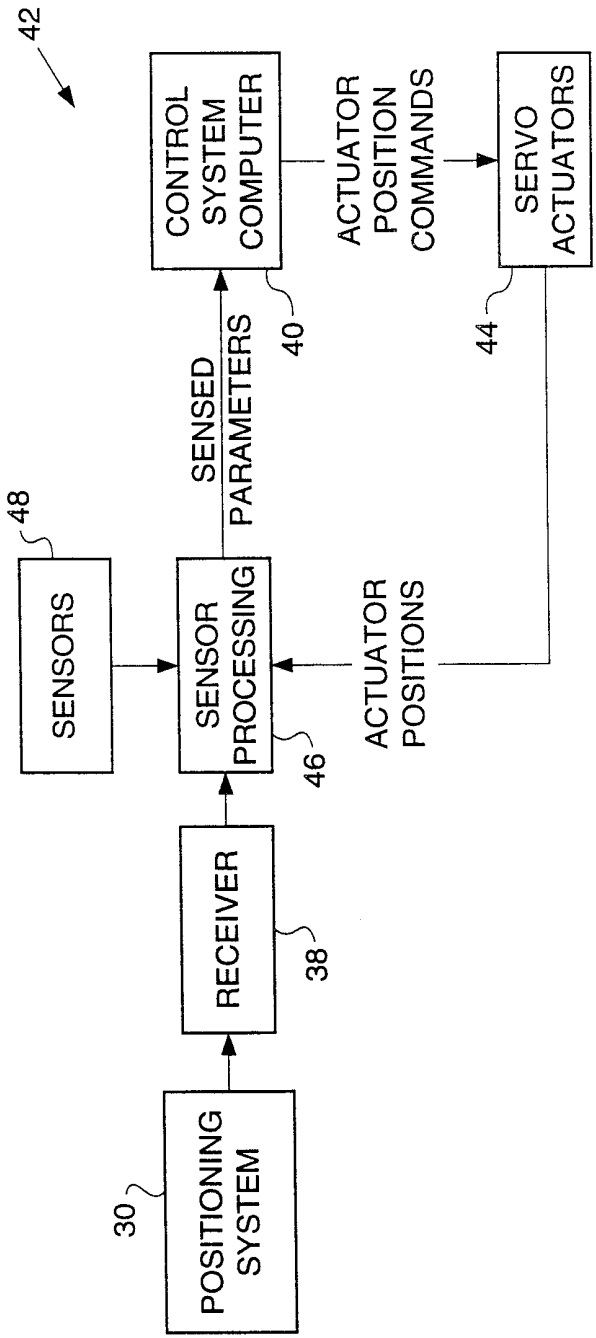
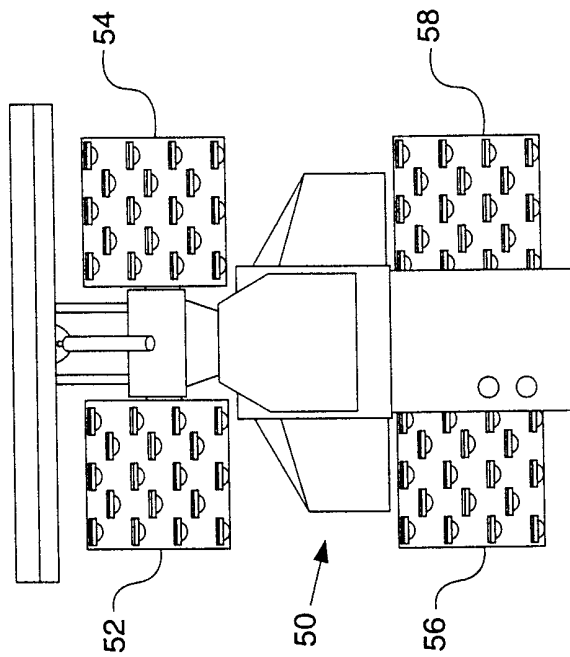
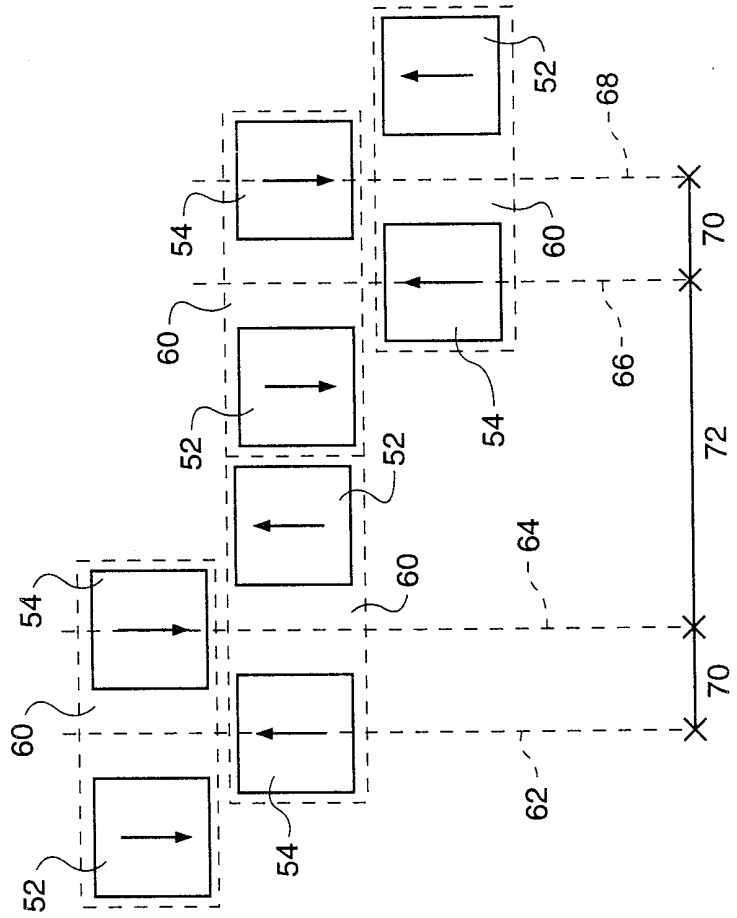
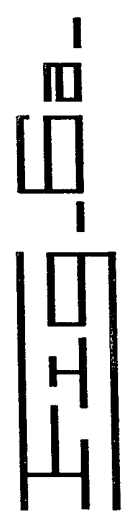
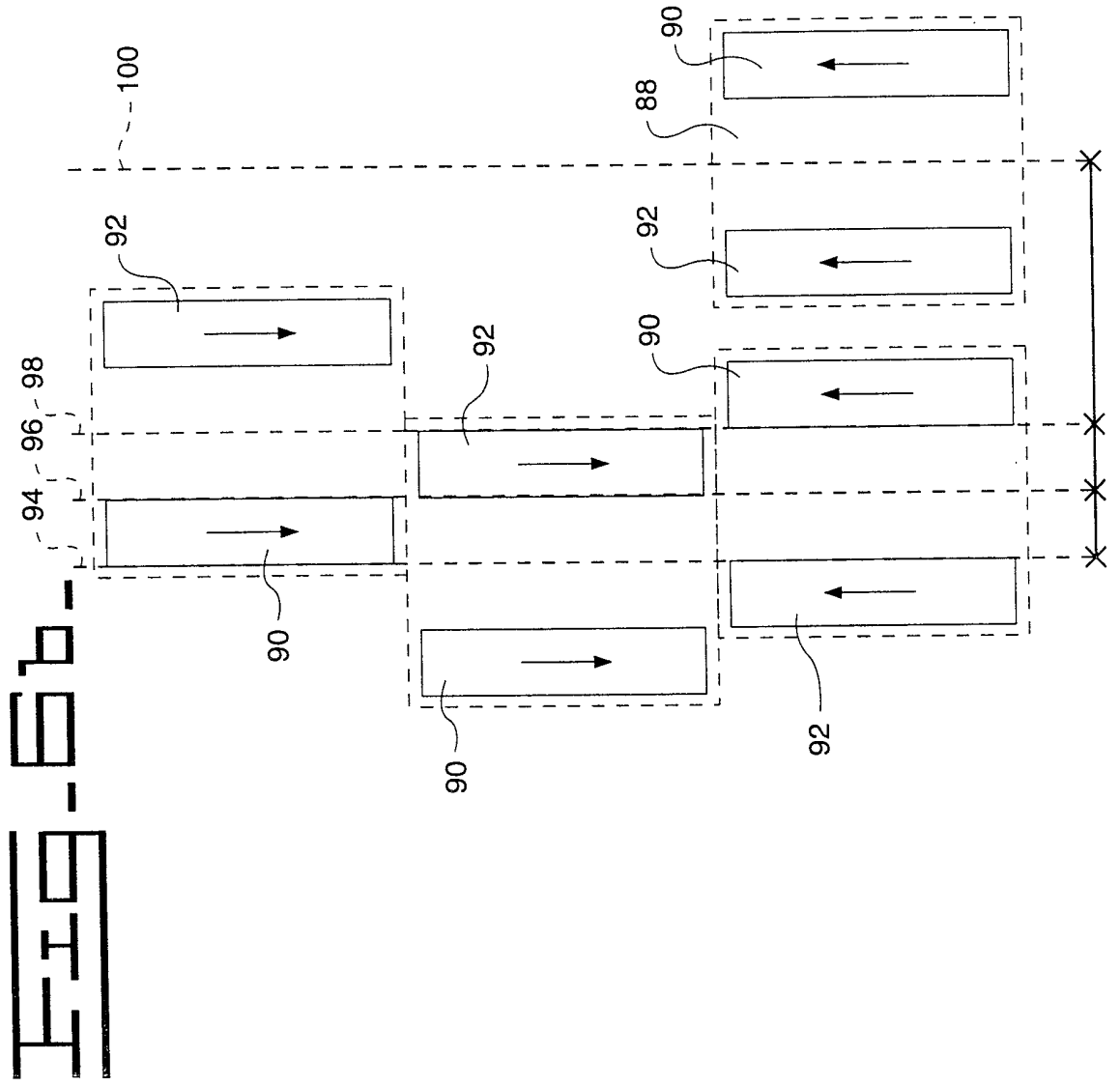

FIG. 4b.

FIG. 4a.





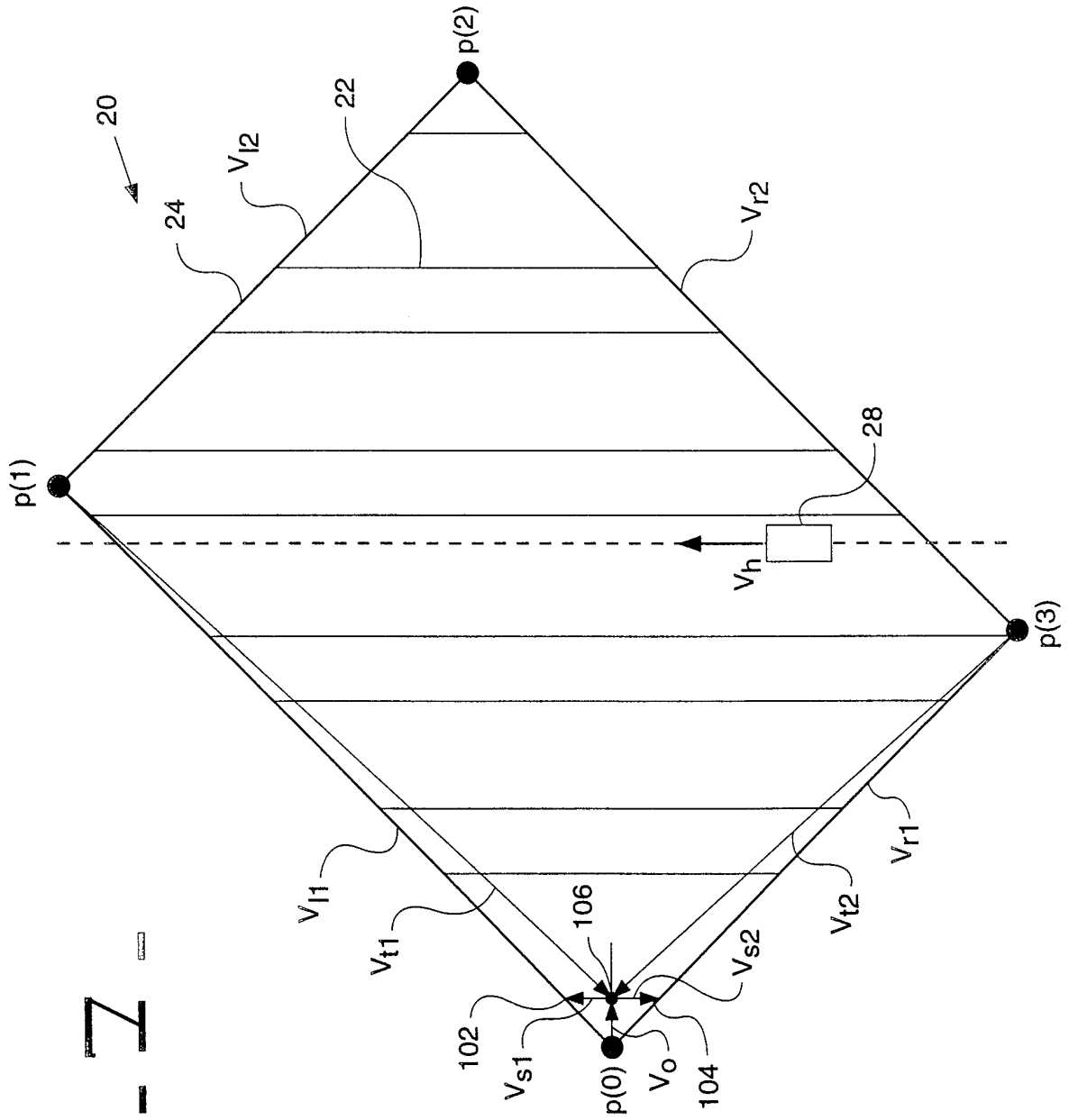
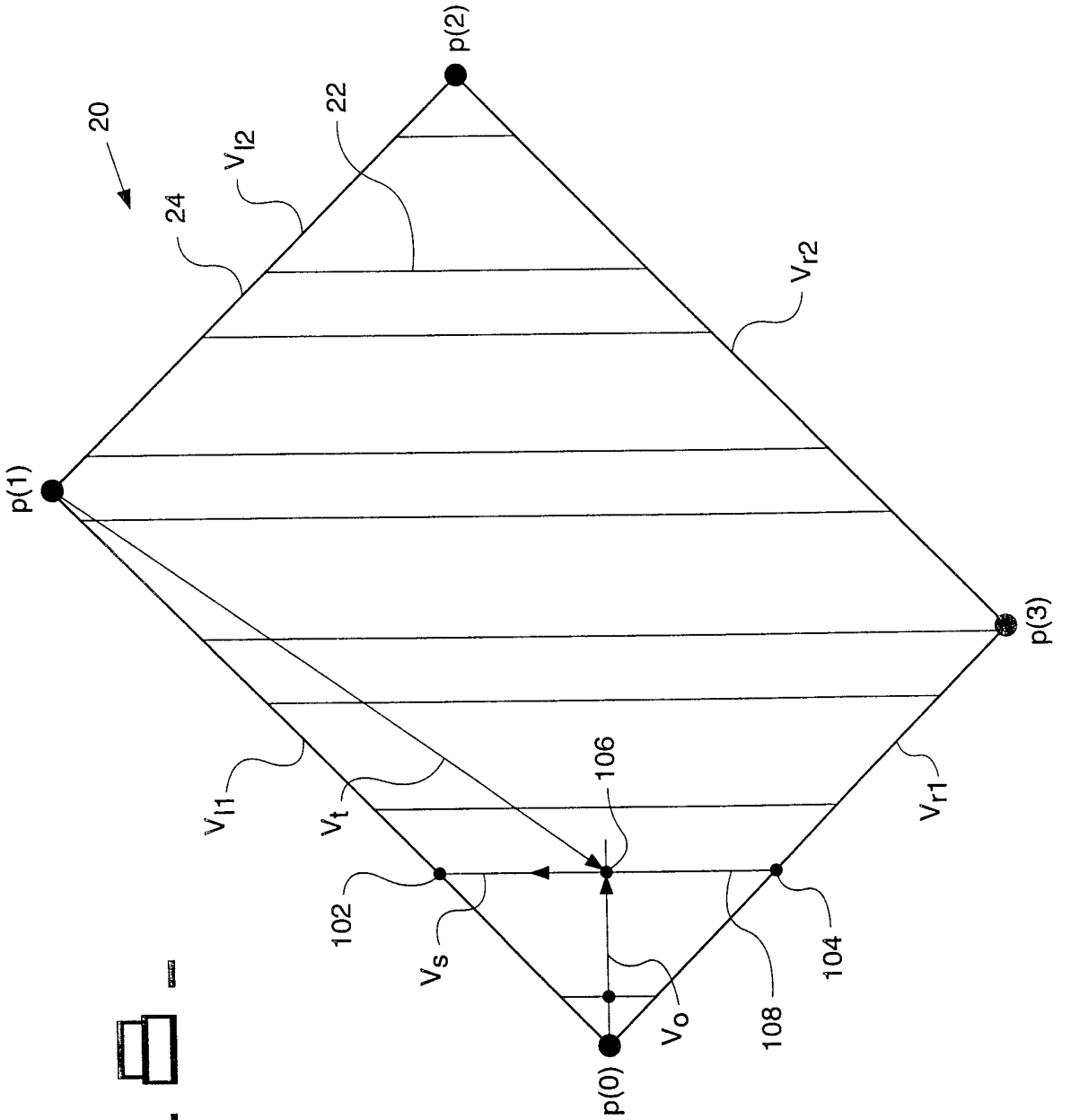

FIG. 7



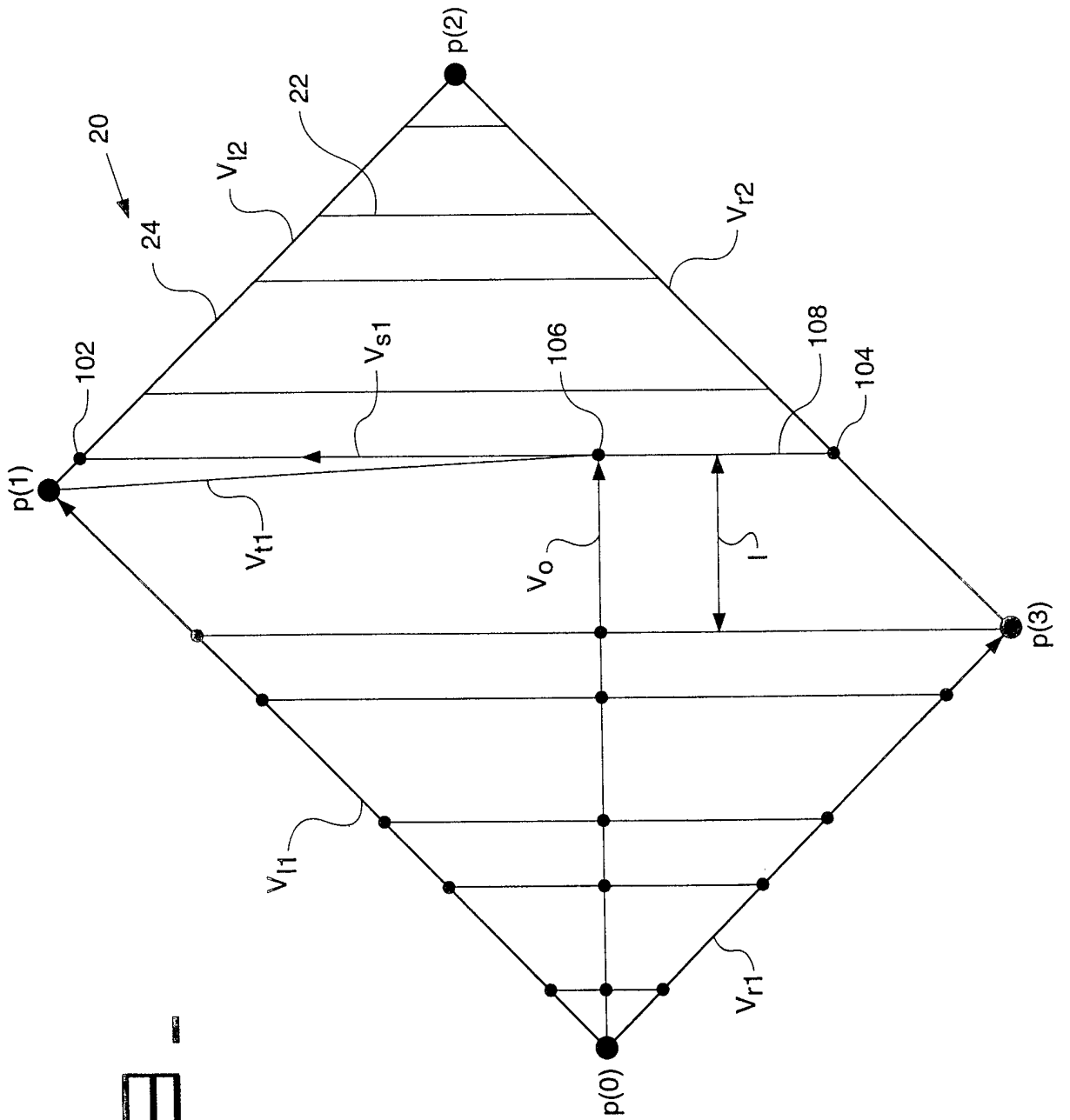

FIG. 8

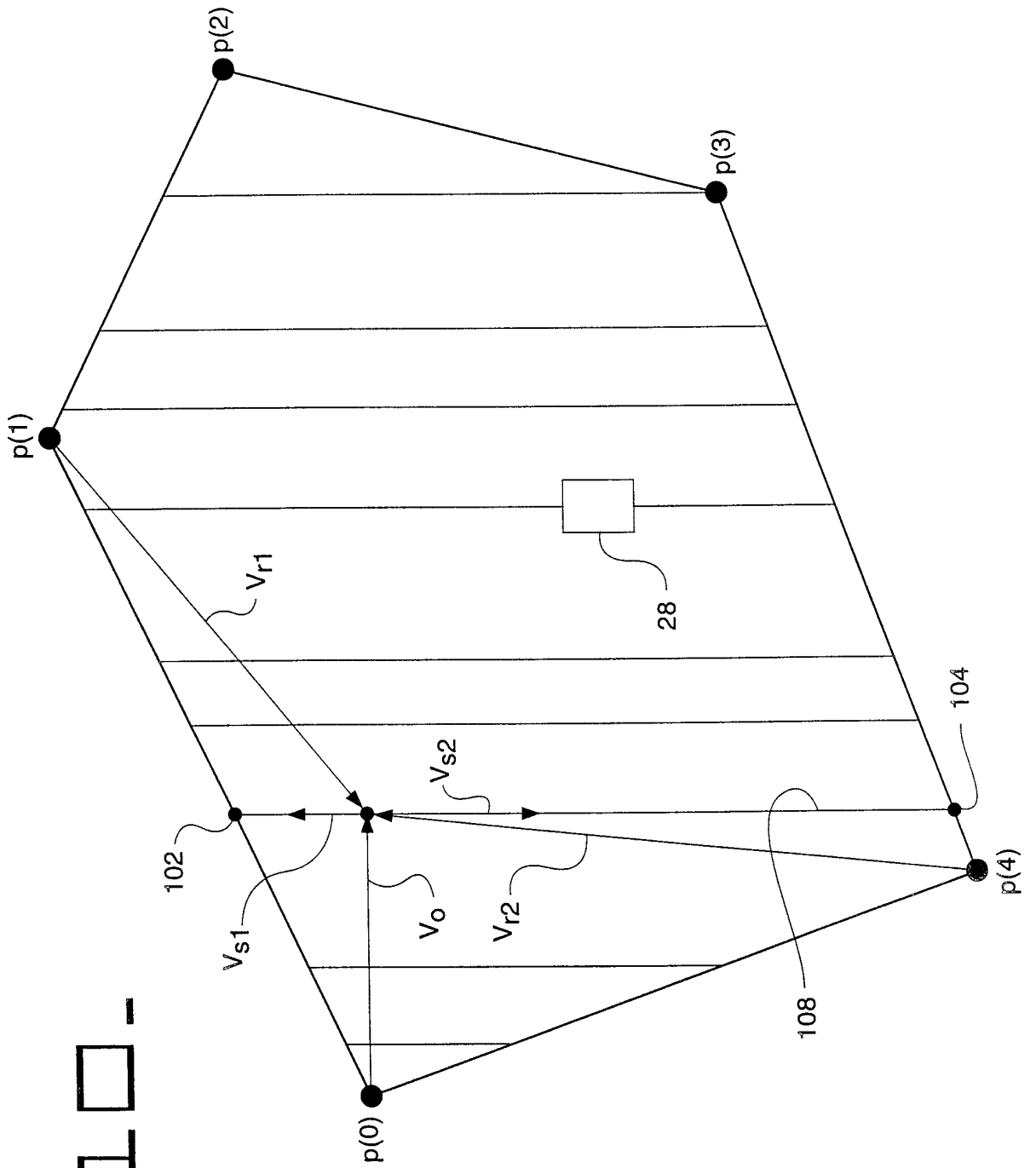

FIG. 10.

INTERNATIONAL SEARCH REPORT

International Application No

PCT/US 99/17325

A. CLASSIFICATION OF SUBJECT MATTER
 IPC 7 G05D1/02 E01C19/00 E02F3/84

According to International Patent Classification (IPC) or to both national classification and IPC

B. FIELDS SEARCHED

Minimum documentation searched (classification system followed by classification symbols)

IPC 7 G05D E01C E02F A01B A01D G01S

Documentation searched other than minimum documentation to the extent that such documents are included in the fields searched

Electronic data base consulted during the international search (name of data base and, where practical, search terms used)

C. DOCUMENTS CONSIDERED TO BE RELEVANT

Category *	Citation of document, with indication, where appropriate, of the relevant passages	Relevant to claim No.
X	EP 0 821 296 A (CLAAS KGAA) 28 January 1998 (1998-01-28) abstract page 2, line 25-44 page 2, line 52 -page 3, line 4 page 3, line 48 -page 4, line 1 page 4, line 22 -page 5, line 15 page 5, line 47-55 page 6, line 7-18; claims 1,3,6,20,21,23,24,29-31,39-46,54; figures 1,2A,2B,6 <div style="text-align: center;"> --- -/-- </div>	1,4,7,10

Further documents are listed in the continuation of box C.

Patent family members are listed in annex.

* Special categories of cited documents:

- "A" document defining the general state of the art which is not considered to be of particular relevance
- "E" earlier document but published on or after the international filing date
- "L" document which may throw doubts on priority claim(s) or which is cited to establish the publication date of another citation or other special reason (as specified)
- "O" document referring to an oral disclosure, use, exhibition or other means
- "P" document published prior to the international filing date but later than the priority date claimed

- "T" later document published after the international filing date or priority date and not in conflict with the application but cited to understand the principle or theory underlying the invention
- "X" document of particular relevance; the claimed invention cannot be considered novel or cannot be considered to involve an inventive step when the document is taken alone
- "Y" document of particular relevance; the claimed invention cannot be considered to involve an inventive step when the document is combined with one or more other such documents, such combination being obvious to a person skilled in the art.
- "&" document member of the same patent family

Date of the actual completion of the international search

7 January 2000

Date of mailing of the international search report

14/01/2000

Name and mailing address of the ISA

European Patent Office, P.B. 5818 Patentlaan 2
 NL - 2280 HV Rijswijk
 Tel. (+31-70) 340-2040, Tx. 31 651 epo nl,
 Fax: (+31-70) 340-3016

Authorized officer

Beitner, M

INTERNATIONAL SEARCH REPORT

International Application No
PCT/US 99/17325

C.(Continuation) DOCUMENTS CONSIDERED TO BE RELEVANT		
Category	Citation of document, with indication, where appropriate, of the relevant passages	Relevant to claim No.
A	<p>WO 98 19514 A (MAASLAND N.V.) 14 May 1998 (1998-05-14) abstract page 1, line 25 -page 2, line 6 page 3, line 7-15 page 4, line 2 -page 5, line 28; claims 1,6,7,15,16; figures 1,2</p> <p>---</p>	1,4,7,10
A	<p>US 5 187 663 A (KAMIMURA ET AL.) 16 February 1993 (1993-02-16) abstract column 4, line 40 -column 5, line 22 column 6, line 16 -column 7, line 21 column 10, line 16 -column 12, line 12; figures 3-7,10</p> <p>---</p>	1,4,7,10
A	<p>US 4 600 999 A (ITO ET AL.) 15 July 1986 (1986-07-15) abstract column 3, line 11 -column 4, line 15; figures 4,5</p> <p>---</p>	1,4,7,10
A	<p>PATENT ABSTRACTS OF JAPAN vol. 1998, no. 8, 30 June 1998 (1998-06-30) & JP 10 066405 A (SEIBUTSUKEI TOKUTEI SANGYO GIJUTSU KENKYU SUISHIN KIKO), 10 March 1998 (1998-03-10) abstract</p> <p>---</p>	1
A	<p>PATENT ABSTRACTS OF JAPAN vol. 1998, no. 8, 30 June 1998 (1998-06-30) & JP 10 066406 A (SEIBUTSUKEI TOKUTEI SANGYO GIJUTSU KENKYU SUISHIN KIKO), 10 March 1998 (1998-03-10) abstract</p> <p>-----</p>	1

INTERNATIONAL SEARCH REPORT

Information on patent family members

International Application No

PCT/US 99/17325

Patent document cited in search report	Publication date	Patent family member(s)	Publication date
EP 821296 A	28-01-1998	DE 19629618 A	29-01-1998
WO 9819514 A	14-05-1998	NL 1004450 C EP 0888043 A	08-05-1998 07-01-1999
US 5187663 A	16-02-1993	JP 3138708 A	13-06-1991
US 4600999 A	15-07-1986	JP 59011409 A AU 547146 B AU 1634583 A FR 2530114 A GB 2124798 A, B	21-01-1984 10-10-1985 19-01-1984 20-01-1984 22-02-1984
JP 10066405 A	10-03-1998	NONE	
JP 10066406 A	10-03-1998	NONE	