

(19) World Intellectual Property Organization
International Bureau



(43) International Publication Date
13 April 2006 (13.04.2006)

PCT

(10) International Publication Number
WO 2006/039296 A2

(51) International Patent Classification:
A61B 17/08 (2006.01)

(21) International Application Number:
PCT/US2005/034685

(22) International Filing Date:
26 September 2005 (26.09.2005)

(25) Filing Language: English

(26) Publication Language: English

(30) Priority Data:
10/954,665 29 September 2004 (29.09.2004) US
11/036,946 14 January 2005 (14.01.2005) US

(74) Agents: HESLIN, James, M. et al.; TOWNSEND AND TOWNSEND AND CREW LLP, Two Embarcadero Center, 8th Floor, San Francisco, California 94111-3834 (US).

(81) Designated States (unless otherwise indicated, for every kind of national protection available): AE, AG, AL, AM, AT, AU, AZ, BA, BB, BG, BR, BW, BY, BZ, CA, CH, CN, CO, CR, CU, CZ, DE, DK, DM, DZ, EC, EE, EG, ES, FI, GB, GD, GE, GH, GM, HR, HU, ID, IL, IN, IS, JP, KE, KG, KM, KP, KR, KZ, LC, LK, LR, LS, LT, LU, LV, LY, MA, MD, MG, MK, MN, MW, MX, MZ, NA, NG, NI, NO, NZ, OM, PG, PH, PL, PT, RO, RU, SC, SD, SE, SG, SK, SL, SM, SY, TJ, TM, TN, TR, TT, TZ, UA, UG, US, UZ, VC, VN, YU, ZA, ZM, ZW.

(84) Designated States (unless otherwise indicated, for every kind of regional protection available): ARIPO (BW, GH, GM, KE, LS, MW, MZ, NA, SD, SL, SZ, TZ, UG, ZM, ZW), Eurasian (AM, AZ, BY, KG, KZ, MD, RU, TJ, TM), European (AT, BE, BG, CH, CY, CZ, DE, DK, EE, ES, FI, FR, GB, GR, HU, IE, IS, IT, LT, LU, LV, MC, NL, PL, PT, RO, SE, SI, SK, TR), OAPI (BF, BJ, CF, CG, CI, CM, GA, GN, GQ, GW, ML, MR, NE, SN, TD, TG).

(71) Applicant (for all designated States except US): USGI MEDICAL INC. [US/US]; 1140 Calle Cordillera, San Clemente, California 92673 (US).

(71) Applicant and

(72) Inventor: SAADAT, Vahid [US/US]; 12679 Kane Drive, Saratoga, California 95070 (US).

(72) Inventors; and

(75) Inventors/Applicants (for US only): WESTRA, Hendrik, S. [US/US]; 1407 Buena Vista, #7, San Clemente, California 92672 (US). LAM, Cang, C. [US/US]; 74 Stanford Court, Irvine, California 92612 (US). EWERS, Richard, C. [US/US]; 1437 West Malvern, Fullerton, California 92833 (US).

Declaration under Rule 4.17:

— as to applicant's entitlement to apply for and be granted a patent (Rule 4.17(ii))

Published:

— without international search report and to be republished upon receipt of that report

For two-letter codes and other abbreviations, refer to the "Guidance Notes on Codes and Abbreviations" appearing at the beginning of each regular issue of the PCT Gazette.

(54) Title: METHODS AND APPARATUS FOR GRASPING AND CINCHING TISSUE ANCHORS

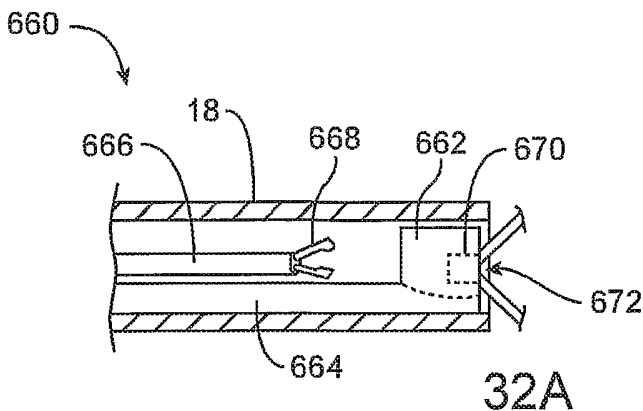

degree of cinching or locking may be provided during cinching.

(57) Abstract: Methods and apparatus for controlled grasping and cinching or locking of a tissue anchor are provided. In one variation, a tube is provided having a lumen and a resilient member that obstructs the lumen. A grasper may be advanced coaxially through the lumen, such that it reversibly displaces the resilient member and extends beyond the lumen's outlet to engage an element of the tissue anchor. The grasper then may be retracted within the tube, such that the resilient member again obstructs the lumen of the tube. Continued retraction of the grasper may act to cinch the anchor, for example, via interaction between the anchor and the obstructing resilient member. During cinching, a cinching mechanism of the anchor optionally may be positioned at least partially within the tube to enhance lateral stability. Furthermore, feedback indicative of a

WO 2006/039296 A2

METHODS AND APPARATUS FOR GRASPING AND CINCHING TISSUE ANCHORS

BACKGROUND OF THE INVENTION

5 [0001] Field of the Invention. The present invention relates to apparatus and methods for positioning and securing anchors within tissue, such as folds of tissue within a body. More particularly, the present invention relates to apparatus and methods for grasping and cinching tissue anchors.

[0002] Morbid obesity is a serious medical condition pervasive in the United States and
10 other countries. Its complications include hypertension, diabetes, coronary artery disease, stroke, congestive heart failure, multiple orthopedic problems and pulmonary insufficiency with markedly decreased life expectancy.

[0003] A number of surgical techniques have been developed to treat morbid obesity, e.g.,
bypassing an absorptive surface of the small intestine, or reducing the stomach size.
15 However, many conventional surgical procedures may present numerous life-threatening post-operative complications, and may cause atypical diarrhea, electrolytic imbalance, unpredictable weight loss and reflux of nutritious chyme proximal to the site of the anastomosis.

[0004] Furthermore, the sutures or staples that are often used in these surgical procedures
20 typically require extensive training by the clinician to achieve competent use, and may concentrate significant force over a small surface area of the tissue, thereby potentially causing the suture or staple to tear through the tissue. Many of the surgical procedures require regions of tissue within the body to be approximated towards one another and reliably secured. The gastrointestinal lumen includes four tissue layers, wherein the mucosa layer is
25 the inner-most tissue layer followed by connective tissue, the muscularis layer and the serosa layer.

[0005] One problem with conventional gastrointestinal reduction systems is that the
anchors (or staples) should engage at least the muscularis tissue layer in order to provide a
proper foundation. In other words, the mucosa and connective tissue layers typically are not
30 strong enough to sustain the tensile loads imposed by normal movement of the stomach wall

during ingestion and processing of food. In particular, these layers tend to stretch elastically rather than firmly hold the anchors (or staples) in position, and accordingly, the more rigid muscularis and/or serosa layer should ideally be engaged. This problem of capturing the muscularis or serosa layers becomes particularly acute where it is desired to place an anchor or other apparatus transesophageally rather than intraoperatively, since care must be taken in piercing the tough stomach wall not to inadvertently puncture adjacent tissue or organs.

[0006] One conventional method for securing anchors within a body lumen to the tissue is to utilize sewing devices to suture the stomach wall into folds. This procedure typically involves advancing a sewing instrument through the working channel of an endoscope and into the stomach and against the stomach wall tissue. The contacted tissue is then typically drawn into the sewing instrument where one or more sutures or tags are implanted to hold the suctioned tissue in a folded condition known as a plication. Another method involves manually creating sutures for securing the plication.

[0007] One of the problems associated with these types of procedures is the time and number of intubations needed to perform the various procedures endoscopically. Another problem is the time required to complete a plication from the surrounding tissue with the body lumen. In the period of time that a patient is anaesthetized, procedures such as for the treatment of morbid obesity or for GERD must be performed to completion. Accordingly, the placement and securement of the tissue plication should ideally be relatively quick and performed with a minimal level of confidence.

[0008] Another problem with conventional methods involves ensuring that the staple, knotted suture, or clip is secured tightly against the tissue and that the newly created plication will not relax under any slack which may be created by slipping staples, knots, or clips. Other conventional tissue securement devices such as suture anchors, twist ties, crimps, etc. are also often used to prevent sutures from slipping through tissue. However, many of these types of devices are typically large and unsuitable for low-profile delivery through the body, e.g., transesophageally.

[0009] Moreover, when grasping or clamping onto or upon the layers of tissue with conventional anchors, sutures, staples, clips, etc., many of these devices are configured to be placed only after the tissue has been plicated and not during the actual plication procedure.

BRIEF SUMMARY OF THE INVENTION

[0010] In securing plications, which may be created within a body lumen of a patient, various methods and devices may be implemented. Generally, any number of conventional methods may be utilized for initially creating the plication. One method in particular may involve creating a plication through which a tissue anchor may be disposed within or through. A distal tip of a tissue plication apparatus may engage or grasp the tissue and move the engaged tissue to a proximal position relative to the tip of the device, thereby providing a substantially uniform plication of predetermined size. Examples of tools and methods that are particularly suited for delivering the anchoring and securement devices may be seen in further detail in co-pending U.S. Pat. App. Serial No. 10/735,030 filed December 12, 2003, which is incorporated herein by reference in its entirety.

[0011] In securing these plications, various tissue anchors may be utilized for securing the plications in their configured folds. For example, a plication (or plications) may be secured via a length or lengths of suture extending through the plication and between a distally-positioned tissue anchor located on a distal side of the plication and a proximally-positioned tissue anchor located on a proximal side of the plication. Examples of anchors which may be utilized are disclosed in co-pending U.S. Pat. App. Serial No. 10/612,170, filed July 1, 2003, which is incorporated herein by reference in its entirety.

[0012] Generally, in securing a tissue plication, a proximally and/or distally located tissue anchor is preferably configured to slide along the connecting suture in a uni-directional manner. For instance, if the proximal anchor is to be slid along the suture, it is preferably configured to translate over the suture such that the tissue plication is cinched between the anchors. In this example, the proximal anchor is preferably configured to utilize a locking mechanism, which allows for the free uni-directional translation of the suture therethrough while enabling the anchor to be locked onto the suture if the anchor is pulled, pushed, or otherwise urged in the opposite direction along the suture. This uni-directional anchor locking mechanism facilitates the cinching of the tissue plication between the anchors and it may be utilized in one or several of the anchors in cinching a tissue fold.

[0013] Moreover, the types of anchors utilized for the securement of tissue plications are not intended to be limiting. For instance, many of the anchor locking or cinching mechanisms may be utilized with, e.g., "T"-type anchors as well as with reconfigurable "basket"-type anchors, which generally comprise a number of configurable struts or legs

extending between at least two collars or support members. Other variations of these or other types of anchors are also contemplated for use in an anchor locking or cinching assembly.

[0014] For instance, linear anchors, i.e., elongate anchors that are configured to fold or become compressed into a bowed or expanded configuration, may also be utilized. Such anchors may be configured in a variety of different configurations, such as flattened ribbon or wire, having one or more openings along its length through which a length of suture may be routed. Generally, a linear-type anchor for placement against a tissue surface may comprise an elongate member having a proximal end, a distal end, and a length therebetween defining a plurality of holes, a length of suture for passage through at least one of the holes, and wherein the elongate member is adapted to be reconfigured from a straightened configuration to an expanded anchoring configuration when the elongate member is compressed longitudinally. In utilizing such a linear-type anchor, one method of positioning the anchor against the tissue surface may generally comprise positioning an elongate member in a straightened configuration against the tissue surface, the elongate member having a proximal end, a distal end, and a length therebetween, and compressing the elongate member longitudinally such that the elongate member reconfigures to an expanded anchoring configuration against the tissue surface.

[0015] Furthermore, a single type of anchor may be used exclusively in an anchor locking or cinching assembly; alternatively, a combination of different anchor types each utilizing different anchor locking or cinching mechanisms may be used in a single assembly. Furthermore, the different types of cinching or locking mechanisms are not intended to be limited to any of the particular variations shown and described below but may be utilized in any combinations or varying types of anchors as practicable.

[0016] The suture itself may be modified or altered to integrate features or protrusions along its length or a specified portion of its length. Such features may be defined uniformly at regular intervals along the length of suture or intermittently, depending upon the desired locking or cinching effects. Furthermore, the suture may be made from metals such as Nitinol, stainless steels, Titanium, etc., provided that they are formed suitably thin and flexible. Using metallic sutures with the anchoring mechanisms may decrease any possibilities of suture failure and it may also provide a suture better able to withstand the acidic and basic environment of the gastrointestinal system. Also, it may enhance imaging of the suture and anchor assembly if examined under imaging systems. Sutures incorporating

the use of features or protrusions along its length as well as sutures fabricated from metallic materials or any other conventional suture type may be utilized with any of the locking or cinching mechanisms described below in various combinations, if so desired.

5 [0017] One variation for utilizing a locking mechanism, which allows for free uni-directional translation of the suture through the anchor, may include blocks or members, which are adapted to slide within or upon an anchor to lock the suture. These blocks or members may include tapered edges, which act to cleat the suture depending upon the direction the anchor is translated relative to the suture. Moreover, these blocks may be biased or urged to restrict the movement of the suture using a variety of biasing elements, such as
10 springs, etc. In addition to blocks, one or several locking tabs, which are levered to allow uni-directional travel of the suture through an anchor, may also be utilized.

[0018] Aside from the use of mechanical locking features integrated within or with the anchor bodies, locking mechanisms may also utilize a variety of knotting techniques. Conventional knots, which are typically tied by the practitioner either within the body or
15 outside the body and advanced over the suture length, may be utilized for locking the anchor in place relative to the tissue fold and opposing anchor; however, self-locking knots which enable the uni-directional travel of an anchor body relative to the suture and tissue are desirable. Accordingly, many different types of self-locking knots may be advanced with the anchor over the suture such that translation along a distal direction is possible, yet reverse
20 translation of the anchor is inhibited.

[0019] Various anchor cinching or locking mechanisms utilizing friction as a primary source for locking may also be implemented. For instance, locking pins may be urged or pushed into a frictional interference fit with portions or areas of the suture against the anchor or portions of the anchor. The use of such pins may effectively wedge the suture and thereby
25 prevent further movement of the anchor along the suture length. In addition to pins, locking collars or collets may also be used to cinch or lock the suture.

[0020] In addition to friction-based locking and cinching mechanisms utilizable in tissue anchors, other mechanisms that create tortuous paths for the suture within or through the anchors may also be utilized for creating uni-directional locking. One cinching variation may
30 utilize a pulley or pin contained within the anchor over which a portion of the suture may travel. The looped suture may then be routed proximally and secured with a slip knot. As

tension is applied to the suture, the slip knot may prevent the further movement of the anchor relative to the suture.

[0021] Another variation on utilizing tortuous paths may comprise collars, which are independent from or integrally formed with the anchors. Such cinching collars may generally be formed into tubular structures having obstructions formed within the collar lumen where the obstructions are formed from portions of the cinching collar itself. These obstructions may be adapted to form upon releasing of a constraining force when the anchor is to be locked into position. These obstructions may be used to form a tortuous path through which the suture may be routed to lock the suture within.

[0022] Moreover, locking collars that form tortuous paths may be adapted to reconfigure itself from a constrained delivery configuration to a deployed locking configuration when the anchor is to be cinched or locked into position relative to the tissue and suture. The locking collars may be configured to take various configurations, such as a proximally extending "S"-type, or other types, configuration.

[0023] Other cinching and locking mechanisms, which utilize mechanical clamping or crimping to achieve locking of the suture within or through the anchors, may also be used to facilitate uni-directional locking. For instance, a simple mechanical crimp may be fastened upon the suture proximally of the anchor to prevent the reverse motion of the anchor. The crimp may be a simple tubular member or it may be integrally formed onto a proximal portion of the anchor body itself.

[0024] Aside from the crimping mechanisms described above, additional measures may be optionally implemented to facilitate the cinching or locking of an anchor. Other measures may also be taken to inhibit any damage from occurring to the suture routed through an anchor. For instance, to ensure that the integrity of the suture is maintained in the presence of metallic basket anchors and to ensure that the suture is not subjected to any nicks or cuts, the portion of the suture passing through basket anchor may be encased in a protective sleeve made, e.g., from polypropylene, PTFE, etc.

[0025] Another measure, which optionally may be implemented, is cinching or locking mechanisms that take advantage of any cold-flow effects of an engaged portion of suture by the tissue anchor. For instance, if a portion of the suture is wedged against the collar of an anchor or cinching member to lock the anchor, the portion of the collar may have multiple

holes defined over its surface to allow for portions of the engaged suture to cold-flow at least partially into or through the holes to enhance the locking effects.

[0026] Alternatively, the collar may be formed with an electrically conductive inner sleeve surrounded by an outer sleeve capable of flowing at least partially when heated. The inner sleeve may have a number of holes defined over its surface such that when the outer sleeve is heated, either by inductive heating or any other method, the outer sleeve material may flow through the holes and into contact with the suture passing therethrough. This contact may also enhance the locking effects of the collar.

[0027] In addition to the anchors and anchor assemblies described herein, as well as the various cinching and locking features and mechanisms for use therewith, methods and apparatus for grasping a suture and cinching and/or locking a tissue anchor (e.g., actuating a cinching or locking feature or mechanism of the anchor) are described. Force feedback apparatus and methods for use with the grasping and cinching methods and apparatus are also provided, e.g., for monitoring and/or controlling cinching forces applied to the tissue anchors or anchor assemblies.

[0028] In one variation, a tube is provided having a lumen with a distal outlet, and a resilient member that obstructs at least a portion of the lumen. A grasper may be advanced coaxially through the lumen of the tube, such that it reversibly displaces the resilient member and extends beyond the tube's distal outlet. The grasper may engage suture or another portion of a tissue anchor. The grasper then may be withdrawn within the tube with the engaged suture, such that the resilient member at least partially obstructs the lumen of the tube. Continued retraction of the grasper relative to the tube and anchor may act to cinch the anchor via interaction between a cinching/locking mechanism of the anchor and the resilient member. The cinching/locking mechanism optionally may be positioned at least partially within the tube during cinching to laterally stabilize the mechanism while cinching the anchor.

[0029] In an alternative variation, a snare device is provided for grasping a suture and cinching/locking a tissue anchor. The snare device may comprise a resilient wire loop and a coating element of the snare device or of the tissue anchor. As with the grasper device, the snare device is configured for advancement through the lumen of a tube.

[0030] In one variation, the coating element comprises a resilient latch of the snare device. The snare may resiliently expand upon advancement past a distal outlet of the tube, such that

the latch and loop form an opened 'mouth' in which the suture of a tissue anchor may be captured. Upon placement of suture in the open space between the latch and loop, the snare device may be retracted relative to the tube, such that the tube urges the latch down into the loop, thereby closing the 'mouth' of the snare device and reversibly capturing the suture
5 therein. Continued retraction of the snare device relative to the tissue anchor may cinch and/or lock the anchor in a deployed configuration. The suture then may be released by re-advancing the snare device relative to the tube to 'unlatch' the snare device.

[0031] In another variation, the coating element may comprise a protrusion of the tissue anchor, such as a knot or bead disposed on a suture of the tissue anchor. The protrusion may
10 be passed through the resilient loop of the snare device, which then may be retracted relative to the tube. The snare device is reversibly collapsed within the lumen of the tube, which reversibly captures the protrusion. Continued retraction of the snare device relative to the tube and tissue anchor may cinch and/or lock the anchor in the deployed configuration. The suture then may be released by re-advancing the snare device relative to the tube to resiliently
15 expand the wire loop and allow for passage of the protrusion therethrough.

[0032] Additional variations of the methods and apparatus are described.

BRIEF DESCRIPTION OF THE DRAWINGS

[0033] Fig. 1A shows a side view of one variation of a tissue plication apparatus that may be used to create tissue plications and to deliver cinching or locking anchors into the tissue.

20 [0034] Figs. 1B and 1C show detail side and perspective views, respectively, of the tissue manipulation assembly of the device of Fig. 1A.

[0035] Figs. 2A to 2D show an example of a tissue plication procedure for the delivery and placement of tissue anchors.

25 [0036] Figs. 3A to 3G show detail cross-sectional views of an anchor delivery assembly in proximity to a tissue plication and an example of delivering the tissue anchors on distal and proximal sides of the plication.

[0037] Figs. 4A and 4B show side and end views, respectively, of one anchor variation which is illustrated in the form of a T-type anchor utilizing locking blocks or members for cinching and locking the suture.

[0038] Fig. 5 shows a side view of another cinching anchor variation utilizing locking blocks or members.

[0039] Fig. 6 shows yet another side view of a cinching anchor variation utilizing locking blocks or members.

5 [0040] Fig. 7 shows a perspective view of another locking anchor variation in which the anchor body defines an opening having a tapered or grooved portion.

[0041] Figs. 8A and 8B show cross-sectional side and top views, respectively, of another locking anchor variation utilizing a through-hole passage or opening and uni-directional levers or pivots through which the suture may pass.

10 [0042] Fig. 8C shows a cross-sectional side view of an anchor body in combination with a modified suture having integrated features or protrusions defined along its length.

[0043] Figs. 9A and 9B show cross-sectional views of locking anchor variations having biased locking members in combination with a knotted suture.

15 [0044] Fig. 9C shows another modification of the suture which may be coated with a metallic covering or slid within a sleeve.

[0045] Fig. 10 shows a cross-sectional side view of an anchor assembly which utilizes a choke-type loop for cinching the anchors uni-directionally towards one another.

[0046] Fig. 11A shows a perspective view of another anchor assembly utilizing a slip knot at the proximal anchor.

20 [0047] Figs. 11B and 11C show top and cross-sectional side views, respectively, of an anchor which may optionally define grooves or channels extending at least partially therein to facilitate the cinching or wedging of the sutures within the grooves.

[0048] Figs. 12A to 12G show examples of anchor assemblies utilizing various slip knots and looped sections which provide uni-directional travel for the anchors over the sutures.

25 [0049] Fig. 13A shows a cross-sectional side view of an anchor delivery system delivering a basket-type anchor into or through a tissue plication.

[0050] Fig. 13B shows a cross-sectional side view of multiple tissue plications which may be cinched towards one another and basket anchors as being deliverable through one or both tissue plications.

[0051] Figs. 14A and 14B show cross-sectional side views of an anchor cinching assembly utilizing a cinching collar or collet which may be wedged into an anchor collar for clamping upon the suture.

[0052] Figs. 15A and 15C show cross-sectional side views of another anchor cinching assembly utilizing a pin for wedging against a portion of the suture.

[0053] Figs. 15B and 15D show end views of the assembly of Figs. 15A and 15C, respectively.

[0054] Fig. 15E shows a perspective view of another cinching variation utilizing one or more tapered pins or blocks slidably disposed within a tapered channel defined in a proximal collar of the anchor.

[0055] Fig. 15F shows a perspective view of the tapered pins from Fig. 15E.

[0056] Figs. 15G and 15H show cross-sectional side views of an alternative cinching assembly having a retractable pin in an engaged and disengaged configuration, respectively.

[0057] Figs. 16A and 16B show cross-sectional side views of another variation of a cinching assembly having a rotatable cinching collar.

[0058] Figs. 17A and 17B show cross-sectional side views of another cinching assembly having a retaining tube for providing a counterforce to stabilize the assembly during cinching or locking.

[0059] Figs. 18A and 18B show cross-sectional side views of another cinching assembly having one or several biasing members or cinching tabs.

[0060] Figs. 18C and 18D show end and perspective views, respectively, of a suture release member which may be used with the assembly of Figs. 18A and 18B.

[0061] Figs. 19A and 19B show cross-sectional side views of another variation of a cinching assembly utilizing a deformable cinching member positioned within the anchor and distally of the anchor collar.

[0062] Fig. 20A shows a cross-sectional side view of another cinching assembly utilizing a pivoting cinching member configured to lock against the suture.

[0063] Figs. 20B, 20C, and 20D show end and cross-sectional side views, respectively, of the pivoting member positioned within the anchor collar.

[0064] Figs. 20E and 20F show cross-sectional side and perspective views, respectively, of another cinching assembly having a pivoting cinching member positioned proximally of the anchor collar.

5 [0065] Figs. 21A and 21B show cross-sectional side views of another cinching assembly configured to cinch or lock the suture with a tapered collar.

[0066] Fig. 22A shows a cross-sectional side view of another cinching assembly utilizing a looped suture and a slip knot for cinching the anchor over the suture.

10 [0067] Figs. 22B and 22C show cross-sectional side and detail views, respectively, of another cinching assembly which may be utilized with a portion of suture wrapped or looped about a pin which enables uni-directional travel of the anchor relative to the suture

[0068] Figs. 22D and 22E show cross-sectional side and detail views, respectively, of another cinching assembly utilizing looped suture wedged within the anchor collar.

[0069] Fig. 23 shows a cross-sectional side view of a cinching assembly variation utilizing a number of pulleys to create the cinching effect.

15 [0070] Fig. 24A shows a cross-sectional side view of another cinching assembly variation in which a cinching sleeve may be used to create a tortuous path for the suture.

[0071] Figs. 24B and 24C show cross-sectional side views of another cinching assembly variation having a tubular structure, with and without retaining arms, respectively, positioned within the anchor collar through which the suture may pass uni-directionally.

20 [0072] Fig. 24D shows a perspective view of one variation of the tubular structure of Fig. 24C with retaining arms.

[0073] Figs. 25A and 25B show cross-sectional side views of another cinching assembly variation in which a cinching collar, which may be independent of the anchor or formed integrally with the anchor, respectively, may have a tortuous path formed within the collar.

25 [0074] Fig. 25C shows a perspective view of the collar of Fig. 25A in its unobstructed configuration with a constraining sleeve which may be positioned within the collar.

[0075] Figs. 26A and 26B show cross-sectional side views of another cinching assembly variation utilizing one or several pivoting levers which allow uni-directional travel of the suture therethrough.

[0076] Figs. 26C and 26D show alternative end views of the assembly of Fig. 26A in which the lever may be configured to prevent over cinching onto the suture.

[0077] Figs. 26E to 26G show cross-sectional side views of alternative cinching assemblies in which the levers may be variously configured to create the tortuous path.

5 [0078] Figs. 27A and 27B show side views of another cinching assembly variation in a delivery profile and a reconfigured profile, respectively, which utilizes a crimp which may be self-forming.

[0079] Figs. 28A and 28B show cross-sectional side views of another cinching assembly variation utilizing either two cinching collars or a single integral cinching collar, respectively.

10 [0080] Fig. 28C shows a cross-sectional side view of the cinching collar of Fig. 28A in one configuration for cinching the suture.

[0081] Figs. 28D and 28E show perspective views of the cinching collar of Fig. 28A in a delivery profile and a reconfigured profile.

15 [0082] Fig. 28F shows a cross-sectional side view of another variation for a cinching configuration of the cinching collar of Fig. 28B.

[0083] Figs. 28G and 28H show cross-sectional side views of another cinching assembly variation in a delivery profile and reconfigured profile, respectively, in which an elongate cinching member may reconfigure itself to create a tortuous path for the suture.

20 [0084] Figs. 29A and 29B show cross-sectional side views of another cinching assembly variation utilizing a mechanical crimp.

[0085] Figs. 30A and 30B show cross-sectional side views of another cinching assembly variation in which a mechanical crimp may be utilized on the proximal collar of the anchor body.

25 [0086] Fig. 31A shows a cross-sectional side view of a variation of a tool assembly which may be adapted to apply a mechanical crimping force upon a crimping collar.

[0087] Figs. 31B to 31D show side, end, and perspective views, respectively, of a variation on a crimping collar which may be utilized as a separate crimping sleeve or as part of the anchor collar.

[0088] Figs. 32A and 32B show cross-sectional side and perspective views, respectively, of an alternative crimping tool.

[0089] Figs. 33A and 33B show perspective and end views, respectively, of a representative basket anchor having a protective sleeve encasing the suture disposed within
5 the anchor.

[0090] Figs. 34A and 34B show cross-sectional side and perspective views, respectively, of a cinching collar defining a plurality of holes through the surface of the collar for enhancing the locking effects with the suture.

[0091] Fig. 35A shows a cross-sectional side view of a cinching assembly variation which may utilize inductive heating to partially melt a portion of an outer sleeve into contact with
10 the suture to enhance the anchor locking effects.

[0092] Figs. 35B and 35C show perspective assembly and exploded views, respectively, of an electrically conductive inner sleeve contained within the outer sleeve.

[0093] Figs. 35D and 35E show perspective views of alternative inner sleeves which may
15 be utilized with the assembly of Fig. 35A.

[0094] Figs. 36A and 36B show perspective views of variations of linear anchors generally comprised of elongate ribbon or flattened wire and defining one or more openings along their lengths.

[0095] Figs. 37A and 37B show the ribbon anchors of Figs. 36A and 36B, respectively,
20 with lengths of suture routed through the openings.

[0096] Fig. 38 shows another variation of a ribbon anchor having alternating portions of the ribbon material between the openings notched out or removed.

[0097] Fig. 39 shows another variation of a ribbon anchor defining undulations such that an "S"-type ribbon pattern is formed.

[0098] Fig. 40A shows the ribbon anchor of Fig. 36A with biasing springs positioned along
25 portions of the ribbon anchor with suture routed therethrough.

[0099] Fig. 40B shows another variation of the ribbon anchor of Fig. 40A having biased ribbon elements rather than springs.

[0100] Fig. 40C shows the ribbon anchor of Fig. 40A in a partially collapsed configuration.

[0101] Fig. 40D shows the ribbon anchor of Fig. 40B in a partially collapsed configuration.

[0102] Fig. 41 shows an alternative variation of the ribbon anchor comprised of a tubular member.

[0103] Fig. 42 shows a perspective view of another alternative variation of the ribbon anchor comprised of a tubular member having a partial cut-out along its length.

[0104] Fig. 43 shows a perspective view of yet another alternative variation of the ribbon anchor having multiple cut-outs along its length.

[0105] Fig. 44 shows a perspective view of yet another alternative having multiple individual lengths of elements encased (or at least partially encased) in a coating or covering.

10 [0106] Fig. 45 shows a perspective view of yet another alternative having one or more lengths of wire covered or coated.

[0107] Fig. 46 shows another variation in which a length of the ribbon anchor may have a non-uniform thickness.

15 [0108] Figs. 47A and 47B shows yet other variations in which a length of wire having eyelets or defining loops may be utilized to fold or flatten into an expanded pattern.

[0109] Fig. 48 shows another variation in which a wire or ribbon may be comprised of a shape memory alloy which is configured to form a tangled portion of the wire when unconstrained.

20 [0110] Figs. 49A and 49B show partial cross-sectional views of ribbon anchors in a flattened linear configuration becoming compressed into a collapsed and expanded configuration, respectively, against a fold of tissue.

[0111] Figs. 50A to 50C show top views of various bowed or expanded configurations of a ribbon anchor.

25 [0112] Figs. 51A to 51D show schematic side views of a variation of apparatus and a method for grasping and cinching a tissue anchor.

[0113] Figs. 52A to 52D show schematic side views of another variation of apparatus and a method for grasping and cinching a tissue anchor.

[0114] Figs. 53A to 53D show schematic views of a variation of the apparatus and method of Figs. 52.

[0115] Figs. 54A and 54B show schematic views illustrating use of the grasp-and-cinch apparatus of Figs. 53 in combination with the tissue plication apparatus of Figs. 1 and 2.

[0116] Fig. 55 shows schematic views of a variation of the apparatus and method of Figs. 53.

5 [0117] Figs. 56A and 56B show schematic views of additional variations of the apparatus of Figs. 53.

[0118] Figs. 57A to 57C show schematic views of a variation of the apparatus and method of Figs. 52.

10 [0119] Figs. 58A to 58D show schematic views of a variation of the apparatus and method of Figs. 51.

[0120] Figs. 59A to 59C show schematic views of another variation of apparatus and a method for grasping and cinching a tissue anchor.

15 [0121] Figs. 60A to 60D are, respectively, a perspective view, an end view, a detail side view of the distal end, and a side-sectional view of the distal end of a variation of the apparatus and method of Figs. 58.

[0122] Figs. 61A to 61D are, respectively, a perspective view, a detail side view of the proximal end, and detail side-sectional views of the proximal end of a variation of the apparatus and method of Figs. 60, illustrating a force feedback mechanism for controlling and/or monitoring cinching forces applied to an anchor assembly.

20 [0123] Figs. 62A to 62D are, respectively, a perspective view, a detail side view of the proximal end, and detail side-sectional views of the proximal end of an off-axis variation of the force feedback cinching apparatus and method of Figs. 61.

DETAILED DESCRIPTION OF THE INVENTION

25 [0124] In order to first create the plication within a body lumen of a patient, various methods and devices may be implemented. The anchoring and securement devices may be delivered and positioned via an endoscopic apparatus that engages a tissue wall of the gastrointestinal lumen, creates one or more tissue folds, and disposes one or more of the anchors through the tissue fold(s). The tissue anchor(s) may be disposed through the
30 muscularis and/or serosa layers of the gastrointestinal lumen.

[0125] Generally, in creating a plication through which a tissue anchor may be disposed within or through, a distal tip of a tissue plication apparatus may engage or grasp the tissue and move the engaged tissue to a proximal position relative to the tip of the device, thereby providing a substantially uniform plication of predetermined size.

5 [0126] Formation of a tissue fold may be accomplished using at least two tissue contact areas that are separated by a linear or curvilinear distance, wherein the separation distance between the tissue contact points affects the length and/or depth of the fold. In operation, a tissue grabbing assembly engages or grasps the tissue wall in its normal state (i.e., non-folded and substantially flat), thus providing a first tissue contact area. The first tissue contact area
10 then is moved to a position proximal of a second tissue contact area to form the tissue fold. The tissue anchor assembly then may be extended across the tissue fold at the second tissue contact area. Optionally, a third tissue contact point may be established such that, upon formation of the tissue fold, the second and third tissue contact areas are disposed on
15 opposing sides of the tissue fold, thereby providing backside stabilization during extension of the anchor assembly across the tissue fold from the second tissue contact area.

[0127] The first tissue contact area may be utilized to engage and then stretch or rotate the tissue wall over the second tissue contact area to form the tissue fold. The tissue fold may then be articulated to a position where a portion of the tissue fold overlies the second tissue contact area at an orientation that is substantially normal to the tissue fold. A tissue anchor
20 may then be delivered across the tissue fold at or near the second tissue contact area. An apparatus in particular which is particularly suited to deliver the anchoring and securement devices described herein may be seen in further detail in co-pending U.S. Pat. App. Serial No. 10/735,030 filed December 12, 2003 and entitled "Apparatus And Methods For Forming And Securing Gastrointestinal Tissue Folds", which is incorporated herein by reference in its
25 entirety.

[0128] An illustrative side view of a tissue plication assembly **10** which may be utilized with the tissue anchors described herein is shown in Fig. 1A. The plication assembly **10** generally comprises a catheter or tubular body **12** which may be configured to be sufficiently flexible for advancement into a body lumen, e.g., transorally, percutaneously,
30 laparoscopically, etc. Tubular body **12** may be configured to be torqueable through various methods, e.g., utilizing a braided tubular construction, such that when handle **16** is manipulated and rotated by a practitioner from outside the body, the torquing force is

transmitted along body 12 such that the distal end of body 12 is rotated in a corresponding manner.

5 [0129] Tissue manipulation assembly 14 is located at the distal end of tubular body 12 and is generally used to contact and form the tissue plication, as mentioned above. Fig. 1B shows an illustrative detail side view of tissue manipulation assembly 14 which shows launch tube 18 extending from the distal end of body 12 and in-between the arms of upper extension member or bail 20. Launch tube 18 may define launch tube opening 24 and may be pivotally connected near or at its distal end via hinge or pivot 22 to the distal end of upper bail 20. Lower extension member or bail 26 may similarly extend from the distal end of body 12 in a longitudinal direction substantially parallel to upper bail 20. Upper bail 20 and lower bail 26 need not be completely parallel so long as an open space between upper bail 20 and lower bail 26 is sufficiently large enough to accommodate the drawing of several layers of tissue between the two members.

15 [0130] Upper bail 20 is shown in the figure as an open looped member and lower bail 26 is shown as a solid member; however, this is intended to be merely illustrative and either or both members may be configured as looped or solid members. Tissue acquisition member 28 may be an elongate member, e.g., a wire, hypotube, etc., which terminates at a tissue grasper 30, in this example a helically-shaped member, configured to be reversibly rotatable for advancement into the tissue for the purpose of grasping or acquiring a region of tissue to be formed into a plication. Tissue acquisition member 28 may extend distally from handle 16 through body 12 and distally between upper bail 20 and lower bail 26. Acquisition member 28 may also be translatable and rotatable within body 12 such that tissue grasper 30 is able to translate longitudinally between upper bail 20 and lower bail 26. To support the longitudinal and rotational movement of acquisition member 28, an optional guide or sled 32 may be connected to upper 20 or lower bail 26 to freely slide thereon. Guide 32 may also be slidably connected to acquisition member 28 such that guide 32 supports the longitudinal motion of acquisition member 28.

25 [0131] An example of a tissue plication procedure is seen in Figs. 2A to 2D for delivering and placing a tissue anchor and is disclosed in further detail in co-pending U.S. Pat. App. Serial No. 10/735,030 filed December 12, 2003, which has been incorporated by reference above. Tissue manipulation assembly 14, as seen in Fig. 2A, may be advanced into a body lumen such as the stomach and positioned adjacent to a region of tissue wall 40 to be

plicated. During advancement, launch tube **18** may be configured in a delivery profile such that tube **18** is disposed within or between the arms of upper bail **20** to present a relatively small profile.

[0132] Once tissue manipulation assembly **14** has been desirably positioned relative to tissue wall **40**, tissue acquisition member **30** may be advanced distally such that tissue acquisition member **30** comes into contact with tissue wall **40** at acquisition location or point **42**. As acquisition member **30** is distally advanced relative to body **12**, guide **32**, if utilized, may slide distally along with member **30** to aid in stabilizing the grasper. If a helically-shaped acquisition member **30** is utilized, as illustrated in Fig. 2B, it may be rotated from its proximal end at handle **16** and advanced distally until the tissue at point **42** has been firmly engaged by acquisition member **30**. This may require advancement of acquisition member **30** through the mucosal layer and at least into or through the underlying muscularis layer and preferably into or through the serosa layer.

[0133] The grasped tissue may then be pulled proximally between upper **20** and lower bails **26** via acquisition member **30** such that the acquired tissue is drawn into a tissue fold **44**, as seen in Fig. 2C. As acquisition member **30** is withdrawn proximally relative to body **12**, guide **32** may also slide proximally to aid in stabilizing the device especially when drawing the tissue fold **44**.

[0134] Once the tissue fold **44** has been formed, launch tube **18** may be advanced from its proximal end at handle **16** such that a portion **46** of launch tube **18**, which extends distally from body **12**, is forced to rotate at hinge or pivot **22** and reconfigure itself such that portion **46** forms a curved or arcuate shape that positions launch tube opening **24** perpendicularly relative to a longitudinal axis of body **12** and/or bail members **20**, **26**. Launch tube **18**, or at least portion **46** of launch tube **18**, is preferably fabricated from a highly flexible material or it may be fabricated, e.g., from Nitinol tubing material which is adapted to flex, e.g., via circumferential slots, to permit bending. Alternatively, assembly **14** may be configured such that launch tube **18** is reconfigured simultaneously with the proximal withdrawal of acquisition member **30** and acquired tissue **44**.

[0135] As discussed above, the tissue wall of a body lumen, such as the stomach, typically comprises an inner mucosal layer, connective tissue, the muscularis layer and the serosa layer. To obtain a durable purchase, e.g., in performing a stomach reduction procedure, the staples or anchors used to achieve reduction of the body lumen are preferably engaged at

least through or at the muscularis tissue layer, and more preferably, the serosa layer. Advantageously, stretching of tissue fold 44 between bail members 20, 26 permits an anchor to be ejected through both the muscularis and serosa layers, thus enabling durable gastrointestinal tissue approximation.

5 [0136] As shown in Fig. 2D, once launch tube opening 24 has been desirably positioned relative to the tissue fold 44, needle assembly 48 may be advanced through launch tube 18 via manipulation from its proximal end at handle 16 to pierce preferably through a dual serosa layer through tissue fold 44. Needle assembly 48 is preferably a hollow tubular needle through which one or several tissue anchors may be delivered through and ejected from in
10 securing the tissue fold 44, as further described below.

[0137] Because needle assembly 48 penetrates the tissue wall twice, it exits within the body lumen, thus reducing the potential for injury to surrounding organs. A detail cross-sectional view is shown in Fig. 3A of anchor delivery assembly 50 in proximity to tissue fold F. In this example, tissue fold F may comprise a plication of tissue created using the apparatus 10
15 described herein or any other tool configured to create such a tissue plication. Tissue fold F may be disposed within a gastrointestinal lumen, such as the stomach, where tissue wall W may define the outer or serosal layer of the stomach. Anchor delivery assembly may generally comprise launch tube 18 and needle assembly 48 slidably disposed within launch tube lumen 52. Needle assembly 48 is generally comprised of needle 54, which is preferably
20 a hollow needle having a tapered or sharpened distal end 66 to facilitate its travel into and/or through the tissue. Other parts of the assembly, such as upper and lower bail members 20, 26, respectively, and tissue acquisition member 28 have been omitted from these figures only for clarity.

[0138] Once launch tube 18 has been desirably positioned with respect to tissue fold F,
25 needle 54 may be urged or pushed into or through tissue fold F via needle pushrod or member 56 from its proximal end preferably located within handle 16. Needle 54 may define needle lumen 58 within which distal anchor 62 and/or proximal anchor 64 may be situated during deployment and positioning of the assembly. A single suture or flexible element 70 (or multiple suture elements) may connect proximal anchor 64 and distal anchor 62 to one
30 another. For instance, element 70 may comprise various materials such as monofilament, multifilament, or any other conventional suture material, elastic or elastomeric materials, e.g., rubber, etc.

[0139] Alternatively, metals which are biocompatible may also be utilized for suture materials. For instance, sutures may be made from metals such as Nitinol, stainless steels, Titanium, etc., provided that they are formed suitably thin and flexible. Using metallic sutures with the anchoring mechanisms described herein may additionally provide several
5 benefits. For example, use of metallic suture material may decrease any possibilities of suture failure due to inadvertent cutting or shearing of the suture, it may provide a suture better able to withstand the acidic and basic environment of the gastrointestinal system, and it may also enhance imaging of the suture and anchor assembly if examined under conventional imaging systems such as X-rays, fluoroscopes, MRI, etc. As used herein, suture 70 may
10 encompass any of these materials or any other suitable material which is also biocompatible.

[0140] Needle 54 may optionally define needle slot 60 along its length to allow suture 70 to pass freely within and out of needle 54 when distal anchor 62 is ejected from needle lumen 58. Alternatively, rather than utilizing needle slot 60, needle 54 may define a solid structure with suture 70 being passed into needle lumen 58 via the distal opening of needle 54.

[0141] The proximal end of suture 70 may pass slidingly through proximal anchor 64 to terminate in suture loop 74 via cinching knot 72. Suture loop 74 may be omitted and the proximal end of suture 70 may terminate proximally of the apparatus 10 within control handle 16, proximally of control handle 16, or at some point distally of control handle 16. In this variation, suture loop 74 may be provided to allow for a grasping or hooking tool to temporarily hold suture loop 74 for facilitating the cinching of proximal 64 and distal 62 anchors towards one another for retaining a configuration of tissue fold F, as described in further detail below. Cinching knot 72 may also comprise a slidable knot which may be slid distally along suture 70 to lock or hold against proximal anchor 64 once the tissue fold F and anchors 62, 64 have been desirably positioned and tensioned, as also described below in
25 further detail.

[0142] After needle assembly 48 has been pushed distally out through launch tube opening 24 and penetrated into and/or through tissue fold F, as shown in Fig. 3B, anchor pushrod or member 68 may be actuated also via its proximal end to eject distal anchor 62, as shown in Fig. 3C. Once distal anchor 62 has been ejected distally of tissue fold F, Fig. 3D shows how
30 needle 54 may be retracted back through tissue fold F by either retracting needle 54 back within launch tube lumen 52 or by withdrawing the entire anchor delivery assembly 50 proximally relative to tissue fold F.

[0143] Fig. 3E shows that once needle 54 has been retracted, proximal anchor 64 may then be ejected from launch tube 18 on a proximal side of tissue fold F. With both anchors 62, 64 disposed externally of launch tube 18 and suture 70 connecting the two, proximal anchor 64 may be held against the distal end of launch tube 18 and urged into contact against tissue fold F, as shown in Figs. 3F and 3G, respectively. As proximal anchor 64 is urged against tissue fold F, proximal anchor 64 or a portion of suture 70 may be configured to provide any number of directionally translatable locking mechanisms which provide for movement of an anchor along suture 70 in a first direction and preferably locks, inhibits, or prevents the reverse movement of the anchor back along suture 70. In other alternatives, the anchors may simply be delivered through various elongate hollow tubular members, e.g., a catheter, trocars, etc.

[0144] With respect to the anchor assemblies described herein, the types of anchors shown and described are intended to be illustrative and are not limited to the variations shown. For instance, several of the tissue anchor variations are shown as "T"-type anchors while other variations are shown as reconfigurable "basket"-type anchors, which may generally comprise a number of configurable struts or legs extending between at least two collars or support members. Other variations of these or other types of anchors are also contemplated for use in an anchor assembly. Examples of anchors which may be utilized are disclosed in co-pending U.S. Pat. App. Serial No. 10/612,170, filed July 1, 2003, which is incorporated herein by reference in its entirety. Moreover, a single type of anchor may be used exclusively in an anchor assembly; alternatively, a combination of different anchor types may be used in an anchor assembly. Furthermore, the different types of cinching or locking mechanisms are not intended to be limited to any of the particular variations shown and described but may be utilized in any of the combinations or varying types of anchors as practicable.

[0145] To accomplish the secure placement of anchors having uni-directional anchor movement over the suture in a self-locking manner, various devices and methods may be utilized. Figs. 4A and 4B show side and end views, respectively, of one anchor variation 80 which is illustrated in the form of a T-type anchor. Although a T-type anchor is shown, the methods and devices used to cinch the anchor may be utilized in other types of anchors, which will be described below. Variation 80 may generally comprise an anchor body 82 having a circular, rectangular, square, etc., cross-section which defines openings 84 and 86 on opposing sides of the anchor 80. Locking block or member 88 may be slidably disposed within anchor body 82 and define a tapered face 90 on the side of block 88 which tapers to at

least one of the openings, in this case opening 86. Openings 84, 86 are preferably aligned with one another although this is not necessary.

[0146] Suture 94 may be routed through opening 84, around locking block 88, and back out through opening 86 such that when anchor body 82 is translated in the direction of arrow 96, anchor body 82 may slide freely over suture 94 due to the manner of tapered face 90 contacting suture 84 within opening 84. However, if anchor body 82 were translated in the opposite direction, tension within suture 94 may pull locking block 88 via suture 94 placed over contact surface 92 such that when block 88 translates in the direction of arrow 98, suture 94 at opening 86 is forced into groove 100 defined along the leading edge of block 88, as shown in Fig. 4B. This cleating action may effectively inhibit or prevent any further movement of anchor body 82 over suture 94. Accordingly, anchor body 82 may be moved uni-directionally relative to suture 94 and a distally located anchor to effectively cinch tissue therebetween.

[0147] Fig. 5 illustrates another cinching anchor in the side view of anchor variation 110. In this variation, anchor body 112 similarly defines openings 114 and 116 through which suture 96 may be routed. Locking block or member 118, which may similarly also define tapered face 120 may be slidably disposed within anchor body 112. Locking block 118 may be urged via a biasing member, for instance spring 122, to maintain a biasing force against suture 94 passing through anchor body 112. As anchor body 112 is translated over suture 94 in the direction of arrow 96, tapered face 120 may allow suture 94 to pass freely between openings 114, 116. However, if anchor body 112 were to be moved in the opposite direction, biasing member 122 may force locking block 118 to exert a force at its leading edge against suture 94, thereby preventing its movement and allowing only uni-directional movement.

[0148] Yet another locking anchor variation 130 is shown in the side view in Fig. 6. In this variation, anchor body 132 also defines openings 134, 136 through which suture 94 may pass. Within anchor body 132, multiple locking blocks or members 138, 140 may be configured to become biased in opposing directions via biasing members or springs 142, 144, respectively. Each of locking blocks 138, 140 may define an opening through which suture 94 may pass. Thus, when anchor body 132 is slowly moved over suture 94 in a first direction, the anchor may translate freely. However, when moved quickly in the opposite direction, the biasing members 142, 144 may urge their respective locking blocks 138, 140 in directions 146, 148

to create a tortuous path through the blocks and inhibit or prevent the reverse movement of anchor body 132 relative to suture 94.

[0149] Fig. 7 shows a perspective view of another locking anchor variation 150 in which anchor body 152 defines an opening 154 having a tapered or grooved portion 156. Opening 154 may be sized to allow suture 94 to pass through opening 154 such that anchor body 152 may be translated freely relative to suture 94. Once anchor body 152 has been desirably positioned relative to the tissue fold or to the opposing anchor, suture 94 may be manipulated to slide into tapered or grooved portion 156, which preferably defines a diameter which is less than a diameter of suture 94. Sliding suture 94 into tapered or grooved portion 156 may lock a position of anchor body 152 relative to suture 94 due to the cleating effect of grooved portion 156 on suture 94.

[0150] Figs. 8A and 8B show cross-sectional side and top views, respectively, of another locking anchor variation 160 in which anchor body 162 may define a through-hole passage or opening 164 through which suture 94 may pass. Anchor body 162 may have one or several levered, flapped, or biased locking members 166 which may be integrally formed with anchor body 162. These locking members 166 may be formed radially about opening 164 such that when suture 94 is absent, the resting configuration of locking members 166 define an opening 164 having a diameter less than that of the suture 94 passed through. Locking members 166 may be biased to protrude in a single direction, as shown in Fig. 8A, such that when anchor body 162 is moved in a first direction over suture 94, the anchor 162 passes freely. However, when anchor body 162 is moved in the opposing direction over suture 94, locking members 166 engage onto suture 94 and prevent any reverse translation, thereby enabling uni-directional movement and locking of anchor body 162. Although five locking members 166 are shown, any number of members may be utilized as practicable and as desired to effect a desired degree to locking.

[0151] Fig. 8C shows a cross-sectional side view of anchor body 162 in combination with a modified suture 168 having integrated features or protrusions 170 defined along its length. Features or protrusions 170 may be defined uniformly at regular intervals along the length of suture 168 or intermittently, depending upon the desired effects, to enhance the locking ability of the anchor body onto the suture. Moreover, the features or protrusions 170 may be integrally formed protrusions or they may simply comprise knotted sections of suture. Sutures which are modified or knotted may be optionally utilized in any of the locking anchor

variations as described herein in place of conventional sutures, depending upon the desired degree of locking and locking effects.

[0152] As shown in the cross-sectional views of Figs. 9A and 9B of locking anchor variations **180** and **188**, respectively, anchor body **182** may also comprise biased locking members **184**, contained within the anchor body **182**. The number and configuration of locking members **184** may be varied as desired and may optionally be apposed, as shown in Fig. 9A, or utilize a single member **184**, as shown in anchor variation **188** in Fig. 9B. The figures show knotted suture **186** used with anchor variation **180**; however, conventional sutures may also be utilized.

10 [0153] Fig. 9C shows another modification of suture **94** which may be utilized with any of the anchor locking variations shown herein. The portions of suture **94** which come into contact with the anchor locking mechanisms may be coated with a material having a relatively higher frictional coefficient, i.e., a coefficient of friction that is higher than the underlying suture material. For example, the portion of suture **94** may be coated with a metallic covering or slid within sleeve **181**, which may be made of a metallic material such as Titanium, Nitinol, stainless steel, etc. to enhance the locking force between suture **94** and the anchor. As shown in the figure, if sleeve **181** is utilized, the ends **183**, **185** of sleeve **181** may be crimped onto suture **94**. One or several openings **187** may also be defined along sleeve **181** to further enhance the locking capability between suture **94** and the locking mechanism.

20 [0154] Aside from the use of mechanical locking features integrated within or with the anchor bodies, locking mechanisms may also utilize a variety of knotting techniques. Conventional knots, which are typically tied by the practitioner either within the body or outside the body and advanced over the suture length, may be utilized for locking the anchor in place relative to the tissue fold and opposing anchor; however, self-locking knots which enable the uni-directional travel of an anchor body relative to the suture and tissue are desirable.

25 [0155] Fig. 10 shows locking anchor assembly **190** with distal anchor **192**, which may be positioned distally of a tissue fold, and proximal anchor **194**, which may be positioned proximally of a tissue fold or folds. In this variation, suture **94** may be routed through proximal anchor **194** via openings **196**, **198** and extended to distal anchor **192**. At distal anchor **192**, suture **94** may be routed through opening **200** and over pin **202** positioned within distal anchor **192**. Pin **202** may function as a pulley over which suture **94** may travel during

anchor locking adjustments. Suture 94 may then be routed back towards proximal anchor 194 through opening 204 and define loop 206 through which the proximal portion of suture 94 passes to thereby create a choke-type loop. The terminal end of suture 94 may then be anchored at fixed end 208 within the body of proximal anchor 194.

5 [0156] In operation, when tension is applied to suture 94 or when proximal anchor 94 is advanced distally, proximal anchor 194 and distal anchor 192 may be freely drawn towards one another to secure any tissue fold or folds (not shown for clarity) disposed therebetween. However, if proximal anchor 194 were pulled or urged in the opposite direction away from the tissue or from distal anchor 192, loop 206 would “choke” suture 94 and prevent any
10 reverse movement of proximal anchor 194.

[0157] Fig. 11A shows a perspective view of locking anchor assembly 210 having distal anchor 212 and proximal anchor 214 with suture 94 extending between the two anchors. Terminal end 230 of suture 94 may be knotted or otherwise retained by proximal anchor 214 and routed through opening 216 and back through opening 218 to create looped portion 228,
15 both openings 216, 218 being defined in proximal anchor 214. Suture 94 may be routed from opening 218 and through distal anchor 212 via openings 222, 224. Suture 94 may then be routed back to proximal anchor 214 through an opening 220 and wrapped 226 about looped portion 228 to continue on proximally. This knotted configuration facilitates advancement of proximal anchor 214 towards distal anchor 212 but chokes suture 94 when proximal anchor
20 214 is moved in an opposing direction.

[0158] Figs. 11B and 11C show top and cross-sectional side views of an alternative variation on proximal anchor 214 (and distal anchor 212, if desired). As shown, anchor 214 may optionally define grooves or channels 232 which extend at least partially between openings 216, 218, and 220. These grooves or channels 232, as seen in Fig. 11C, may be
25 sized such that any of the overlying suture 94 are cinched or wedged into grooves 232 to facilitate the cinching action of anchor 214 with respect to suture 94.

[0159] Another locking anchor assembly 240 is shown in the perspective view of Fig. 12A, which shows distal anchor 242 and proximal anchor 244 with suture 94 extending between the two anchors. Suture 94 may be routed through opening 246 defined through proximal
30 anchor 244 and passed through distal anchor 242 via openings 250, 252. Suture 94 may then be routed back towards proximal anchor 244 and passed through opening 248 to create at least two adjacent loops (half hitch knots) 254, 256 with looped section 258. During cinching

of proximal anchor 244 against the tissue, the knotted suture may be slid distally with proximal anchor 244. Once proximal anchor 244 has been desirably positioned along suture 94, the terminal end of suture 94 may be pulled, as shown by arrow 260, to alter the knot configuration, commonly called changing the dressing of the knot, such that the knot
5 becomes locked onto suture 94 and prevents any reverse movement of proximal anchor 244.

[0160] Fig. 12B also shows a perspective view of another locking anchor variation similar to that shown in Fig. 12A. In this variation, suture 94 may be wrapped into two intertwined loops 264, 266 and further wrapped again into adjacent intertwined loops 262, 268. Distal advancement of the knotted configuration along with proximal anchor 244 may be
10 accomplished until the terminal end of suture 94 is placed under tension, as shown by arrow 260. Tension may be applied once proximal anchor 244 has been desirably positioned along suture 94 to lock the knot into position and prevent any reverse movement of proximal anchor 244 along suture 94.

[0161] Fig. 12C shows a perspective view of another anchor locking assembly similar to
15 the variations above. The knot may be modified by wrapping suture 94 into a first set of several loops, shown as three loops 270, 272, 274, although in other variations, any number of loops may be utilized depending upon the desired locking effects. Suture 94 may then be wrapped in a second set of several additional loops in a proximally adjacent position about suture 94, shown as loops 278, 280, 282 joined by looped section 276. Likewise, any number
20 of loops in the second set may be utilized either independent of the number of loops in the first set or to mirror the first set of loops. In either situation, once suture terminal end 284 is tightened, a knotted configuration, as shown in Fig. 12D, is formed which may be freely slid along suture 94 provided the knotted configuration itself is pushed along suture 94, e.g., via a pusher tube, knot pusher, etc. However, once tension is applied along suture 94 by proximal
25 anchor 244 pushing against the knot and by the tension created in the suture extending between anchors 242, 244, the knot locks against suture 94 and prevents reverse movement of proximal anchor 244 along suture 94.

[0162] Fig. 12E shows a perspective view of another locking anchor variation similar to the variation shown in Fig. 12D yet having a single suture traverse between anchors 242, 244. In
30 this variation, suture 94 may have terminal end 286 anchored or retained by distal anchor 242 at opening 252 and have a single suture traverse to proximal anchor 244. A second terminal end 288 may also be anchored or retained by proximal anchor 244 at opening 246. The

portions of suture **94** extending between proximal anchor **244** and the knot may have a biasing member, e.g., spring **290**, disposed over one or both lengths of suture to maintain proximal anchor **244** and the knot under a constant force to ensure that the knot is maintained under a locking force to prevent the reverse travel of proximal anchor **244**.

5 [0163] Yet another variation of a locking anchor variation having a single suture traversing the anchors is shown in the perspective view of Fig. 12F. A terminal end **252** of suture **94** may be anchored or retained at distal anchor **242** and routed to proximal anchor **214** through opening **218**. The length of suture **94** may form loop **292** on a first side of proximal anchor **214** and a second loop **296** on the opposite side of proximal anchor **214** between openings
10 **216, 220**. Suture **94** may then be wrapped about loop **292** via loop **294** on the first side to form an interlocking suture loop. This variation is also effective in allowing proximal anchor **214** to translate over suture **94** towards the tissue and distal anchor **242** yet prevent reverse movement of proximal anchor **214** due to a choking action by the intertwined suture loops on the proximal side of proximal anchor **214**.

15 [0164] Fig. 12G shows a perspective view of another locking anchor variation similar to that shown in Fig. 12F. Here, suture **94** may be routed through opening **220** in proximal anchor **214** to form loop **292** before being passed through openings **218** and **216** and intertwining loop **294** through loop **292**. Likewise, this variation is also effective in allowing proximal anchor **214** to translate over suture **94** towards the tissue and distal anchor **242** yet
20 prevent reverse movement of proximal anchor **214**.

[0165] As mentioned above, the locking and cinching mechanisms described herein may be utilized with a variety of different anchor types. For instance, the cinching mechanisms described above may be used not only with T-type anchors but also with reconfigurable basket-type anchors. Described hereinafter are basket-type anchors configured for
25 implantation or placement against tissue in a similar manner as described previously and examples of how cinching mechanisms may be utilized in securing tissue plications. Moreover, additional cinching mechanisms which are preferably utilizable with basket-type anchors are also described below.

[0166] When cinching or locking basket-type anchors, the baskets may be delivered into or
30 through the tissue in the same or similar manner as described above, particularly as shown in Figs. 3A-3G. For example, Fig. 13A shows anchor delivery system **300** in proximity to tissue fold **F**. Again, tissue fold **F** may be disposed within a gastrointestinal lumen, such as

the stomach, where tissue wall *W* may define the outer or serosal layer of the stomach. Delivery push tube or catheter 302 may be disposed within launch tube 18 proximally of basket anchor 306, which is shown in a compressed delivery configuration with a relatively low profile when disposed within needle lumen 58 of needle 54. A single basket anchor 306 is shown disposed within needle 54 only for illustrative purposes and is not intended to be limited by the number of basket anchors; rather, any number of basket anchors may be disposed within needle lumen 58 as practicable depending upon the desired procedure and anchoring results.

[0167] Suture 94 may be routed through or externally of push tube lumen 304 and further routed within and/or through proximal collar 310 of anchor 306. The terminal end of suture 94 may be routed within anchor 306 and affixed to distal collar 308 in one variation. Alternatively, suture 94 may be affixed or anchored within anchor 306 or at proximal collar 310 depending upon the desired effect and procedure being performed. Moreover, if multiple anchors are utilized in a tissue plication procedure, suture 94 may be routed through anchor 306 such that the anchor 306 may freely slide along or over suture 94.

[0168] The basket anchors may comprise various configurations suitable for implantation within a body lumen. Basket anchors are preferably reconfigurable from a low profile delivery configuration to a radially expanded deployment configuration in which a number of struts, arms, or mesh elements may radially extend once released from launch tube 18 or needle 54. Materials having shape memory or superelastic characteristics or which are biased to reconfigure when unconstrained are preferably used, e.g., spring stainless steels, Ni-Ti alloys such as Nitinol, etc. The basket anchor 306 is illustrated as having a number of reconfigurable struts or arm members 312 extending between distal collar 306 and proximal collar 310; however, this is intended only to be illustrative and suitable basket anchors are not intended to be limited to baskets only having struts or arms. Examples of suitable anchors are further described in detail in U.S. Pat. App. Serial No. 10/612,170, which has already been incorporated herein above.

[0169] Fig. 13A shows basket anchor 306 delivered through tissue fold *F* via needle 54 and launch tube 18. As above, the other parts of the plication assembly, such as upper and lower bail members 20, 26, respectively, and tissue acquisition member 28 have been omitted from these figures only for clarity.

[0170] Fig. 13B shows one variation where a single fold F may be secured using basket anchor 306'. As seen, basket anchor 306' has been urged or ejected from needle 54 and is shown in its radially expanded profile for placement against the tissue surface. In such a case, a terminal end of suture 94 may be anchored within the distal collar of anchor 306' and routed through tissue fold F and through, or at least partially through, proximal anchor 318, where suture 94 may be cinched or locked proximally of, within, or at proximal anchor 318 via any number of cinching mechanisms 316 described herein. Proximal anchor 318 is also shown in a radially expanded profile contacting tissue fold F along tissue contact region 314. Locking or cinching of suture 94 proximally of proximal anchor 318 enables the adequate securement of tissue fold F.

[0171] If additional tissue folds are pliated for securement, distal basket anchor 306 may be disposed distally of at least one additional tissue fold F', as shown in Fig. 13B, while proximal anchor 318 may be disposed proximally of tissue fold F. As above, suture 94 may be similarly affixed within distal anchor 306 and routed through proximal anchor 318, where suture 94 may be cinched or locked via proximal anchor 318, as necessary. If tissue folds F and F' are to be positioned into apposition with one another, distal basket anchor 306 and proximal anchor 318 may be approximated towards one another. As described above, proximal anchor 318 is preferably configured to allow suture 94 to pass freely therethrough during the anchor approximation. However, proximal anchor 318 is also preferably configured to prevent or inhibit the reverse translation of suture 94 through proximal anchor 318 by enabling uni-directional travel of anchor 318 over suture 94. This cinching feature thereby allows for the automated locking of anchors 306, 318 relative to one another during anchor approximation.

[0172] Aside from the anchor cinching or locking mechanisms utilizing looped and knotted sutures for facilitating uni-directional locking, various mechanisms utilizing friction may also be implemented. Figs. 14A and 14B show cross-sectional side views of one variation in cinching assembly 320. Proximal collar 322, proximal portions of struts 312, and distal portions of launch tube 18 are shown and other features of the assembly and tissue fold F have been omitted from the figure only for clarity.

[0173] A locking or cinching collar or collet 326 may be positioned within launch tube 18 proximally of anchor collar 322. Cinching collet 326 may comprise a cylindrically shaped member defining a lumen therethrough for passage of suture 94. A distal end of cinching

collet 326 may have at least one and preferably several clamping arms or teeth 328 which are configured to cinch or clamp down upon suture 94 passing through. Proximal anchor collar 322 may be sized to correspondingly receive cinching collet 326 therewithin to create an interference fit. relative to an outer diameter of cinching collet 326. A distal portion of anchor collar 322 may also define a tapered or angled portion 324 such that when cinching collet 326 is advanced within anchor collar 322, angled portion 324 may effectively force clamping arms or teeth 328 to cinch radially inward upon suture 94.

[0174] In operation, once proximal anchor 318 has been desirably positioned relative to tissue fold **F** and/or the distal anchor and with proximal collar 322 positioned within launch tube 18, delivery push tube 302 may be advanced distally to urge cinching collet 326 into anchor collar 322 such that clamping arms or teeth 328 are clamped onto suture 94 and cinching collet 326 is friction-fitted within anchor collar 322. Anchor collar 322 may then be urged out of launch tube 18 and the anchor left against the tissue surface.

[0175] Another cinching assembly variation 330 is shown in the cross-section view of Figs. 15A and 15C. Launch tube 18 has been omitted from these figures for clarity only. Delivery push tube 332 is shown as defining suture lumen 334 and locking member or pin lumen 336 therethrough. Although two separate lumens are shown, a single common lumen may be utilized in alternative variations. With proximal anchor collar 344 positioned distally of push tube 332, suture 94 may be routed through suture lumen 334 and through collar lumen 346. Locking member or pin 338 may be positioned within lumen 336 proximally of collar lumen 326. Fig. 15B shows an end view of push tube 332 with locking pin 338 and suture 94 positioned within prior to cinching of the anchor.

[0176] Once the anchor has been desirably positioned relative to the tissue, suture 94 may be pulled proximally such that anchor collar 344 rests against the distal end of push tube 332. Locking pin 338, which may define a tapered or radiused end 340 to facilitate its insertion into collar lumen 346, may be urged distally via push rod 342 to force locking pin 338 into anchor collar 344 such that the portion of suture 94 within anchor collar 344 becomes effectively wedged and thereby prevents further movement of the anchor along suture 94. Fig. 15C shows a cross-sectional side view of locking pin 388 having been urged into anchor collar 344 in a frictional engagement with suture 94. Fig. 15D shows a cross-sectional end view of collar 344 with locking pin 388 and suture 94 positioned within.

[0177] Fig. 15E shows a perspective view of another cinching variation 331 which is similar to the variation described above. One or more tapered pins or blocks 339 may be slidably disposed within tapered channel 335 defined in proximal collar 333. The figure shows two tapered pins 339, although a single pin may be utilized or more than two pins may also be used. If two or more pins 339 are utilized, suture 94 may be passed between the pins 339. Pins 339 may be free to slide along inner surface 337 of channel 335 in the direction of arrows 345 depending upon the direction of travel of suture 94 through channel 335. Fig. 15F shows a perspective view of only pins 339 for clarity; as seen, pins 339 may be tapered distally from a larger diameter to a smaller diameter and although pins 339 are shown as semi-circularly shaped members, contact surface 341 may be curved or arcuate to better contact suture 94. Moreover, contact surface 341, which contacts suture 94 passing through channel 335, may define a roughened surface or it may alternatively define a plurality of serrations, teeth, projections, etc., to facilitate contact against suture 94.

[0178] In use, as proximal collar 333 is translated in the direction of arrow 343, pins 339 may be forced proximally such that suture 94 may pass freely through channel 335. However, if proximal collar 333 were to be translated in the opposing direction, pins 339 may be forced in the opposite direction to cinch down upon suture 94 within channel 335 and thereby inhibit any further motion.

[0179] An alternative variation of the assembly is shown in the cross-sectional views of Figs. 15G and 15H, which show a cinching anchor having a retractable pin. Fig. 15G shows proximal collar 347 with one or more retracting arms 349 extending proximally from collar 347. Retracting arms 349 may be configured to pivot at bend 353 when urged via a compression force applied at bend 353 in the direction of arrows 355. The application of this compression force may urge pin support collar 357 which is defined at a proximal portion of arms 349, to move in the direction of arrow 359. This in turn may move pin 351, which extends from pin support collar 357, proximally out of proximal collar 347 to thereby release suture 94 from its locked position. In one variation, retracting arms 349 may be biased to retain pin 351 within proximal collar 347 unless a compression force is applied at bend 353.

[0180] Figs. 16A and 16B show cross-sectional side views of another variation of cinching assembly 350. Cinching assembly 350 may generally comprise outer tubing 352 and inner tubing 358 rotatably positioned within outer tubing lumen 354. Cinching member 362 may be positioned distally of outer tubing 352 and may generally comprise a collar base 364 and

cinching collar **374** projecting proximally from collar base **364**. Cinching collar **374** is preferably tapered and threaded and may also be longitudinally slotted such that rotatable collar **368** may be rotatably disposed upon slotted cinching collar **374**. A distal end of outer tubing **352** may define one or several engaging members **356** which are adapted to

5 engagingly contact detents or keyed engagement interfaces **366** located on collar base **364**. Inner tubing **358** may also define one or several engaging members **363** which are also adapted to engagingly contact detents or keyed engagement interfaces **372** located on the rotatable cinching collar **374**. Suture **94** may be routed through inner tubing lumen **360**, through cinching collar **374**, and through proximal anchor collar **310**.

10 **[0181]** In operation, suture **94** may pass freely through assembly **350**. Once the anchor has been desirably positioned, engaging members **356** on outer tubing **352** may be correspondingly engaged against interface **366** and engaging members **363** on inner tubing **358** may be engaged against interface **372**. With suture **94** tensioned appropriately, outer tubing **352** may be held stationary while inner tubing **358** is rotated to torque rotatable collar

15 **368** about threaded cinching collar **374**. As rotatable collar **368** is torqued onto cinching collar **374**, the tapered shape may urge the slotted members to cinch upon suture **94** passing therethrough. Stand-offs **370**, which may protrude from rotatable collar **368**, may be adjusted in height to control how far rotatable collar **368** may be torqued onto collar base **364** such that the degree to which rotatable collar **368** is torqued about cinching collar **374** may be

20 desirably adjusted. Once the cinching collar **374** has been desirably cinched onto suture **94**, proximal anchor collar **310** may be ejected from launch tube **18** along with the cinching assembly, as shown in Fig. 16B.

[0182] Another variation on cinching assembly **380** may be seen in the cross-sectional views of Figs. 17A and 17B. Assembly **380** is similar to cinching assembly **330** shown above

25 in Figs. 15A to 15D. Delivery push tube **332** and push rod **342** have been omitted from these figures only for clarity. In this variation, when locking pin **338** is pushed distally into proximal collar **388**, a retaining tube member **384** may be utilized to provide a counterforce to stabilize proximal collar **388** during cinching. Retaining tube member **384** may generally comprise one or several collar engaging arms **386** for engaging proximal anchor collar **388** at

30 collar detents **390** defined along anchor collar **388**. During the insertion of locking pin **338** into collar **388**, collar engaging arms **386** may be positioned within launch tube **18** or within retractable sleeve **382**. After locking pin **338** has been inserted within anchor collar **388**, engaging arms **386** may be advanced distally out of launch tube **18** or retractable sleeve **382**

may be withdrawn proximally to expose engaging arms 386. Once free of any constraining forces, engaging arms 386 may be biased to spring or open radially to then release proximal anchor collar 388 in a cinched configuration.

[0183] Another variation on cinching assembly 400 is shown in Figs. 18A to 18D, in which proximal anchor collar 406 may comprise one or several biasing members or cinching tabs 408 within collar 406. Each of the tabs 406 may be biased to project inwardly such that suture 94 passing through is automatically cinched and locked in position, as shown in Fig. 18A. A suture release member 404, which may generally comprise a cylindrically shaped tube or member having a tapered surface 410 and a suture lumen 412 defined therethrough, may be positioned within anchor collar 406 during anchor positioning to allow free passage of suture 94 through the anchor, as shown in Fig. 18B. Fig. 18C shows an end view of release member 404 defining suture lumen 412 extending therethrough. Fig. 18D shows a perspective view of release member 404 to show tapered surface 410 and suture lumen 412 in better detail. Tapered surface 410 may be omitted but is preferably to facilitate the insertion and removal of release member 404 from anchor collar 406. When the anchor has been desirably positioned and is ready to be locked in place over suture 94, tubular member 402 may engage suture release member 404 for withdrawal from anchor collar 406. The removal of release member 404 may cause cinching tabs 408 to lock upon suture 94 and prevent the further movement of the anchor relative to suture 94.

[0184] Figs. 19A and 19B show another variation of cinching assembly 420 in which a deformable cinching member 424 may be positioned within the anchor distally of anchor collar 422. Cinching member 424 may define a tapered outer surface such that when the anchor is ready to be secured to suture 94, the insertion of cinching member 424 into collar 422 may compress cinching member 424 about suture 94 such that any further movement of the anchor is prevented. Cinching member 424 may be pulled into anchor collar 422 via pull wire 426, which may be manipulated at its proximal end by the surgeon or user when desired.

[0185] Figs. 20A to 20D show cross-sectional views of another variation in cinching assembly 430. As shown in Fig. 20A, proximal anchor collar 432 may comprise a pivotable locking member 434 contained either within anchor collar 432 or proximally of collar 432. This example illustrates locking member 434 contained within collar 432. Suture 94 may pass through locking member 434, which is shown in the end view of collar 432 in Fig. 20B, as having two pivots 436. Moreover, locking member 434 and pivots 436 may be integrally

formed from proximal collar 432. Pivoting locking member 434 may be biased to rotate about pivot 436 such that a resting position of locking member 434 is against an inner surface of collar 432. During distal anchor translation over suture 94, tension as represented by arrow 438, on suture 94 may force pivot 434 into an open position where suture 94 may pass
5 freely through. Upon having desirably positioned the anchor against tissue, locking member 436 may be biased to pivot in direction 440 to lock suture 94 against the inner surface of collar 432. Opposite movement of the anchor relative to suture 94 may act to further cinch locking member 434 against suture 94 and thereby further inhibit the movement of the anchor in the reverse direction.

10 [0186] A similar variation is shown in the cross-sectional side and perspective views of Figs. 20E and 20F, respectively. In this variation, locking member 434' may extend proximally of proximal collar 432 at an angle relative to collar 432. Locking member 434' may be pivotable via pivot 436' such that locking member 434' may pivot in the direction of the arrows shown depending upon the direction which the tissue anchor is translated relative
15 to suture 94. If proximal collar 432 is translated distally over suture 94, it may travel freely; however, if proximal collar 432 is translated proximally in the opposite direction, suture 94 may become wedged in a tapered portion of opening 442 through which suture 94 passes. Once suture 94 is wedged in tapered opening 442, locking member 434' may pivot towards proximal collar 432, where it is stopped from further motion, thereby locking the tissue
20 anchor onto suture 94 and preventing its reverse motion.

[0187] Figs. 21A and 21B show another cinching assembly variation 450 as seen in the cross-sectional side views. In this variation, delivery push tube 452 may be disposed proximally of locking collar 454 and proximal tapered anchor collar 458. Once the anchor has been desirably positioned relative to the tissue fold F, with suture 94 under tension,
25 locking collar 454 may be urged distally via push tube 452 such that locking collar 454 slides over proximal anchor collar 458. An inner surface of locking collar 454 may be tapered and anchor collar 458 may also be tapered in a correspondingly opposed manner such that when locking collar 454 is mated with anchor collar 458, anchor collar 458 may cinch locking collar 454 upon suture 94 to thereby prevent any further movement of the anchor over suture
30 94. Both collars may be made from any of the same or similar materials, as described above.

[0188] In addition to friction-based locking and cinching mechanisms utilizable in tissue anchors, other mechanisms which create tortuous paths for the suture within or through the anchors may also be utilized for creating uni-directional locking.

5 [0189] One cinching anchor variation 460 is shown in the cross-sectional side view in Fig. 22A. As shown, suture 94 may be routed through anchor proximal collar 462 and looped over pulley or pin 466 contained within distal collar 464. Suture 94 may then be routed back through and looped 468 about suture 94 and tied with slip knot 470. As tension is applied to suture 94, slip knot 470 may prevent further movement of the anchor relative to suture 94.

10 [0190] Figs. 22B and 22C show a variation which may be used in combination with cinching anchor variation 460 or alone. Pin 474 may optionally be positioned within proximal collar 462 and suture 94 may be wrapped or looped about itself around pin 474 in a manner as shown in the detail view of Fig. 22C. The configuration of loop 472 may allow for the uninhibited translation of the anchor in the direction of the arrow as shown; however, when the anchor is moved in the opposite direction, loop 472 may effectively cinch upon
15 itself to thus prevent or inhibit the reverse motion of the anchor relative to suture 94.

[0191] Another cinching variation is shown Figs. 22D and 22E. Suture 94 may be routed through proximal collar 462 with an additional length of cinching suture 476. The distal end of cinching suture 476 may form loop 478 which is wrapped about suture 94 and free to slide over suture 94. After the anchor has been desirably positioned relative to the tissue and with
20 suture 94 preferably under tension, cinching suture 476 may be pulled proximally such that loop 478 is pulled into proximal collar 462 and becomes wedged against suture 94. The multiple lengths of suturing material utilized for loop 478 and suture 94 preferably form a cross-sectional area which is larger than an inner diameter of proximal collar 462 such that positioning loop 478 and suture 94 within collar 462 ensures a frictional lock which prevents
25 further movement of the suture 94 relative to the anchor. Suture 94 and cinching suture 476 are preferably made from the same or similar materials although differing suture materials may also be used.

[0192] Fig. 23 shows a cross-sectional view of cinching assembly variation 480 in which proximal collar 482 may comprise pulley or pin 484 about which suture 94 may be looped
30 once or several times 490. Distal collar 486 may also comprise pulley or pin 488 about which suture 94 may also be looped once or several times before being wrapped or looped 492 back about suture 94. The terminal end of loop 492 may be secured about suture 94 via

slip knot **494**. This configuration of looping allows for the anchor to be advanced uni-directionally relative to the suture and tissue, yet prevents or inhibits the reverse movement of the anchor and thus effectively enables the tissue to be cinched via the anchors.

[0193] Another cinching or locking anchor variation **500** is shown in the cross-sectional view of Fig. 24A. In creating a tortuous path for suture **94**, cinching sleeve **506** may be positioned proximally of proximal collar **504** within or distally of delivery push tube **502**. Cinching sleeve **506** may generally comprise a tubular structure having sleeve lumen **510** defined therethrough and a number of openings **508** defined along the length of sleeve **506**. Openings **508** may be uniformly patterned along sleeve **506** or they may be randomly positioned. Moreover, any number of openings **508** may be utilized as practicable. In either case, suture **94** may be routed in various patterns throughout openings **508** and through sleeve lumen **510** before being routed through proximal collar **504**. Once the anchor is to be locked, cinching sleeve **506** may be urged distally via delivery push tube **502**. When urged or pushed distally, this may be done slowly so as to allow suture **94** to pass through the tortuous path created by suture **94** passing through openings **508**. However, once cinching sleeve **506** has been advanced proximally adjacent to proximal collar **504**, cinching sleeve **506** may become locked with proximal collar **504** pressing against sleeve **506**.

[0194] Fig. 24B shows another variation of a cinching mechanism which utilizes a tortuous path. Cinching sleeve **512** may comprise a tubular structure having an opening **514** defined along a surface of sleeve **512** through which suture **94** may pass. Cinching sleeve **512** may be disposed within proximal collar **504** with suture **94** routed from outside of sleeve **512** and passing to within sleeve **512** through opening **514**. In operation, because of the manner in which suture **94** is routed through sleeve **512** and into the anchor, distal translation of the anchor relative to the tissue and suture **94** is uninhibited. But when the anchor is reversed in direction relative to suture **94**, suture **94** and cinching sleeve **512** may be drawn into the anchor and become locked due to the interference between suture **94**, cinching sleeve **512**, and proximal collar **504**. Accordingly, an outer diameter of cinching sleeve **512** is preferably sized to be slightly less than an inner diameter of proximal collar **504** such that when suture **94** is passed through opening **514**, cinching sleeve **512** becomes wedged against collar **504**. Cinching sleeve **512** may be made from any of the same or similar materials as the anchors, as described above.

[0195] Figs. 24C and 24D show another variation similar to cinching sleeve 512 described above. Cinching sleeve variation 516 may be similarly sized as sleeve 512 and may also similarly define an opening 514; however, sleeve 516 includes one or several retaining arms 518 defined on a distal end of sleeve 516. Any number of retaining arms 518 may be utilized provided that they extend radially and reside distally of proximal collar 504 such that they prevent sleeve 516 from sliding proximally out of collar 504. Fig. 24D shows a perspective view of cinching sleeve 516 with retaining arms 518 radially extended from the body of sleeve 516. Cinching sleeve 516 may also be made from the same or similar material as the anchor; for example, sleeve 516 may be fabricated from a material having superelastic characteristics, such as Nitinol. Accordingly, when cinching sleeve 516 is initially inserted through collar 504 and/or during anchor delivery through launch tube 18 into or through the tissue, retaining arm or arms 518 may be configured into a low profile with arm or arms 518 constrained into a tubular shape. Upon anchor release or upon being inserted through collar 504, retaining arms 518 may be released to extend radially.

[0196] Yet another variation 520 on cinching assembly is shown in Fig. 25A. Generally, assembly variation 520 may comprise cinching collar 522 located proximally of anchor proximal collar 524. Cinching collar 522 may be a tubular structure having superelastic material characteristics, such as those found in Nitinol. Obstructing members 526, which may be formed from portions of cinching collar 522, may be pressed or formed to extend into a lumen of cinching collar 522 such that a tortuous path is created for the passage of suture 94. Although three obstructing members 526 are shown in the figure, any number of obstructions as practicable may be created depending upon the desired tortuous path to be created.

[0197] Assembly 520 shows cinching collar 522 as a separate collar located proximally of anchor collar 524; however, the cinching collar may be integrated with the anchor collar such that a singular integral structure is formed, as shown in anchor variation 530 in the cross-sectional view of Fig. 25B. In either alternative during anchor placement relative to the tissue fold, retaining sleeve 534 may be inserted within cinching collar 522 to maintain obstructing members 526 in an open position for allowing suture 94 to pass freely through sleeve 534. Once the anchor has been desirably positioned, retaining sleeve 534 may be withdrawn, as shown in the perspective view of Fig. 25C, using any number of methods. Removal of retaining sleeve 534 will allow for obstructing members 526 to reconfigure

inwardly in the direction of arrows 532 to thus reconfigure cinching collar 522 into a tortuous path.

[0198] Cinching assembly 540 may also utilize a single or any number of tabs or levers to aid in capturing suture 94 and/or creating a tortuous path for suture 94 to traverse. As shown in the cross-sectional view of Fig. 26A, proximal collar 542 may have a pivoting lever 544 formed integrally from a side wall of proximal collar 542. Alternatively, lever 544 may be included in a cinching collar separate from proximal collar 542. Lever 544 may be biased to spring inwardly into proximal collar 542 upon suture 94 passing therethrough. During translation of the anchor in a first direction, suture 94 may be allowed to freely pass through proximal collar 542 and past lever 544 due to its pivoting motion. When the anchor is moved or urged in the reverse direction, lever 544 may act to cinch down upon suture 94 against an inner surface of proximal collar 542, as shown in the figure.

[0199] Another variation 546 of assembly 540 is shown in the cross-sectional view of Fig. 26B in which proximal collar 548 is shown as having at least two levers 550, 552 both biased in opposing directions to create a tortuous path for suture 94 to traverse. In either variation, the cinching levers may be configured to prevent or inhibit the over-cinching or cutting of suture 94. Figs. 26C and 26D show alternative end views of Fig. 26A. Uni-directional lever 544, as seen in Fig. 26C, may be formed from the side wall of proximal collar 542 such that when lever 544 cinches down upon suture 94, the corners or ends of lever 544 contact an inner surface of proximal collar 542 at contact points 554. The contact which occurs may ensure that an open space 556 is preserved and that lever 544 is prevented from over cinching onto suture 94 within space 556 and cutting suture 94. Fig. 26D shows an alternative uni-directional lever 544' which defines a curved or arcuate edge 558 which contacts suture 94. The arcuate edge 558 may prevent the over cinching onto suture 94 and cutting of suture 94.

[0200] Figs. 26E, 26F, and 26G show alternative variations of cinching assembly 546 with uni-directional levers having various configurations. Fig. 26E shows a cross-sectional side view of cinching assembly 560 in which proximal collar 562 may have levers 564, 566 directed and biased in opposing directions to create a tortuous path. Each of the levers 564, 566 in this variation may be curved inwardly towards proximal collar 562. Fig. 26F shows a cross-sectional side view of cinching assembly 568 in which proximal collar 570 has uni-directional levers 572, 574 angled towards on another when biased inwardly. And Fig. 26G shows a cross-sectional side view of cinching assembly 576 in which proximal collar 578 has

uni-directional levers **580**, **582** curved outwardly relative to one another when the levers are biased within collar **578**.

[0201] Figs. 27A and 27B shows yet another variation of cinching assembly **590** which utilizes a reconfigurable hollow member for cinching suture **94**. As shown in Fig. 27A, hollow member **594** may be constrained within tubular delivery member **592** to retain an elongate shape with suture **94** passing uninhibited therethrough. When the anchor is to be cinched, hollow member **594** may be advanced distally from tubular member **592** and when hollow member **594** has been ejected, it may adapted to reconfigure itself into a crimped configuration **594'** having a non-linear passageway. Suture **94** passing through the crimped configuration **594'** may be inhibited from passing freely therethrough by crimp **596** created within the hollow member. Hollow member **594** may have a variety of cross-sectional shapes, e.g., circular, rectangular, square, hexagonal, etc., and it is preferably made from a material having shape memory characteristics, e.g., Nitinol, such that when hollow member **594** is unconstrained, it may automatically reconfigure into its crimped configuration **594'**.

[0202] Another variation of cinching assembly **600** which is configured to reconfigure itself upon being unconstrained is shown in the cross-sectional views of Figs. 28A to 28C. In this variation shown in Fig. 28A, cinching collar **602** may comprise at least two circular members, first collar **606** and second collar **608**, connected by an elongate bridging member **604**. Cinching collar **602** may be positioned within launch tube **18** proximally adjacent to proximal collar **610** and adapted to reconfigure itself once released from launch tube **18** such that a tortuous path is created for suture **94**. Fig. 28B shows an alternative variation in the cinching collar which may be an integrated variation with the proximal collar such that first collar **606** is connected directly to the anchor via joining member **612**. In either variation, once the cinching collar has been ejected from launch tube **18**, the collar may configure itself such that first collar **606** and second collar **608** are biased towards one another to form, e.g., a "C"-shape as shown in Fig. 28C. The tortuous path which is created by cinching collar **602** for suture **94** to follow may be sufficient to prevent the further translation of the anchor relative to suture **94**. Figs. 28D and 28E, respectively, show perspective views of cinching collar **602** in a constrained delivery configuration and an unconstrained cinching configuration.

[0203] Fig. 28F shows a cross-sectional side view of another cinching assembly which is similar to the variation shown in Fig. 28B. Rather than having first collar **606** and joining

member 612 reconfigure itself into a semi-circular shape relative to the anchor, first collar 606 may reconfigure itself to maintain its orientation relative to the anchor while joining member 612 may be formed to curve appropriately or approximately in an "S"-type configuration. The reconfigured cinching member may act to lock suture 94 relative to the anchor when the anchor is moved in a reverse direction.

[0204] Another configuration for a cinching assembly is shown in the side view of Fig. 28G, which shows cinching member 616 located proximally of proximal collar 614. Cinching member 616 may be fabricated from a variety of materials, e.g., Nitinol, spring stainless steel, etc., which exhibit shape memory or superelastic characteristics, or aspects thereof. In use, cinching member 616 may be configured into an elongate delivery configuration. When the tissue anchor is to be cinched or locked relative to the tissue, cinching member 616 may be released from a constraining force such that cinching member 616 reconfigures itself into an expanded or extended configuration which creates a tortuous path for suture 94 which sufficiently locks suture 94 within cinching member 616.

[0205] Cinching member 616 may be comprised generally of an elongate bar, ribbon, cylinder, etc., or any elongate member having a diameter or cross-sectional area in its delivery configuration which is sufficiently small to be disposed and/or translated within launch tube 18. Cinching member 616 may define a plurality of openings 618 along the length of cinching member 616 such that when cinching member 616 is in its elongate delivery configuration, as shown in Fig. 28G, suture 94 may be interwoven through openings 618 along a relatively straightened path. Openings 618 may be located along cinching member 616 at uniform locations or they may be randomly positioned along the length of cinching member 616. When released, cinching member 616 may reconfigure itself into an expanded suture-locking configuration 616' which is sufficiently large to prohibit its passage into or through proximal collar 614, as shown in Fig. 28H. Expanded configuration 616' may comprise any reconfigured shape so long as the expanded shape is adapted to create the tortuous path for suture 94 and is large enough so that passage through proximal collar 614 is not possible.

[0206] Other cinching and locking mechanisms which utilize mechanical clamping or crimping to achieve locking of the suture within or through the anchors may also be used to facilitate uni-directional locking.

[0207] For instance, cinching assembly **620** may be seen in the cross-sectional view of Figs. 29A and 29B. Fig. 29A shows delivery tube member **622** having crimping collar **624** disposed therewithin proximally of anchor proximal collar **626**. Suture **94** may be passed through both crimping collar **624** and proximal collar **626**. Once the anchor has been desirably positioned, crimping collar **624** may be advanced distally adjacent to proximal collar **624** and mechanically crimped **624'** down upon suture **94** to create a lock and prevent the reverse movement of the anchor over suture **94**, as shown in Fig. 29B. The crimping may be accomplished via mechanical graspers or pinchers configured to clamp down upon collar **624**. Similarly, Fig. 30A shows cinching assembly **630** in which the crimping collar **632** may be integral with the anchor rather than being a separate member. Fig. 30B shows a mechanically crimped collar **632'** which eliminates the need for a separate collar.

[0208] To accomplish mechanical crimping upon a cinching collar, various methods may be utilized. Fig. 31A shows one variation of a tool assembly **640** which may be adapted to apply a mechanical crimping force upon a crimping collar. As seen, launch tube **18** may have delivery push tube **642** located therewithin and positioned proximally of proximal collar **652** of the tissue anchor. Push tube **642** may be used to hold and/or eject proximal collar **652** from launch tube **18**. Crimping device **644** may be advanced within launch tube **18** via crimping control member **646**, which may be manipulated from its proximal end.

[0209] A collar retaining channel **650** may be defined in a distal end of crimping device **644** and adapted to receive and securely hold proximal collar **652** within during a clamping or crimping process. Crimping members or arms **648** may be positioned within crimping device **644** on either side of retaining channel **650**. When proximal collar **652** or crimping sleeve is to be clamped or crimped, crimping members or arms **648** may be driven into contact with proximal collar **652** to crimp the collar. Moreover, crimping arms **648** may be actuated through a variety of methods, e.g., hydraulically, pneumatically, via mechanical leverage, etc.

[0210] An alternative crimping assembly **660** is shown in the cross-sectional view of Fig. 32A. Crimping device **662** may be seen within launch tube **18** extending from crimping control member **664**. Collar retaining channel **672** may be likewise defined within crimping device **662** for retaining proximal collar **670** during a crimping procedure. This variation may utilize a separate elongate crimping member **666** having actuatable crimping arms **668** positioned at a distal end of elongate member **666**. In use, with proximal anchor collar **670** positioned within retaining channel **672**, elongate member **666** may be advanced distally until

crimping arms **668** are positioned over proximal collar **670** and crimped down. Fig. 32B shows an exploded perspective view of the crimping assembly.

[0211] Figs. 31B to 31D show side, end, and perspective views, respectively, of one variation of an anchor proximal collar **652** which is adapted for crimping upon a suture passing therethrough. To facilitate crimping of the collar **652**, a circumferential slot **656** may be defined through collar **652** partially around its circumference. Another longitudinal slot **658** may be defined through collar **652** extending longitudinally from a proximal edge of collar **652** to circumferential slot **656**. These slots **656**, **658** may define at least two crimping arms **654** which may be crimped down upon a length of suture passing through collar **652**.

10 [0212] Aside from the crimping mechanisms described above, additional measures may be optionally implemented to facilitate the cinching or locking of an anchor. Other measures may also be taken to inhibit any damage from occurring to the suture routed through an anchor.

[0213] To ensure that the integrity of suture **94** is maintained in the presence of metallic basket anchors **682** and to ensure that suture **94** is not subjected to any nicks or cuts, the portion of suture **94** passing through basket anchor **682** may be encased in a protective sleeve **690**, as shown in the perspective view of Fig. 33A of anchor-sleeve assembly **680**. The basket anchor **682** is shown in this variation as having anchor struts or arms **688** in a partially deployed configuration. Sleeve **690** may extend between distal collar **684** and proximal collar **686** to prevent excessive contact between suture **94** and elements of basket anchor **682**. Fig. 33B shows an end view of the anchor-sleeve assembly **680** showing the relative positioning of sleeve **690** relative to suture **94** and anchor collar **686**. Sleeve **690** may be made from a variety of polymeric materials, e.g., polypropylene, PTFE, etc., provided that the material is suitably soft.

25 [0214] Fig. 34A shows a cross-sectional view of cinching assembly **700** which may be implemented with any of the cinching and locking mechanisms described above. This particular variation utilizes the partial cold-flowing of the engaged suture **94** to enhance the locking or cinching effect of the tissue anchor. The cinching collar, or in this variation proximal collar **702**, against which suture **94** is wedged may have multiple through-holes **704** defined over the surface of collar **702**. The cross-sectional side view shows suture **94** wedged within collar **702** against locking pin **338**. The portion of suture **94** which is adjacent to through-holes **704** may have regions which cold-flow partially into through-holes **704**, as

shown by cold-flowed suture material **706**. These portions of suture material **706** may enhance the locking aspects of suture **94** against collar **702**. Fig. 34B shows a perspective view of collar **702** with multiple through-holes **704** defined over the body of collar **702**. Through-holes **704** may be defined in a uniform pattern; alternatively, they may be randomly defined over collar **702** or only over portions of collar **702**.

[0215] Figs. 35A to 35E show an alternative variation **710** for locking a tissue anchor relative to suture **94**. An outer sleeve **720** which is preferably comprised of a polymeric material capable of at least partially flowing when heated, e.g., PTFE, may be disposed circumferentially about an electrically conductive inner sleeve **722**. As shown in the perspective views of Figs. 35B and 35C, inner sleeve **722** may be disposed within lumen **726** of outer sleeve **720**. Inner sleeve **722** may randomly or uniformly define a plurality of openings or through-holes **724** over the surface of inner sleeve **722**.

[0216] In operation, outer and inner sleeves **720**, **722**, respectively, may be positioned within delivery push tube **716** proximally of proximal collar **718** with suture **94** passing therethrough. When the tissue anchor has been desirably positioned and suture **94** has also been desirably tensioned, an induction unit **712** having one or more induction coils **714** therewithin may be positioned circumferentially (or at least partially circumferentially) about outer and inner sleeves **720**, **722**. Induction unit **712** may be configured to be disposed within the launch tube **18** or it may be configured to be advanced over or positioned upon launch tube **18**. Thermal energy or electrical energy in various forms, e.g., RF, microwave, etc., may be delivered to induction coils **714** such that the energy heats inner sleeve **722**, which may be positioned within induction coils **714**, as shown in Fig. 35A. As inner sleeve **722** is heated via induction, the inner surface of outer sleeve **720** may be partially melted or deformed such that the material flows at least partially through or within through-hole **724** and contacts suture **94** positioned within inner sleeve **722**. The flowed material may cool and act to lock outer and inner sleeves **720**, **722** onto suture **94**. Induction unit **712** may then be removed from the area leaving outer and inner sleeves **720**, **722** locked relative to the tissue anchor.

[0217] Although inner sleeve **722** shows through-holes **724** as circularly defined openings, other shapes may be utilized. For example, Fig. 35D shows a perspective view of one inner sleeve variation **728** having longitudinally defined slots **730**. Alternatively, Fig. 35E shows a perspective view of another inner sleeve variation **732** having circumferentially defined slots **734**. Any variety of opening shapes may be utilized so long as the opening or openings allow

for material from the outer sleeve 720 to flow through into contact with the suture positioned within.

[0218] Other configurations for the anchor itself may also be utilized in conjunction with any of the cinching apparatus described herein. For instance, the linear cinching member 616 shown in Figs. 28G and 28H may also be utilized to function as an anchor itself. Such a linear anchor may be fabricated from a metal, e.g., Nitinol, spring stainless steel, etc., which exhibit shape memory or superelastic characteristics, as described above.

[0219] Alternatively, an elongate linear anchor may be comprised of a flexible polymeric material such that the anchor remains in a linear configuration when disposed within a delivery tube for deployment. Examples of potential polymeric materials may include, e.g., polyethylene, polyester, polystyrene, polycarbonate, nylon, teflon, elastomers, etc. However, once the elongate anchor is ejected or deployed from the delivery tube, the anchor may be configured to compress longitudinally, i.e., along the length of the anchor, upon the application of a force in a longitudinal direction relative to the anchor such that portions of the linear anchor bow or expand in a radial direction. The anchors may be configured to bow or expand through a number of techniques such as heat-setting the material. Additional methods and variations are described below in further detail.

[0220] Fig. 36A shows a perspective view of one variation 740 of a linear anchor. In this variation, the linear anchor 740 may generally comprise an elongate ribbon or flattened wire 742 having at least one or more openings 744 defined through the anchor 740 along its length. Linear anchor 740 may generally range anywhere in length from, e.g., 3.50 to 7.25 inches, or greater. The thickness of linear anchor 740 may also range from, e.g., 0.010 to 0.020 inches, and is preferably 0.013 inches, while the width may range from, e.g., 0.030 to 0.065 inches, and is preferably 0.050 inches.

[0221] Ribbon 742 illustrates openings 744 in an optionally offset pattern relative to one another along the length to enhance the ribbon 740 twisting or bowing effect when compressed linearly. Alternatively, openings 744 may be linearly aligned along the length, if desired. Moreover, this variation illustrates openings 744 uniformly spaced apart from one another anywhere from, e.g., 0.375 to 0.750 inches, over the length of anchor 740. Alternatively, openings 744 may vary in diameter, e.g., 0.015 inches, so long as the length of suture being routed or interwoven through openings 744 is able to freely slide through openings 744.

[0222] One or both ends 748 of ribbon 742 may be optionally configured to be atraumatic by having a blunted end or a tapered end to reduce or inhibit damage to the surrounding tissue. The regions 746 of ribbon 742 located between openings 744 may be configured to flex in a predetermined orientation when anchor 740 is linearly compressed such that the compressed and expanded ribbon 742 expands in a predetermined orientation, as described further below.

[0223] Fig. 36B shows a perspective view of another variation 750 of ribbon 752 which is similar to variation 740 of Fig. 36A. Variation 750 defines a plurality of openings 754 which may be defined in a varied offset pattern, e.g., pairs of openings 754 may be offset relative to one another, as shown.

[0224] In order to ensure the collapse of the ribbon into a bowed or expanded pattern, the suture may be routed through each, or at least several, of the openings. Fig. 37A shows the ribbon 742 of Fig. 36A with suture 94 routed through each opening 744 in an alternating or interwoven pattern. Similarly, Fig. 37B shows the ribbon 752 of Fig. 36B with suture 94 routed through openings 754 likewise in an alternating or interwoven pattern. In either case, a terminal end of suture 94 may be formed into a knot 760 distally of the ribbon to prevent the passage of suture 94 proximally. This may be done to facilitate the collapse of the ribbon by simply pulling or tensioning suture 94 to collapse the ribbon upon itself. Rather than forming a knot 760, suture 94 may be attached to the ribbon through any variety of methods, e.g., suture 94 may be tied or welded to the ribbon, or it may simply be attached via an adhesive, etc. Accordingly, when the ribbon is compressed in a longitudinal direction relative to suture 94 by tensioning suture 94, the ribbon compresses into an expanded pattern while bending or folding along the regions in-between the openings.

[0225] Various methods may be utilized to facilitate the bending or folding of the ribbon anchor into desired expanded patterns. One variation may include an elongate ribbon 770 having alternating portions 772 of the ribbon material between the openings 744 notched out or removed, as shown in the variation of Fig. 38. Alternatively, Fig. 39 shows another variation in which the ribbon 780 may be formed to define undulations 782 such that an "S"-type ribbon pattern is fabricated.

[0226] Once the ribbon anchor is urged into its collapsed and deployed configuration, the ribbon anchor may be further configured to provide some degree of spring force which permits the anchor to absorb a range of deflections which may be imparted upon the anchor.

The ability of the ribbon anchor to absorb a range of deflections may allow the ribbon anchor to absorb some force which would otherwise be imparted to the underlying tissue surface.

[0227] Such a spring force may be imparted to the ribbon anchor in one variation as shown in Fig. 40A, which shows a perspective view of ribbon anchor **790** with suture **94** routed through the openings. Biasing elements, such as springs **792**, may be positioned along portions of ribbon anchor **790** with suture **94** routed therethrough. The variation shows two springs **792** positioned near either end of ribbon **790**; however, a single spring or multiple springs may be utilized depending upon the desired elastic spring effects of the ribbon anchor **790**. Moreover, the spring or springs **792** may be positioned at any position along the length of the ribbon anchor **790**; alternatively, one or more springs **792** may even be positioned proximally or distally of one or both ends of the ribbon anchor **790** rather than between the folds of the ribbon anchor **790**.

[0228] Fig. 40B shows a variation in ribbon anchor **790** which is similar to the assembly of Fig. 40A. This variation utilizes biased elements **794**, which may be fabricated from one of a variety of metallic or polymeric materials similar to or the same as the material of ribbon anchor **790**. Biased elements **794** may generally comprise angled members having suture **94** routed therethrough and which are biased to pivot about a hinge and retain its angled configuration.

[0229] In use, when suture **94** is tensioned or pulled relative to ribbon anchor **790**, ribbon anchor **790** may reconfigure itself into its compressed configuration. Fig. 40C shows a perspective view of the ribbon **790** of Fig. 40A which has been partially collapsed. As shown, springs **792** may be compressed between the portions of ribbon anchor **790** and function to provide a biasing force which allows the anchor assembly to absorb a range of deflections while isolating the force from the underlying tissue. Fig. 40D shows the partially compressed anchor ribbon **790** with the biased elements **794** from Fig. 40B. This variation of the anchor assembly may function similarly to that of the assembly of Fig. 40C.

[0230] An alternative variation of the ribbon anchor is shown in the perspective view of Fig. 41. Rather than utilizing a ribbon or flattened wire, this variation utilizes a tubular member **800** with suture **94** routed through a plurality of openings defined along its length. The tubular member **800** may be fabricated from any of the materials as described above, and because of its circular cross-section, it may provide some spring force as tubular member **800**

is collapsed upon itself. Other alternatives may also utilize elongate members having elliptical, rectangular, triangular, etc., cross-sections.

[0231] Fig. 42 shows a perspective view of tubular member **810** having a partial cut-out **812** along the length of tubular member **810**. A single cut-out may be utilized to provide for a bending portion. Alternatively, multiple cut-outs **822** may be formed in a tubular member **820**, as shown in Fig. 43. Multiple cut-outs **822** may be formed along a single side of tubular member **820**, or they may be alternated on opposing sides, as shown in the figure. In either case, suture **94** may be routed in an alternating pattern along the lengths of the tubular members to facilitate the bending or folding of the members, as described above.

[0232] Another alternative ribbon anchor **830** is shown in Fig. 44, which illustrates multiple individual lengths of elements **832** encased (or at least partially encased) in a coating or covering **836**. Each or a number of the elements **832** may be fabricated from a variety of materials, e.g., metals such as Titanium, stainless steel, Nitinol, etc., or plastics, etc., and the coating or covering **836** may be made from a variety of flexible polymeric or elastomeric materials. The length of the coating or covering **836** extending between each of the elements **832** may function as living hinges **834** while suture **94** may be routed through each or several of the elements **832**. When ribbon anchor **830** is compressed, it may fold along the living hinges **834** as described above.

[0233] Fig. 45 shows yet another alternative in which ribbon anchor **840** may be comprised of one or more lengths of wire **842** covered or coated with the same or similar material as coating or covering **836** above. Wires **842** may be fabricated from the same or similar material as elements **832** above. Similarly, suture **94** may be routed through a plurality of openings defined along the length of ribbon anchor **840**.

[0234] Fig. 46 shows yet another variation of ribbon anchor **850** which is similar to the ribbon anchors described above, yet this variation may have a length which has a non-uniform thickness. For instance, ribbon anchor **850** may have one or more regions **852** which are notched out or thinned relative to the rest of the length of ribbon anchor **850**. The thicknesses of the notched or thinned regions **852** may be varied to alter the bending or folding characteristics of ribbon anchor **850**, as desired.

[0235] Fig. 47A shows yet another variation in which a length of wire **860** may simply be utilized to fold or flatten in an expanded pattern. Wire **860** may be extruded from various materials, e.g., stainless steel, Nitinol, Titanium, plastic, etc., and it may be further configured

to have shape memory characteristics such that when collapsed, wire **860** folds or collapses into a predetermined pattern. Wire **860** may also comprise one or more eyelets **862** along its length through which suture **94** may be routed. Eyelets **862** may be welded or adhered to wire **860** through any number of fastening methods. Another alternative is shown in Fig. 5 47B, which is similar to the variation of Fig. 47A. In this variation, a single wire **860'**, similar to above, may be configured to define a plurality of loops **862'** rather than having separate eyelets attached thereto. Suture **94** may be routed through these formed loops **862'**.

[0236] Alternatively, a length of wire **870** may be utilized without suture. Fig. 48 shows an example in which wire or ribbon **870** may be comprised of a shape memory alloy, such as 10 Nitinol, which is configured to form a tangled portion **872** of wire **870** when unconstrained, similar to a "bird's nest". This tangled portion **872** may simply expand into an intertwined mass of wire, which prevents its passage through a tissue fold **F**.

[0237] In operation for any of the ribbon anchors described above, one or more ribbon anchors may be utilized. For instance, a first anchor may be positioned distally of a tissue 15 fold **F** and a second anchor may be positioned proximally of the same tissue fold **F**, as shown in Fig. 49A. The distal portion of suture **94**, which extends between the two anchors, may be anchored to the first anchor via, e.g., fastener or knot **760**. As suture **94** is tensioned or pulled, each of the ribbon anchors **742** may be compressed and collapse into an expanded configuration against the tissue fold **F**. A locking mechanism **880**, which may comprise any 20 of the locking mechanisms described above, may be proximally positioned over suture **94** and cinched against the ribbon anchor **742** to thereby lock each of the ribbon anchors **742** into their collapsed and expanded configurations, as shown in Fig. 49B. Although this example illustrates the use of ribbon anchors **742**, any of the linear anchors described above may be utilized either alone or in combination with any other linear anchor or other anchor described 25 above.

[0238] As mentioned above, the ribbon anchor may be collapsed into an expanded configuration against the tissue surface. Accordingly, the ribbon anchor may be configured to collapse in a variety of bowed or expanded configurations such that the contact area of the anchor against the tissue surface is increased, if so desired. Fig. 50A shows a top view of one 30 variation of a ribbon anchor **890** which is configured simply to fold linearly upon itself to form arms **892**.

[0239] Fig. 50B shows a top view of another variation **894** in which the ribbon anchor may be configured to form a crossing pattern with at least four arms **896**. And Fig. 50C shows a top view of yet another ribbon anchor **898** where multiple arms **900** may be formed in a radial pattern to facilitate the distribution of the anchor against the tissue surface.

5 [0240] Alternatively, the ribbon anchor may be configured to form a number of secondary support arms **904**, as shown in the bowtie-like configuration of variation **902** in Fig. 50D. Fig. 50E shows another variation **906** where a square configuration may be formed via multiple support arms **908** formed by the collapsing anchor. Fig. 50F shows yet another variation **910** where a single support arm **912** may be formed by the collapsing anchor structure. Any number of patterns and folded arms may be formed depending upon the
10 desired configuration and aspects of the collapsed ribbon anchor.

[0241] Referring now to Figs. 51, a variation of methods and apparatus for grasping a suture and cinching and/or locking an anchor (e.g., actuating a cinching or locking feature or mechanism of the anchor) is described. Apparatus **1000** illustratively comprises tube **1010**
15 having lumen **1011** with distal outlet or opening **1012**, as well as resilient member **1020** that is biased to obstruct at least a portion of distal outlet **1012**. Resilient member **1020** may be proximally coupled to tube **1010** at attachment **1021**, such that the resilient member acts as a cantilevered beam having distal obstruction **1022** that is biased to at least partially obstruct the outlet of lumen **1011**.

20 [0242] As seen in Fig. 51A, grasper **1050** may be advanced coaxially through the lumen of tube **1010**, such that the grasper applies a bending moment to resilient member **1020** that reversibly displaces obstruction **1022** and opens up the distal outlet of lumen **1011**. Grasper **1050** extends beyond distal outlet **1012** of tube **1010**, and reversibly engages, e.g., suture **94** coupled to distal anchor **306** and proximal anchor **318** disposed across tissue fold **44**. The
25 anchors illustratively comprise cinching mechanism **316** having cinching collet **326** that may be friction fit within anchor collar **322**, thereby locking anchor **318** in the deployed configuration. As will be apparent, alternative anchor assemblies and/or cinching mechanisms may be used in combination with apparatus **1000**.

[0243] In Fig. 51B, grasper **1050** and engaged suture **94** are retracted relative to tube **1010**
30 and anchors **306**, **318**. Once the grasper is disposed proximal of outlet **1012** of lumen **1011** of tube **1010**, member **1020** resiliently returns to its unstressed configuration, whereby obstruction **1022** at least partially obstructs lumen outlet **1012**. Upon continued proximal

retraction of the grasper and suture, cinching collet **326** abuts obstruction **1022**, such that the collet is advanced distally relative to suture **94**.

[0244] As seen in Fig. 51C, the grasper may be retracted until collet **326** engages anchor collar **322** and cinches/locks anchor **318** in the deployed configuration. Grasper **1050** then
5 may disengage suture **94**, thereby completing deployment of the anchor assembly. As seen in Fig. 51D, apparatus **1000** may be removed from the patient to complete the procedure.

[0245] Tube **1010** optionally may comprise a variation of previously described launch tube **18**, and may be used in combination with tissue manipulation assembly **14**. For example, upon placement of an anchor assembly across tissue fold **44**, needle assembly **48** may be
10 removed from the modified launch tube, and grasper **1050** may be advanced therethrough to cinch/lock the anchor assembly. Alternatively, apparatus **1000** may comprise stand-alone apparatus positioned independently of tissue manipulation assembly **14**. In such a configuration, the apparatus may be used alone or in combination with assembly **14**.

[0246] Referring now to Figs. 52, another variation of methods and apparatus for grasping
15 a suture and cinching and/or locking an anchor (e.g., actuating a cinching or locking feature or mechanism of the anchor) is described. As with apparatus **1000** of Figs. 51, apparatus **1100** illustratively is described in conjunction with the cinching and locking of anchor **318** via suture **94** connected to cinching mechanism **316**. However, alternative anchor assemblies and/or cinching mechanisms may be used in combination with apparatus **1100**.

[0247] Apparatus **1100** comprises snare device **1110** having resilient wire loop **1112** and
20 resilient latch **1114**. Loop **1112** and latch **1114** may, for example, be fabricated from Nitinol. Snare device **1110** is configured for advancement through lumen **1201** of tube **1200** (which may, for example, comprise previously described launch tube **18**) in a collapsed delivery configuration. As seen in Fig. 52A, loop **1112** and latch **1114** may resiliently self-expand
25 upon advancement past distal outlet **1202** of tube **1200**, such that the latch and loop form an opened 'mouth' in which suture **94** may be captured.

[0248] In Fig. 52B, upon placement of suture **94** in the open space between latch **1114** and
loop **1112**, snare device **1110** may be retracted relative to tube **1200**, such that the tube urges
latch **1114** down into loop **1112**, thereby closing the 'mouth' of the snare device and
30 reversibly capturing the suture therein. In Fig. 52C, continued retraction of the snare device (and thereby suture **94**) relative to tube **1200** and anchor **318** may cause cinching collet **326** of cinching mechanism **316** to abut tube **1200**, such that the collet is advanced relative to

suture **94** and is friction fit within anchor collar **322** thereby locking anchor **318** in the deployed configuration. As seen in Fig. 52D, apparatus **1100** then may be removed from the patient to complete the procedure.

[0249] With reference to Figs. 53, a variation of the apparatus and method of Figs. 52 is described. Snare device **1110'** of apparatus **1100** comprises resilient wire loop **1112**, but does not comprise a resilient latch (such as latch **1114** of apparatus **1100** of Figs. 52) that coacts with the wire loop. Rather, suture **94** comprises proximal knot **K** that may be used in conjunction with snare device **1110'** and cinching mechanism **C** (e.g., cinching mechanism **316**) to cinch and secure anchors **A₁** and **A₂** (e.g., anchors **306** and **318**). As will be apparent, alternative or additional proximal protrusions other than knot **K** may be provided along suture **94**, such as a bead.

[0250] As seen in Fig. 53A, resilient wire loop **1112**, disposed in an expanded configuration distal of outlet **1202** of tube **1200**, may be advanced over suture **94** and knot **K**. Loop **1112** then may be retracted proximally within lumen **1201** of tube **1200**, as in Fig. 53B, which collapses the loop to a lower profile and captures suture **94** within the collapsed loop via knot **K**. In Fig. 53C, continued retraction of the loop relative to the tube retracts suture **94**, which causes cinching mechanism **C** to abut against distal outlet **1202** of tube **1200**, thereby cinching and securing anchors **A₁** and **A₂**.

[0251] As seen in Fig. 53D, once cinching is complete, wire loop **1112** may be re-advanced relative to tube **1200**, which causes the loop to resiliently expand, e.g., for release of suture **94** and knot **K**. The loop and the tube may be concurrently retracted relative to the suture to cause the suture to slip out of the wire loop. The grasping and cinching procedure may be repeated at additional locations of tissue anchoring, as desired.

[0252] Referring to Figs. 54, a method of using the variation of apparatus **1100** of Figs. 53 in combination with tissue manipulation assembly **14** of tissue plication assembly **10** is described. As seen in Fig. 54A, tube **1200** of apparatus **1100** may comprise launch tube **18** of assembly **14**, and resilient wire loop **1112** of snare device **1110'** may be advanced through tube **18**. As seen in Fig. 54B, the position of loop **1112** relative to assembly **14** may be controlled through articulation of tube **18** relative to the assembly, as well as advancement or retraction of the loop relative to the tube.

[0253] With reference to Fig. 55, a variation of the apparatus and method of Figs. 53 is described. In Fig. 55, resilient wire loop **1112'** of snare device **1110'** of apparatus **1100**

comprises a bent or cast profile having 'out-of-plane' geometry. Loop **1112'** may, for example, be heat-set with the desired profile. As illustrated, the loop's out-of-plane geometry may facilitate advancement of loop **1112'** against tissue **T** and/or over suture **94** and knot **K**.

[0254] Referring now to Figs. 56, additional variations of apparatus **1100** are described. In Fig. 56A, snare device **1110''** comprises multiple resilient wire loops **1112** disposed at angles to one another. In Fig. 56B, the multiple loops are connected together at distal connection **1113**. Providing multiple loops may simplify engagement of suture by giving the snare device additional elements for initiating such engagement.

[0255] With reference to Figs. 57, another variation of the apparatus and methods of Figs. 52 is described. As seen Fig. 57A, apparatus **1100** comprises snare device **1110'''** having loop or eyelet **1112** and latch **1114** that are integrated into a single device. Latch **1114** is pivotably connected to the elongated shaft of loop **1112**. A medical practitioner may pivot the latch relative to the loop via a control wire or other element that extends proximally for manipulation. Alternatively, the latch may be resilient, as described previously, and may be pivoted by advancing tube **1200** against the latch.

[0256] Figs. 57B and 57C provide side-sections through loop **1112** illustrating engagement of suture **94** with snare device **1110'''**. As seen in Fig. 57B, latch **1114** initially is disposed 'above' loop **1112**. The latch then may be pivoted within the loop to reversibly engage the suture, as in Fig. 57C, as well as in Fig. 57A.

[0257] Referring now to Figs. 58, a variation of apparatus **1000** of Figs. 51 is described, as well as a method of using the apparatus to cinch an anchor assembly. In Figs. 58, apparatus **1000** illustratively comprises tube **1010'** having lumen **1011** with distal outlet or opening **1012**, as well as slot **1014** disposed proximal of opening **1012**. Resilient member **1020** having distal obstruction **1022** is proximally coupled to tube **1010'** at attachment **1021**. The resilient member acts as a cantilevered beam with obstruction **1022** biased to pass through slot **1014** and obstruct at least a portion of lumen **1011**, as in the front view of Fig. 58A and the side view of Fig. 58B. Passing obstruction **1022** through slot **1014** may reduce a risk of inadvertently snagging obstruction **1022** on, e.g., tissue or suture, as compared to the configuration of obstruction **1022** in the variation of Figs. 51. Furthermore cinching of an anchor assembly may be performed within the distal region of tube **1010'**, thereby providing lateral support during such cinching.

[0258] As seen in Fig. 58C, grasper **1050** may be advanced coaxially through the lumen of tube **1010'**, such that the grasper applies a bending moment to resilient member **1020** that reversibly displaces obstruction **1022**. Obstruction **1022** is pushed through slot **1014** and out of lumen **1011**, thereby opening up the lumen. Grasper **1050** extends beyond distal outlet **1012** of tube **1010'**, e.g., for reversibly engaging suture **94** to approximate and secure anchors **A₁** and **A₂** via previously described cinching mechanism **C**. In Fig. 58D, grasper **1050** is retracted within lumen **1011** of tube **1010'** proximal of slot **1014**. Obstruction **1022** resiliently resumes its obstructing position through the slot within lumen **1011**. Continued retraction of grasper **1050** abuts cinch mechanism **C** against obstruction **1022** for cinching anchors **A₁** and **A₂**, as described previously.

[0259] With reference to Figs. 59, another variation of apparatus and a method for grasping and cinching a tissue anchor are described. Apparatus **1300** comprises tube **1310** having lumen **1311**, collet **1312** and endcap **1314**. Collet **1312** obstructs the distal outlet of lumen **1311**. Endcap **1314**, which comprises central opening **1315**, maintains collet **1312** within tube **1310**.

[0260] As seen in Fig. 59A, grasper **1050** may be advanced through lumen **1311** of tube **1310**. As the grasper is advanced against collet **1312**, it urges the collet open, thereby allowing the grasper to extend past the collet, as in Fig. 59B. Grasper **1050** then may engage suture **94** proximal of cinch mechanism **C**, and may be retracted back within lumen **1311** of tube **1310**. Once the grasper has been retracted proximal of collet **1312**, the collet dynamically closes and again obstructs the distal outlet of lumen **1311**. Continued retraction of grasper **1050** abuts cinch mechanism **C** against collet **1312** for cinching of anchors **A₁** and **A₂**, as in Fig. 59C.

[0261] Referring now to Figs. 60, another variation of apparatus **1000** of Figs. 51 and 58 is described. In Figs. 60, apparatus **1000** illustratively comprises distal tubular segment **1010''** having lumen **1011** (shown in Fig. 60D) with distal outlet or opening **1012**, as well as a plurality of slots **1014** (also shown in Fig. 60D) disposed proximal of opening **1012**. A plurality of resilient members **1020**, each having a distal obstruction **1022**, is proximally coupled to tube **1010''**, e.g., at attachments **1021'**. Although apparatus **1000** illustratively comprises three slots **1014** and three resilient members **1020** in the variation of Figs. 60, it should be understood that any alternative number of slots may be provided as desired. The plurality of slots and resilient members preferably are symmetrically disposed about the

circumference of tubular segment **1010''**, as seen in the end view of Fig. 60B, as well as longitudinally aligned, as seen in Figs. 60C and 60D.

[0262] Overtube **1026** illustratively is concentrically disposed over tubular segment **1010''** and extends from the proximal region of apparatus **1000** to attachments **1021'** for attaching
5 resilient members **1020** to the tubular segment, as described hereinafter. Optional proximal handle **1018** is coupled to a proximal region of overtube **1026** to facilitate grasping apparatus **1000**. Lumen **1011** of tubular segment **1010''** may extend through overtube **1026** and handle **1018**. Furthermore, overtube **1026** may be formed into a straightened rigid body suitable for insertion within a body percutaneously, e.g., laparoscopically. Alternatively, overtube **1026**
10 may be formed into a flexible body, at least partially along its length or over its entire length, such that the overtube **1026** may be advanced endoluminally, e.g., directly through a patient's esophagus or through an endoscopic device.

[0263] As best seen in Figs. 60C and 60D, members **1020** may, for example, be integrally formed with tubular segment **1010''**, or may be attached in a manner that provides the tubular
15 segment with a substantially continuous or smooth delivery profile. To achieve a smooth profile, proximal slots **1016** may be formed within tubular segment **1010''**, and proximal extensions **1024** of resilient members **1020** may be positioned within the proximal slots. Overtube **1026** then may be positioned over the proximal extensions of the resilient members (though not over the length of the members), such that the overtube interference fits or locks
20 proximal extensions **1024** of the resilient members within proximal slots **1016** of tubular segment **1010''**.

[0264] Resilient members **1020** act as cantilevered beams with obstructions **1022** biased to pass through slots **1014** and obstruct at least a portion of lumen **1011**, as seen in Figs. 60B and 60D. Passing obstructions **1022** through slots **1014** may reduce a risk of inadvertently
25 snagging the obstructions on, e.g., tissue or suture, as compared to the configuration of obstruction **1022** in the variation of Figs. 51. A grasper or other tool may be advanced coaxially through lumen **1011** of apparatus **1000**, such that the grasper applies a bending moment to resilient members **1020** that reversibly displaces obstructions **1022**, as in Fig. 60C. Obstructions **1022** are pushed through slots **1014** and out of lumen **1011**, thereby opening up
30 the lumen. Obstructions **1022** resiliently resume their obstructing positions through slots **1014** within lumen **1011** upon retraction of the grasper proximal of the slots, as in Fig. 60B. The obstructions may, for example, comprise surface profiles having inclined planes or

wedges that act as one-way valves and facilitate displacement of the obstructions via distally-directed forces, but not via proximally-directed forces.

[0265] In the variation of apparatus 1000 illustrated in Figs. 60, slots 1014 and obstructions 1022 are disposed more proximal of distal opening 1012 than is slot 1014 in the variation of the apparatus illustrated previously in Figs. 58. This more proximal positioning of the slots and resilient members forms distal compartment 1013 disposed between distal opening 1012 and slots 1014 (i.e. between the distal opening and obstructions 1022 disposed through slots 1014). As previously-described cinch mechanism C is abutted against obstructions 1022 during cinching, the cinch mechanism may pass through distal opening 1012 of tubular segment 1010'' and be at least partially disposed within distal compartment 1013, as shown in Fig. 60E. It is expected that this will enhance lateral stabilization of cinch mechanism C relative to tubular segment 1010'' and obstructions 1022 during cinching. Such enhanced lateral stabilization may reduce a risk of shearing suture 94 against a torqued or rotated crimp mechanism C during cinching. Moreover, to further reduce any risks of shearing suture 94 during cinching, the inner edges R of distal compartment 1013 may be radiused or chamfered to provide a smooth surface or transition for suture 94 to slide over or to contact against during cinching.

[0266] Referring now to Figs. 61, it may be desirable to provide a medical practitioner with feedback as to a degree of force applied to an anchor assembly, for example, to reduce a risk of anchor assembly failure or of failure of the cinching apparatus. Figs. 61 illustrate a variation of the apparatus and method of Figs. 60 comprising a force feedback mechanism for controlling and/or monitoring cinching forces applied to an anchor assembly. In the variation of Figs. 61, overtube 1026' of apparatus 1000 comprises section 1027 that extends proximally of optional proximal slider 1060, which is described hereinafter. Force feedback handle 1030 having lumen 1031, tubular shaft 1032 and handle member 1034 is coaxially disposed over section 1027 of overtube 1026'.

[0267] As seen in Fig. 61C, handle 1030 and overtube 1026' form enclosed internal chamber 1036 within lumen 1031, which is radially disposed between shaft 1032 of the handle and section 1027 of the overtube, and is axially disposed between handle member 1034 and overtube protrusion 1028. Overtube protrusion 1028 is coupled to section 1027 of overtube 1026' and is configured to translate within chamber 1036, thereby altering a length of the enclosed chamber. Overtube 1026' further comprises proximal widening 1029

positioned at or near the proximal end of section 1027 that is configured to interact with narrowing 1038 of handle member 1034 to limit distal movement of the overtube relative to the handle.

5 [0268] Compression spring 1040 is disposed within chamber 1036, such that proximal translation/retraction of protrusion 1028 and overtube 1026' relative to handle 1030 compresses the spring, as seen in Fig. 61C. When compressed, the spring applies a restoring force to the protrusion and the overtube, as defined by the formula $F = -kx$, where F defines the restoring force vector, k is the spring constant of compression spring 1040 and x is the distance over which the spring has been compressed. The negative sign in the equation
10 denotes that the restoring force is in opposition to the direction of spring compression; in the variation of Figs. 61, this means that the restoring force is directed distally. The restoring force increases as the distance x over which the spring has been compressed increases. Additionally, the magnitude of the restoring force at a given level of compression may be controlled as desired, e.g., by specifying the spring constant k .

15 [0269] In cinching an anchor, handle 1030 may, for example, be held stationary (or advanced distally), while a previously described grasper, such as grasper 1050, is retracted proximally through the lumen of overtube 1026' with, e.g., engaged suture 94. This positions cinch mechanism C within distal compartment 1013 of apparatus 1000, as described previously. Continued retraction of the grasper cinches the anchor assembly via interaction
20 with resilient members 1020.

[0270] When the anchor assembly is fully cinched, cinch mechanism C abuts the tissue anchor(s), which increases resistance to further retraction of the grasper relative to overtube 1026'. Such increased resistance applies a force to resilient members 1020, which is transmitted along overtube 1026' to proximal handle 1030. This force proximally retracts the
25 overtube relative to the handle and compresses spring 1040 within chamber 1036 via interaction between the spring and the overtube's proximal stop 1028. Such compression provides the medical practitioner with force feedback indicating that the anchor assembly is fully cinched. The magnitude of this feedback increases as the grasper is further retracted.

[0271] Optional proximal slider 1060, which is configured to translate along overtube
30 1026', may be provided to measure and record a maximum cinching force applied to the anchor. As illustrated in Figs. 61C and 61D, the slider comprises O-ring 1062 that engages overtube 1026' and induces sufficient friction between the O-ring and the overtube to

maintain a position of the slider relative to the overtube when translational forces aren't actively applied to the slider. Optional indicia **1064** (as shown in Fig. 61B) are provided along the exterior of overtube **1026'** to indirectly measure a magnitude of cinching forces applied to the anchor assembly. As seen in Figs. 61A-61C, slider **1060** is positioned at a position along the indicia indicative of a minimum level of force application that the medical practitioner may desire to record. This minimum level may be greater than or equal to zero force.

[0272] In use, after the anchor assembly has been fully cinched and the cinch mechanism abuts the tissue anchor(s), the medical practitioner may continue to retract the grasper relative to the anchor assembly, as described previously. This compresses spring **1040** and provides force feedback to the medical practitioner. Shaft **1032** of handle **1030** moves from the position seen in Figs. 61A-61C to the position seen in Fig. 61D, whereat the shaft abuts slider **1060** at the minimum level of desired force measurement. It should be understood that, when this minimum level of desired force measurement is approximately zero force, the shaft may abut the slider in an at-rest configuration prior to cinching.

[0273] With shaft **1032** abutting slider **1060**, additional cinching force application by the medical practitioner further compresses spring **1040** and further advances handle **1030** relative to overtube **1026'**, which advances slider **1060** along the overtube and along indicia **1064**. After completion of cinching, the medical practitioner releases the anchor assembly, and the restoring force applied by spring **1040** decompresses the spring, which returns handle **1030** and overtube **1026'** to their initial at-rest positions relative to one another. However, slider **1060** maintains its position of maximum advancement, and a maximum degree of cinching force application then may be determined by recording the position of the slider relative to indicia **1064** and/or to overtube **1026'**.

[0274] It should be understood that as an alternative or in addition to force measurement, indicia **1064** may indicate a degree of slider or handle displacement, a magnitude of stress applied to the anchor assembly, or any other desired parameter. Furthermore, indicia **1064** may comprise a color-coded, numeric, etc., probability scale along the exterior of overtube **1026'** that indicates a probability of failure of the anchor assembly or cinching apparatus at a given level of cinching.

[0275] Referring now to Figs. 62, an off-axis variation of the force feedback cinching apparatus and method of Figs. 61 is described that reduces a required axial length for a tissue

grasper or other tool utilized in conjunction with the apparatus. In Figs. 62, apparatus 1000 comprises off-axis force feedback handle 1070 coupled to the proximal region of overtube 1026 along an axially-aligned segment of off-axis member 1072. The axially-aligned segment of member 1072 comprises through-hole 1073 that provides access to lumen 1011 of overtube 1026, e.g., for advancing a grasper therethrough to cinch an anchor assembly.

[0276] Tube 1074 extends proximally from the off-axis segment of member 1072, and tubular shaft 1076 is coaxially disposed over tube 1074. Handle member 1078 is coupled to the proximal end of shaft 1076, thereby forming enclosed chamber 1080 between off-axis member 1072, tube 1074, shaft 1076 and handle member 1078 (as shown in Figs. 62C and 62D). Shaft 1076 is configured to translate along the exterior of tube 1074, which alters the length of chamber 1080. As seen in Fig. 62C, the shaft comprises distal narrowing 1077 that interacts with proximal widening 1075 of the tube to limit proximal retraction of the shaft relative to the tube. Compression spring 1040 is disposed within chamber 1080, while slider 1060, as well as indicia 1064, optionally are disposed about the exterior of tube 1074.

[0277] The variation of apparatus 1000 of Figs. 62 may be utilized in a fashion similar to that described previously with respect to Figs. 61. A medical practitioner may grasp the apparatus along handle member 1078, which may be held stationary while a grasper, *per se* known, is advanced through through-hole 1073 of member 1072 and through the lumen of overtube 1026. The suture of an anchor assembly may be engaged with the grasper, and the grasper then may be retracted relative to apparatus 1000, in order to cinch the anchor assembly. This positions the anchor assembly's cinch mechanism within distal compartment 1013 of apparatus 1000, as described previously. Continued retraction of the grasper cinches the anchor assembly via interaction between the cinch mechanism and resilient members 1020 of apparatus 1000.

[0278] When the anchor assembly is fully cinched, the cinch mechanism abuts the tissue anchor(s), which increases resistance to further retraction of the grasper relative to overtube 1026. Such increased resistance applies a force to resilient members 1020 that is transmitted along overtube 1026 to off-axis force feedback handle 1070. This force distally advances handle member 1078 and shaft 1076 relative to tube 1074 and off-axis member 1072, thereby reducing the length of chamber 1080 and compressing spring 1040 therein. Such compression provides the medical practitioner with force feedback indicating that the anchor assembly is fully cinched. The magnitude of this feedback increases as the medical

practitioner increases the cinching force. The variation of apparatus **1000** of FIGS. 62 moves the force feedback mechanism off the central axis of the apparatus, which decreases a required length for the tissue grasper or other tool used in combination with the apparatus by decreasing the length of overtube **1026** and lumen **1011**.

5 [0279] If optional slider **1060** is utilized, as shaft **1076** moves from the position seen in Figs. 62A-62C to the position seen in Fig. 62D, the shaft abuts the slider at the minimum level of desired force measurement. Additional cinching force application by the medical practitioner further compresses spring **1040** and further advances shaft **1076** relative to tube **1074**, which advances slider **1060** along the tube and along optional indicia **1064**. After
10 completion of cinching, when the medical practitioner releases the anchor assembly and the restoring force applied by spring **1040** decompresses the spring to return handle **1070** to its initial at-rest position, slider **1060** maintains its position of maximum advancement, and a maximum degree of cinching force application then may be determined by recording the position of the slider relative to indicia **1064** and/or tube **1074**.

15 [0280] Although a number of illustrative variations are described above, it will be apparent to those skilled in the art that various changes and modifications may be made thereto without departing from the scope of the invention. Moreover, although specific locking or cinching configurations may be shown with various types of anchors, it is intended that the various locking or cinching configurations be utilized with the various types of anchors in
20 various combinations as practicable. Likewise, although specific apparatus for grasping and cinching anchors may be shown with specific types of anchors and/or locking or cinching configurations, it is intended that the various apparatus and methods for grasping and cinching anchors be used with the various anchors and the various locking or cinching configurations in various combinations as practicable. For example, although feedback
25 mechanisms and cinching monitors illustratively have been described in combination with grasp and cinch apparatus comprising reversible lumen obstructions, it should be understood that such apparatus alternatively may be used in combination with grasp and cinch apparatus comprising snares, or any other grasp and cinch apparatus (or any other type of apparatus) as desired. It is intended in the appended claims to cover all such changes and modifications
30 that fall within the true spirit and scope of the invention.

WHAT IS CLAIMED IS:

- 1 1. An apparatus for securing a tissue anchor, the apparatus comprising:
2 a tubular member defining a lumen therethrough with a distal outlet; and
3 at least one resilient member that at least partially obstructs the lumen
4 proximal of the distal outlet such that a distal compartment within the tube is defined between
5 the at least one obstructing resilient member and the distal outlet, wherein the obstructing
6 resilient member is adapted to be reversibly displaced from the lumen when displaced by a
7 grasper.
- 1 2. The apparatus of claim 1, further comprising a grasper configured for
2 coaxial advancement through the lumen, wherein the grasper is configured to extend beyond
3 the distal outlet of the lumen to grasp the tissue anchor or a portion thereof.
- 1 3. The apparatus of claim 1, wherein the tubular member is rigid.
- 1 4. The apparatus of claim 1, wherein the tubular member is flexible along
2 at least a portion of its length.
- 1 5. The apparatus of claim 1, wherein the apparatus is configured to cinch
2 the tissue anchor with the at least one resilient member.
- 1 6. The apparatus of claim 1, further comprising a cinching mechanism
2 adapted to cinch the tissue anchor when the anchor is urged against the at least one resilient
3 member.
- 1 7. The apparatus of claim 6, wherein the distal compartment within the
2 tubular member is adapted to at least partially receive the cinching mechanism therein during
3 cinching of the tissue anchor such that the cinching mechanism is laterally stabilized relative
4 to the tubular member.
- 1 8. The apparatus of claim 1, wherein the tubular member defines at least
2 one slot in communication with the lumen and wherein the at least one resilient member is
3 disposed within the at least one slot to at least partially obstruct the lumen.
- 1 9. The apparatus of claim 1, wherein the distal outlet defines an
2 atraumatic inner circumferential edge.

1 10. The apparatus of claim 1, further comprising a feedback element
2 configured to indicate a degree of anchor cinching.

1 11. The apparatus of claim 10, wherein the feedback element comprises a
2 spring element.

1 12. The apparatus of claim 10, further comprising a longitudinally
2 translatable marker positioned along the tubular member for visually indicating a degree of
3 anchor cinching.

1 13. The apparatus of claim 1, wherein the apparatus comprises three
2 obstructing resilient members positioned uniformly and circumferentially within the tubular
3 member.

1 14. The apparatus of claim 1, wherein the at least one obstructing resilient
2 member projects radially from the lumen when displaced.

1 15. A method for grasping and cinching a tissue anchor, the method
2 comprising:
3 deploying at least one tissue anchor and a cinching mechanism into or against a
4 region of tissue to be secured;
5 advancing a grasper through a lumen of a tubular member having at least one
6 resilient member that obstructs the lumen such that the grasper reversibly displaces the at
7 least one resilient member from the lumen;
8 grasping an element of the tissue anchor with the grasper; and
9 retracting the grasper and the tissue anchor element within the lumen of the
10 tubular member such that the at least one resilient member re-obstructs the lumen and the
11 cinching mechanism is laterally stabilized at least partially within the tubular member and
12 abutted against the obstructing resilient member.

1 16. The method of claim 15, further comprising cinching the anchor by
2 retracting the tissue anchor element while the cinching mechanism abuts against the at least
3 one resilient member.

1 17. The method of claim 15, wherein deploying at least one tissue anchor
2 comprises deploying into or against gastrointestinal tissue.

1 18. The method of claim 15, wherein grasping an element of the tissue
2 anchor comprises grasping a suture attached to or passing through the tissue anchor.

1 19. The method of claim 15, further comprising locking the tissue anchor
2 in a deployed configuration via the cinching mechanism.

1 20. The method of claim 15, wherein retracting the grasper comprises
2 drawing the cinching mechanism at least partially through a distal opening of the lumen such
3 that the cinching mechanism is abutted against the obstructing resilient member.

1 21. The method of claim 15, further comprising monitoring a cinching
2 force while retracting the grasper via a feedback mechanism positioned proximally of the at
3 least one resilient member.

1 22. The method of claim 21, further comprising recording a maximum
2 degree of cinching force exerted.

1 23. The method of claim 21, wherein monitoring a cinching force
2 comprises compressing a spring element when retracting the grasper such that the spring
3 feeds a restoring force back through the tubular member.

1 24. A system for controlled cinching of a tissue anchor, the system
2 comprising:
3 a grasper adapted to engage the tissue anchor or a suture depending from the
4 tissue anchor;
5 a cinching assembly defining a lumen for passage of the grasper therethrough
6 and to cinch the engaged tissue anchor or suture against a portion of the cinching assembly;
7 and
8 a force feedback mechanism configured to indicate a degree of anchor
9 cinching force.

1 25. The system of claim 24, wherein the force feedback mechanism
2 comprises a compression spring configured to apply a restoring force during anchor cinching.

1 26. The system of claim 24, wherein the force feedback mechanism
2 comprises a longitudinally translatable marking element configured to record a maximum
3 degree of exerted anchor cinching force.

1 27. The system of claim 24, wherein the cinching assembly comprises:
2 a tubular member having a lumen with a distal outlet such that the grasper is
3 able to be advanced coaxially through the lumen, wherein a distal portion of the tubular
4 member defines a compartment for laterally stabilizing a cinching mechanism relative to the
5 tubular member; and
6 at least one resilient member that at least partially obstructs the lumen and is
7 adapted to be reversibly displaced by the grasper when the grasper is passed beyond the distal
8 outlet of the lumen.

1 28. Apparatus for grasping and cinching a tissue anchor, the apparatus
2 comprising:
3 a tube having a lumen with a distal outlet;
4 a resilient member that at least partially obstructs the lumen; and
5 a grasper configured for coaxial advancement through the lumen,
6 wherein the grasper is configured to reversibly displace the resilient member
7 and extend beyond the distal outlet of the lumen to grasp and cinch the tissue anchor.

1 29. The apparatus of claim 28, wherein the apparatus is configured for
2 advancement into a patient's gastrointestinal lumen.

1 30. The apparatus of claim 28, wherein the grasper is configured to engage
2 suture coupled to the tissue anchor.

1 31. The apparatus of claim 28, wherein the resilient member is configured
2 to cinch the anchor.

1 32. The apparatus of claim 31, wherein the anchor further comprises a
2 cinching mechanism, the resilient member configured to cinch the anchor via interaction with
3 the cinching mechanism.

1 33. The apparatus of claim 32, wherein the cinching mechanism is
2 configured to lock the anchor in a deployed configuration.

1 34. The apparatus of claim 28, wherein the resilient member at least
2 partially obstructs the distal outlet of the lumen.

1 35. The apparatus of claim 28, wherein the tube further comprises a slot in
2 communication with the lumen, and wherein the resilient member is disposed within the slot
3 to at least partially obstruct the lumen.

1 36. The apparatus of claim 28, wherein the apparatus is configured for use
2 with tissue plication apparatus.

1 37. Apparatus for grasping and cinching a tissue anchor, the apparatus
2 comprising:
3 a tube having a lumen; and
4 a snare device configured for coaxial advancement through the lumen, the
5 snare device comprising a resilient loop configured to coact with an element of the snare
6 device or of the tissue anchor for grasping and cinching the tissue anchor.

1 38. The apparatus of claim 37, wherein the coating element comprises a
2 resilient latch of the snare device that forms an actuatable mouth with the resilient loop for
3 grasping and cinching the tissue anchor.

1 39. The apparatus of claim 37, wherein the coating element comprises a
2 protrusion of the tissue anchor that may be engaged by the snare device through collapse of
3 the snare device within the lumen of the tube.

1 40. The apparatus of claim 37, wherein the apparatus is configured for
2 advancement into a patient's gastrointestinal lumen.

1 41. The apparatus of claim 37, wherein the snare device is configured to
2 grasp suture coupled to the tissue anchor.

1 42. The apparatus of claim 37, wherein the tube is configured to cinch the
2 anchor.

1 43. The apparatus of claim 42, wherein the tissue anchor further comprises
2 a cinching mechanism, the tube configured to cinch the tissue anchor via interaction with the
3 cinching mechanism.

1 44. The apparatus of claim 43, wherein the cinching mechanism is
2 configured to lock the anchor in a deployed configuration.

1 45. The apparatus of claim 37, wherein the apparatus is configured for use
2 with tissue plication apparatus.

1 46. A method for grasping and cinching a tissue anchor, the method
2 comprising:
3 engaging tissue with the tissue anchor;
4 advancing a grasper through a lumen of a tube having a resilient member that
5 obstructs the lumen;
6 reversibly displacing the resilient member with the grasper to remove
7 the obstruction;
8 extending the grasper beyond an outlet of the lumen; and
9 grasping a suture coupled to the tissue anchor with the grasper; and
10 retracting the suture relative to the tissue anchor to cinch the anchor.

1 47. The method of claim 46, wherein engaging tissue with a tissue anchor
2 further comprises engaging a tissue fold, and wherein cinching the anchor further comprises
3 securing the tissue fold.

1 48. The method of claim 46, wherein retracting the suture relative to the
2 tissue anchor to cinch the anchor further comprises locking the anchor in a deployed
3 configuration.

1 49. The method of claim 46, wherein retracting the suture further
2 comprises retracting the grasper and grasped suture within the lumen of the tube such that the
3 resilient member again obstructs the lumen.

1 50. The method of claim 49, wherein cinching the anchor further
2 comprises engaging a cinching mechanism of the anchor with the obstructing resilient
3 member.

1 51. The method of claim 46, wherein advancing a grasper through a lumen
2 of a tube having a resilient member that obstructs the lumen further comprises advancing the

3 grasper through the lumen of a tube having a resiliently expandable collet that obstructs the
4 lumen, and

5 wherein reversibly displacing the resilient member with the grasper to remove
6 the obstruction further comprises reversibly expanding the collet with the grasper.

1 52. A method for grasping and cinching a tissue anchor, the method
2 comprising:

3 engaging tissue with the tissue anchor;

4 advancing a snare device through a lumen of a tube, the snare device having a
5 resilient loop that is configured to coact with an element of the snare device or of the tissue
6 anchor;

7 capturing a suture coupled to the tissue anchor between the loop and the
8 coacting element by retracting the snare device relative to the tube; and

9 retracting the suture relative to the tissue anchor to cinch the anchor.

1 53. The method of claim 52, wherein engaging tissue with a tissue anchor
2 further comprises engaging a tissue fold, and wherein cinching the anchor further comprises
3 securing the tissue fold.

1 54. The method of claim 52, wherein capturing the suture between the loop
2 and the coacting element further comprises capturing the suture between the loop and a
3 coacting resilient latch of the snare device by retracting the snare device relative to the tube to
4 approximate the loop and the latch.

1 55. The method of claim 52, wherein capturing the suture between the loop
2 and the coacting element further comprises capturing the suture between the loop and a
3 protrusion of the tissue anchor by retracting the snare device relative to the tube to collapse
4 the snare device within the lumen of the tube and engage the protrusion.

1 56. The method of claim 52, wherein retracting the suture relative to the
2 tissue anchor further comprises:

3 retracting the snare device and captured suture within the lumen of the tube;

4 and

5 engaging a cinching mechanism of the anchor with the tube.

1 57. The method of claim 52, wherein retracting the suture relative to the
2 tissue anchor to cinch the anchor further comprises locking the anchor in a deployed
3 configuration.

1 58. The apparatus of claim 28 wherein the resilient member comprises a
2 resiliently expandable collet, and wherein the grasper configured to reversibly displace the
3 resilient member comprises a grasper configured to reversibly expand the collet.

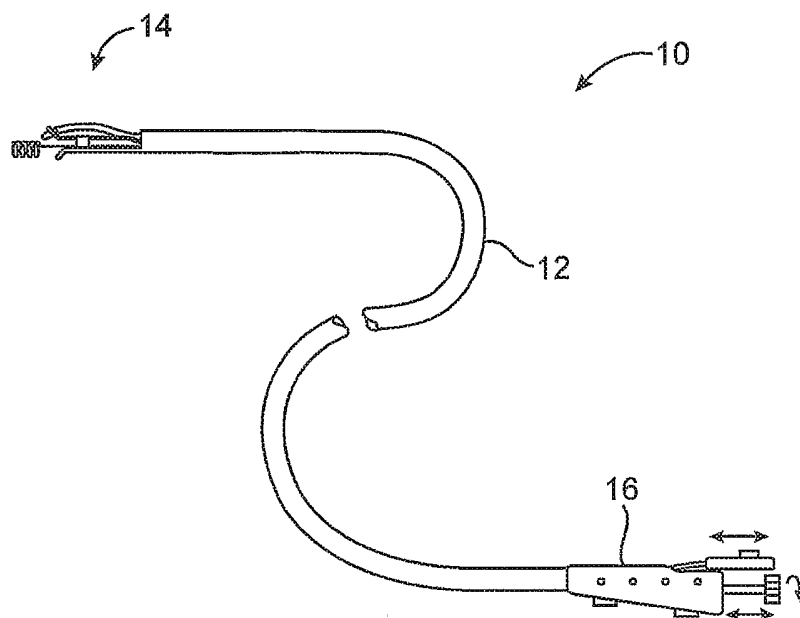

FIG. 1A

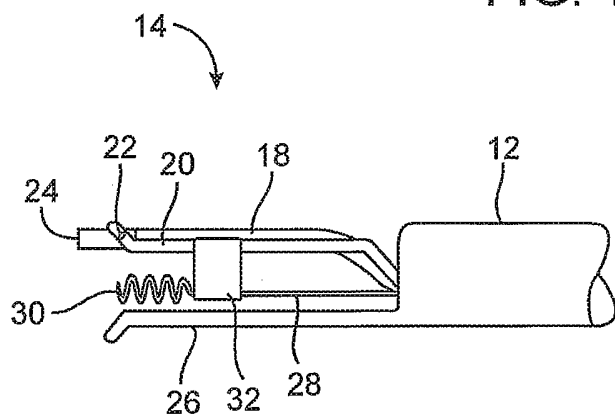

FIG. 1B

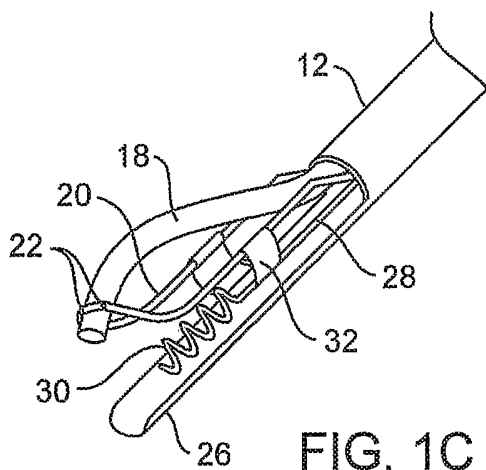
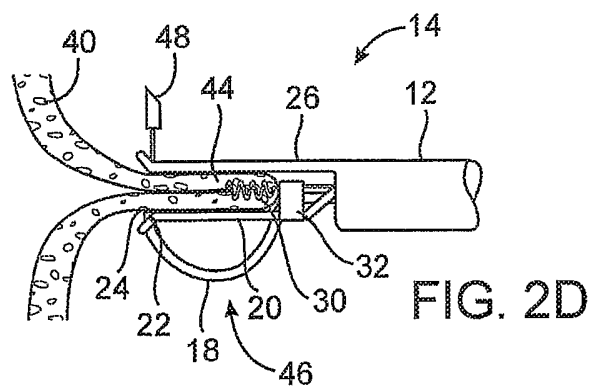
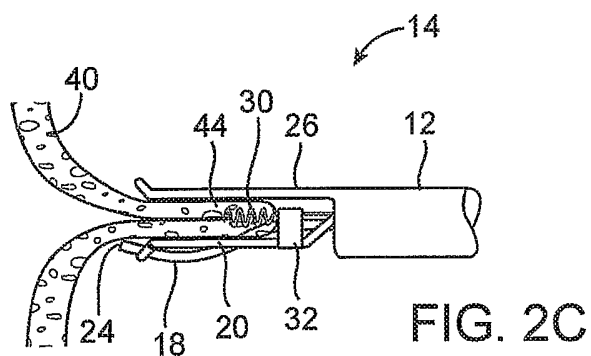
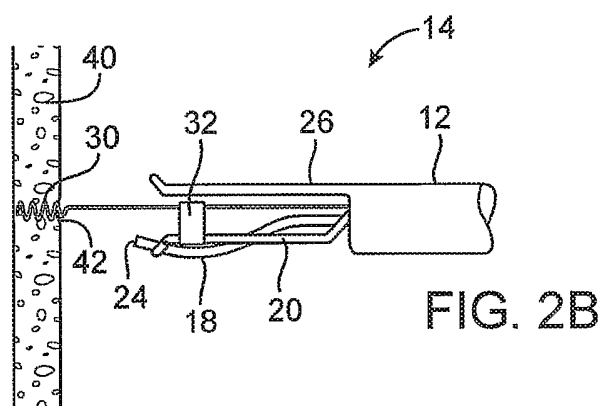
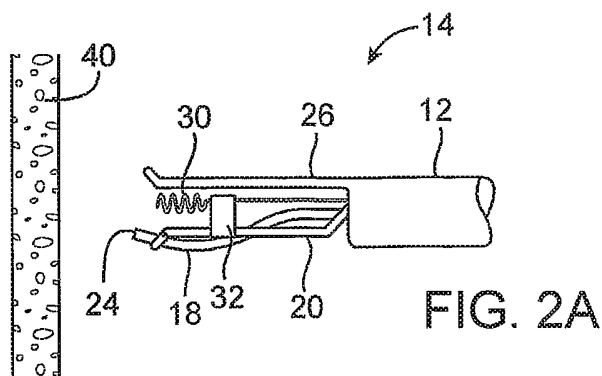

FIG. 1C



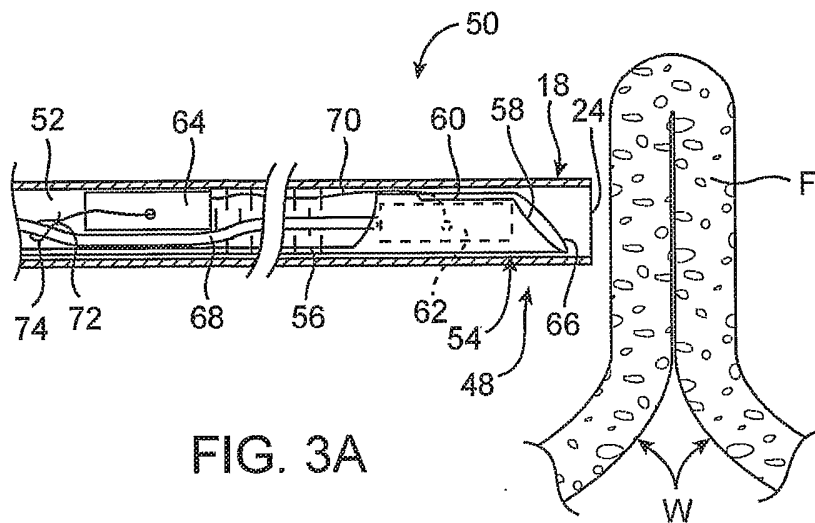

FIG. 3A

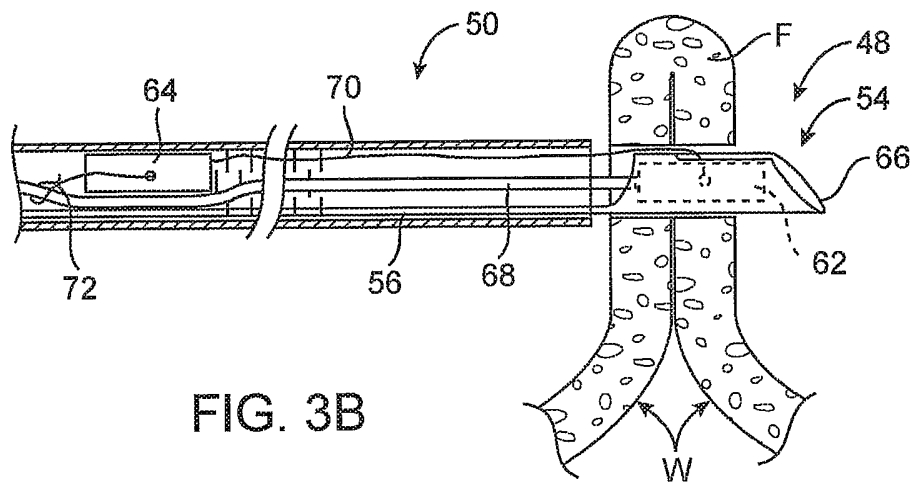

FIG. 3B

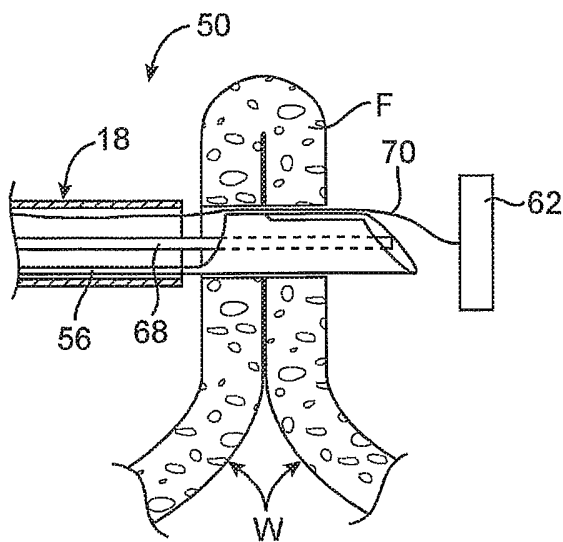

FIG. 3C

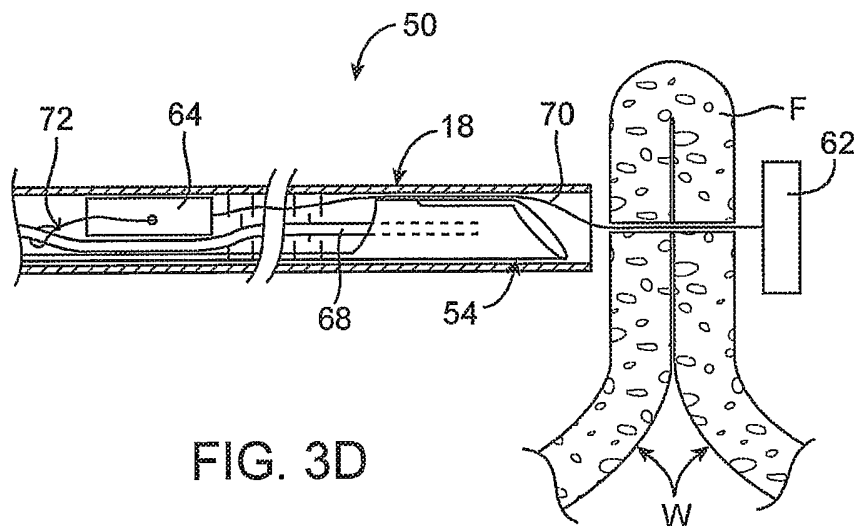
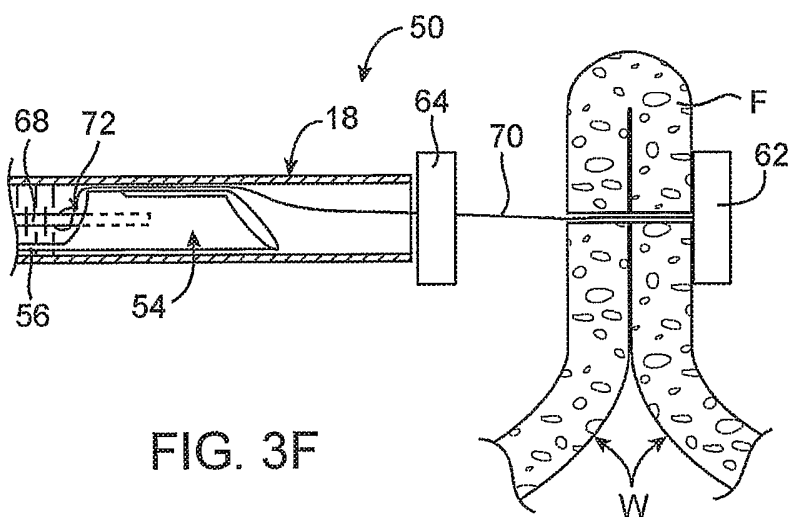
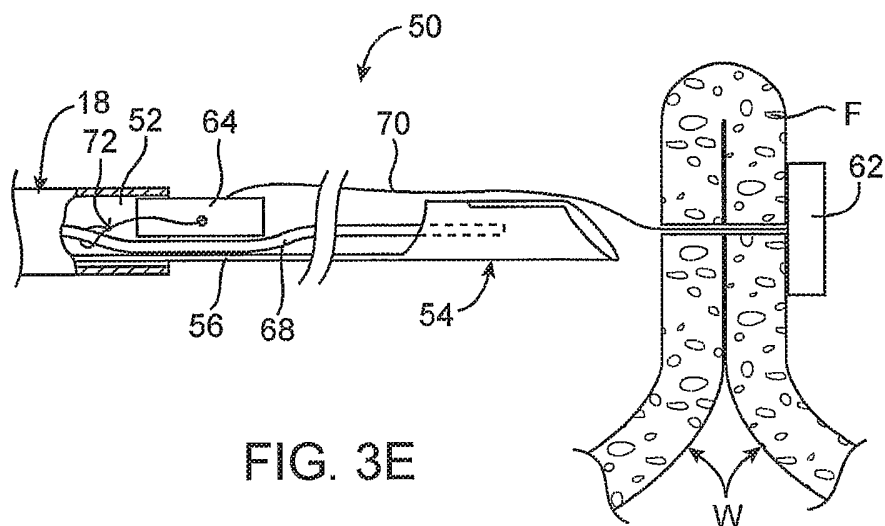

FIG. 3D



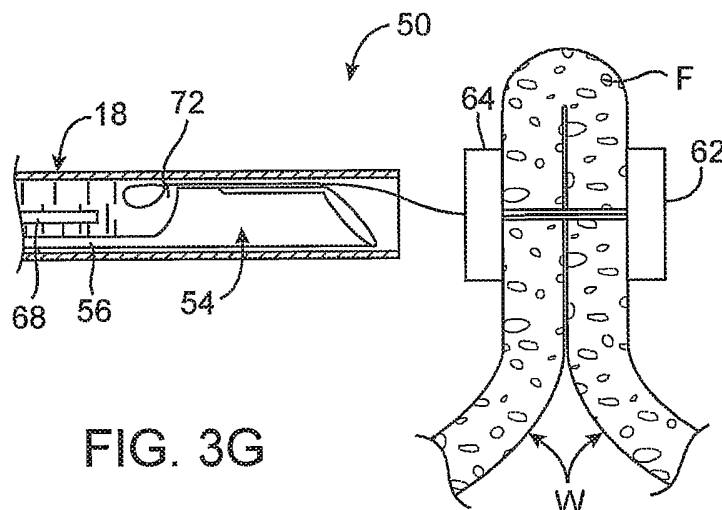

FIG. 3G

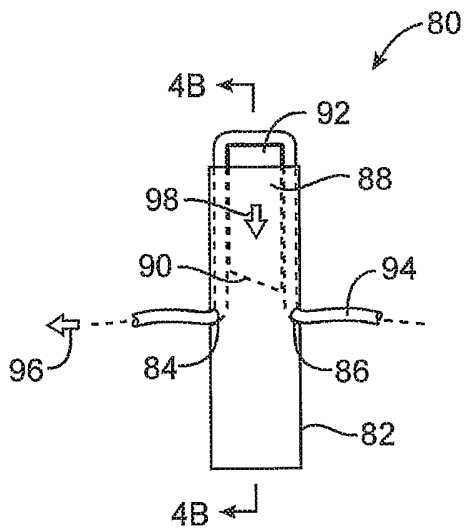

FIG. 4A

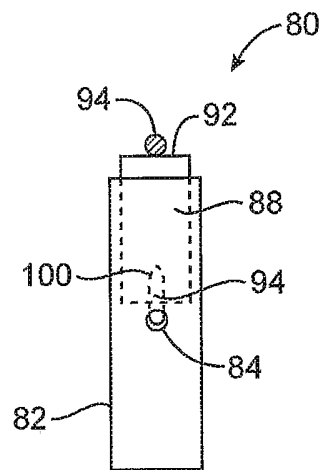

FIG. 4B

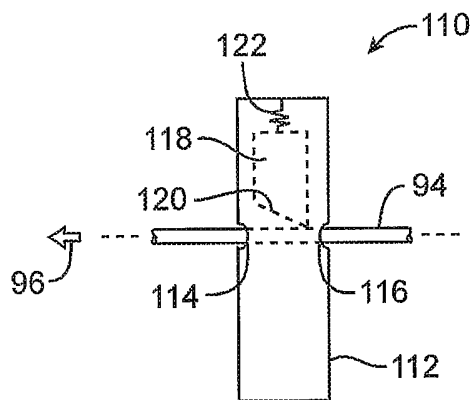

FIG. 5

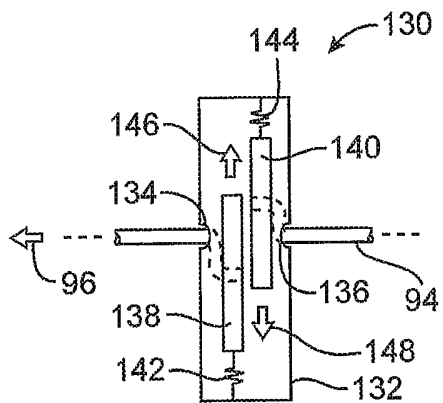

FIG. 6

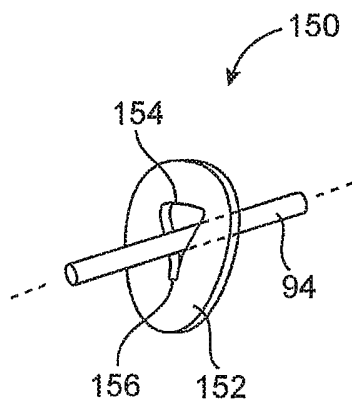

FIG. 7

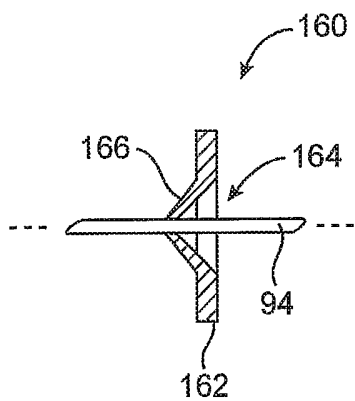

FIG. 8A

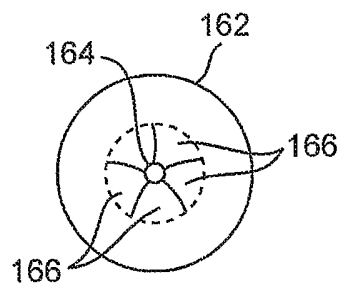

FIG. 8B

9/66

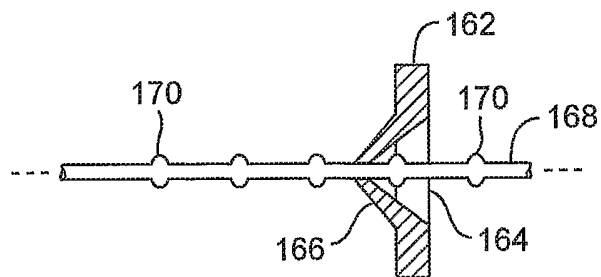

FIG. 8C

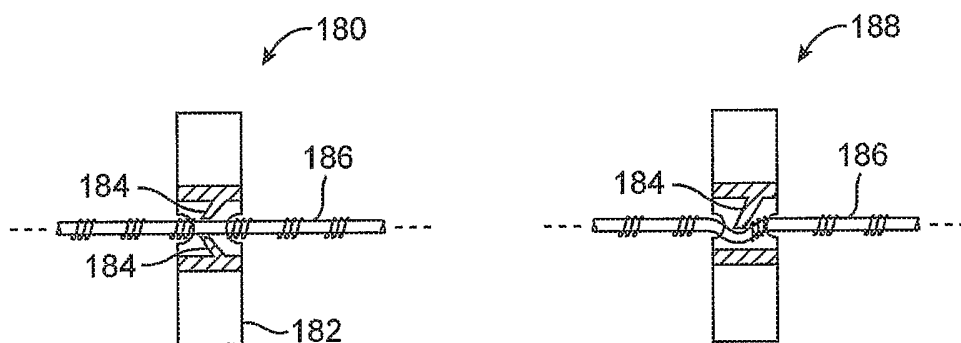

FIG. 9A

FIG. 9B

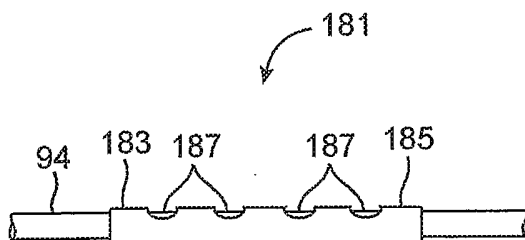

FIG. 9C

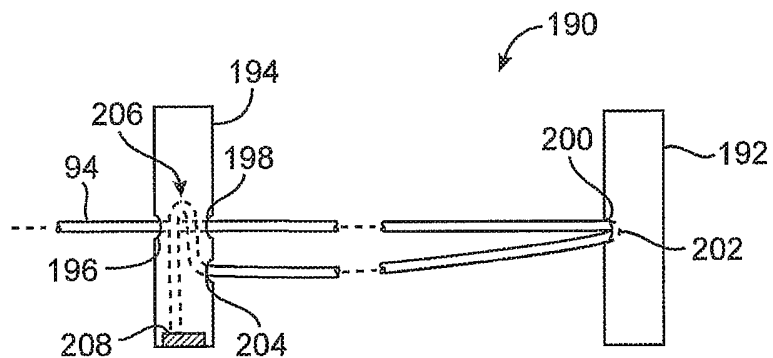

FIG. 10

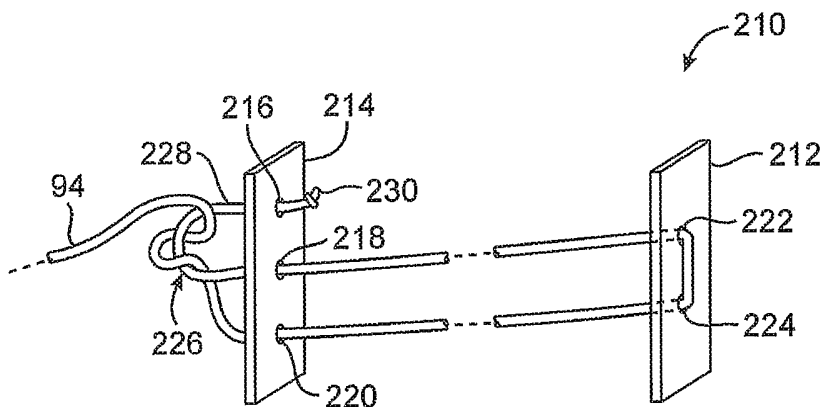

FIG. 11A

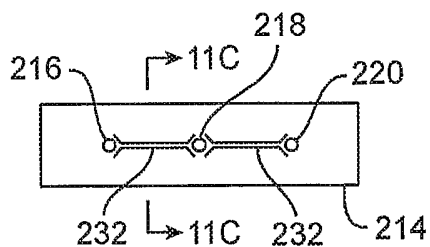

FIG. 11B

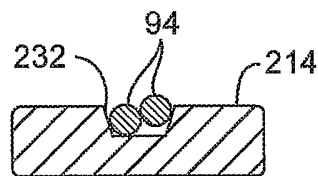

FIG. 11C

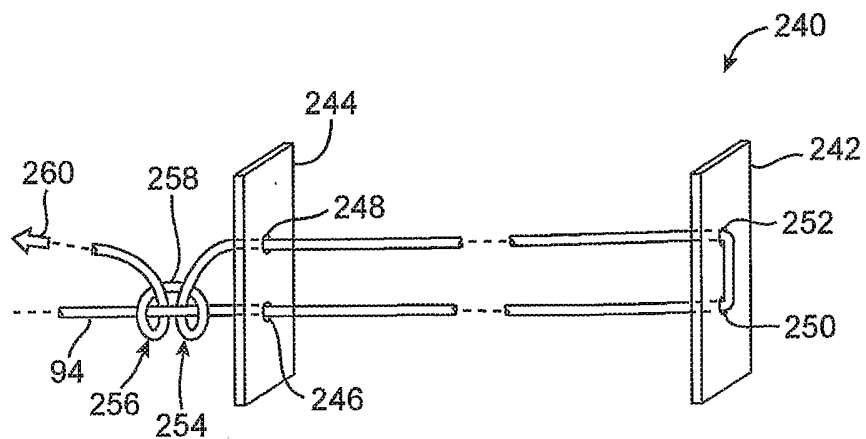

FIG. 12A

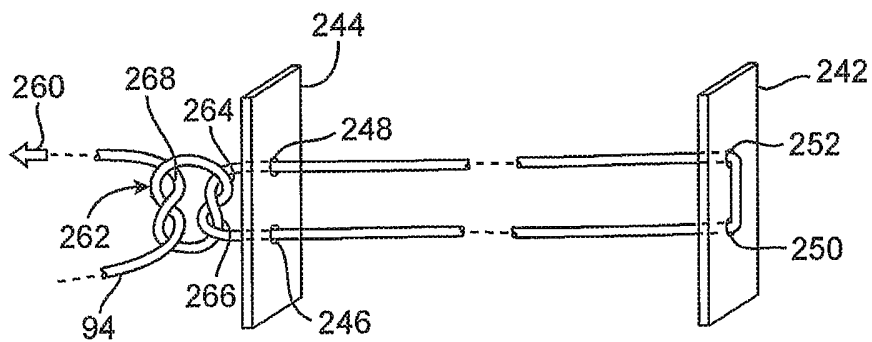

FIG. 12B

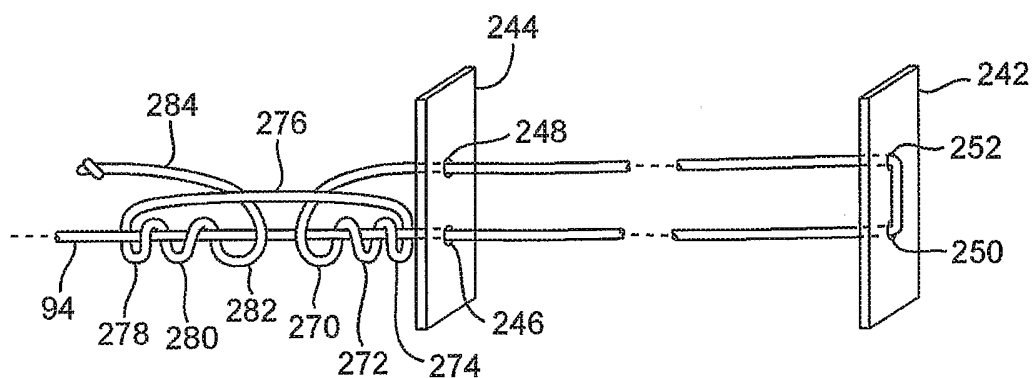

FIG. 12C

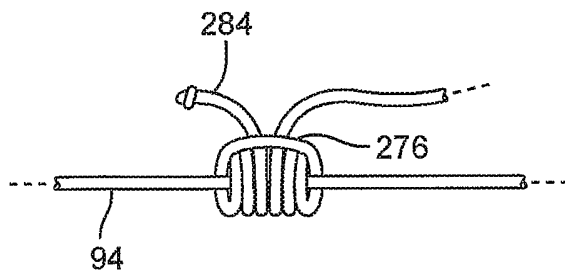

FIG. 12D

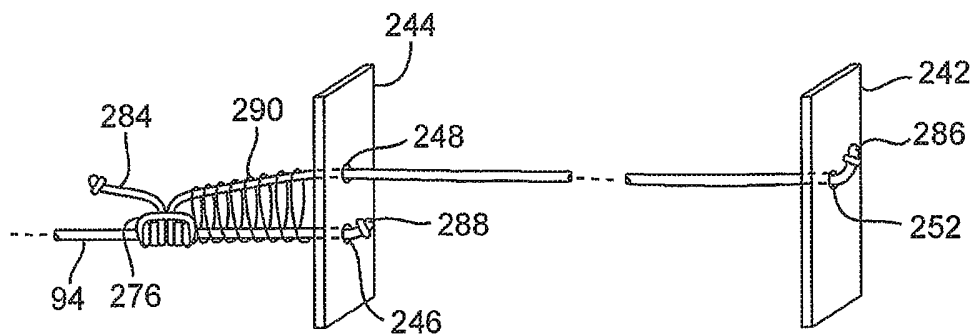

FIG. 12E

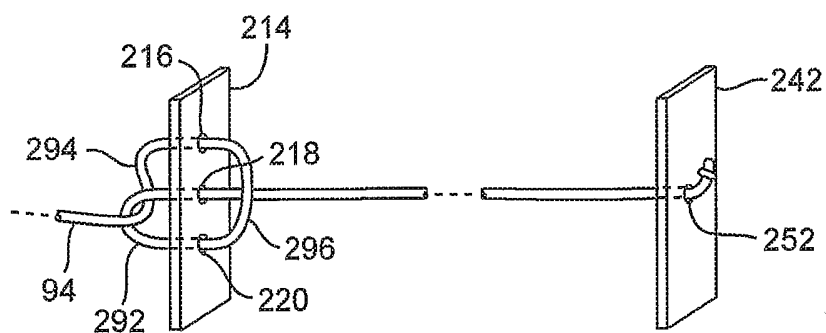

FIG. 12F

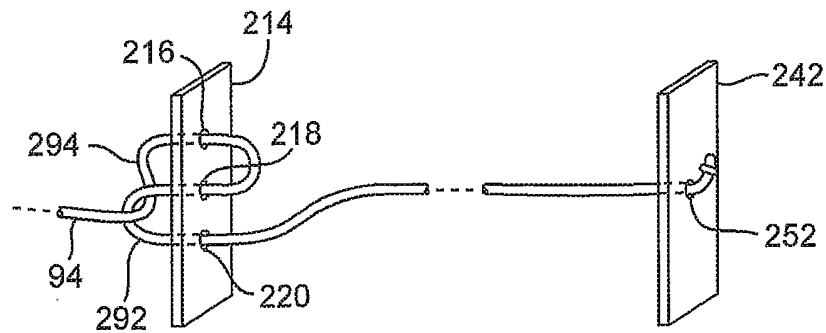

FIG. 12G

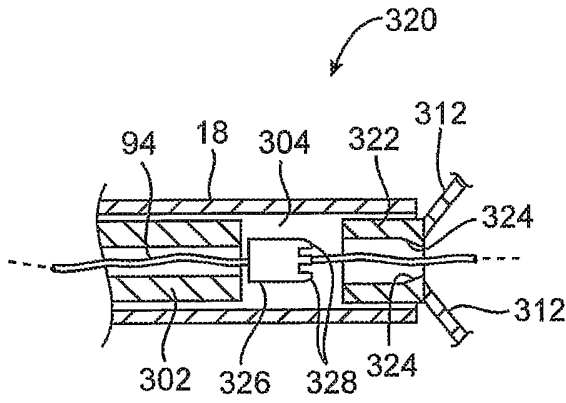

FIG. 14A

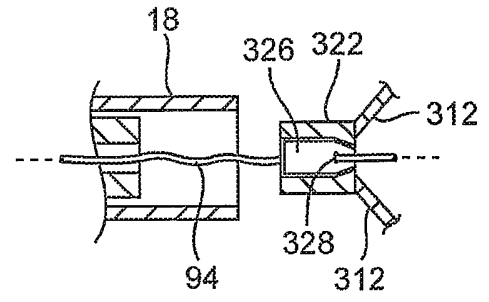

FIG. 14B

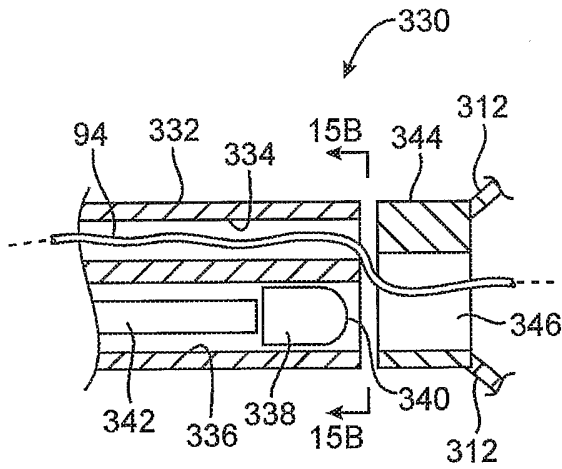

FIG. 15A

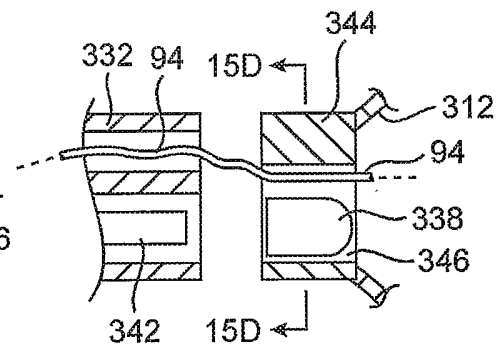

FIG. 15C

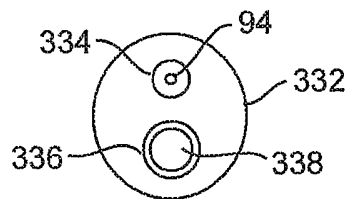

FIG. 15B

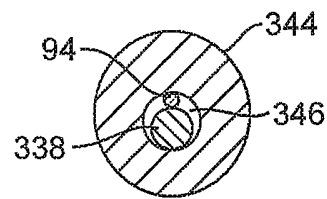

FIG. 15D

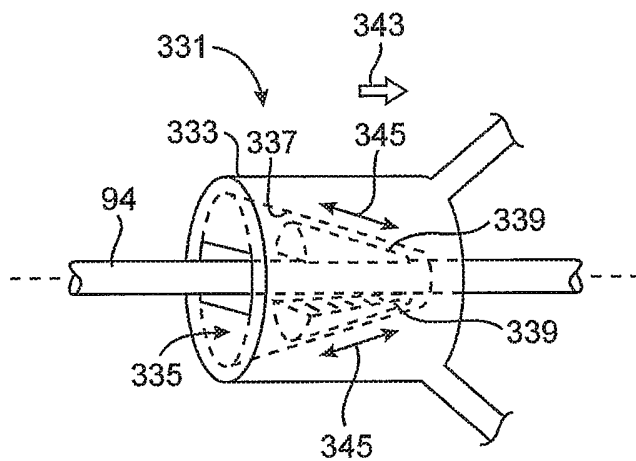

FIG. 15E

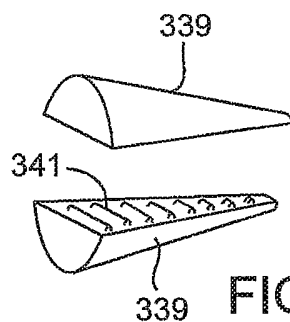

FIG. 15F

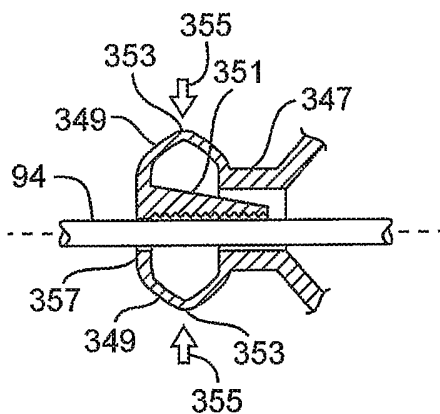

FIG. 15G

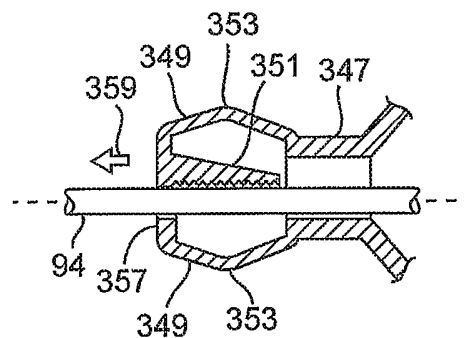
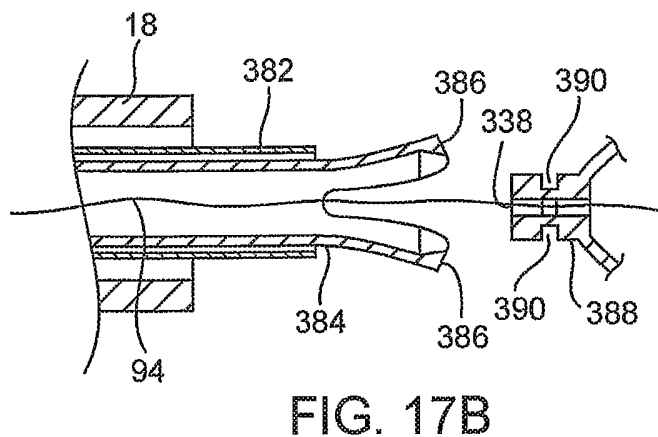
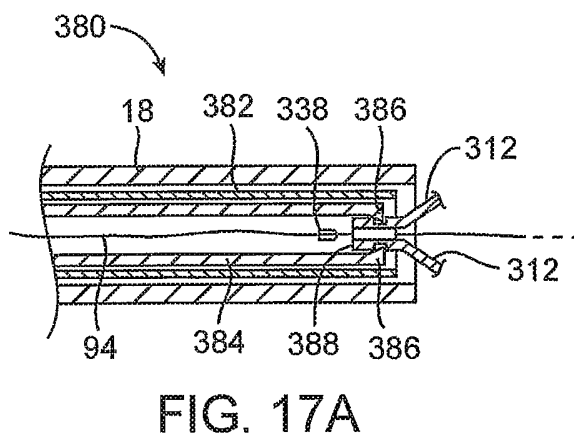
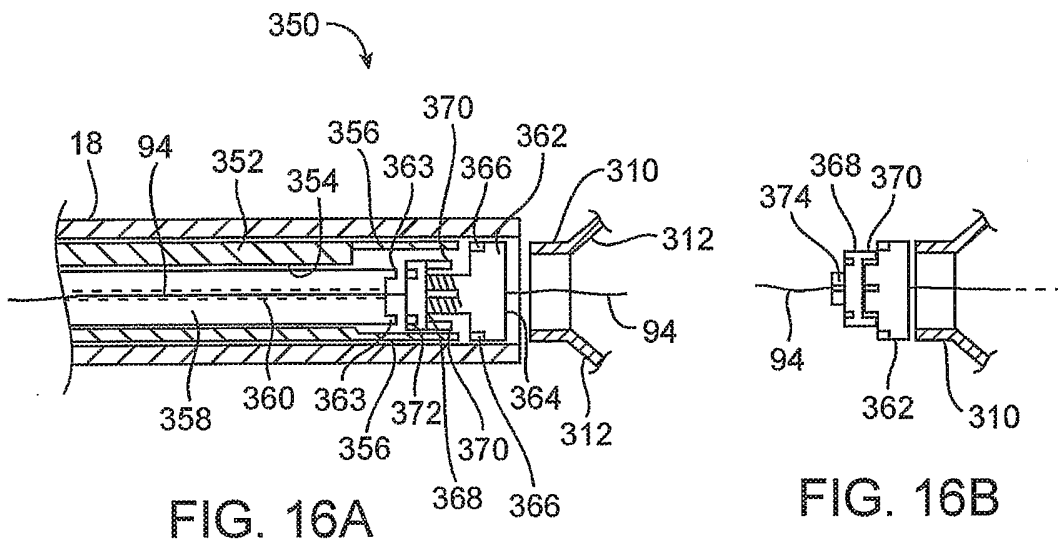

FIG. 15H

17/66



400

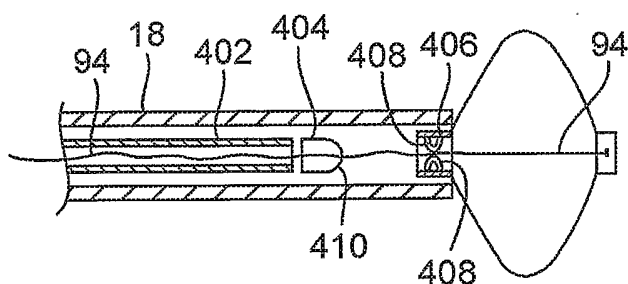

FIG. 18A

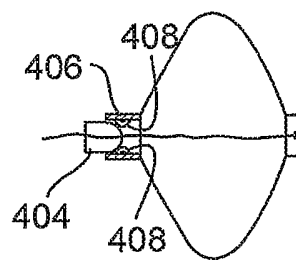

FIG. 18B



FIG. 18C

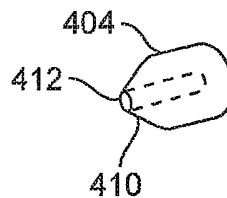

FIG. 18D

420

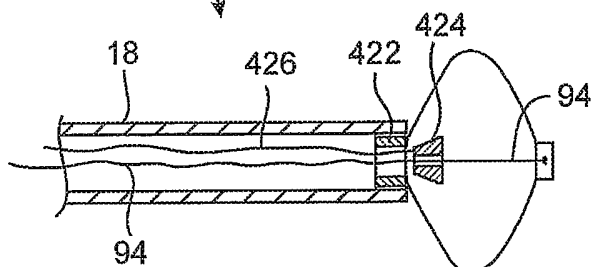

FIG. 19A

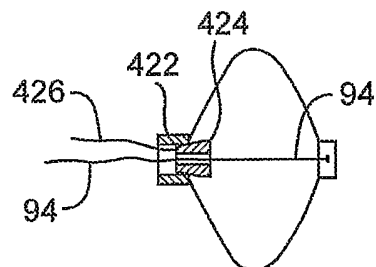

FIG. 19B

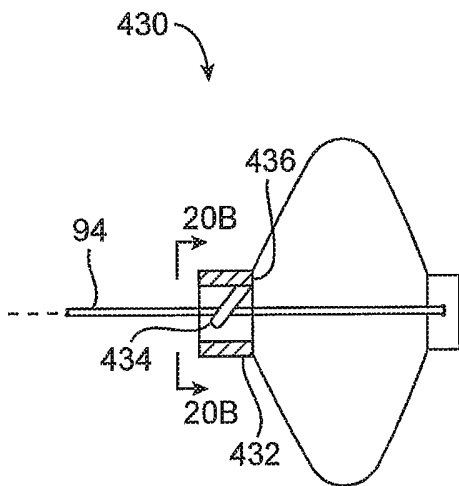

FIG. 20A

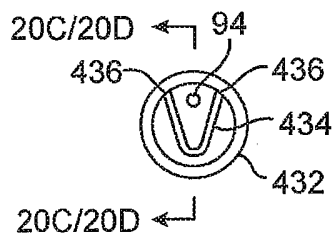

FIG. 20B

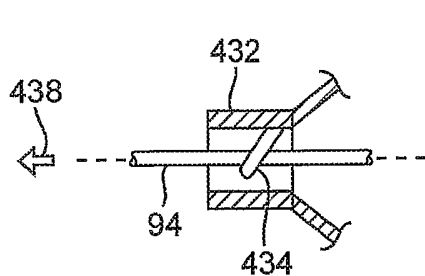

FIG. 20C

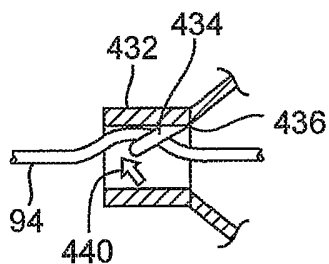

FIG. 20D

20/66

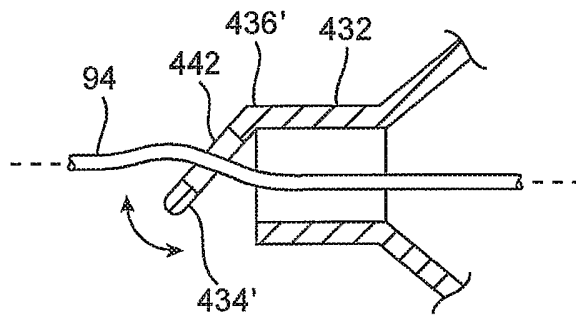

FIG. 20E

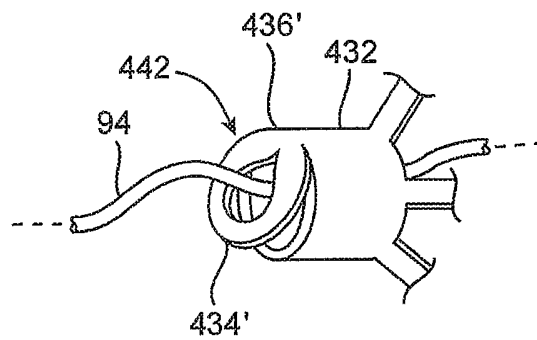

FIG. 20F

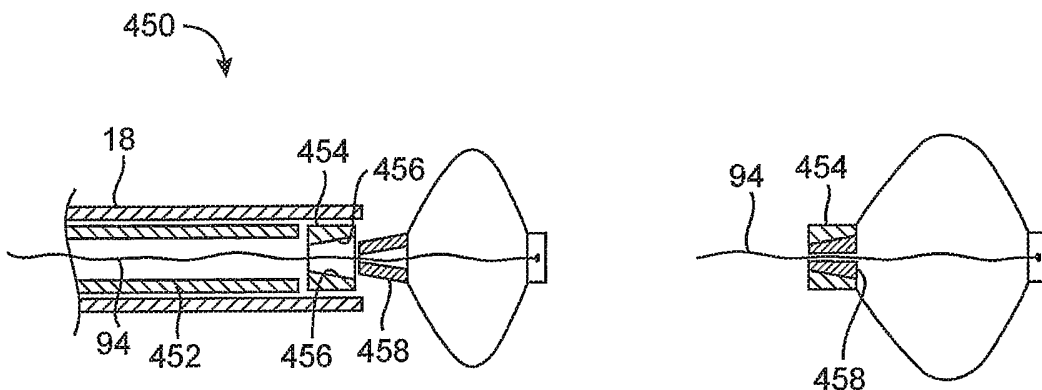

FIG. 21A

FIG. 21B

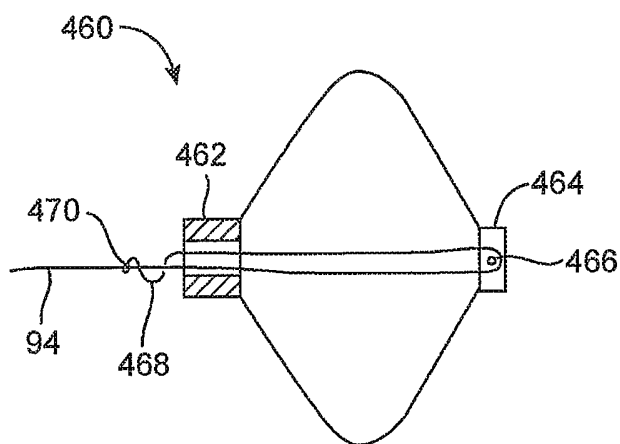

FIG. 22A

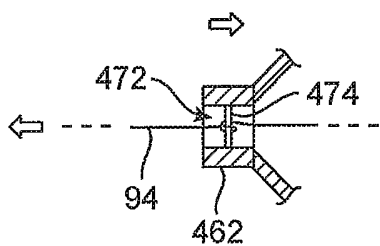

FIG. 22B

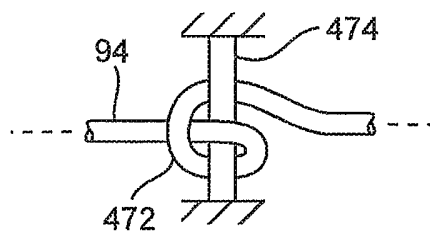

FIG. 22C

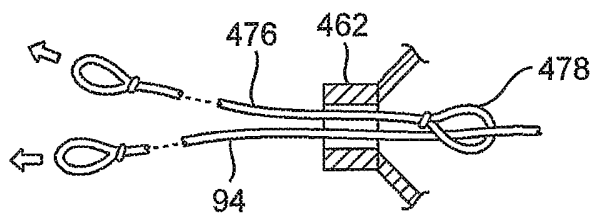

FIG. 22D

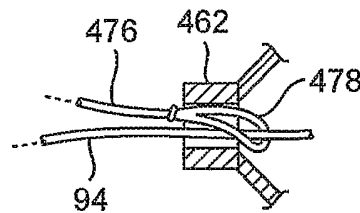

FIG. 22E

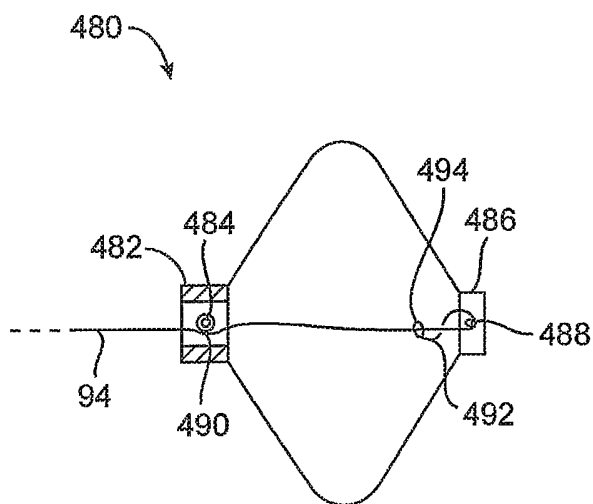

FIG. 23

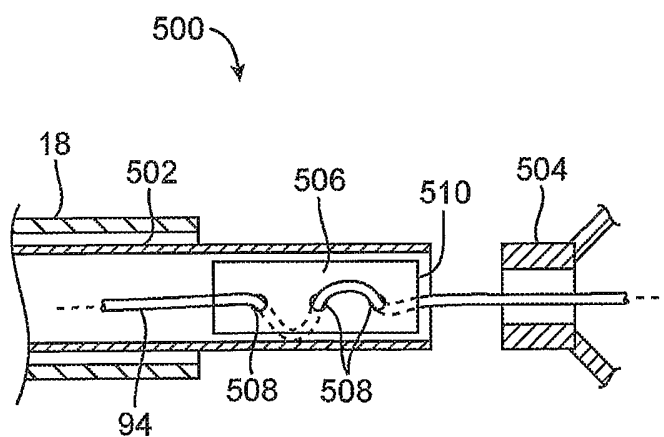

FIG. 24A

24/66

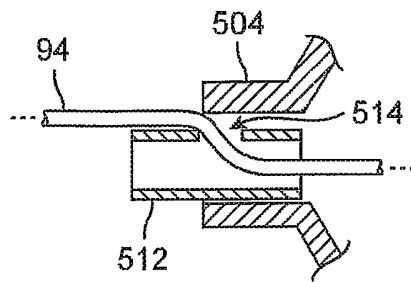

FIG. 24B

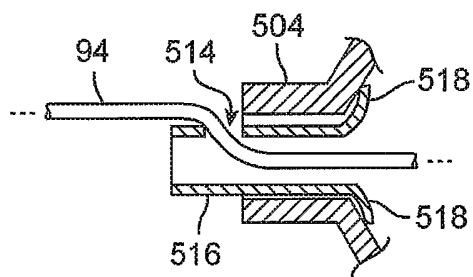

FIG. 24C

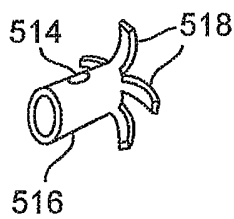

FIG. 24D

25/66

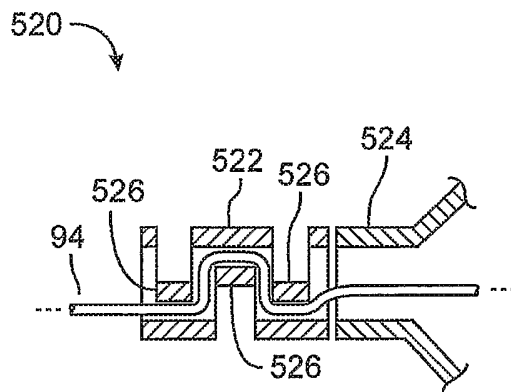

FIG. 25A

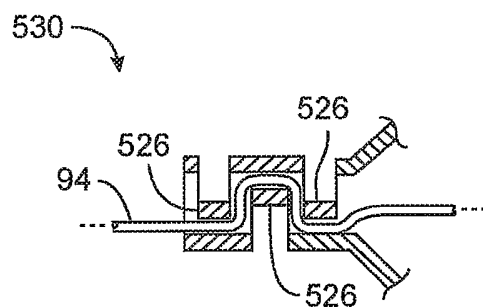

FIG. 25B

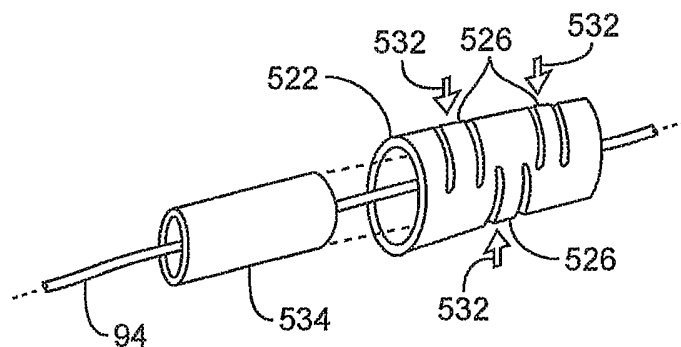

FIG. 25C

26/66

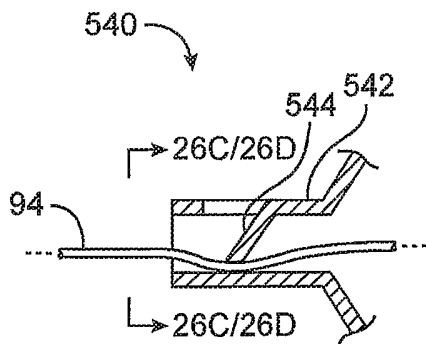

FIG. 26A

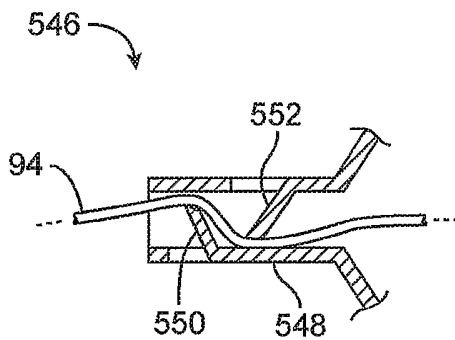

FIG. 26B

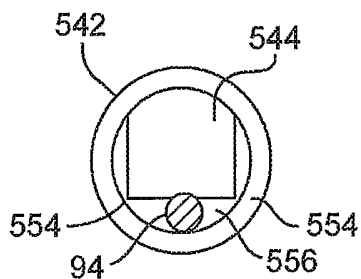

FIG. 26C

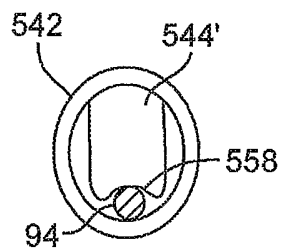

FIG. 26D

27/66

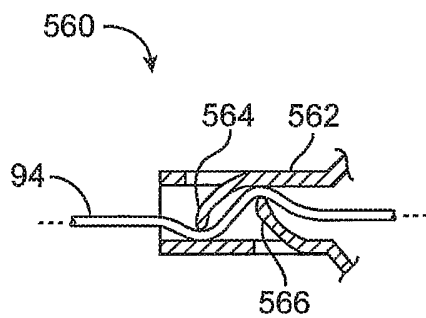

FIG. 26E

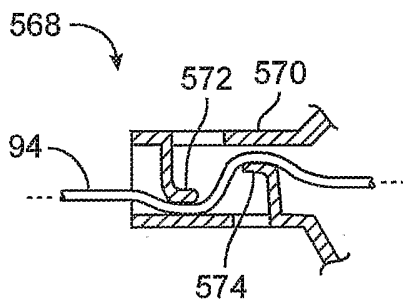

FIG. 26F

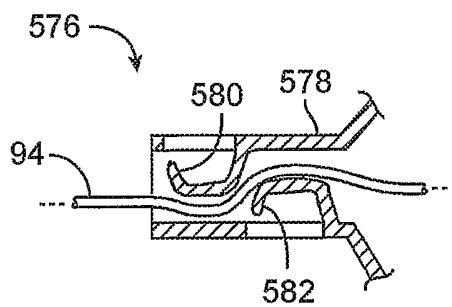

FIG. 26G

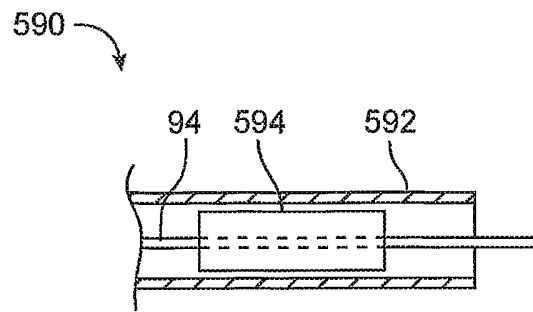

FIG. 27A

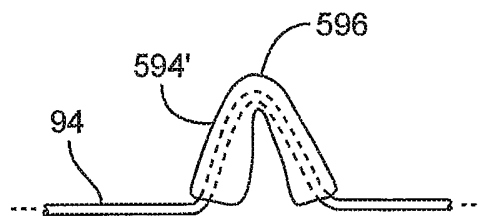

FIG. 27B

600

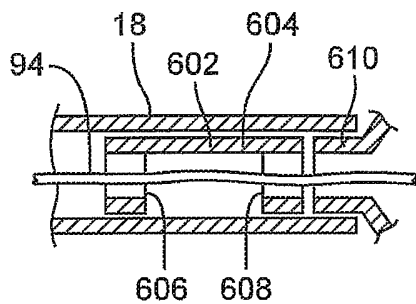

FIG. 28A

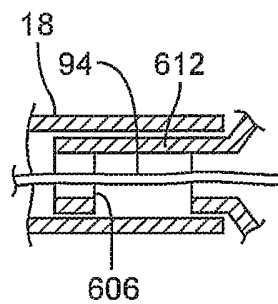

FIG. 28B

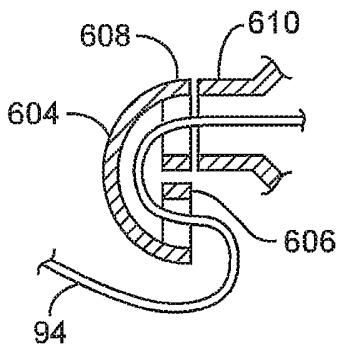

FIG. 28C

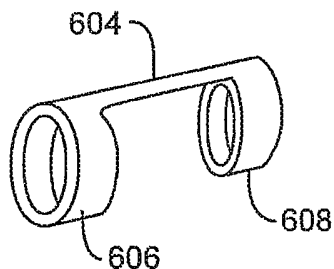

FIG. 28D

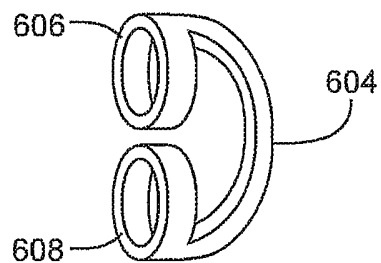

FIG. 28E

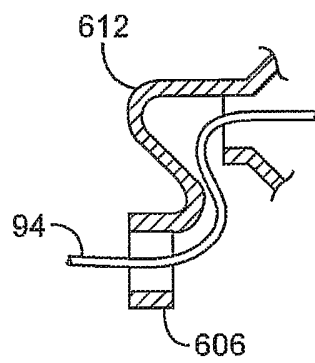

FIG. 28F

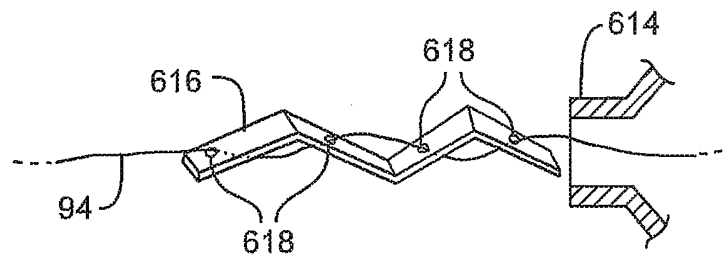

FIG. 28G

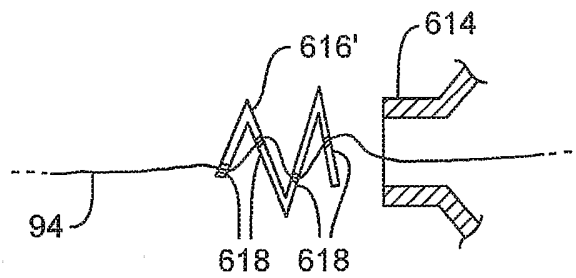

FIG. 28H

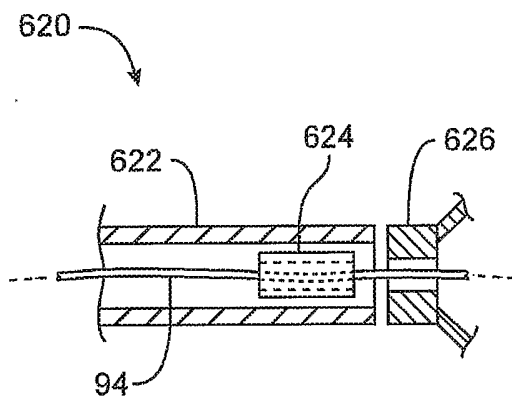

FIG. 29A

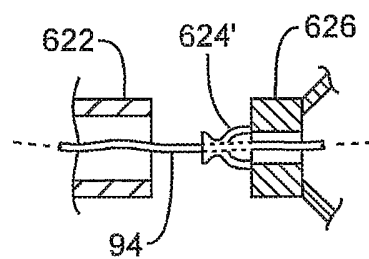

FIG. 29B

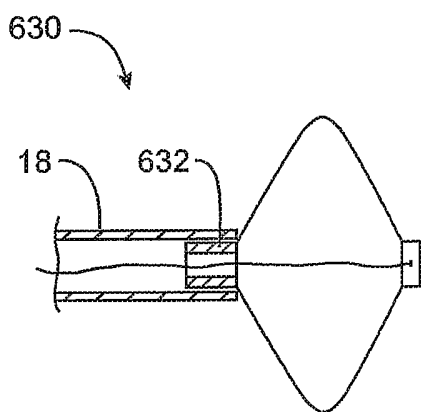

FIG. 30A

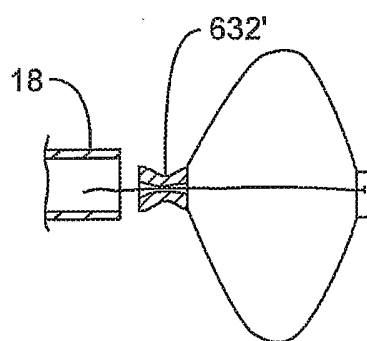

FIG. 30B

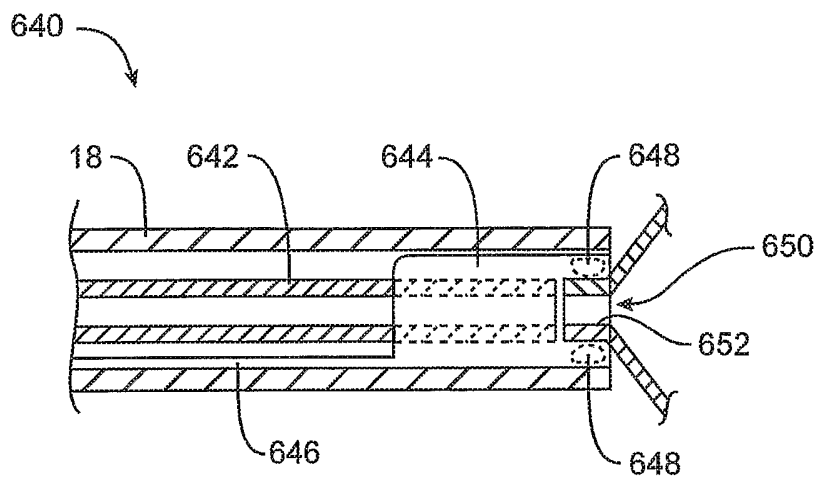

FIG. 31A

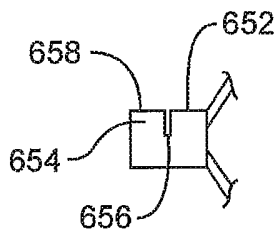

FIG. 31B

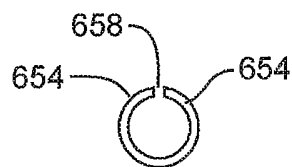

FIG. 31C

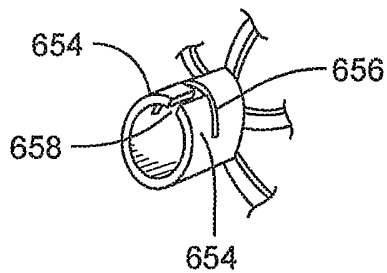

FIG. 31D

34/66

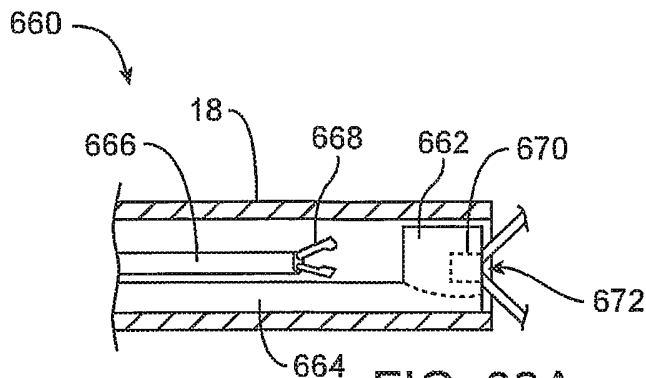

FIG. 32A

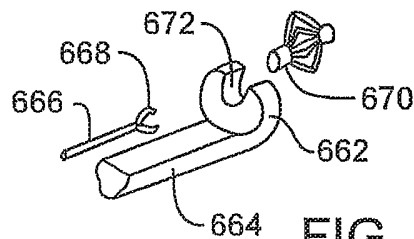

FIG. 32B

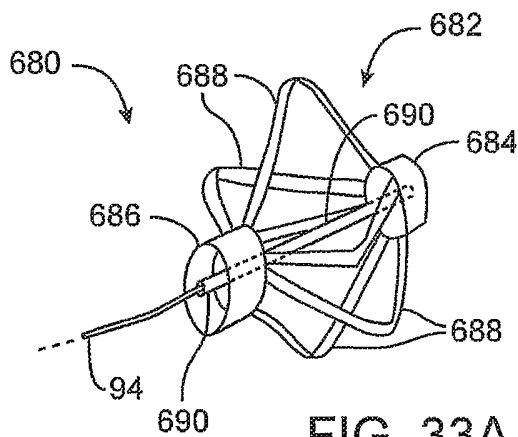

FIG. 33A

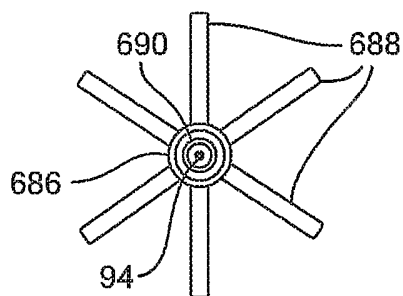

FIG. 33B

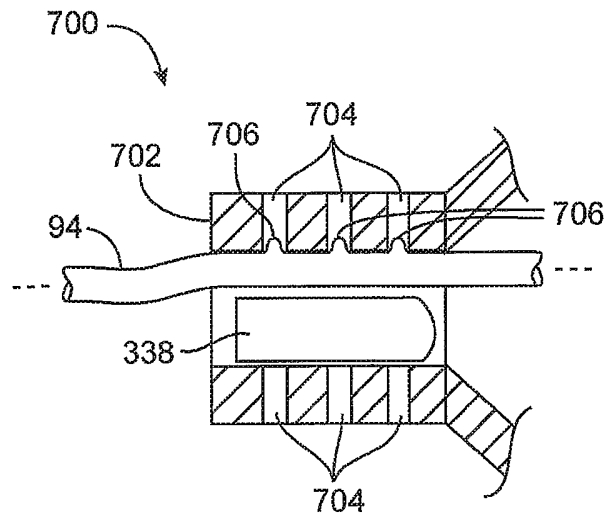

FIG. 34A

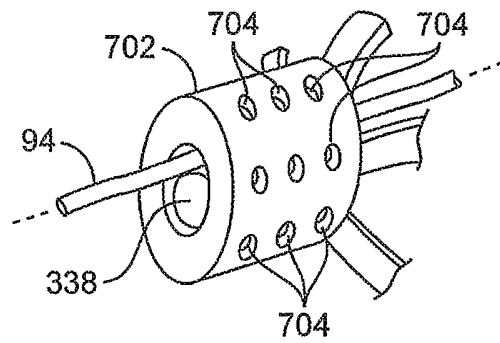

FIG. 34B

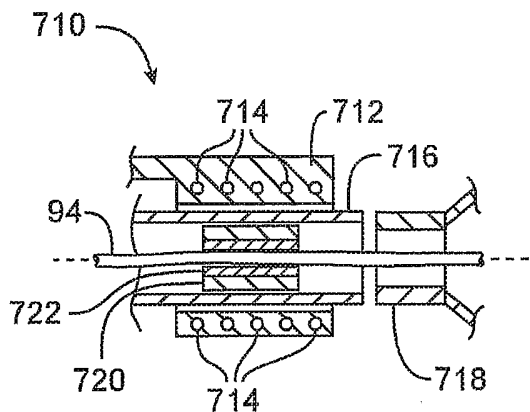

FIG. 35A

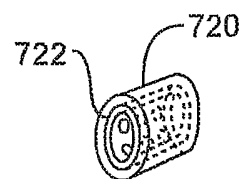

FIG. 35B

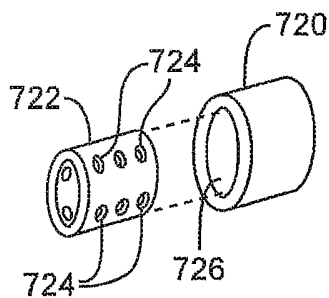

FIG. 35C

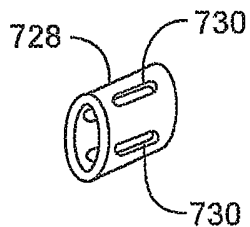

FIG. 35D

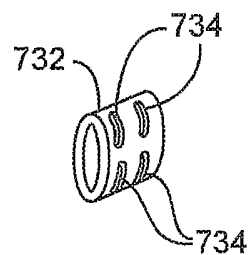

FIG. 35E

37/66

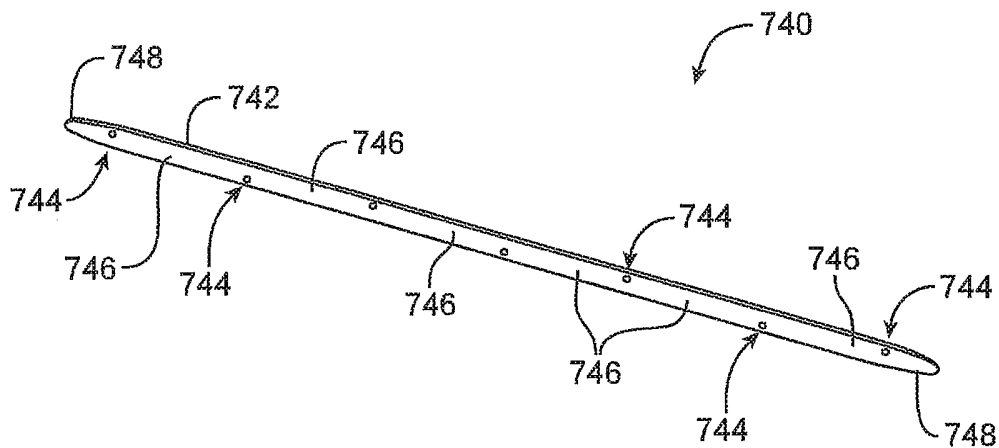

FIG. 36A

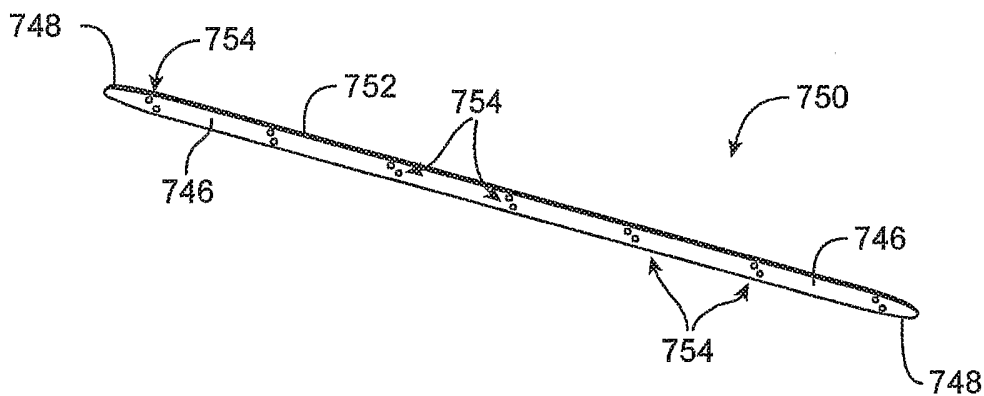

FIG. 36B

38/66

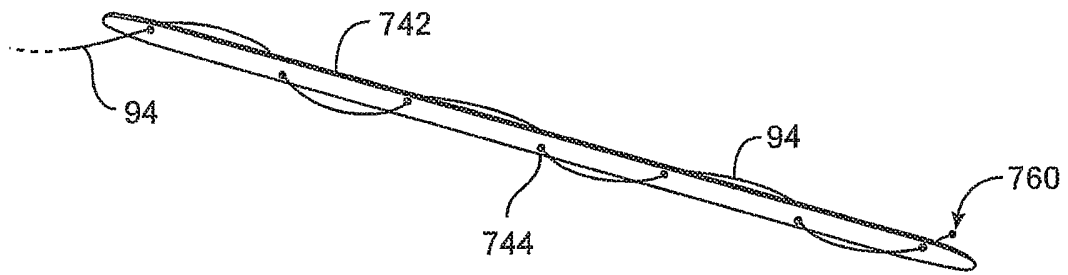

FIG. 37A

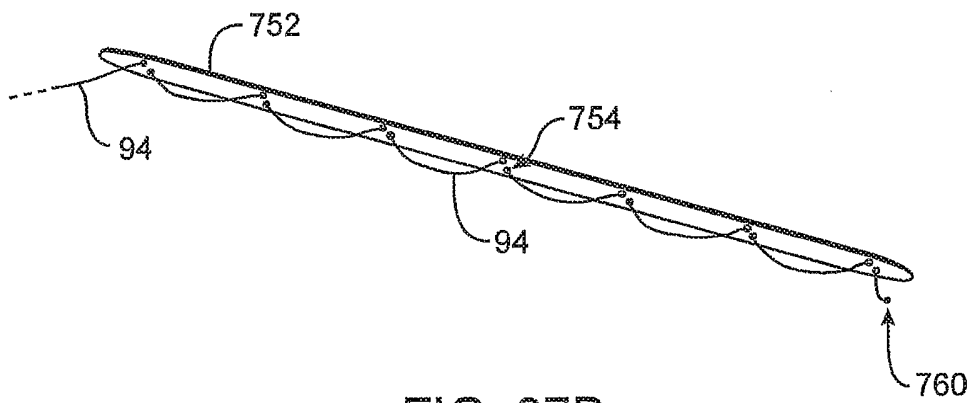

FIG. 37B

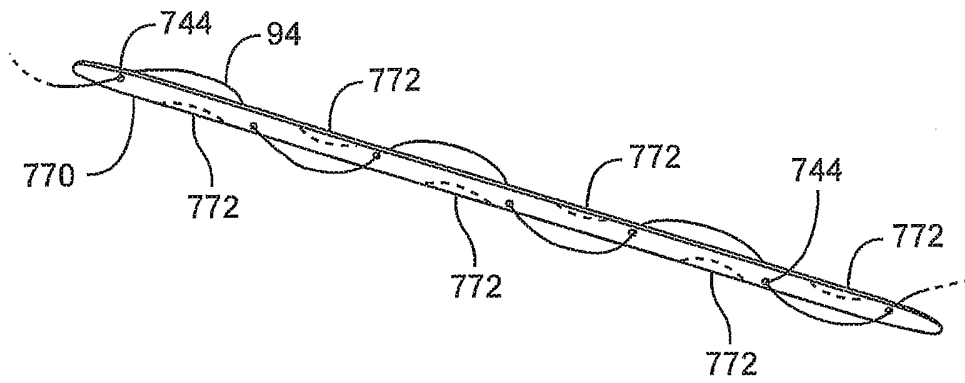

FIG. 38

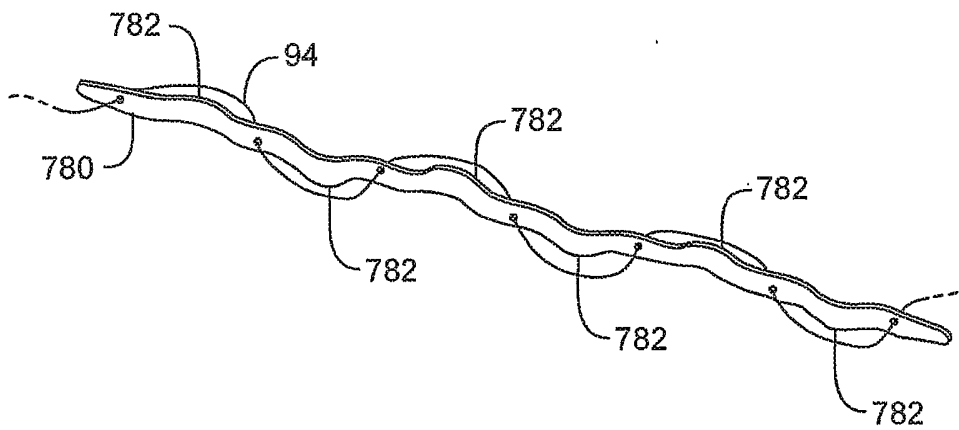

FIG. 39

40/66

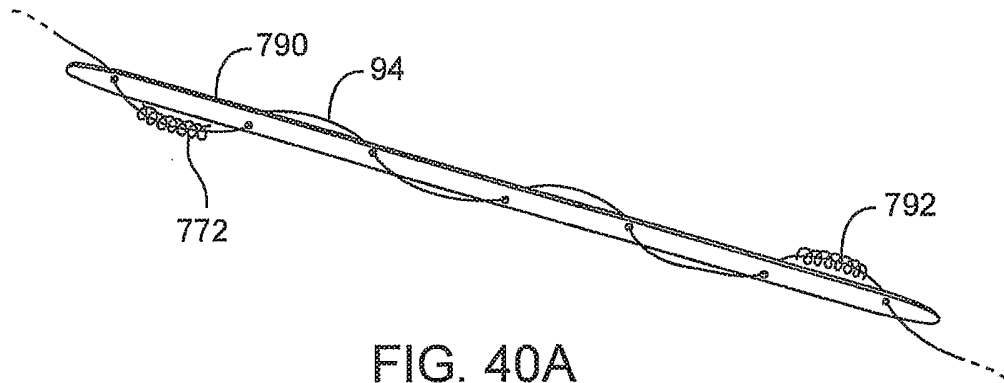

FIG. 40A

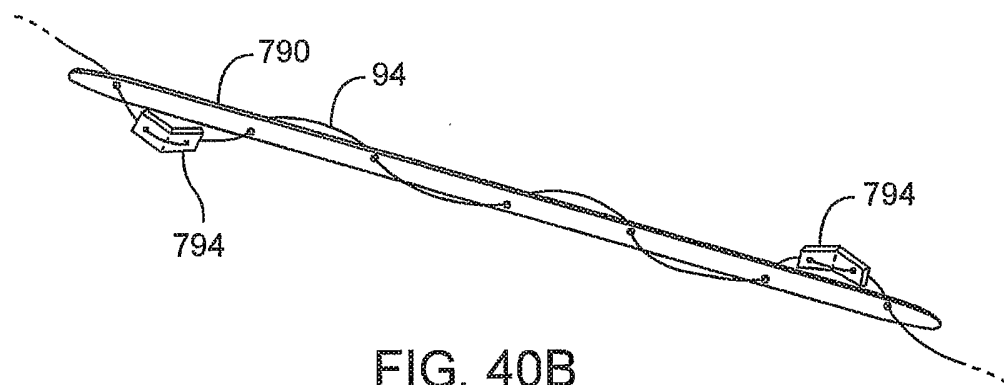

FIG. 40B

41/66

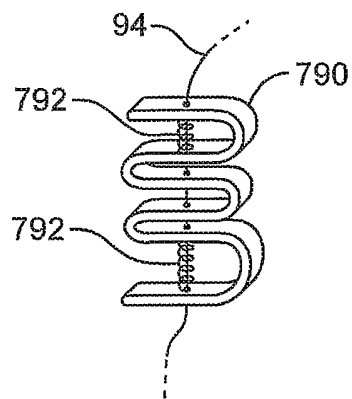

FIG. 40C

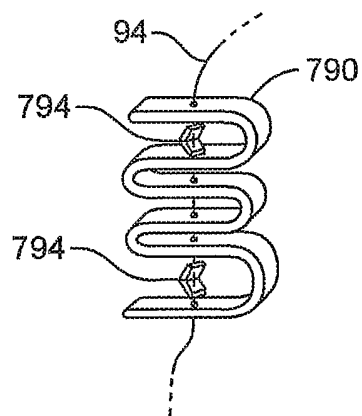
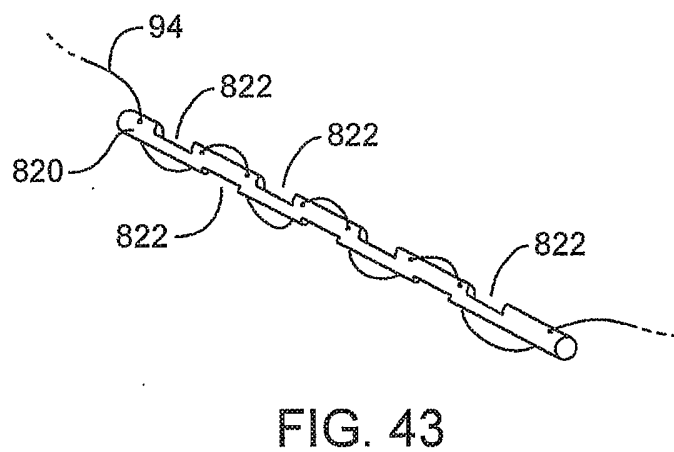
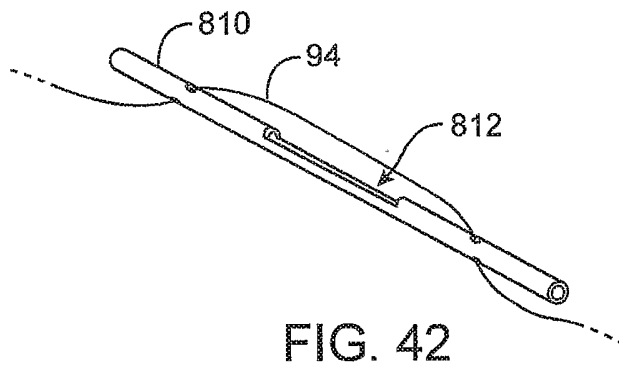
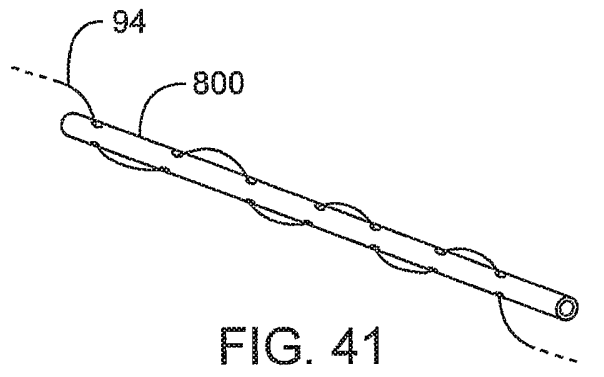

FIG. 40D



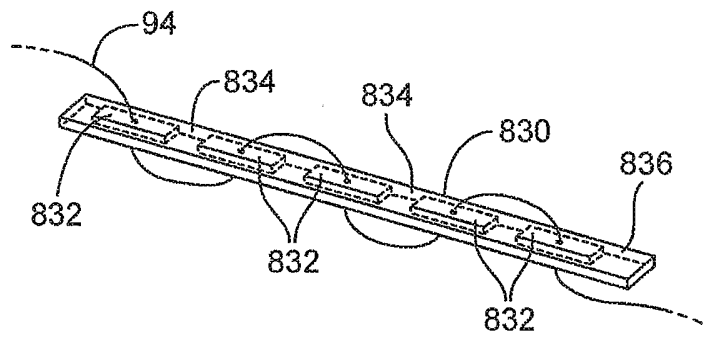

FIG. 44

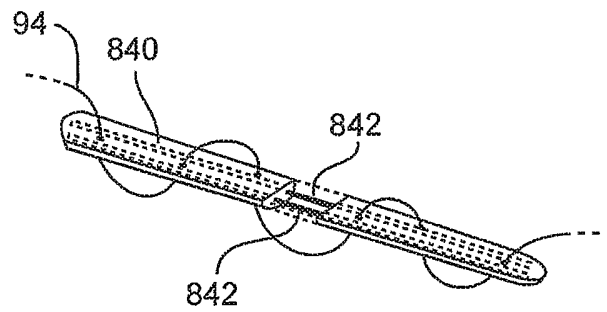

FIG. 45

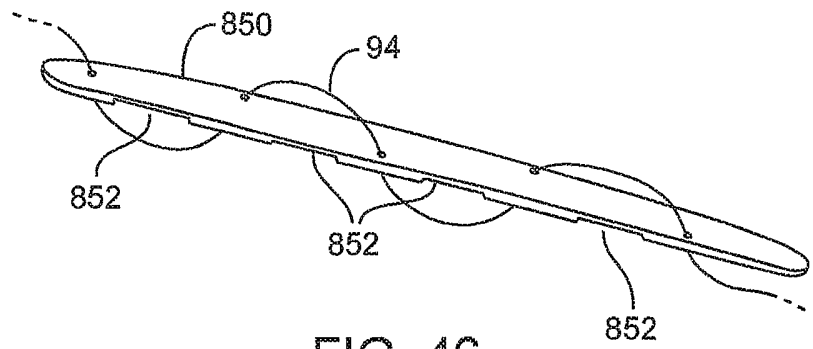

FIG. 46

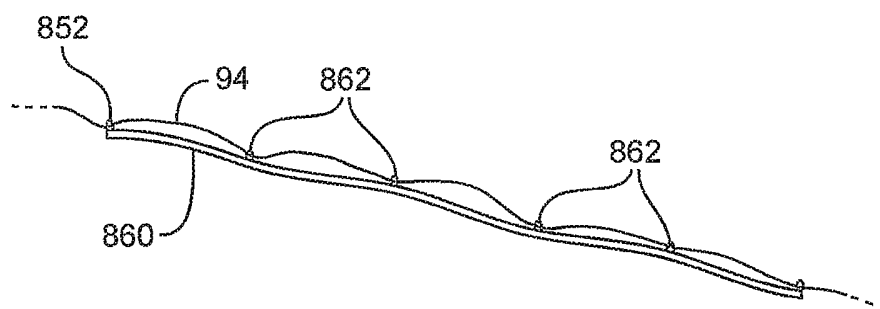

FIG. 47A

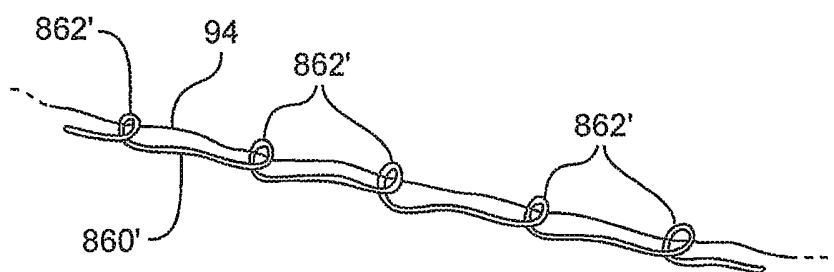

FIG. 47B

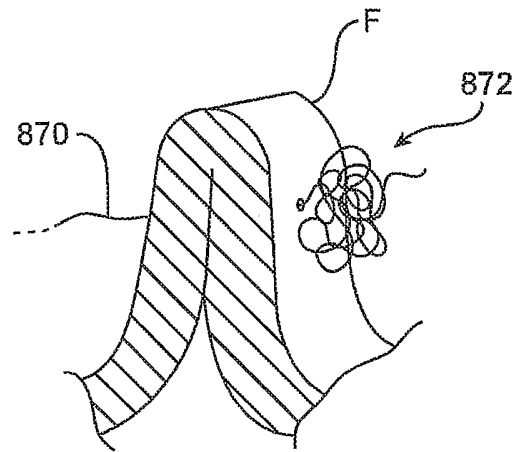

FIG. 48

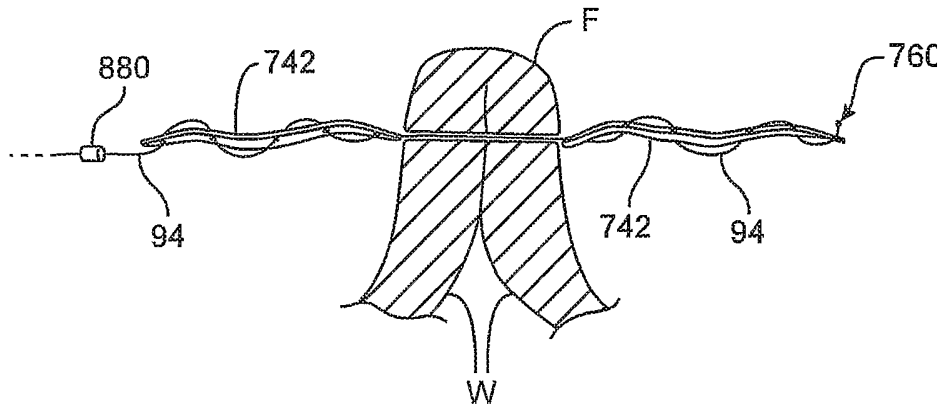

FIG. 49A

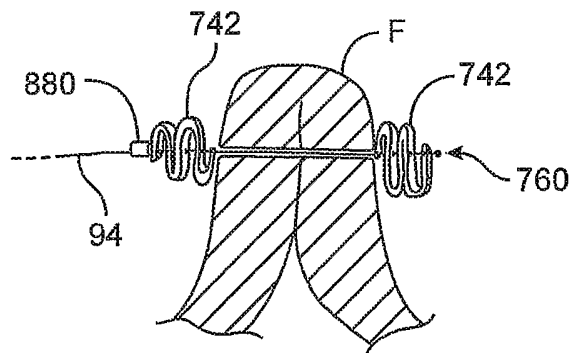

FIG. 49B

47/66

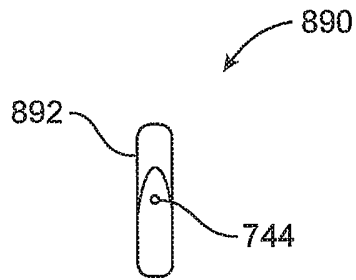

FIG. 50A

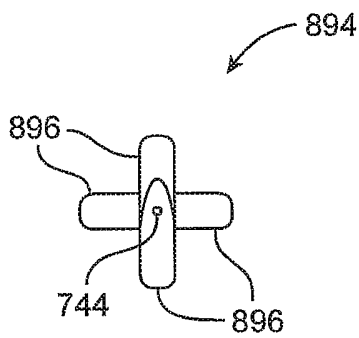

FIG. 50B

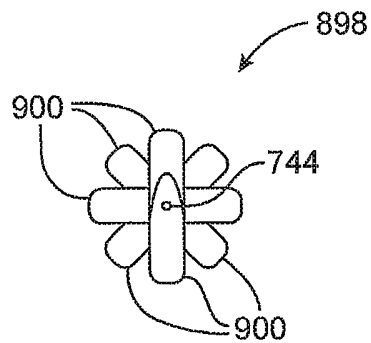

FIG. 50C

48/66

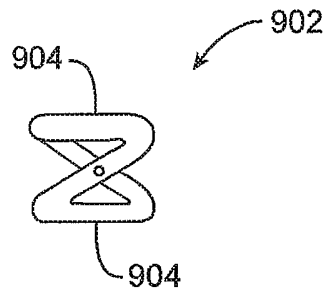

FIG. 50D

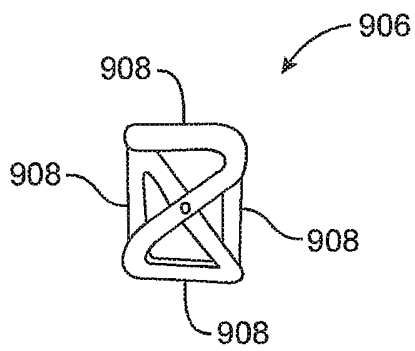

FIG. 50E

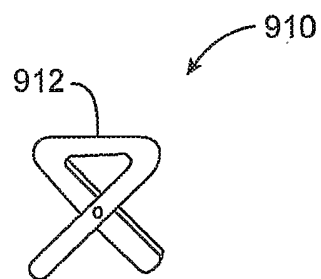
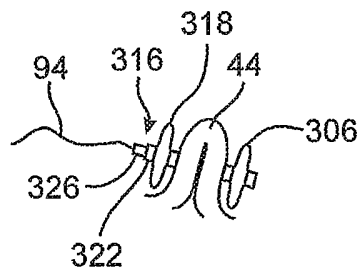
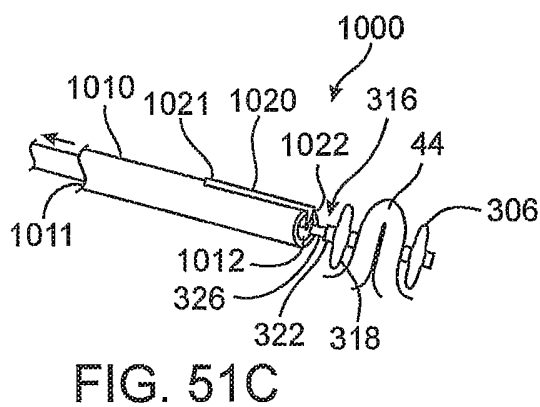
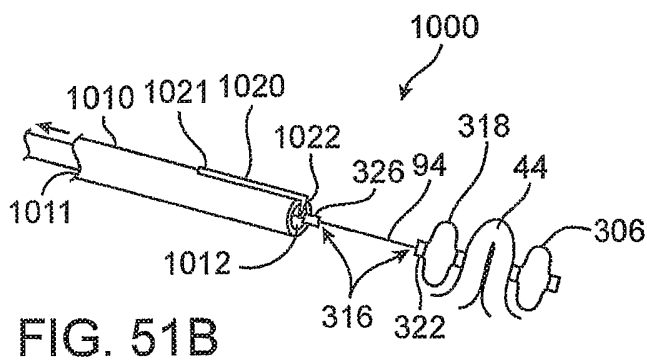
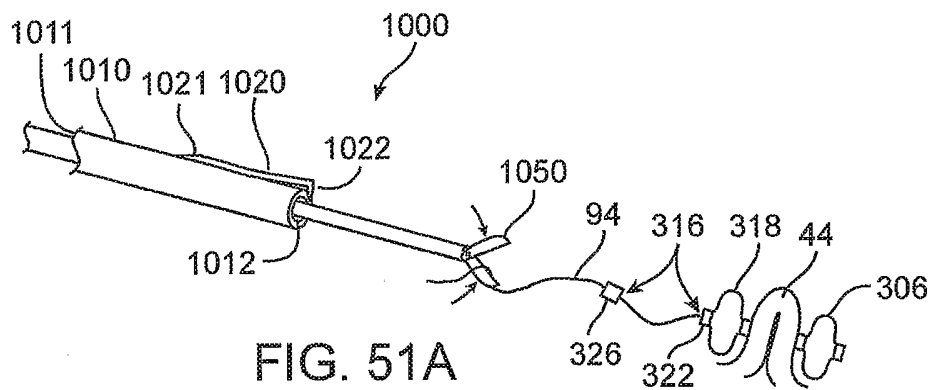

FIG. 50F

49/66



50/66

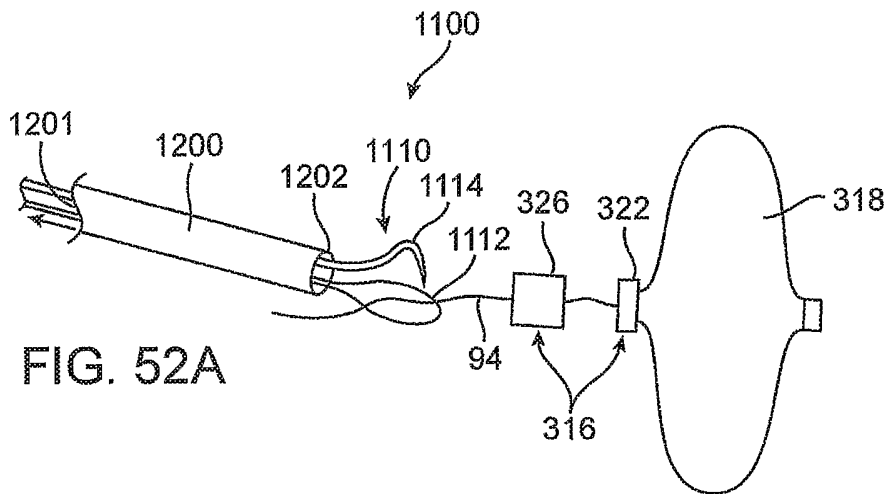

FIG. 52A

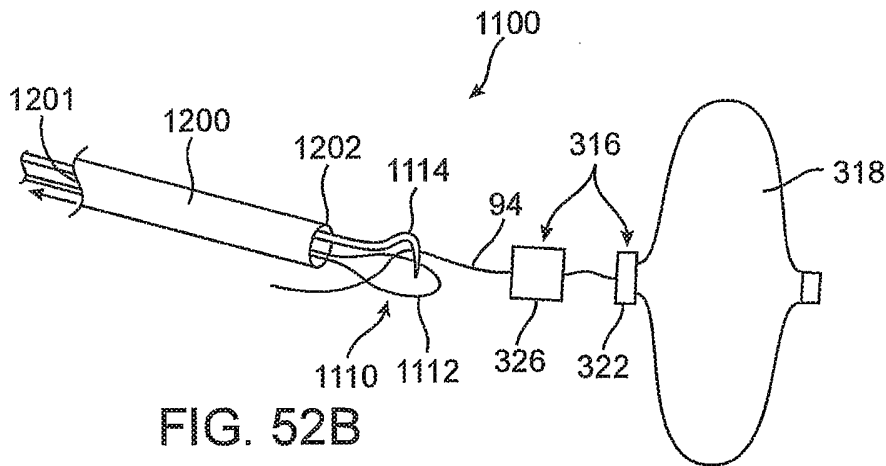

FIG. 52B

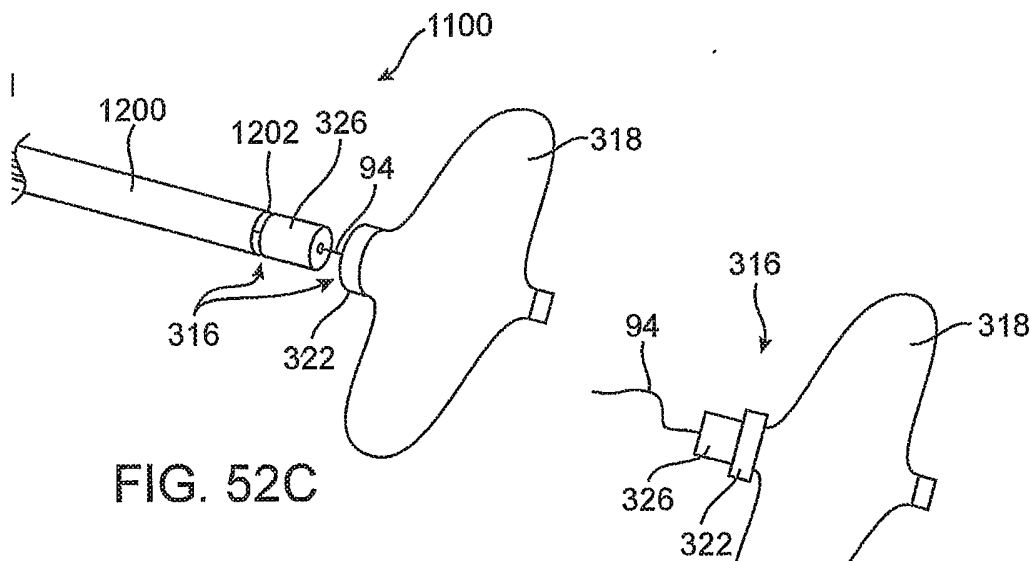

FIG. 52C

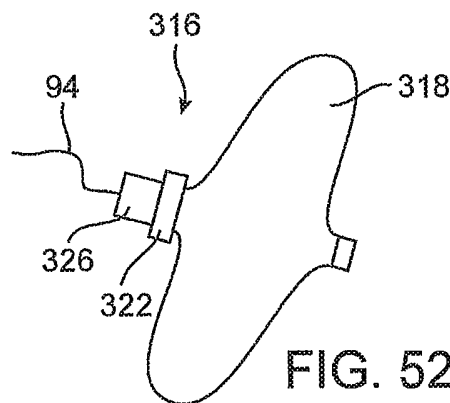

FIG. 52D

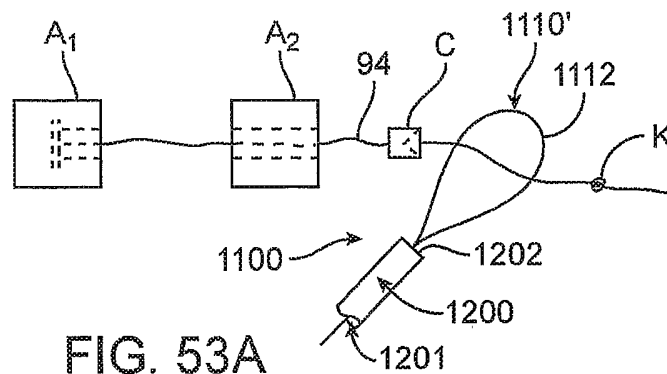

FIG. 53A

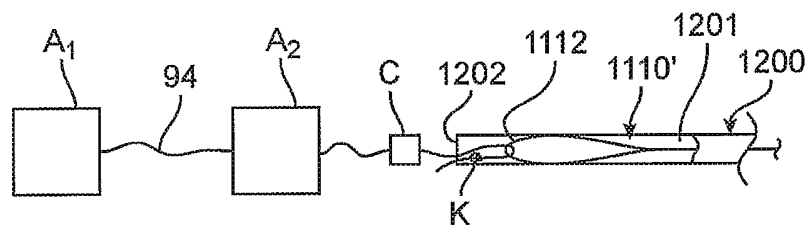

FIG. 53B

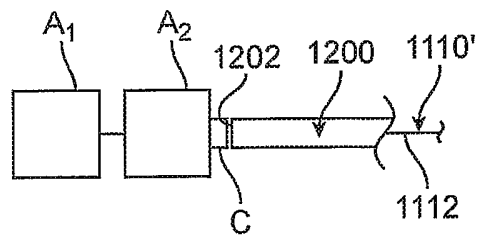

FIG. 53C

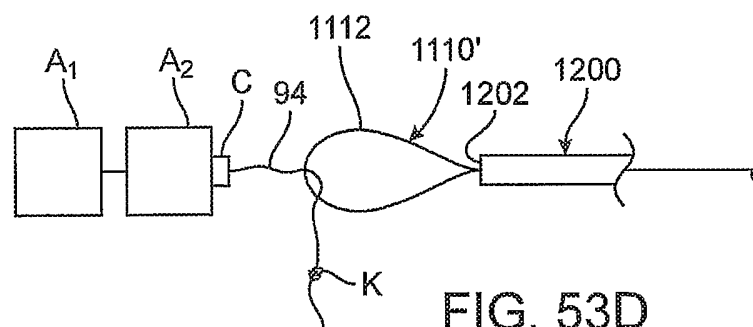

FIG. 53D

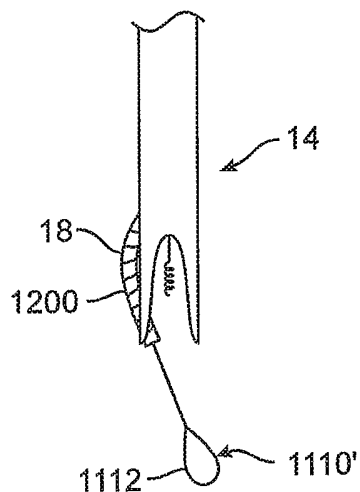

FIG. 54A

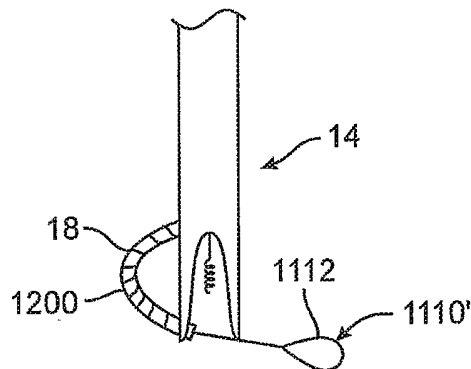

FIG. 54B

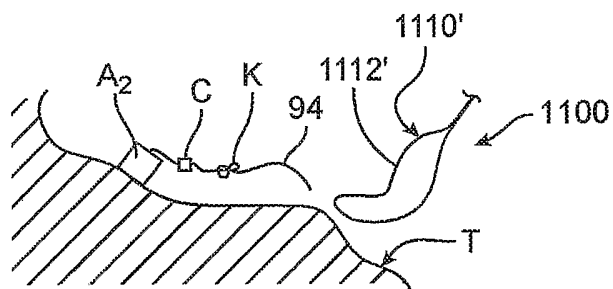

FIG. 55

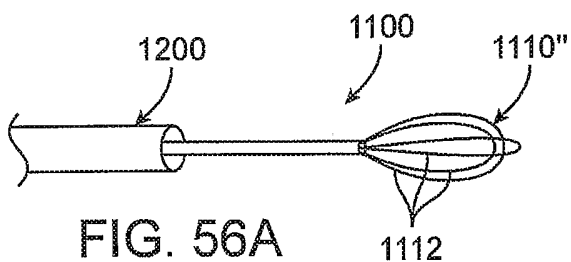

FIG. 56A

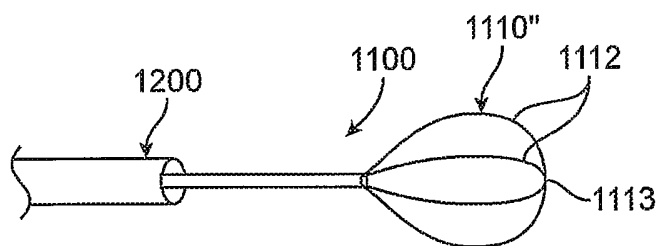

FIG. 56B

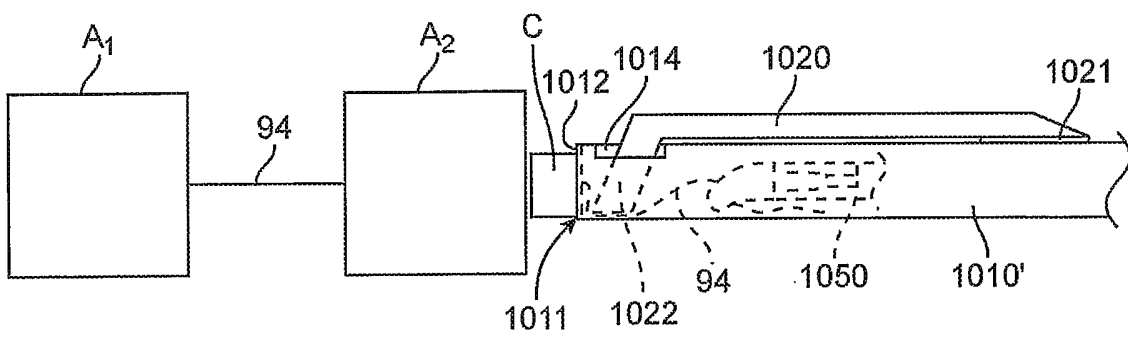
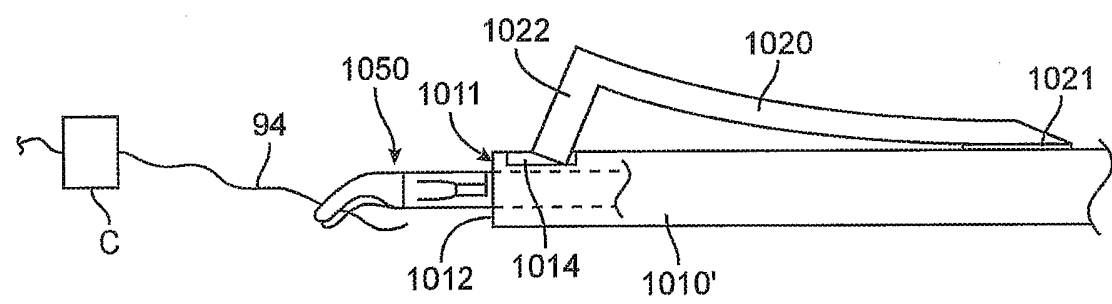
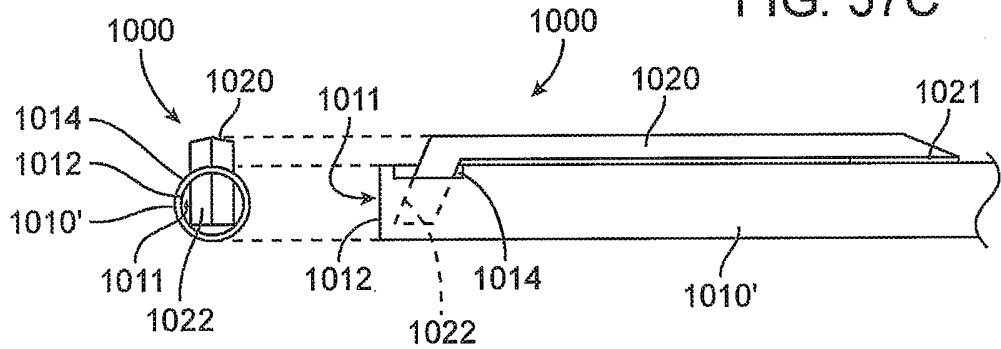
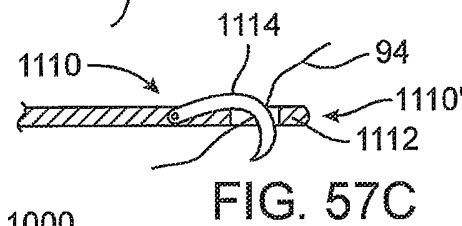
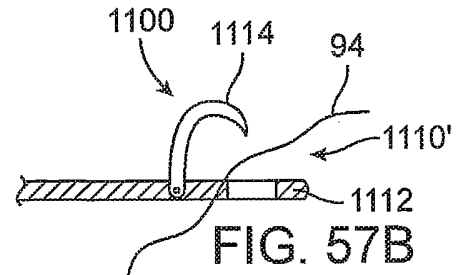
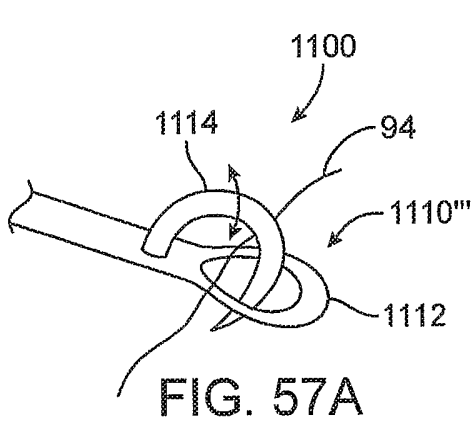

FIG. 57A

FIG. 57B

FIG. 57C

FIG. 58A

FIG. 58B

FIG. 58C

FIG. 58D

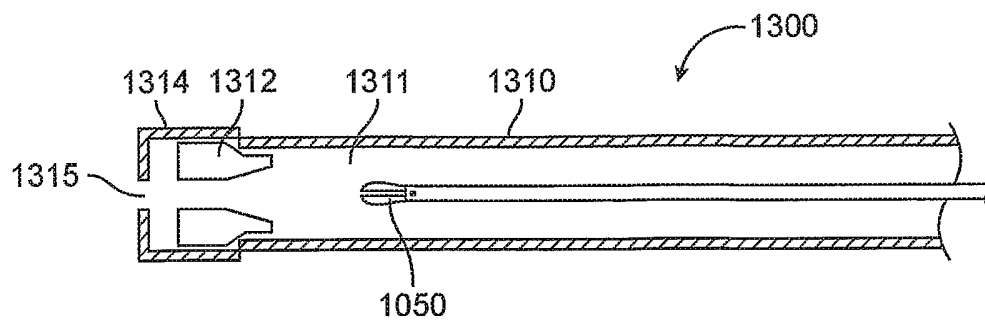

FIG. 59A

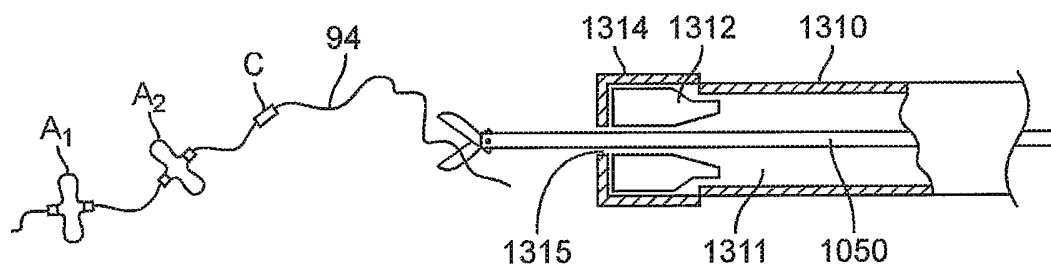

FIG. 59B

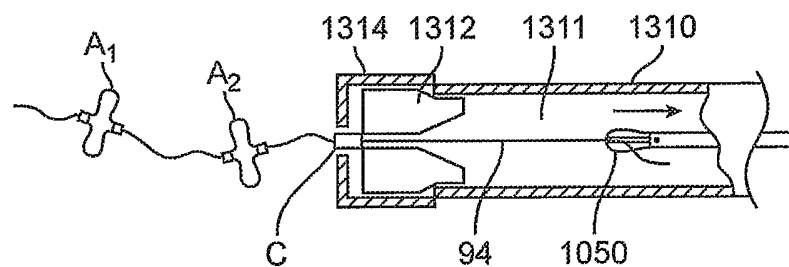

FIG. 59C

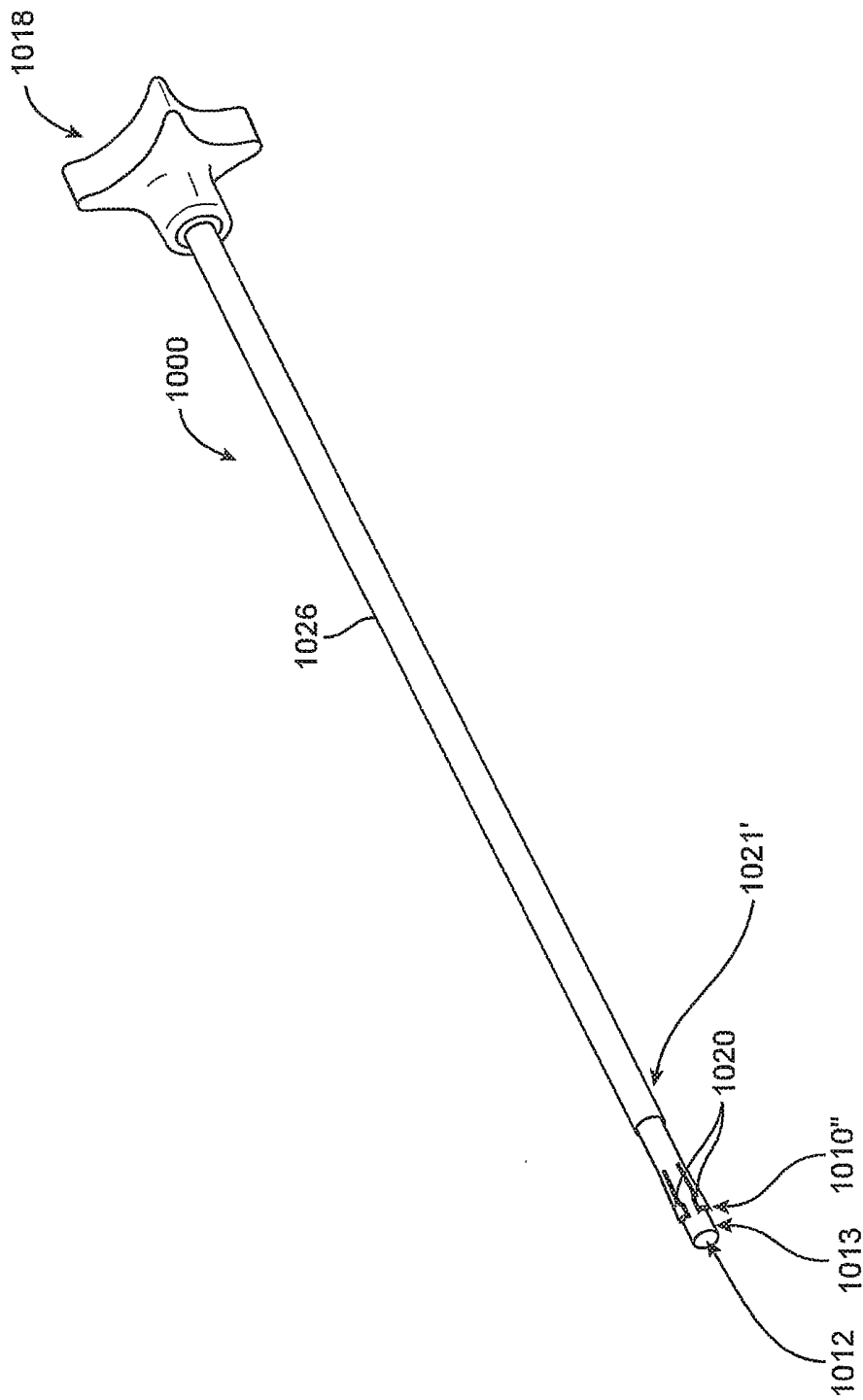

FIG. 60A

56/66

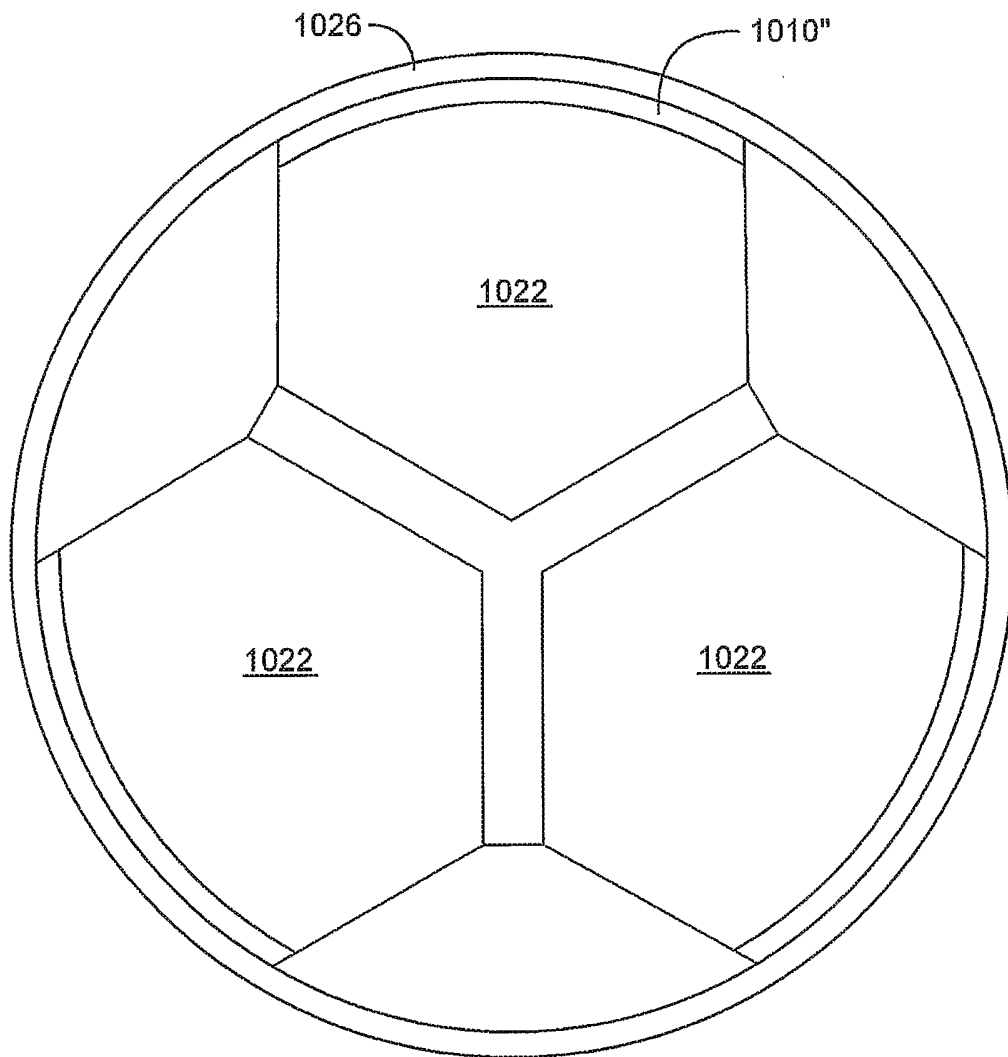

FIG. 60B

57/66

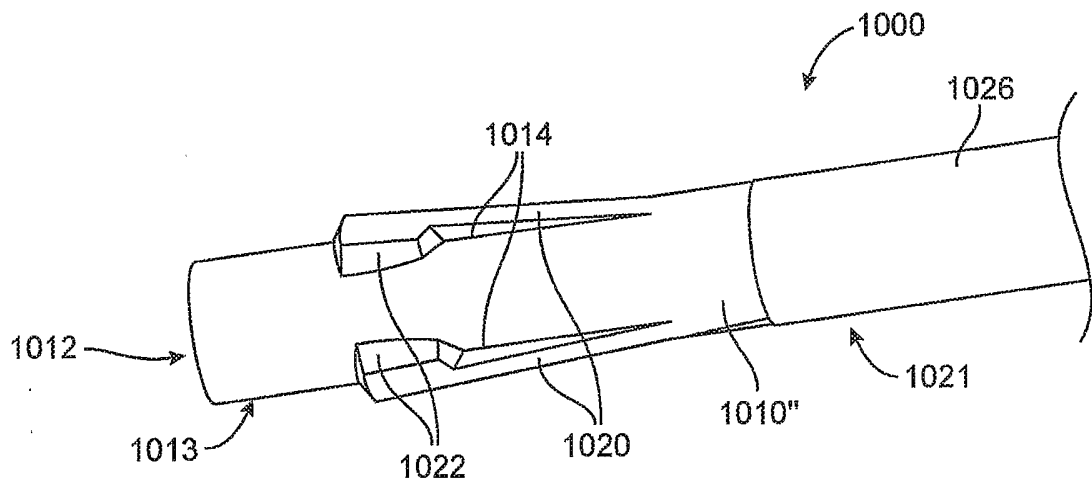

FIG. 60C

58/66

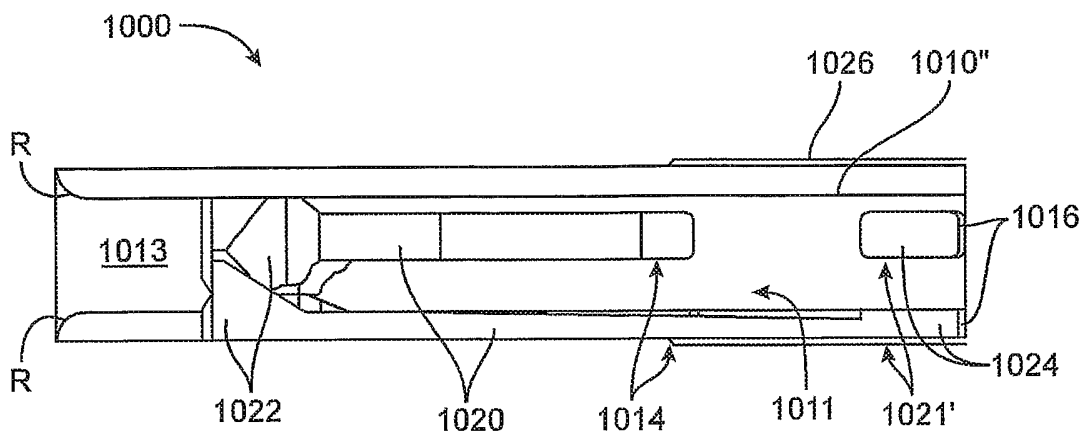

FIG. 60D

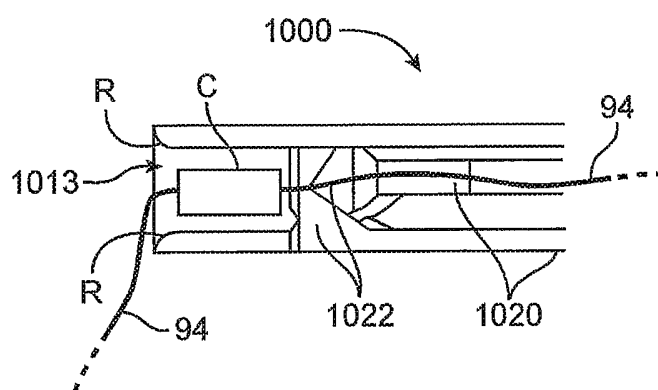

FIG. 60E

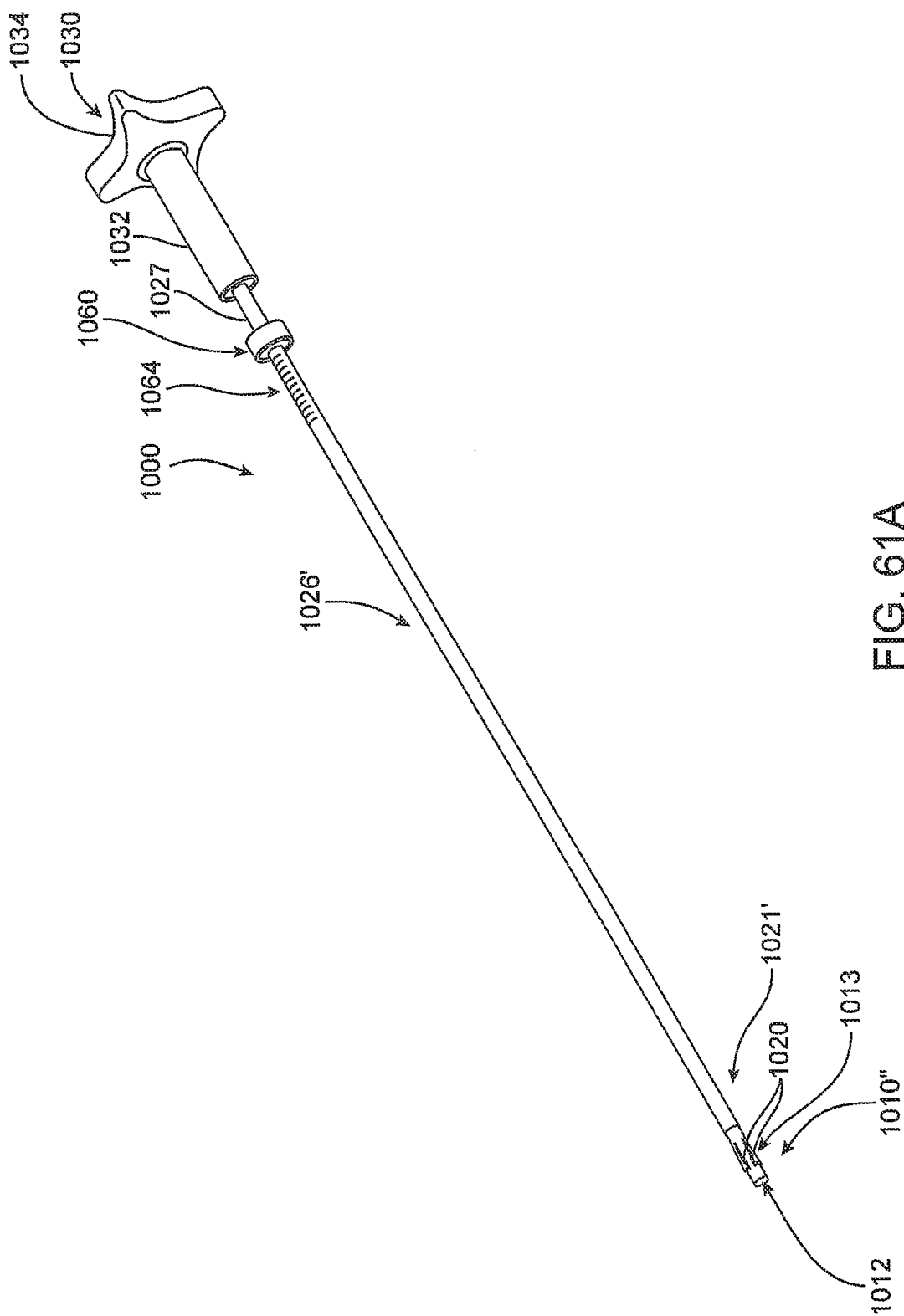

FIG. 61A

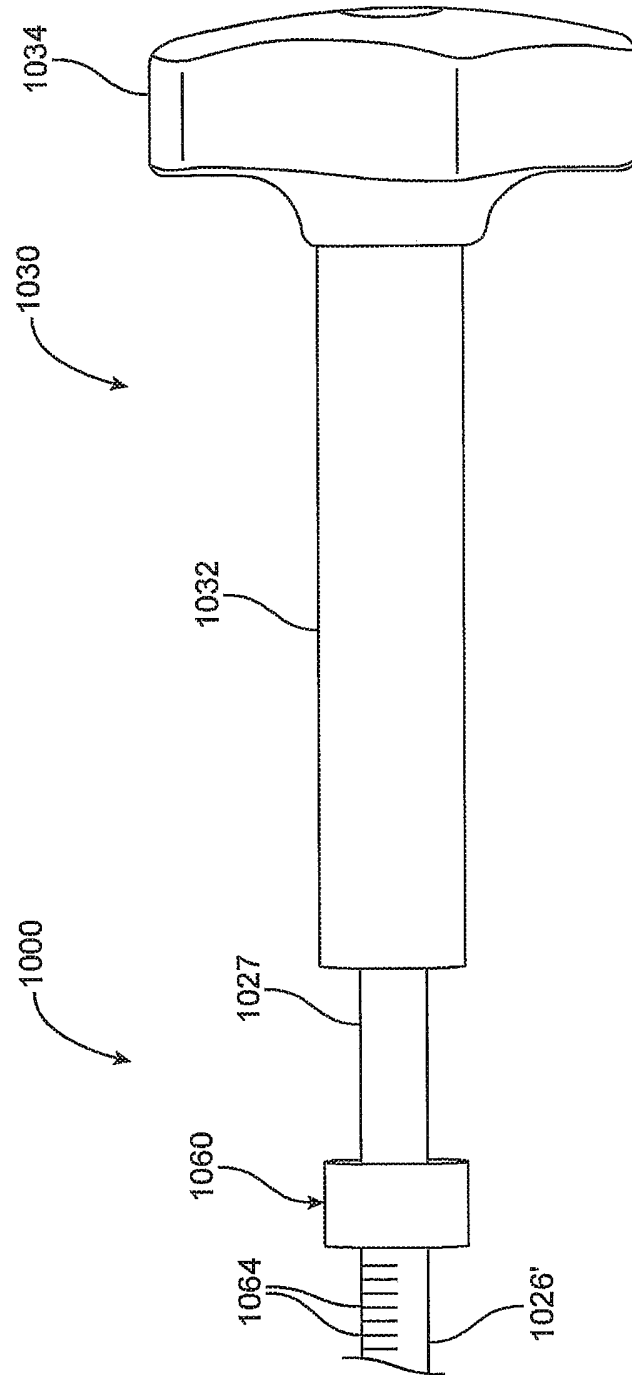

FIG. 61B

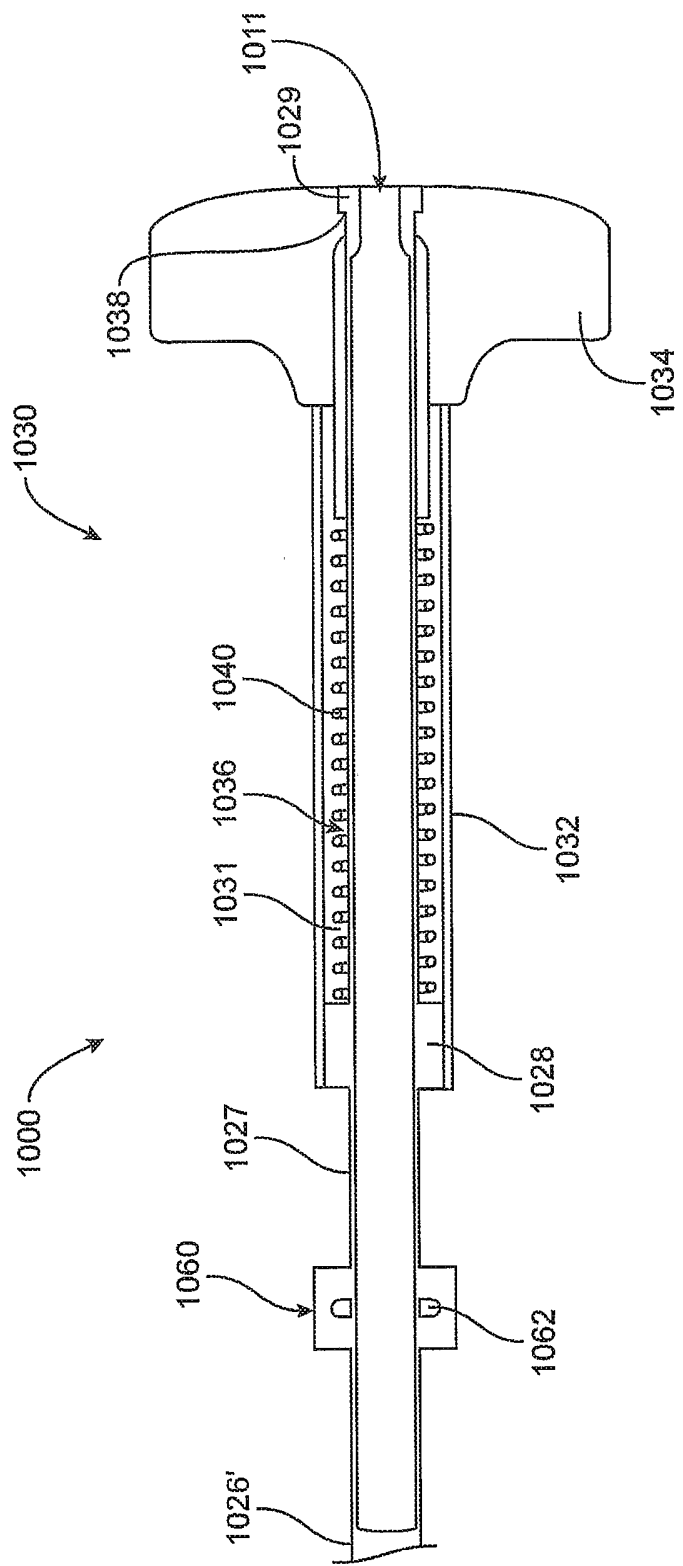

FIG. 61C

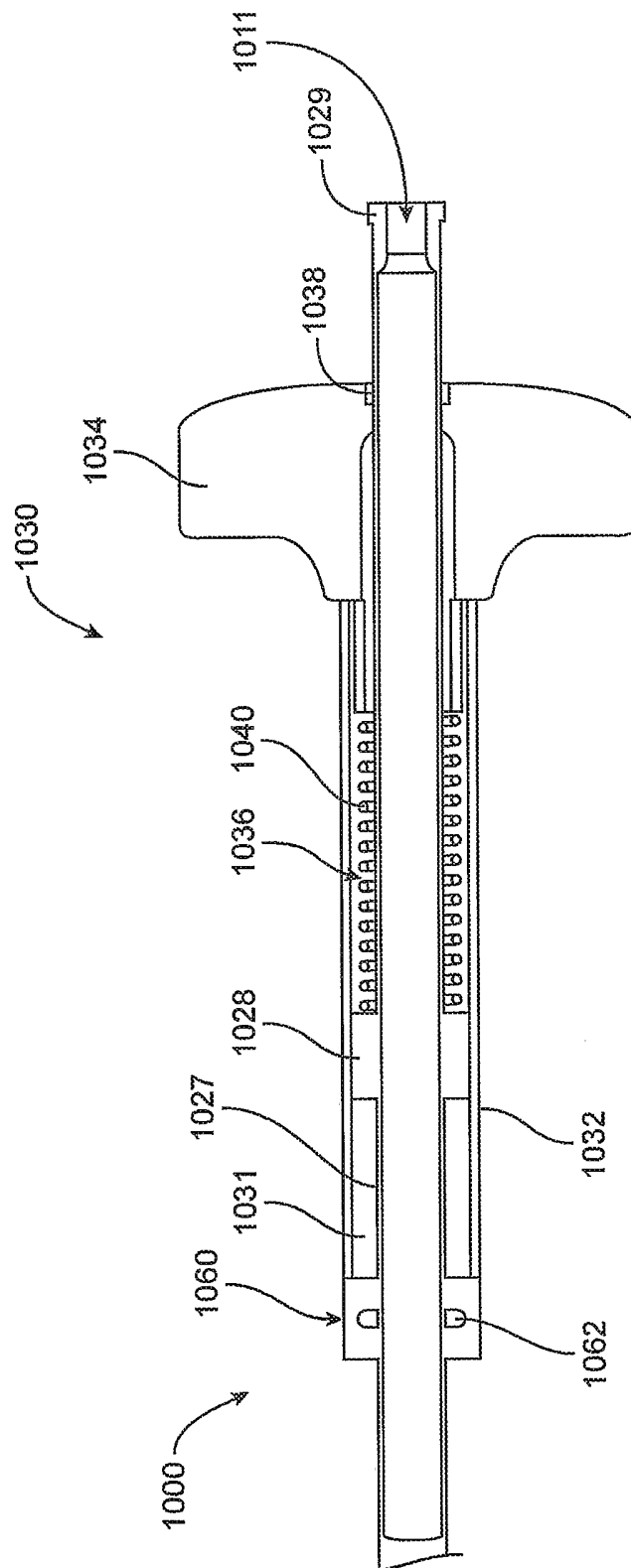

FIG. 61D

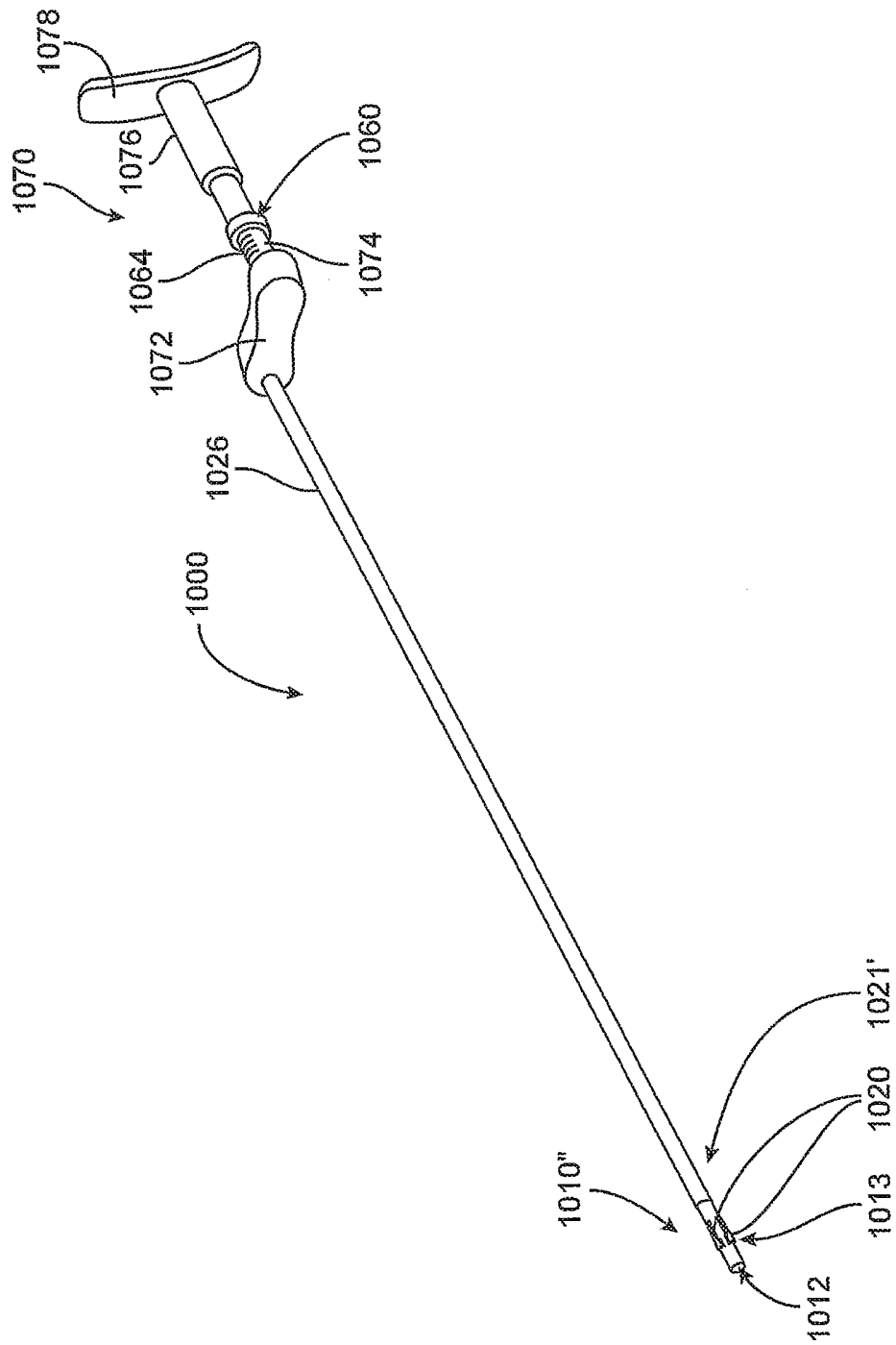

FIG. 62A

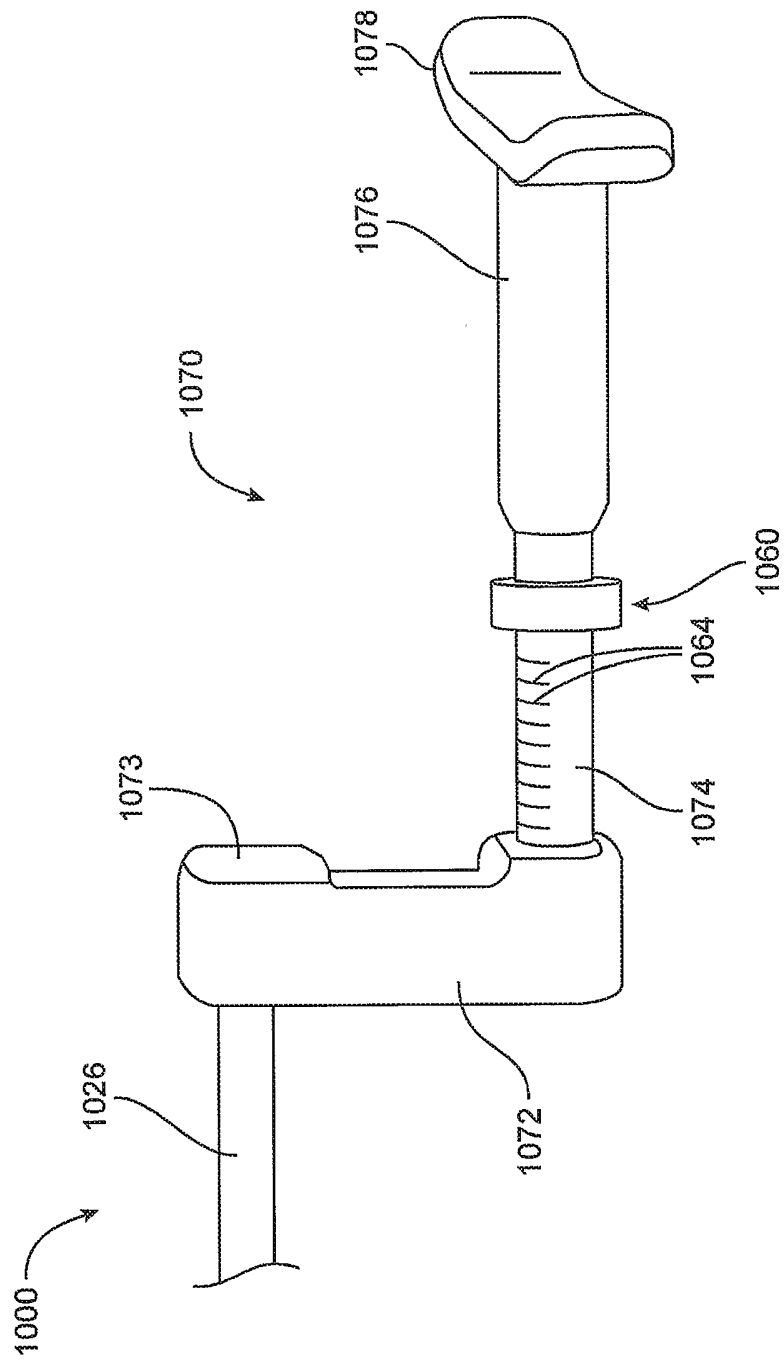

FIG. 62B

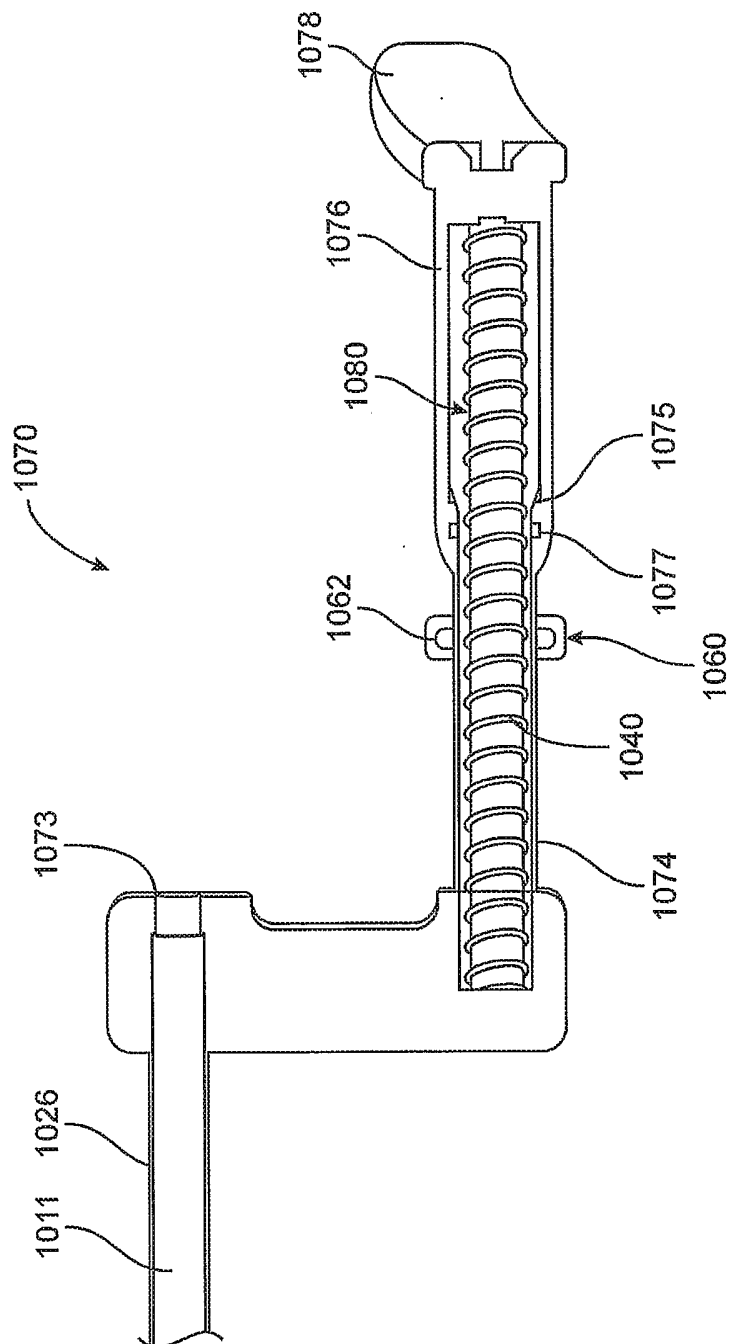

FIG. 62C

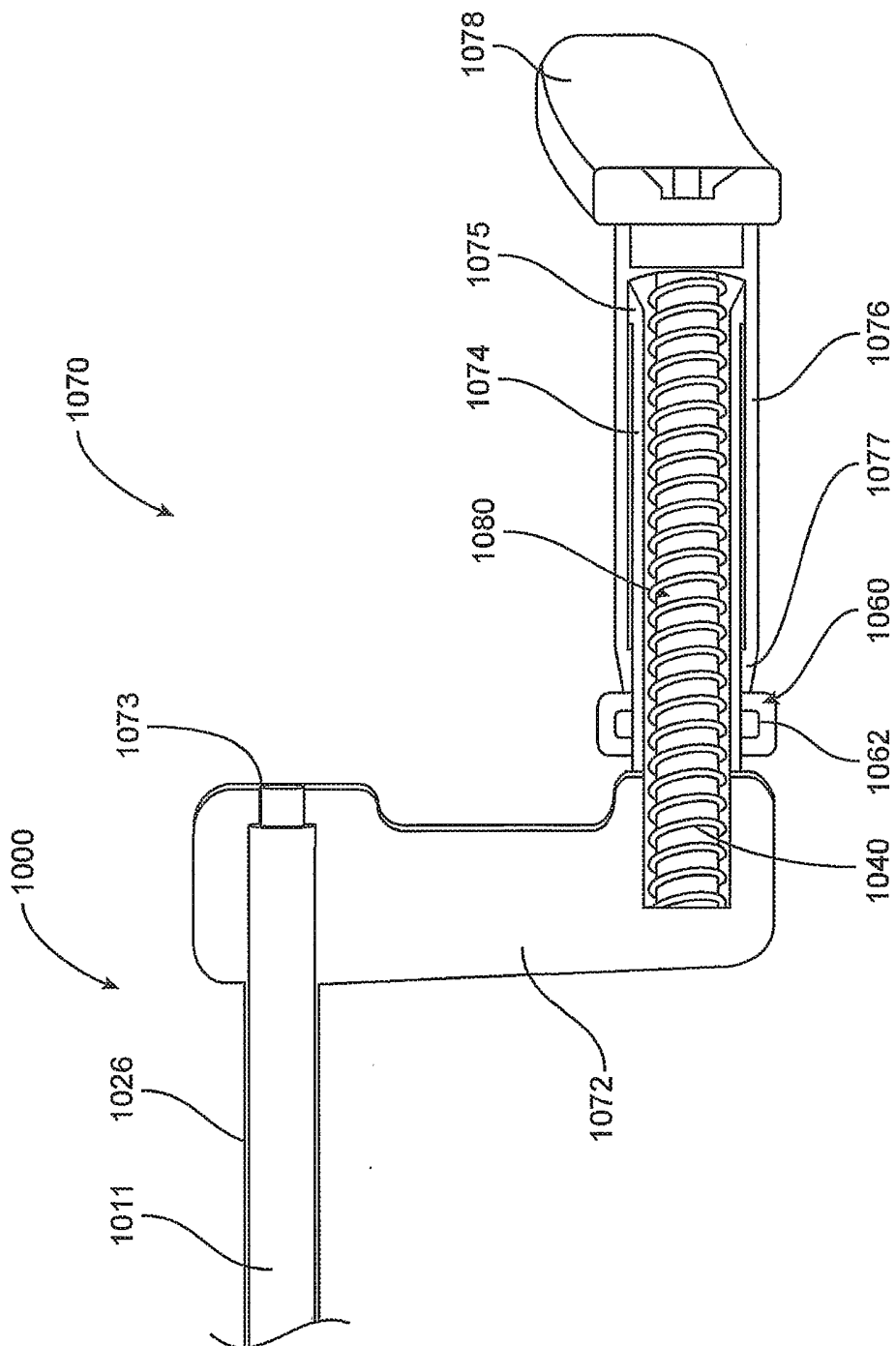

FIG. 62D