

(No Model.)

3 Sheets—Sheet 1.

D. C. & T. W. SAEMAN.
CONVEYING MACHINERY.

No. 523,083.

Patented July 17, 1894.

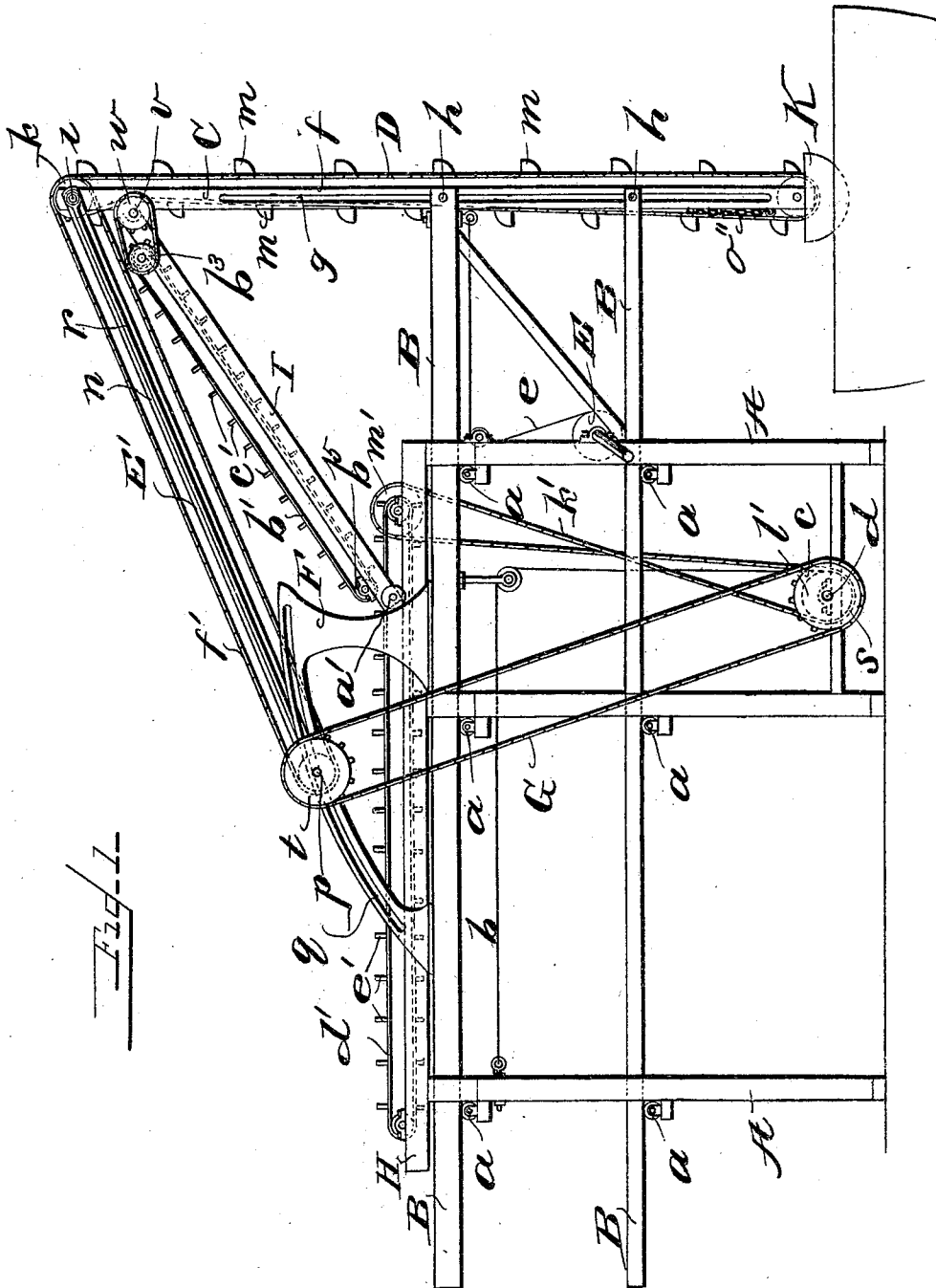

Fig. 1.

Witnesses
G. A. Tauberschmitt
M. A. Reinohl

Inventors
D. C. Saeman
T. W. Saeman
By D. E. Reinohl
Attorney

(No Model.)

3 Sheets—Sheet 3.

D. C. & T. W. SAEMAN.
CONVEYING MACHINERY.

No. 523,083.

Patented July 17, 1894.

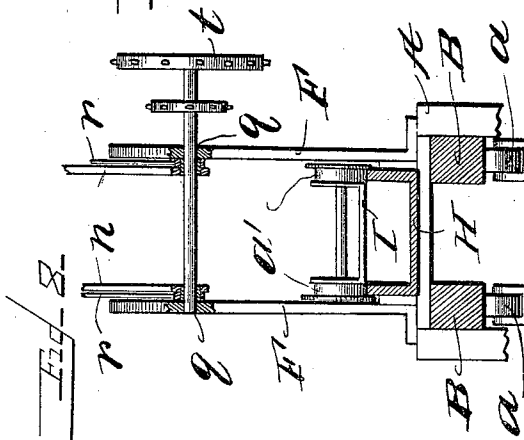
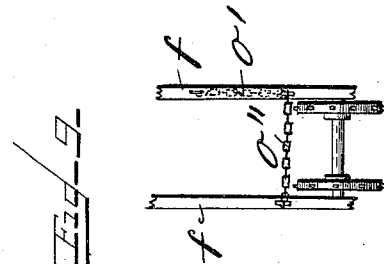
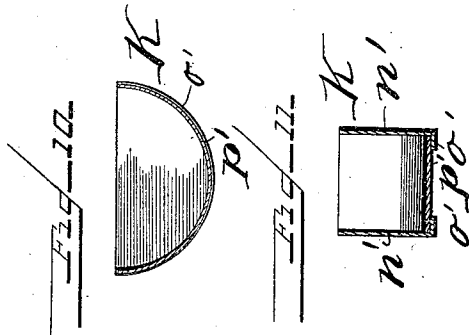
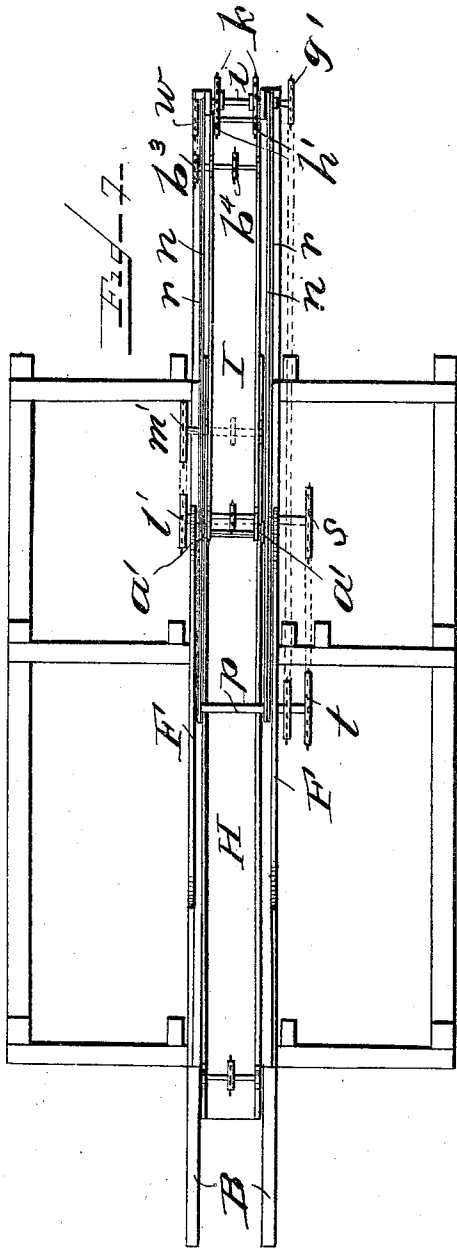

Witnesses
A. Tauberschmitt
M. A. Reinohl

Inventors
D. C. Saeman
T. W. Saeman
By D. C. Reinohl
Attorney

UNITED STATES PATENT OFFICE.

DANIEL C. SAEMAN AND THOMAS W. SAEMAN, OF PHILADELPHIA, PENNSYLVANIA, ASSIGNORS OF ONE-THIRD TO ABRAHAM C. SEAMAN, OF SAME PLACE.

CONVEYING MACHINERY.

SPECIFICATION forming part of Letters Patent No. 523,083, dated July 17, 1894.

Application filed November 20, 1893. Serial No. 491,502. (No model.)

To all whom it may concern:

Be it known that we, DANIEL C. SAEMAN and THOMAS W. SAEMAN, citizens of the United States, residing at Philadelphia, in the county of Philadelphia and State of Pennsylvania, have invented certain new and useful Improvements in Conveying Machinery; and we do hereby declare the following to be a full, clear, and exact description of the invention, such as will enable others skilled in the art to which it appertains to make and use the same.

Our present invention relates to conveying machinery and has especial reference to that class of conveying machinery used for unloading vessels such as schooners and canal and other boats laden with coal, sand and other like material capable of being taken up in elevator buckets and conveyed to some desirable place of deposit or storage.

The invention will be fully disclosed in the following specification and claims

In the accompanying drawings which form part of this specification Figure 1 represents a side elevation; Fig. 2 a front end elevation with the elevator chain and buckets removed; Fig. 3 an enlarged end view partly in section of the upper end of the elevator frame; Fig. 4 an enlarged side view of the upper end of the elevator frame, the inclined and horizontal conveyers; Fig. 5 a section on line, *ax* on Fig. 4; Fig. 6 a section on line *y, y*, on Fig. 4 showing the several sprocket wheels in elevation; Fig. 7 a top plan view of the entire mechanism with the elevator-chain and buckets removed; Fig. 8 an enlarged sectional detail showing the horizontal conveyer, the upper rails of the movable frame and their supports and the sprocket wheels at the inner end of the boom; Fig. 9 an inner end view of the lower end of the elevator frame; Fig. 10 a vertical longitudinal section of the boot at the lower end of the conveyer frame, and Fig. 11 a transverse section of the same.

Reference being had to the drawings and the letters thereon A indicates the main stationary frame, B a longitudinally movable frame supported upon suitable rollers *a* and is designed to be moved out and in with reference to the main frame to place the elevator-frame C and the elevator D in proper

position for unloading vessels of different widths.

The frame B may be moved out by a cable or rope *b* connected to an eye-bolt in the rear end of the frame at one end and a drum *c* on the main shaft *d* which may be connected with an engine or any suitable source of power, and be moved in by a cable or rope *e* engaging the front end of the frame at one end and a windlass E at the other end, or it may be moved by any suitable means which will be readily suggested by the skilled mechanic.

The sides *f* of the elevator-frame are slotted at *g* and engage transverse pins *h* in the frame B by which the two are secured together, and at the upper end of the elevator-frame it is connected to the boom E' by the shaft *i* which supports the sprocket-wheels *k* upon which the elevator-chain *l* is supported, and said elevator is provided with buckets *m* of the usual form.

The elevator-frame and the elevator-chain descend automatically by gravity as the material is removed from the vessel to keep the lower end of the frame and the buckets of the elevator in contact with the material to be removed.

The sides *n n* of the boom E' at their front ends engage the shaft *i* with a thimble or sleeve *o* interposed to avoid wear, see Fig. 3, and at their rear ends they engage the shaft *p* which passes through the sector shaped slots *q q* in the brackets F supported on the upper timber of the stationary frame A, and on the outside of each of the sides *n n* are metal rods *r r* which also engage the shafts *i* and *p* and stiffen the boom.

The brackets F may be bolted to the sides of the upper timber of the frame or they may be provided with a right angled flange and be bolted to the upper edge of said timber.

As the elevator-frame C and the front end of the boom E' rise and fall, the rear end of the boom swings vertically upon the shaft *p*, and as the frame B is moved out or in with relation to the fixed frame A, the rear end of the boom travels back and forward in the slots *q q* in the brackets F and thereby keep the driving belt G taut between the pulley *s*

on the main shaft and the pulley *t* on the shaft *p*.

H indicates a horizontal and fixed or stationary conveyer which rests upon the frame A, and I an inclined and movable conveyer the sides *u u* of which at their front and upper end are pivotally connected to the shaft *v* which supports the pulley *w*, and the rear end of said conveyer is supported upon the stationary conveyer H by wheels *a' a'*, (see Figs. 4 and 5) which travel back and forward on the upper edge of the sides of the stationary conveyer as the elevator-frame and the front end of the boom rise and fall.

The conveyer I is provided with an endless belt or apron *b'* on which are arms or blades *c'* to draw the material down toward and into the stationary conveyer H, which is provided with a like constructed belt or apron *d'* having arms or blades *e'* which draw the material to the rear end of the conveyer from which it may fall upon the ground or it may be conducted to any desired place of deposit.

The belt *f'* transmits motion to the elevator-chain *l* by engaging the pulley *g'* on the shaft *i*; and the chain *l* engaging the sprocket wheel *h'* on the shaft *v* transmits motion to the belt or apron *b'* through belt *b²* and pulleys *b³*, *b⁴* and *b⁵*; and the belt *h'* which engages the pulley *l'* on the main shaft also engages the pulley *m'* and transmits motion to the belt or apron *d'* in the stationary conveyer H.

The lower end of the elevator-frame C is provided with a boot K into which the material to be unloaded is shoveled when the bottom of the vessel has been reached and from which the buckets *m* are then filled. The boot comprises two sides *n' n'* having inwardly bent flanges *o' o'* and a separate bottom *p'* which can be readily inserted between the sides *n' n'* when the boot is required, and as readily removed when its use is no longer necessary. The sides *n'* may be detachably secured to the sides *f* of the elevator-frame by any suitable means.

When the bottom of the vessel has been reached and all the material removed from one compartment or within easy reach of the elevator, the frame C and the elevator-chain *l* are raised out of the hatch of the vessel by means of any suitable hoisting mechanism such as the main shaft *d* or by the windlass E to which a cable or rope (not shown) may be attached and secured to the lower end of the frame, for which purpose we have provided a chain *o''* for the cable or rope to engage. This hoisting rope being of well known construction has been omitted from the drawings to avoid confusion.

The material raised by the chain *l* and buckets *m* is discharged into the inclined conveyer I, from which it falls into the horizontal conveyer H and is conveyed to the end of the structure.

Having thus fully described our invention, what we claim is—

1. In a conveying machine, a stationary

supporting frame, a longitudinally movable and self adjusting-frame pivotally and slidably attached at its inner end to said supporting-frame, and an elevator-frame pivotally attached at its upper end to the outer end of said self adjusting-frame; in combination with drive mechanism supported by said self adjusting-frame and suitable elevating mechanism. 70

2. In a conveying machine, a stationary supporting-frame, a vertically and longitudinally movable self adjusting-frame, pivotally and slidably attached at its inner end to said supporting-frame, and a vertically movable elevator-frame pivotally attached at its upper end to the outer end of said self adjusting-frame; in combination with drive mechanism supported on the self adjusting-frame, and an endless elevator. 85

3. In a conveying machine, a stationary supporting-frame, a vertically and longitudinally movable self adjusting-frame pivotally connected at its inner end to said supporting-frame, an elevator-frame pivotally connected to the outer end of said self adjusting-frame and provided with elevating mechanism, and a longitudinally movable and inclined conveyer under the self adjusting-frame and connected to the elevator-frame; in combination with drive mechanism supported by said self adjusting frame and a horizontal conveyer supported by the main frame. 95

4. In a conveying machine, a stationary supporting-frame, a movable frame between the vertical timbers of and extensible beyond said supporting-frame, and a vertically adjustable elevator-frame secured to said movable-frame; in combination with a self adjusting-frame connected to said movable-frame, drive mechanism supported by the self adjusting-frame, and suitable elevating mechanism. 105

5. In a conveying machine, a stationary supporting-frame, a movable frame within and extensible beyond said stationary frame, a vertically and longitudinally movable and self adjusting-frame pivotally connected to the supporting-frame, and a vertically adjustable elevator-frame secured to said movable frame, in combination with drive mechanism supported by the self adjusting-frame and suitable vertical and horizontal conveying mechanism. 120

6. In a conveying machine, a stationary supporting-frame, a vertically movable elevator-frame, a self adjusting-frame pivotally connected at one end to said elevator-frame and brackets having slots concentric to the power-wheel in which the opposite end of said self adjusting-frame is supported; in combination with driving mechanism supported by the self adjusting-frame and suitable conveying mechanism. 125

7. In a conveying machine, a stationary supporting-frame, a vertically movable elevator-frame, a vertically movable self adjusting-frame, pivotally connected to said ele- 130

vator-frame at one end, brackets having curved slots concentric to the power-wheel, and means for connecting the self adjusting-frame to said brackets, in combination with
 5 drive mechanism supported by the self adjusting-frame and conveying mechanism.

8. In a conveying machine, a stationary supporting-frame, a longitudinally movable frame within and extensible beyond said stationary-frame, a self adjusting-frame, an elevator-frame pivotally connected to the self
 10 adjusting-frame, drive mechanism on the self adjusting-frame, and a vertical elevating mechanism connected to said movable frame;
 15 in combination with an inclined and horizontal conveyer.

9. In a conveying machine, a stationary

supporting frame and a frame within and extensible beyond the stationary frame, a self
 20 adjusting-frame supporting the drive mechanism, a vertical elevating mechanism connected to said extensible frame and to the self adjusting-frame, and a stationary horizontal conveyer frame; in combination with
 25 a vertically and longitudinally movable conveyer frame above the main supporting-frame, and suitable conveyers.

In testimony whereof we affix our signatures in presence of two witnesses.

DANIEL C. SAEMAN,
 THOMAS W. SAEMAN.

Witnesses:

JOHN SHAFFNER,
 THOS. R. MUNDSELELE.