

[54] **INFLATING APPARATUS**

[72] Inventor: **Lyle D. Galbraith**, Redmond, Wash.

[73] Assignee: **Rocket Research Corporation**,
Redmond, Wash.

[22] Filed: **March 16, 1971**

[21] Appl. No.: **124,887**

[52] U.S. Cl.**417/184, 417/191, 417/179**

[51] Int. Cl.**F04f 5/48**

[58] Field of Search.....**417/184, 171**

[56] **References Cited**

UNITED STATES PATENTS

3,598,504	8/1971	Siravo.....	417/184
3,338,269	8/1967	Zilka et al.....	137/604
3,158,314	11/1964	Young et al.	417/191 X
3,572,974	3/1971	Day	417/179
3,591,314	7/1971	Day	417/179

Primary Examiner—William L. Freeh
Assistant Examiner—Richard E. Gluck
Attorney—Graybeal, Cole & Barnard

[57] **ABSTRACT**

An inflating apparatus utilizing aspirating air from a compressed gas source and aspirated ambient air to inflate a life raft, escape slide, bag or other inflatable. There is an axially translating aspirating tube having a forward position in which ambient air is aspirated through a housing laterally into the tube by means of pressurized gas entering the tube through nozzles positioned behind the tube. The tube is held in this forward position by a locating piston responsive to pressure from the compressed air source, and there is in the piston a spring to urge the tube rearwardly. As pressure in the inflatable increases and pressure from the compressed air source declines, the tube by action of an annular back pressure diaphragm and the spring, translates rearwardly to reduce the aspirated air inlet area until the tube bears against a back closure plate so as to act as a closure valve.

22 Claims, 4 Drawing Figures

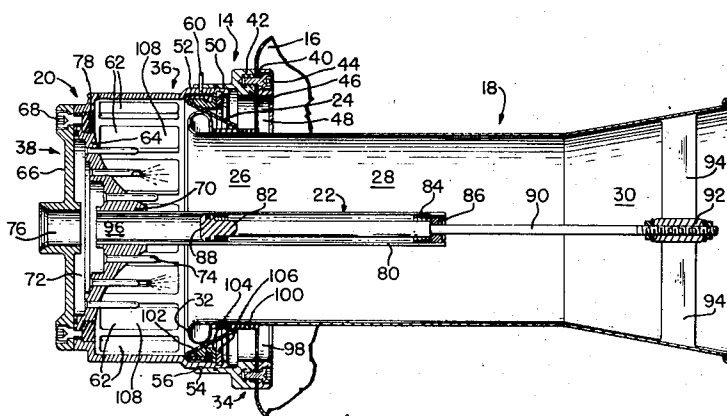

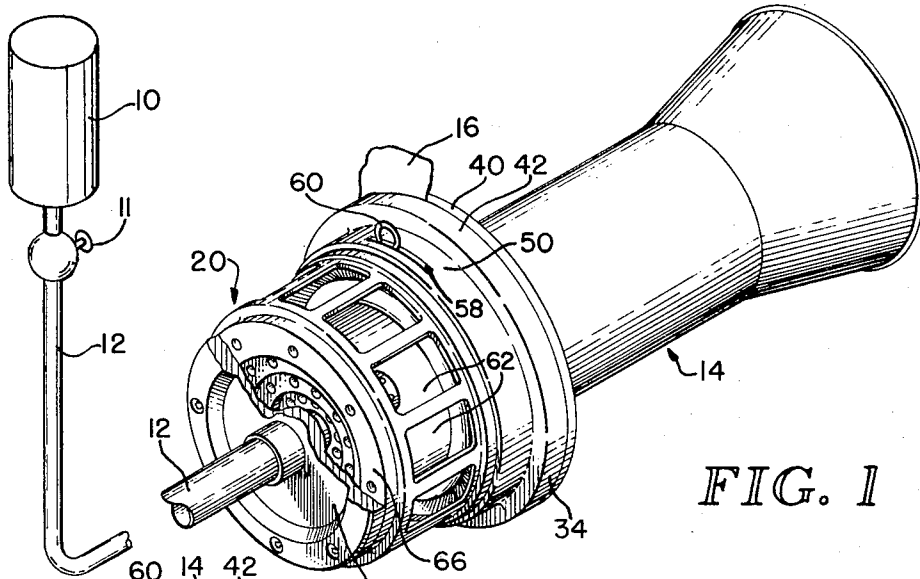

FIG. 1

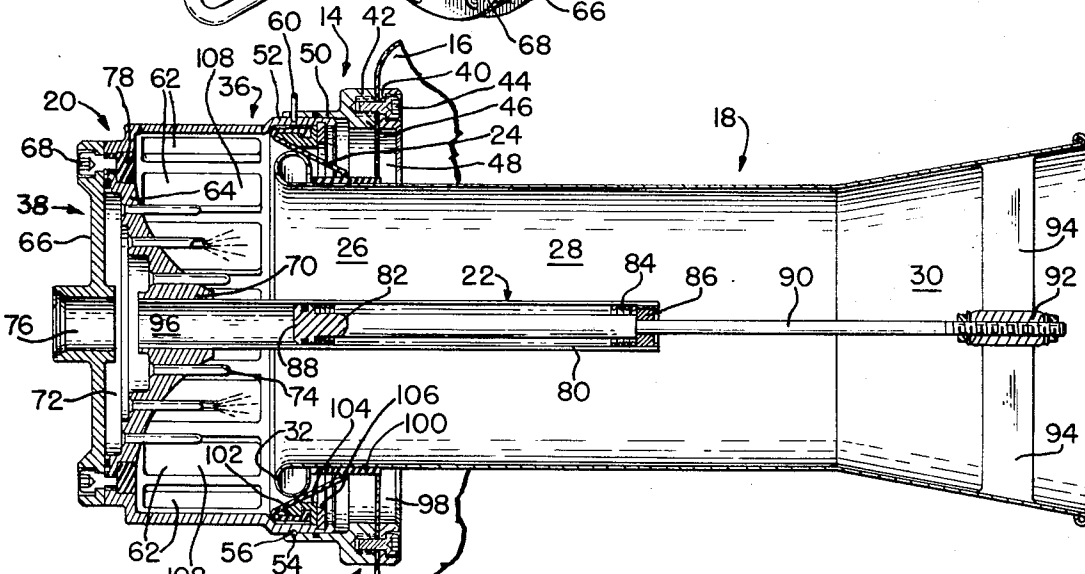

FIG. 2

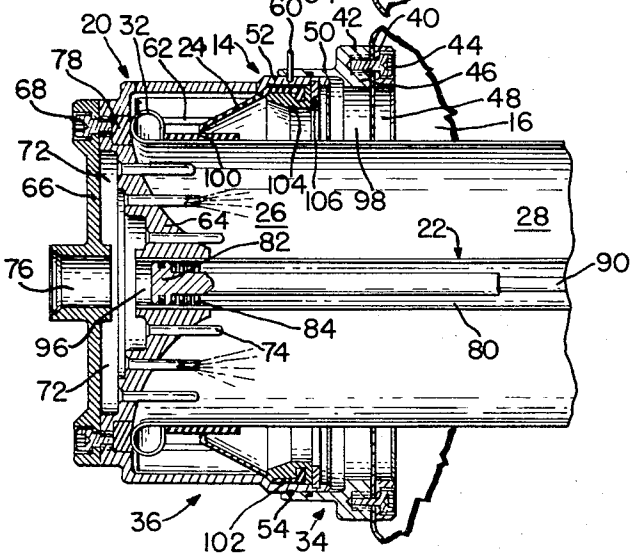

FIG. 3

INVENTOR,
LYLE D. GALBRAITH

BY

Graybeal, Cole & Barnard

ATTORNEYS

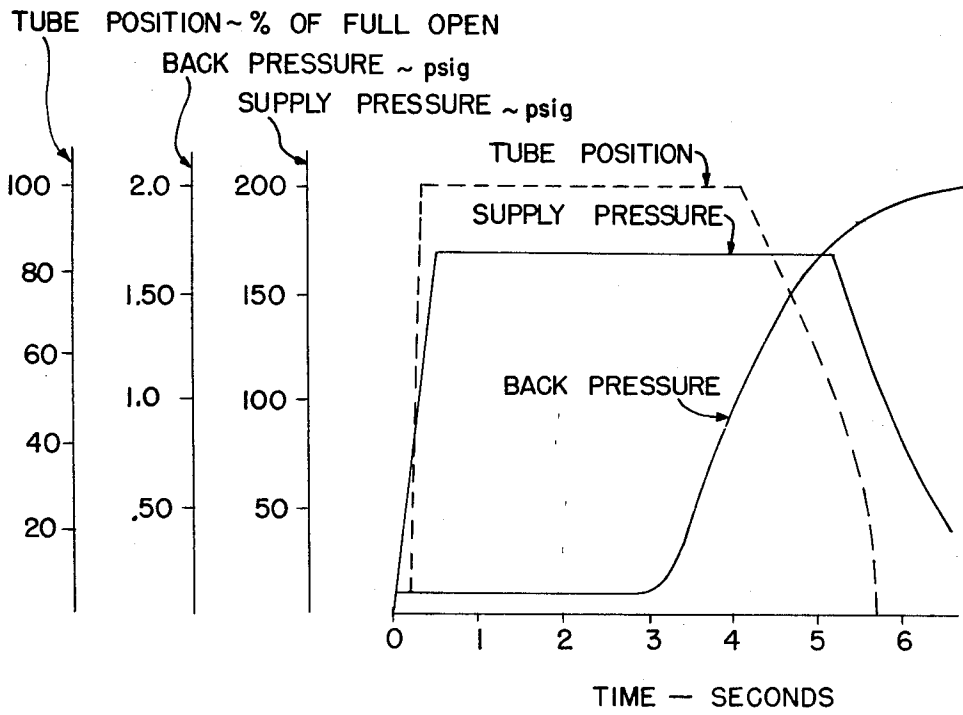

FIG. 4

INVENTOR
LYLE D. GALBRAITH

BY
Gregory, Cole & Barnard
ATTORNEYS

INFLATING APPARATUS

BACKGROUND OF THE INVENTION

1. Field of the Invention

This invention relates to inflating apparatus for a bag or other inflatable, where the apparatus has primary or aspirating fluid and aspirated fluid which combine to provide the inflating fluid mixture.

2. Description of the Prior Art

There are various devices in the prior art which provide a primary or aspirating fluid which draws in aspirated air to provide an inflating gas mixture. To close the inflatable after inflation some of these devices have check valve means responsive to back pressure in the inflated bag or other inflated device to close off the inflating passageway. However, some of these devices have been unduly complex, and others have not provided for secure closure after inflation. The result has been that when such inflating devices have been used, for example, in an inflatable life raft, the closure will open momentarily under jostling or surges of pressure from wave action to permit water to leak into the inflated life raft.

As examples of the prior art, U.S. Pat. No. 2,975,958 shows an aspirating nozzle, an aspirating tube, and a spring loaded closure valve at the exit end of the aspirating tube. When the inflating pressure drops to a predetermined level, the back pressure in the inflated bag and the biasing spring close the valve element.

U.S. Pat. No. 3,056,540 shows an aspirating passageway with two flap valves, the first at the exit of the aspirating tube. When the inflating pressure drops to a predetermined level, the back pressure in the inflated bag and the biasing spring close the valve element.

U.S. Pat. No. 3,056,540 shows an aspirating passageway with two flap valves, the first at the exit of the aspirating tube and the second at the entrance. When the back pressure in the inflated bag reaches a predetermined level, it closes the valve at the outlet of the aspirating tube. Pressure builds up in the tube to close the second valve and shut off aspirating air. Thus pressure in the aspirating tube builds up again and opens the first valve at the exit end of the aspirating tube to further inflate the bag or other inflatable device.

U.S. Pat. No. 3,338,266 provides a poppet-type valve at the exit end of the aspirating tube. Pressure from the aspirating fluid operates on a piston to open the valve. As the pressure of the aspirating fluid declines, the poppet valve moves toward a closure position, until it completely closes the outlet of the aspirating passageway. Pressurizing fluid then flows through a second passageway to further inflate the bag without any aspirating action.

It is believed that there exists in the prior art an inflating device manufactured by Pacific Inflatables Company of San Francisco, California, which utilizes an axially translating aspirating tube which moves rearwardly to close the aspirating passageways, but the applicant herein has no written reference material to cite relative to that device.

SUMMARY OF THE INVENTION

In the present invention there is a compressed gas source which operates through an aspirating inflating

apparatus to inflate a bag or other inflatable device. The aspirating apparatus comprises a support structure having forwardly directed primary or aspirating nozzles and ambient air inlets spaced laterally therefrom to permit the inflow of aspirated air. There is an aspirating tube forward of the primary nozzles and mounted for axial movement toward and away from the primary nozzles. When compressed gas is initially directed into the inflating apparatus, a positioning cylinder responsive to the gas pressure acts against the aspirating tube to move it to its furthest forward position to permit a maximum inflow of aspirated air. When the pressure from the compressed gas source declines and/or back pressure builds up in the inflated device, the aspirating tube, by action of a biasing spring acting against the positioning cylinder and by action of a back pressure diaphragm connected to the tube, is caused to move back toward a closure plate, thus reducing the flow of aspirated air. Finally, the tube moves against the closure plate to completely seal off the flow of aspirated air and close the inlet opening. Gas from the compressed gas source will continue to flow directly into the inflated device until its pressure balances that in the inflated device.

DESCRIPTION OF THE DRAWING

FIG. 1 is an isometric view of the present invention;

FIG. 2 is a longitudinal sectional view of the aspirating inflating apparatus of the present invention in its initial inflating position;

FIG. 3 is a view similar to FIG. 2, but with the apparatus at the completion of its inflating cycle, and

FIG. 4 is a graph illustrating operation of the present invention.

DESCRIPTION OF THE PREFERRED EMBODIMENT

In FIG. 1 there is shown as a source of compressed gas a tank or bottle 10 which through a valve 11 delivers the compressed gas at a substantially constant pressure and through a pressure line 12 feeds compressed gas to an aspirating inflating apparatus 14 which in turn inflates a device 16, such as a life raft, escape slide, bag, or other device. The apparatus 14 comprises an aspirating tube 18 mounted to a housing 20 by means of a tube positioning cylinder and piston assembly 22 and a back pressure diaphragm 24.

The aspirating or inlet tube 18 comprises a rear inlet 26, a middle combined fluid section 28 and a forward outlet end 30 which diverges moderately outwardly. The rear inlet edge of the tube 18 is curved outwardly and back on itself to form a circumferential lip 32 which, as will be disclosed hereinafter, provides for a smooth inflow of air and also for proper closure of the apparatus 14.

The aforementioned housing 20 has a forward annular section 34, a middle section 36 and a rear base section 38. The forward annular section 34 serves to connect the apparatus 14 to the inflatable device 16 and also to connect the housing 20 to the aforementioned back pressure diaphragm 24. Thus the annular section 34 is made up of two rings 40 and 42 joined by bolts 44 so as to hold between the rings 40 and 42 an edge perimeter portion 46 of the device 16 defining an opening 48 in the inflatable device 16. The rear ring 42 has a

rearwardly extending annular flange 50 which fits around and is detachably connected to a forwardly extending annular flange 52 of the housing middle section 36. The detachable connection is accomplished by forming in the flanges 50 and 52 matching circumferential grooves, semicircular in section, as to collectively form a circumferential circular passageway 54. A retaining wire 56 is inserted into this passageway 54 through an opening 58 in the outer flange 50. A ring 60 is provided on the wire 56 for easy removal thereof.

The aforementioned housing middle section 36 has the configuration of a cylindrical sidewall of moderate lengthwise dimension, and is formed with a plurality of through openings 62 spaced circumferentially around the entire housing section 36. The housing base 38 is made up of forward and rear plates 64 and 66, respectively, which close the rear end of the housing 20. These two plates 64 and 66 are joined at their perimeters by bolt 68 and the middle portion of the forward plate 64 protrudes moderately forward, as at 70, in frusto-conical fashion so that the two plates 64 and 66 collectively define a rear plenum chamber 72.

Mounted to and extending forwardly from the plate 64 are a plurality of aspirating or pumping nozzles 74. These nozzles 74 are arranged in three concentric circular arrays, with the innermost nozzles extending further forward than the outermost nozzles for greater pumping efficiency. A compressed gas inlet opening 76 for the plenum chamber 72 is formed at the center of the rear plate 66. The air inlet openings 62 are spaced laterally outwardly of the nozzles 74. At the forward facing perimeter portion of the forward plate 64 there is circular rubber gasket 78 which is so positioned and dimensioned that it is able to engage the rear inlet lip 32 of the aspirating tube 18 when the tube 18 is in its furthest rearward position.

The aforementioned positioning and locating assembly 22 for the aspirating tube 18 is mounted to and extends forwardly from the center portion of the forward plate 64 of the housing base 38. This assembly 22 comprises a forwardly extending cylinder 80 of relatively small diameter, in which is housed for reciprocating motion a piston 82. Mounted within the cylinder 80 is a compression spring 84 which bears against a plug 86 in the forward end of the cylinder 80 and against the head 88 of the piston 82. This spring 84 thus urges the piston 82 rearwardly in the cylinder 80. A piston rod 90 extends forwardly from the piston 82 through the cylinder plug 86 to threadedly engage at its forward end an interiorly threaded sleeve-nut 92. The sleeve 92 is in turn joined by struts 94 to the forward end 30 of the aspirating tube 18. The rear end of the cylinder 80 opens at 96 to the plenum chamber 72. Thus as pressurized gas is fed through the inlet 76 into the plenum chamber 72, not only is aspirating or primary gas fed through the nozzles 74, but the cylinder 80 becomes pressurized to force the piston 82 to its furthest forward position against the action of the compression spring 84.

The rear portion of the aspirating tube 18 is positioned within and concentrically aligned with the forward annular section 34 of the housing 20. The diameter of the aspirating tube 18 within the section 36 is moderately smaller than the diameter of the section 36 so that the tube 18 and section 36 define an annular

space 98 therebetween. This space 98 is closed by the aforementioned back pressure diaphragm 24.

This diaphragm 24 in its "rest" or "non-stressed" condition has a generally frusto-conical configuration and is made of a moderately flexible material, such as rubber. It has an inner circumferential sleeve 100 which is integral with the diaphragm and grips the outer surface of the aspirating tube 18. Made integral with and extending radially outward from the sleeve 100 is the diaphragm itself 24, which terminates at its outer end in a forwardly extending lip 102. This lip is firmly held between an inner retaining ring 104 and the aforementioned flange 52 of the housing 20. A locking ring 106 holds the gripping ring 104 in place.

To describe the operation of the present invention let it be assumed that the inflatable device 16 is in a collapsed position, the tank 10 is charged with compressed gas with the valve 11 closed. In this condition there will be no pressure in the plenum chamber 72 and the urging of the compression spring 84 against the piston 82 will cause the piston 82, as seen in FIG. 3, to hold the aspirating tube 18 to its rearward position.

When it is desired to inflate the device 16, the valve 11 is opened, and pressure flows through the line 12 into the plenum chamber 72 to pressurize the rear end of the cylinder 80 and also eject high pressure gas through the aspirating nozzles 74. The pressure against the piston 82 overcomes the force of the compression spring 84 to move the piston 82 along with the aspirating tube 18 to its furthest forward position, as shown in FIG. 2. In this position, the rear inlet lip 32 of the tube 18 is spaced just forward of the housing middle section 36, so that the openings 62 are fully open. The aspirating action of the high pressure gas blowing in jet fashion from the nozzles 74 into the aspirating tube 18 causes aspirated air to be drawn radially inwardly through the openings 62 through the passageway 108 between the tube lip 32 and the housing base section 38, and into the tube 18. In the midsection of the tube 18 the aspirated and aspirating gases mix and exit through the front opening 30 to inflate the device 16.

As the pressure in the inflatable device 16 builds up, the back pressure against the diaphragm 24 increases. This, in conjunction with the force of the spring 84 causes the piston 82 with the tube 18 to move rearwardly. This causes a reduction in the effective area of the aspirating passageway 108. By properly selecting the force of the spring 84, the size of the pressure face of the piston 82, the aspirating characteristics of the nozzle 74, and the transverse cross-sectional area of the diaphragm 24, the aspirating tube 18 can be caused to move rearwardly at a rate to properly regulate the inflow of aspirated air to obtain proper inflating action from the aspirating gas jets from the nozzle 74 and the aspirated air drawn in through the openings 62. That is to say, the aspirating tube 18 moves rearwardly to close the effective area of the aspirated air passageway 108 so as to increase the effective inflating pressure of the gas moving out the nozzles 74 and thus overcome the back pressure in the device 16. At the end of the inflating cycle the pressure from pressurized container 10 begins to decline to reduce pressure in the cylinder 80. Finally, the back pressure against the diaphragm 24 and the action of the spring 84 acts to overcome the now reduced pressure in the cylinder 80 so that the

tube 18 moves to its furthest rearward position as shown in FIG. 3. In this position, the tube is located within the aspirated air inlet portion 36 of the housing 18, and the inlet lip 34 bears against the rubber gasket 78 in the housing base section 38, thus closing off the aspirated air passageway 108 and effectively closing the bag opening 48. Gas will continue to flow from the tank 10 out the nozzles 74 until the pressure in the line 12 and the inflated device 16 becomes equalized.

It will be noted that in the closed position of FIG. 3 any outside force (such as an impact from wave action if the apparatus is used in a life raft) would be directed through the air opening 62 laterally against the aspirating tube 18. This would cause some lateral motion between the inlet lip 32 and the sealing gasket 78, but would not cause axial motion to cause these two members to separate, since the force of the compression spring 84 is sufficient to overcome any moderate thrust loads directed along the longitudinal axis of the tube 18.

EXAMPLES

To demonstrate the operation of the present invention, the apparatus was constructed as shown in FIGS. 1 through 3. The inside diameter of the tube 18 was about 4.5 inches. The effective inside diameter of forward annular housing section 34 was about 6.0 inches. Thus, the effective pressure area of the diaphragm 24 (the cross-sectional area of the annular passageway 11 between the tube 18 and the housing section 34, the width of this passageway being about three-fourths inch) was about 12.5 square inches. The diameter of the cylinder 80 was five-eighths inch. The container 10 was a gas bottle having a volume of 900 cubic inches, pressurized with air to 3,000 psi. The inflatable 16 had an inflated volume of 396 cubic feet. The pressure regulating valve 11 delivered pressurized gas at a constant pressure of about 175 psi. The spring 84 exerted a force of 24.9 pounds with the tube 18 in its furthest rearward position, and the force of the spring would increase at a rate of 13.3 pounds per inch of forward travel of the tube 18. The path of travel of the tube 18 from its furthest forward position to its furthest rearward position was 1.2 inches.

With this arrangement, the bag 16 was inflated by this apparatus in about 6 seconds. The operating characteristics of the apparatus are illustrated by the graph of FIG. 4. At zero seconds the valve 11 was opened. Immediately the pressure in the chamber 72 began to rise to pressurize the cylinder 80 and exhaust air through the nozzles 74. At about 0.2 seconds when the pressure in the cylinder 80 reached about 80 pounds psi, it began to overcome the force of the spring 84, and at about 0.35 seconds, the tube 18 was fully extended to its full forward position. At about 3.0 seconds, the back pressure in the bag 16 began to rise. At about 4.1 seconds, the back pressure in the bag 16 had risen to about 1 psi to exert on the diaphragm 24 an effective back pressure force of about 12.5 pounds. This, along with the force of the compressed spring (about 40 pounds) was sufficient to start the tube 18 moving rearwardly. At 5.0 seconds, the bag pressure had risen to about 1.65 psi, and the tube had moved back 40 percent of its length of travel. At about 5.2 seconds supply pressure began to drop. At 5.7 seconds

the tube closed entirely and the inflating gas from the nozzles continued to discharge into the bag (without any aspirating air) to bring the bag up to full pressure of 2 psi. Thus, it can be seen that during the final stage of inflation when a back pressure is developing in the bag, the aspirating passageway 108 diminishes as the back pressure increases to provide the proper inflow of aspirating air.

The above inflating cycle was repeated 20 times with substantially the same results.

What is claimed is:

1. In combination with:

- a. a device to be pressurized by a pressurizing fluid and having a fluid inlet opening,
- b. means to supply a pressurizing fluid,

c. an apparatus arranged to receive said pressurizing fluid from said supply means and to pressurize said device, said apparatus comprising:

1. a mounting structure comprising a base member,
2. an aspirating tube having a downstream end communicating with said device through said opening, and an upstream end, the upstream end of the tube having an inlet portion located forward of said base member, said aspirating tube being movable between a forward position where the tube inlet portion and the base member define an aspirated fluid passageway therebetween, and a rearward position where said tube inlet portion bears against the base member so as to close the aspirated fluid passageway,
3. aspirating nozzle means mounted to said base member and adapted to receive pressurizing fluid from said supply means and direct said pressurizing fluid in aspirated flow into said aspirating tube,
4. aspirating tube locating means responsive to pressurizing fluid from said supply means to move said aspirating tube to its forward position,

the improvement comprising means to move said tube between its open and closed positions and also to regulate the location of the aspirating tube between its forward and rear positions, in a manner to reduce the area of the aspirated fluid passageway in response to back pressure in the device to be pressurized, the improvement comprising:

- a. a housing portion connected to said device to be pressurized and defining said inlet opening of said device,
- b. said aspirating tube being mounted proximate to said opening and being spaced laterally inwardly of said housing portion, and
- c. a back pressure regulating member connected between said aspirating tube and said housing portion so as to close an area therebetween and having a back pressure surface responsive to pressurizing fluid within said device in a manner that when fluid pressure increases in said device said regulating member moves the aspirating tube toward said base member so as to reduce the area of the aspirated fluid passageway.

2. The apparatus as recited in claim 1, wherein said back pressure regulating member comprises an annular member connected to the aspirating tube and extending radially outwardly therefrom.

3. The apparatus as recited in claim 2, wherein said annular member is a diaphragm connected at a fixed location on both said housing and said aspirating tube.

4. The apparatus as recited in claim 3, wherein said diaphragm is made of a flexible material and has a normal frusto-conical configuration, wherein the diaphragm tapers forwardly with the tube in its forward position and tapers rearwardly with the tube in its rearward position.

5. The apparatus as recited in claim 1, wherein there are spring biasing means arranged to push said tube to a closed position, said spring means being arranged that with said tube in its forward position, said spring means acts with maximum force to move said tube toward its rearward position.

6. The apparatus as recited in claim 5, wherein the tube locating means comprises a piston and cylinder assembly mounted to said base and extending forwardly into the aspirating tube, said spring means being mounted to said assembly to urge said piston to a rearward position.

7. The apparatus as recited in claim 6, wherein said base member has a plenum chamber leading directly to both said nozzle means and said cylinder and piston assembly so that when pressurized fluid is delivered to said nozzle means, the pressurizing fluid is also acting on said piston and cylinder assembly to urge said tube to its forward position.

8. The apparatus as recited in claim 5, wherein said back pressure regulating member comprises an annular member connected to the aspirating tube and extending radially outwardly therefrom.

9. The apparatus as recited in claim 8, wherein said annular member is a diaphragm connected at a fixed location on both said housing and said aspirating tube.

10. The apparatus as recited in claim 9, wherein said diaphragm is made of a flexible material and has a normal frusto-conical configuration, wherein the diaphragm tapers forwardly with the tube in its forward position and tapers rearwardly with the tube in its rearward position.

11. The apparatus as recited in claim 1, wherein there is:

- a. a locating piston and cylinder assembly mounted to said base and extending forwardly into the aspirating tube and connected to said aspirating tube,
- b. a spring mounted to said piston and cylinder assembly and arranged to urge said assembly to a closed position,
- c. said back pressure means comprising a flexible annular diaphragm connected between said housing portion and said aspirating tube.

12. An inflating apparatus adapted to receive high pressure fluid and direct said fluid in aspirating fashion to inflate a device, said apparatus comprising:

- a. a mounting structure comprising a base portion and a housing portion which is adapted to be connected to the device to be inflated and which defines an opening by means of which said device is to be inflated,
- b. an aspirating tube mounted proximate to said opening and being spaced laterally inward from said housing portion, said aspirating tube having a downstream end adapted to communicate with said device through said housing opening, an up-

stream end, the upstream end of the tube having an inlet portion located forwardly of the base member, said aspirating tube being movable between a forward position where the tube inlet portion is spaced forwardly of said base member so that the tube inlet portion and the base member define an aspirated fluid passageway therebetween, and a rearward position where said tube inlet portion bears against the base member so as to close the aspirated fluid passageway,

- c. aspirating nozzle means mounted to said base portion and adapted to receive high pressure fluid and direct said fluid in aspirated flow into the aspirating tube,
- d. aspirating tube locating means responsive to high pressure fluid to move said aspirating tube to its forward position, and
- e. a back pressure regulating member connected between said aspirating tube and said housing portion so as to close an area therebetween and having a back pressure surface adapted to be responsive to pressurizing fluid within the device to be inflated in a manner that when fluid pressure increases in the device said regulating member moves the aspirating tube toward said base member so as to reduce the area of the aspirated fluid passageway.

13. The apparatus as recited in claim 12, wherein said back pressure regulating member comprises an annular member connected to the aspirating tube and extending radially outwardly therefrom.

14. The apparatus as recited in claim 13, wherein said annular member is a diaphragm connected at a fixed location on both said housing and said aspirating tube.

15. The apparatus as recited in claim 14, wherein said diaphragm is made of a flexible material and has a normal frusto-conical configuration, wherein the diaphragm tapers forwardly with the tube in its forward position and tapers rearwardly with the tube in its rearward position.

16. The apparatus as recited in claim 12, wherein there are spring biasing means arranged to push said tube to a closed position, said spring means being arranged that with said tube in its forward position, said spring means acts with maximum force to move said tube toward its rearward position.

17. The apparatus as recited in claim 16, wherein the tube locating means comprises a piston and cylinder assembly mounted to said base and extending forwardly into the aspirating tube, said spring means being mounted to said assembly to urge said piston to a rearward position.

18. The apparatus as recited in claim 17, wherein said base member has a plenum chamber leading directly to both said nozzle means and said cylinder and piston assembly so that when pressurized fluid is delivered to said nozzle means, the pressurizing fluid is also acting on said piston and cylinder assembly to urge said tube to its forward position.

19. The apparatus as recited in claim 16, wherein said back pressure regulating member comprises an annular member connected to the aspirating tube and extending radially outwardly therefrom.

9

20. The apparatus as recited in claim 19, wherein said annular member is a diaphragm connected at a fixed location on both said housing and said aspirating tube.

21. The apparatus as recited in claim 20, wherein said diaphragm is made of a flexible material and has a normal frusto-conical configuration, wherein the diaphragm tapers forwardly with the tube in its forward position and tapers rearwardly with the tube in its rearward position.

22. The apparatus as recited in claim 12, wherein there is:

10

- a. a locating piston and cylinder assembly mounted to said base and extending forwardly into the aspirating tube and connected to said aspirating tube,
- b. a spring mounted to said piston and cylinder assembly and arranged to urge said assembly to a closed position,
- c. said back pressure means comprising a flexible annular diaphragm connected between said housing portion and said aspirating tube.

* * * * *

15

20

25

30

35

40

45

50

55

60

65