

[54] CONTAINER SAFETY DISPENSING CLOSURE

[76] Inventor: Peter Strefford, 85 South Dr., Toronto, Ontario, Canada

[22] Filed: Aug. 6, 1973

[21] Appl. No.: 385,851

[52] U.S. Cl. .... 222/153

[51] Int. Cl. .... B67d 5/32

[58] Field of Search.. 222/153, 182, 402.11-402.14, 222/553, 540, 565; 239/540

[56] References Cited

UNITED STATES PATENTS

1,124,742	1/1915	Hustus .....	239/540
2,573,624	10/1951	Svendsen .....	222/402.11 X
2,924,393	2/1960	Robert .....	222/553 X
2,971,681	2/1961	Galbierz.....	222/565 X
3,401,843	9/1968	Ahrens et al. ....	222/182
3,724,724	4/1973	Gach.....	222/153
3,747,807	7/1973	Gach.....	222/182 X
3,788,523	1/1974	Thomas .....	222/153

Primary Examiner—Allen N. Knowles

Assistant Examiner—Norman L. Stack, Jr.

Attorney, Agent, or Firm—George H. Riches and Associates

[57] ABSTRACT

This invention relates to a child proof safety dispensing closure for containers of drugs and other dangerous products. The closure has an outer cap with a dispensing aperture therethrough which is permanently fixed to the container before or after the products are inserted into the container. An inner cap is positioned

within the outer cap above the rim of the container. The inner cap is rotatable relative to the outer cap, and in a preferred embodiment has a dispensing aperture which may be aligned with the dispensing aperture in the outer cap. A separate opening tool having a manually rotatable vertically extending shaft with an eccentrically located cylindrical boss on its lower end is wall mounted in a location inaccessible to children. In the assembled position, a torsional spring continuously biases the inner cap toward a closed position in which the two dispensing apertures are not in alignment. In order to rotate the inner cap to the open position, the container is manually raised beneath the opening tool to a position wherein the shaft is inserted through a circular hole in the top of the outer cap and the eccentric boss is snugly received in a smaller circular seat eccentrically located in the inner cap beneath the circular hole. Manual rotation of the opening tool by a handle causes the inner cap to rotate relative to the outer cap to the open position in which the two dispensing apertures are in alignment thereby providing a passageway for the contents of the container. A depressible pushbutton member with a flat inner surface which is positioned in a seat opening in the outer cap opposite the dispensing aperture is manually depressed while the inner cap is in this open position to have its flat inner surface engage a flat vertical outer segment on the inner cap. This maintains the inner cap in the open position, allowing the container to be removed from the opening tool and the contents to be dispensed therefrom by tilting the container in a conventional manner. Upon release of the pushbutton member, the inner cap automatically returns to the closed position under the influence of the torsional spring to seal in the contents of the container.

10 Claims, 15 Drawing Figures

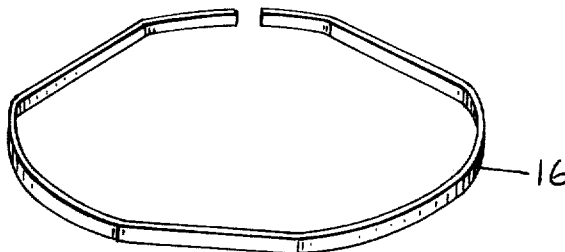

SHEET 1

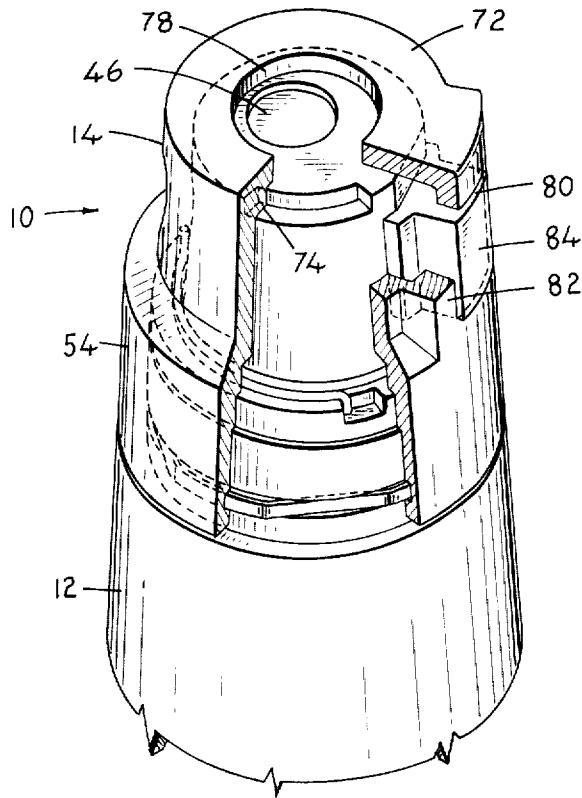

FIG. 1.

FIG. 3.

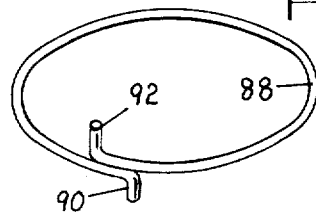

FIG. 2.

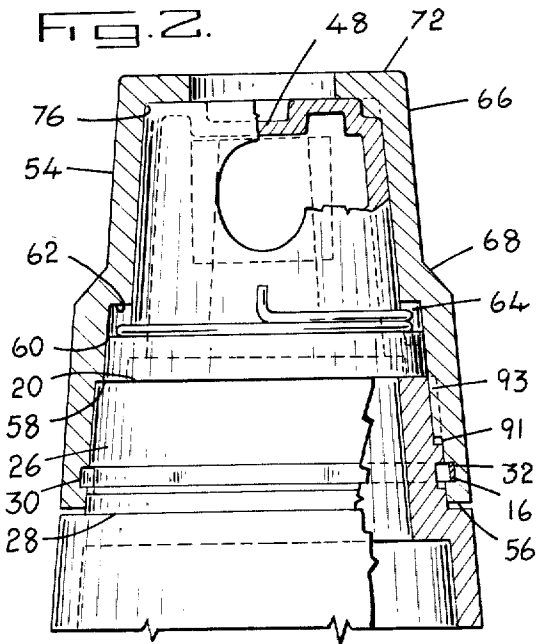

FIG. 4.

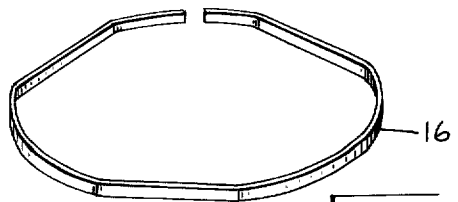
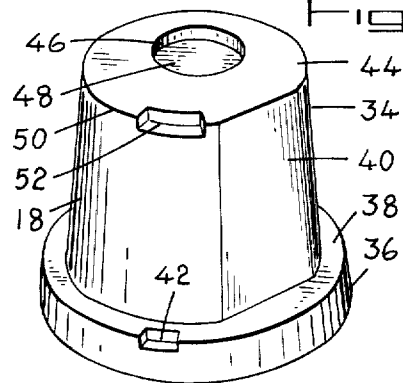

FIG. 5.

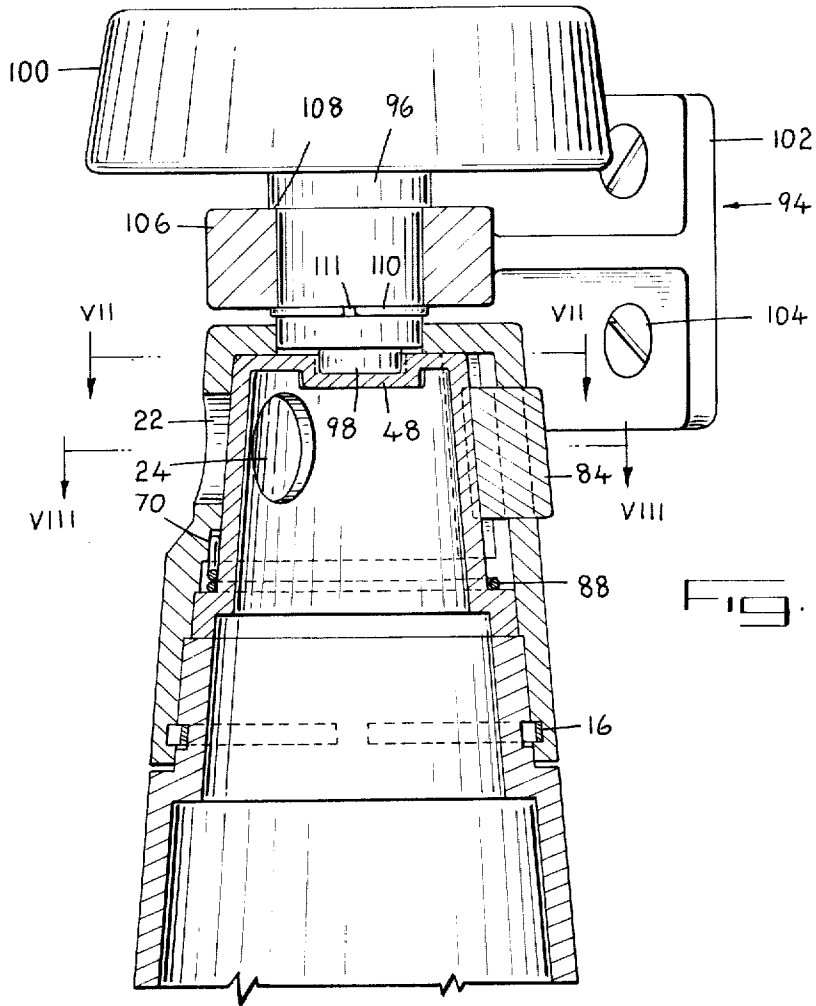

FIG. 6.

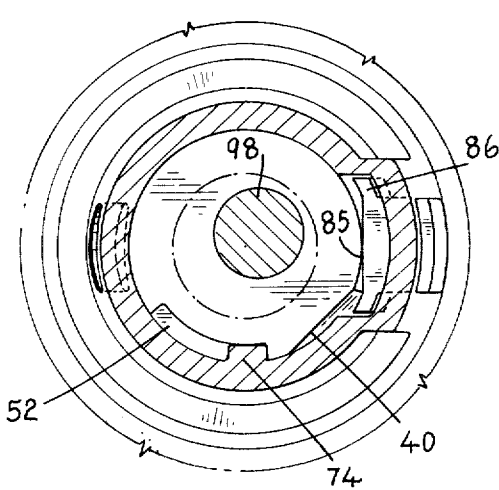

FIG. 7.

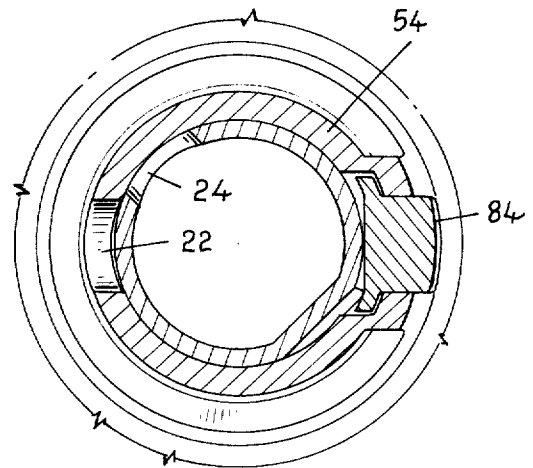

FIG. 8.

FIG. 9.

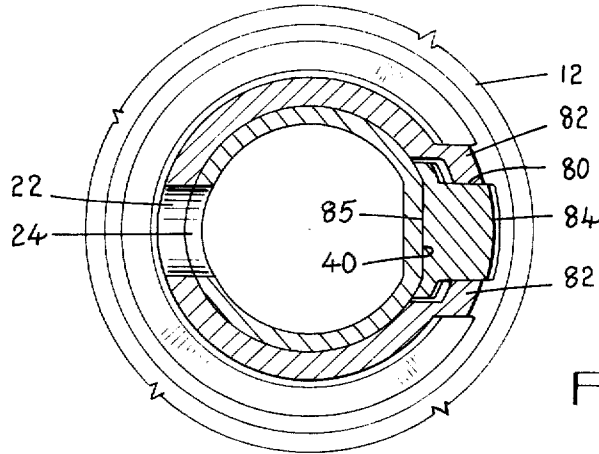
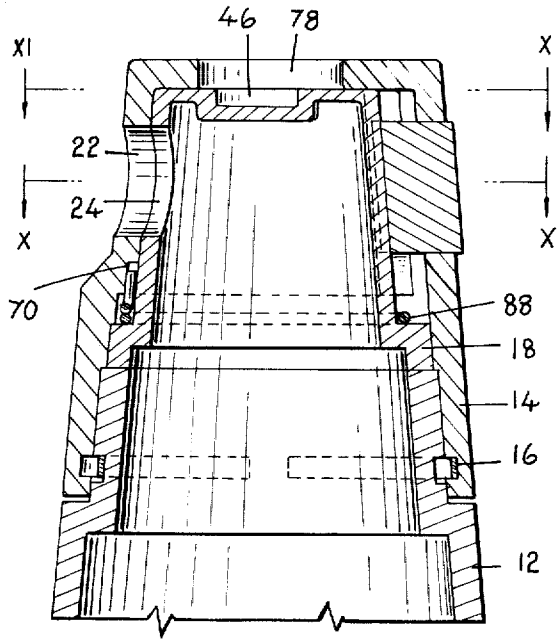

FIG. 10.

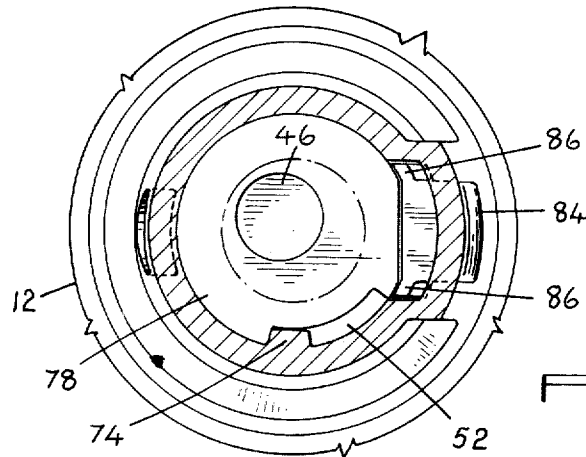

FIG. 11.

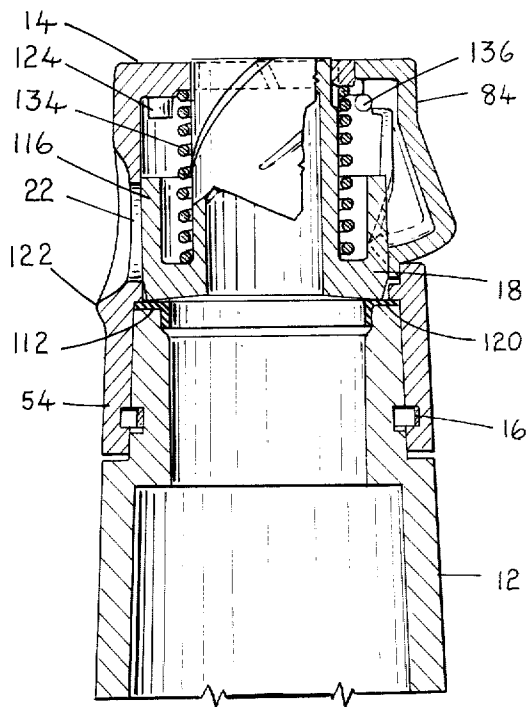

FIG. 12.

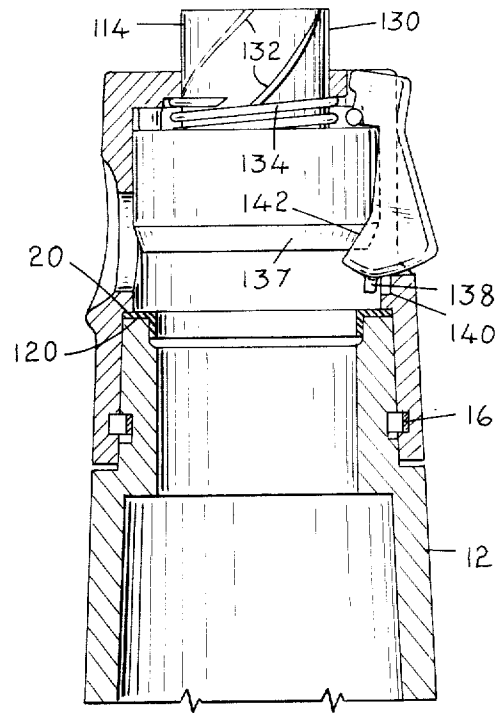

FIG. 13.

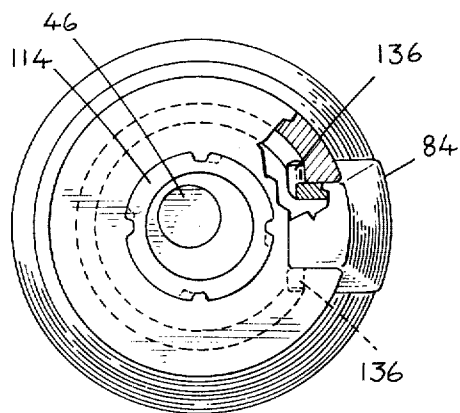

FIG. 14.

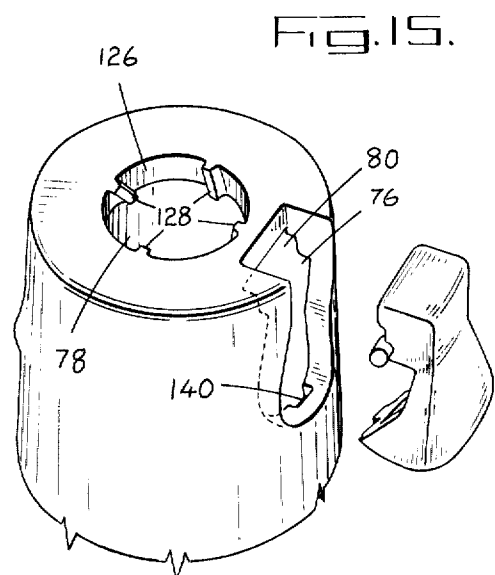

FIG. 15.

## CONTAINER SAFETY DISPENSING CLOSURE

This invention relates generally to safety dispensing closures for containers such as bottles and the like, and more particularly to such a safety closure which may be permanently attached to the container, and which may be opened by using a separate opening tool and manually retained in the opened position for dispensing of the contents of the container without the use of the opening tool.

The continual increase in the use of drugs and other dangerous poisonous household products, which in many cases are confusing in odour and appearance with normally edible products, has created a need for effective child proof closures for the containers of these products. In the past, a large variety of different types of safety closures have been developed, but unfortunately none of these has proven to be entirely satisfactory so as to come into widespread use. These prior safety closures have generally been of the type which require more strength and/or mechanical ability than that possessed by a child to remove the closure. Another type of previous developed safety closure are those which emit an audible signal upon removal of the closure from the container.

More recently, safety closures have been developed which require the use of an external tool to remove the closure from the container. While being a substantial improvement, this type of closure still has the disadvantage that it is possible for a child to obtain possession of an inadvertently misplaced tool and remove the closure. In addition, in many cases it is possible to remove the closure using devices other than the designed removal tool. Furthermore, each of the above types of safety closures has the serious disadvantage that the closure is removable and occasionally it is inadvertently left off or improperly replaced on the container following use.

Accordingly, it is an object of the present invention to at least partially overcome these disadvantages by providing a container safety dispensing closure which is easily permanently attached to the container, which may be opened without removal by using an external opening tool, which may be manually retained in the open position during dispensing of the contents of the container, and which will automatically return to the closed position following use.

To this end, in one of its aspects, the invention provides a container safety dispensing closure comprising a hollow outer cap adapted to be securely fixed to the container, an inner cap rotatably located within the outer cap, the inner cap being adapted to be rotated from a first closed position wherein the contents of the container are securely retained therein to a second open position wherein the contents of the container may be dispensed therefrom by separate manually operated engaging means adapted to engage the inner cap, biasing means adapted to bias the inner cap towards the closed position, and holding means adapted to permit the inner cap to be manually releasably retained in the open position following disengagement of the engaging means, the biasing means returning the inner cap to the closed position upon release of the holding means.

In another of its aspects, the invention further provides a safety dispensing closure wherein the biasing means comprises a spring located on the inner cylindrical

portion of the inner cap and extending in compression from a trough defined between the inner cylindrical portion and the outer lip portion to the top of the outer cap.

Further objects and advantages of the invention will appear from the following description taken together with the accompanying drawings in which:

FIG. 1 is a partially cut-away perspective view of a safety closure according to a preferred embodiment of the invention;

FIG. 2 is a partial sectional view of the embodiment of the invention seen in FIG. 1;

FIG. 3 shows the torsional spring of the embodiment of the invention seen in FIG. 1;

FIG. 4 is a perspective view of the inner cap of the embodiment of the invention seen in FIG. 1;

FIG. 5 shows the retaining ring of the embodiment of the invention seen in FIG. 1;

FIG. 6 is a partial sectional view of the preferred embodiment of the invention seen in FIG. 1 with the safety closure engaged by the opening tool in the closed position;

FIG. 7 is a cross sectional view taken along line VII—VII in FIG. 6;

FIG. 8 is a cross sectional view taken along line VIII—VIII in FIG. 6.

FIG. 9 is a view similar to FIG. 6 without the opening tool, with the safety closure in the open position;

FIG. 10 is a cross sectional view taken along line X—X in FIG. 9;

FIG. 11 is a cross sectional view taken along line XI—XI in FIG. 9;

FIG. 12 is a sectional view of a dispensing closure according to a second embodiment of the invention, showing the safety closure in the closed position;

FIG. 13 is a view similar to FIG. 12 showing the safety closure in the open position;

FIG. 14 is a partially cut-away plan view of the embodiment of the invention seen in FIG. 12; and

FIG. 15 is a perspective view of the outer cap of the embodiment of the invention seen in FIG. 12, with the pushbutton member displaced from the outer cap.

Reference is first made to FIG. 1 which shows a safety dispensing closure 10 permanently connected to a container 12 (only partially shown). The safety closure 10 has an outer cap 14 which is secured to the container 12 by retaining ring 16, and an inner cap 18 (seen in FIG. 4) rotatably received within the outer cap adjacent the rim 20 of the container 12. The outer cap 14 has a first circular dispensing aperture 22 and the inner cap 18 has a second circular dispensing aperture 24. The inner cap 18 is rotatable within the outer cap 14 from the closed position shown in FIG. 6 in which the first and second dispensing apertures 22, 24 are not in alignment, to the open position shown in FIG. 9 in which the first and second dispensing apertures 22, 24 are in alignment to provide a passageway for dispensing the contents of the container by tilting the container in a conventional manner.

In more detail, the container 12, which of course may be of any desired size or shape, has a generally cylindrical collar 26 extending upwardly from horizontal shoulder 28. While the container 12 and the outer and inner caps 14, 18 are shown as being slightly tapered in the preferred embodiment in order to facilitate manufacture and assembly, they may equally as well be cylindrical in shape and are conveniently hereinafter referred

to as being generally cylindrical. Collar 26 has an outwardly opening circumferential slot 30 which matches with an inwardly opening slot 32 in the outer cap to cooperatively receive resilient split retaining ring 16. As clearly seen in FIG. 4, the hollow inner cap 18 has a generally cylindrical upper body portion 34 joined to a slightly larger diameter generally cylindrical base portion 36 at horizontal shoulder 38. The upper body portion 34 has a flat vertical outer segment 40 and the shoulder 38 has a small upwardly opening notch 42 located in a predetermined position around its circumference. The innercap 18 has a flat upper surface 44 with a shallow circular seat eccentrically located therein. The seat 46 has a floor 48 which seals the seat against possible leakage of the contents of the container there-through. The upper edge 50 of the upper body portion 34 of the inner cap 18 has a circumferential upwardly and outwardly opening notch 52 extending in a predetermined position around its circumference. In the embodiment shown, the second dispensing aperture 24 is circular in shape and extends through the upper body portion 34 of the inner cap 18 in a position diametrically opposite to the flat vertical outer segment 40.

The outer cap 14 is similarly hollow and generally cylindrically shaped. As mentioned above, the wall 54 of the outer cap 14 has a narrow inwardly opening circular slot 32 extending horizontally around it adjacent its lower edge 56 which is located adjacent the horizontal shoulder 28 of the container 12. Working upward, the wall 54 of the outer cap 14 has a first circumferential shoulder 58 which abuts on the top rim 20 of the container 12 in the assembled position. A second horizontal circumferential shoulder 60 projects slightly inwardly to abut on the outwardly extending shoulder 38 of the inner cap 18. Third circumferential shoulder 62 extends inwardly above the second circumferential shoulder 60 to define a circumferential space 64 extending between the shoulder 38 of the inner cap 18 and the third circumferential shoulder 62 of the outer cap 14. The outer surface 66 of the wall 54 of the outer cap 14 forms an inwardly sloping circumferential shoulder 68 adjacent the third circumferential shoulder 62. The third circumferential shoulder 62 has a small downwardly opening notch 70 located in a predetermined position around its circumference. The outer cap 14 is formed of a size and shape to cooperatively receive the inner cap 18 with sufficient tolerance to permit the inner cap freedom to rotate within the outer cap with the base portion 36 of the inner cap 18 abutting on the top rim 20 of the container 12. The outer cap 14 has a flat top 72 with a downwardly projecting lug 74 located in a predetermined radial position in the corner 76 formed where the flat top 72 meets the wall 54. The flat top 72 has a centrally located circular hole 78 extending therethrough which is larger in diameter than the circular seat 46 in the inner cap 18 and provides access from above to the circular seat 46. As mentioned above, the wall 54 of the outer cap 14 has a first dispensing aperture 22 extending therethrough which is of a size and shape and at a height to align with the second dispensing aperture 24 in the open position, as seen in FIG. 9. The wall 54 of the outer cap 14 also has a rectangular seat opening 80 extending therethrough diametrically opposite the first dispensing aperture 22. The seat opening 80 is defined between a pair of vertical extending flanges 82 formed by the wall 54 to receive pushbutton member 84. The pushbutton

member 84 is adapted to move radially in the seat opening 80, and has a pair of vertical side wings 86 which engage the vertical extending flanges 82 to limit its radial outward movement. The pushbutton member 84 has a flat inner surface 85 extending between the wings 86 which mates with the flat segment 40 on the inner cap 18. The circular torsional spring 88, seen in FIG. 3, extends around the inner cap 18 in circumferential space 64, in the assembled position. The torsional spring 88 has a downwardly extending end portion 90 which engages notch 42 in the shoulder 38 of the inner cap 18, and upwardly extending end portion 92 which engages downwardly opening notch 70 in the third circumferential shoulder 62 of the outer cap 14.

The outer cap 14, inner cap 18 and pushbutton member 84 are preferably formed of a plastic material such as an acrylic, a cellulose or a similar thermoplastic material having sufficient strength and rigidity to avoid distortion during use. These members may be conveniently and economically constructed by a conventional injection molding process, although it will be understood that the components of the closure according to the invention may be formed of any suitable materials by any suitable means.

While the contents may be inserted into the container after the safety closure is fixed to the container, normally the safety closure is assembled and securely fixed to the container following insertion of the desired contents into the container as follows. The pushbutton member 84 is inserted into the seat opening 80 in the outer cap 14 from within the outer cap. The torsional spring 88 is then located in position around the inner cap 18 on shoulder 38 with the downwardly extending end portion 90 received in notch 42. The outer cap 14 is then placed over the inner cap 18 and lowered to a position where the upwardly extending end portion 92 of torsional spring 88 is engaged in the notch 70. The outer cap 14 is then rotated slightly clockwise relative to the inner cap 18 to place the torsional spring 88 in tension. The outer cap 14 is then further lowered to a position in which lug 74 is received in notch 52. It is apparent that to provide for this assembly sequence, end portion 92 of torsional spring 88 must be longer than the height of lug 74. The split retaining ring 16 is then positioned in slot 32 in the wall 54 of the outer cap 14.

The collar 26 of the container 12 is provided with a vertically opening keyway 91 and the way 54 of the outer cap 14 has a matching key portion 93. The inner and outer caps are then forced downward over the collar 26 with the key portion 93 in receipt in the keyway 91, until the resilient retaining ring 16 snaps into slot 30 in the collar in the assembled position. While the retaining ring 16 and key portion 93 satisfactorily secure the outer cap to the container in a non-rotatable position, it is apparent that a variety of alternate structures may be used to provide the same result. For instance, the outer cap may be heat sealed to the container or the outer cap and the container may be formed as a single unit with the inner cap being installed through a bottom opening. The radial locations of notches 42, 52 and 70, lug 74 and the dimensions of coil spring 88 provide that in the initially assembled position, the dispensing closure is pretensioned in the closed position with the first and second dispensing apertures 22, 24 out of alignment, as seen in FIG. 6.

FIG. 6 shows a separate wall mounted opening tool 94 having an elongated cylindrical shaft 96 with a

smaller diameter cylindrical boss 98 eccentrically located on one end thereof and a manually rotatable circular handle 100 on the other end. The opening tool 94 has a bracket member 102 which may be fixed in a desired location to a wall or other structure in a conventional manner by screws 104, with collar 106 projecting from the wall in a horizontal position. The collar 106 rotatably receives the shaft 96 in a vertically extending position between flange 108 and split ring 110 received in circular groove 111. As may be seen, in this position, manual rotation of handle 100 in the sleeve 106 rotates boss 98 which is eccentrically located on shaft 96.

In use, the bracket member 102 is mounted in a convenient position in a household out of the reach of children. When it is desired to dispense the contents from the container, the container is lifted upwardly under the bracket member 102 and the container or the handle 100 is rotated until the end of shaft 96 is received in circular hole 78 in the outer cap 14 and eccentric boss 98 is received in circular seat 46 in inner cap 18, as seen in FIG. 6. Then, while manually retaining the container 12 from rotating and maintaining a slight upward pressure on the container with one hand to retain this engagement with the bracket member 102, the handle 100 is manually rotated counterclockwise with the other hand. As the shaft 96 is engaged by the central circular hole 78 in the outer cap 14, movement of the eccentric boss 98 which is received in the mating circular seat 46 causes the inner cap 18 to correspondingly rotate counterclockwise with the handle 100 from the closed position (seen in FIGS. 6 to 8) to the open position (seen in FIGS. 9 to 11). As described above, the predetermined relationship of the torsional spring 88 and notches 42 and 70 as well as the relationship of circumferential notch 52 and tooth 74 determines that in the initially assembly position the dispensing closure is in the closed position. As seen in FIG. 6, in the closed position the second dispensing aperture 24 through the inner cap 18 is covered by the wall 54 of the outer cap 14, thereby providing no possible passage for dispensing or spillage of the contents from the container. The torsional spring 88 which engages both the inner cap 18 and outer cap 14, as described above, exerts a continuous bias on the inner cap towards the closed position. As the inner cap 18 is rotated counterclockwise against this bias, a "stop" is provided at the open position by lug 74 reaching the end of circumferential notch 52. In the open position, the first and second dispensing apertures 22, 24 are in alignment (as seen in FIG. 9), thereby providing a passageway through which to dispense the contents of the container. While retaining the handle 100 in this position against the bias of torsional spring 88, pushbutton member 84 is depressed radially inwardly until flat inner surface 85 bears on flat vertical outer segment 40 of the inner cap 18. While maintaining this radially inward pressure on the push-button member 84 with the thumb or forefinger of the hand holding the container 12, the handle 100 of the opening tool 94 is released and the container lowered from engagement with the opening tool 94. As may be seen in FIG. 10, this bearing contact between the flat inner surface 85 of the pushbutton member 84 and the flat vertical outer segment 40 of the inner cap 18 is sufficient to maintain the inner cap 18 in the open position against the bias of torsional spring 88. The container is then tilted to dispense the contents in a conventional manner. After the desired quantity of the contents have

been dispensed the pushbutton member 84 is released and the inner cap 18 returns to the closed position under the influence of torsional spring 88. Thereby, the safety dispensing closure according to the invention provides the advantage that it is very difficult to rotate the inner cap 18 to the open position with objects other than the opening tool, which is not accessible to children. Furthermore, the inner cap 18 automatically returns to the closed position following use, thereby avoiding any possibility of inadvertently leaving the closure in the open position.

In the second embodiment of the invention disclosed in FIGS. 12 to 15, many of the features are identical to those of the preferred embodiment described above, and therefore features common to both embodiments are described and shown using the same reference numerals. In this embodiment, operation of the dispensing closure is similar to that described above except that counterclockwise rotation of the inner cap 18 relative to the outer cap 14 lifts the inner cap 18 to uncover first dispensing aperture 22 through the wall 54 of the outer cap 14 in the open position.

In this second embodiment, the top rim 20 of the collar 26 of the container 12 has a sealing ring 112 with a uniform L-shaped cross section secured to it. The hollow inner cap 18 is formed of an inner cylindrical portion 114 and an outer vertically extending lip portion 116 connected together at their bases to define an upwardly opening cylindrical U-shaped trough 118 therebetween. The base of the inner cap 18 is slightly concave to provide a pointed outer edge 120 which seats on the sealing ring 112 in the closed position to provide a seal particularly suitable when the contents of the container are a liquid. The generally cylindrical outer cap 14 has a slot 32 in its wall 54 to receive a retaining ring 16 in cooperation with a slot 30 in the collar 26 of the container in an arrangement as described above in regard to the preferred embodiment. The wall 54 of the outer cap 14 has a circular dispensing aperture 22 extending therethrough. In this case, a protruding lip 122 is shown beneath the dispensing aperture to facilitate the pouring of liquids from the container. The flat top 72 has a vertical stop 124 projecting downwardly therefrom a predetermined distance radially adjacent the dispensing aperture 22. The top 72 has a circular hole 78 extending centrally therethrough, defined by an inner cylindrical surface 126 which is interrupted by a plurality of spaced inwardly projecting helically extending teeth 128. The inner cylindrical portion 114 of the inner cap 18 is adapted to extend through the circular hole 78 in the outer cap 14, and its outer cylindrical surface 130 is interrupted by a corresponding plurality of helically extending slots 132 which are adapted to threadably receive the teeth 128. The teeth 128 and slots 132 cooperate to provide that the inner cap 18 is raised to the open position (shown in FIG. 13) as the inner cap 18 is rotated counterclockwise. A compression spring 134 is located about the inner cylindrical portion 114 of the inner cap 18 and extends between the U-shaped trough 118 to the underside of the flat top 72 to exert a constant bias on the inner cap towards the closed position seen in FIG. 12. Seat opening 80 is located in the wall 54 of the outer cap 14 diametrically opposite the dispensing aperture 22, and extends upwardly into the flat top 72 as seen in FIG. 15. Pushbutton member 84 which is adapted to be received for pivotal motion in the seat opening 80 has a pair of retain-

ing pins 136 extending from its respective sides. In the assembled position, the pins 136 are received in corner 76 where the flat top 72 meets the wall 54 of the outer cap 14. The pushbutton member 84 has a finger 138 extending downwardly from its bottom which is received in indentation 140 in the wall 54 of the outer cap 14 to limit outward pivotal motion of the pushbutton member 84 about the horizontal axis 137. The pushbutton member 84 has a lower inwardly sloping surface 142 adjacent its bottom.

The separate opening tool (not shown) is identical to that described above in regard to the preferred embodiment. The inner cylindrical portion 114 of the inner cap 18 is hollow and adapted to receive the end of the elongated cylindrical shaft 96. The inner cap 18 has a circular seat 46 with a floor 48 eccentrically positioned in the inner cylindrical portion 114. This seat 46 is adapted to receive the eccentric boss 98 when the end of elongated cylindrical shaft 96 is received in the inner cylindrical portion 114 of the inner cap 18.

In use, the operation of this second embodiment of the invention is very similar to that described above of the preferred embodiment of the invention. The container is manually lifted beneath the wall hung opening tool 94 and the shaft is rotated into a position in which the boss 98 is received in the eccentric circular seat 46. While maintaining a slight upward pressure on the container, the handle 100 of the opening tool 94 is rotated counterclockwise, thereby similarly rotating the inner cap 18 counterclockwise. The threadable engagement of the helically extending slots 132 by the teeth 128 causes the inner cap 18 to lift relative to the outer cap 14 against the bias of the compression spring 134. As may be seen, this raises the lip portion 116 of the inner cap 18 from the closed position shown in FIG. 12 in which it covers the dispensing aperture 22 in the outer cap 14, to the open position shown in FIG. 13 in which it abuts on vertical stop 124 and does not block the dispensing aperture 22. While holding the container and the handle 100 of the opening tool 94 in the open position, the pushbutton member 84 is depressed to pivot it inwardly to the position shown in FIG. 13 in which the sloping surface 142 of the pushbutton member 84 engages a matching sloping face 137 on the inner cap 18 to securely retain it in this raised open position. The pushbutton member 84 is maintained in this depressed position while the container 12 is disengaged from the opening tool 94 and tilted to dispense the contents through the dispensing aperture 22. The pushbutton member 84 is then released and the compression spring 134 then automatically lowers the inner cap 18 to the closed position in which the pointed outer edge 120 is seated on the sealing ring 112. This embodiment of the invention is particularly suitable for use with liquids as the compression spring 134 exerts a constant downward bias on the inner cap 18 against the sealing ring 112 to provide a fluid tight seal. In addition, as mentioned above, the dispensing aperture 22 is provided with a protruding pouring lip 122.

Although the disclosure describes and illustrates preferred embodiments of a safety dispensing closure according to the invention, it is to be understood that there are numerous other embodiments of the invention and the invention is not restricted to these particular embodiments.

What I claim is:

1. A container safety dispensing closure comprising:

- a. a hollow outer cap having a generally cylindrically shaped outer wall and a flat top, the wall having an inwardly opening circumferential slot on a lower portion thereof, the outer cap adapted to be securely fixed to the container by a retaining ring cooperatively received by said slot and a matching outwardly opening circumferential slot on the container, the wall having a first dispensing aperture extending therethrough substantially diametrically opposite a seat opening, the flat top having a circular central hole extending therethrough;
  - b. a hollow generally cylindrically shaped inner cap rotatably received within the outer cap in sliding contact with an upper rim of the container, the inner cap having a second dispensing aperture adapted to be aligned with the first dispensing aperture in the outer cap, the inner cap having a circular seat located beneath the circular hole in the top of the outer cap, the circular seat being smaller in diameter and in eccentric alignment with the circular hole, the inner and outer caps adapted to be engaged by a separate wall mounted opening tool having a manually rotatably cylindrical shaft with a smaller diameter cylindrical boss eccentrically located on one end thereof, the said circular seat adapted to receive the said end of the shaft and the circular seat adapted to receive the eccentric boss in an engaged position wherein manual rotation of the shaft correspondingly rotates the inner cap within the outer cap whereby the inner cap may be rotated from a closed position wherein the second dispensing aperture is covered by the wall of the outer cap to an open position wherein the first and second dispensing apertures are in alignment, thereby providing a passage for dispensing of the contents of the container by tilting the container, the inner cap having a flat vertical outer segment radially opposite the second dispensing aperture;
  - c. a torsional spring located between the inner and outer caps with one end engaging the inner cap and the other end engaging the other cap whereby the inner cap is subjected to a continuous rotational bias towards the closed position;
  - d. a pushbutton member horizontally reciprocatingly received in the seat opening in the outer cap, the pushbutton member having a flat inner surface adapted to be brought into bearing contact with the flat outer segment of the inner cap by depressing the pushbutton member to manually retain the inner cap in the open position following disengagement of the opening tool, the torsional spring immediately returning the inner cap to the closed position upon release of the pushbutton member.
2. A container safety dispensing closure comprising:
- a. a hollow outer cap adapted to be securely fixed to the container, the outer cap having a first dispensing aperture therein;
  - b. an inner cap rotatably located within the outer cap and having a sealing portion, the inner cap being adapted to be rotated from a first closed position wherein the sealing portion seals the first dispensing aperture in the outer cap to a second open position wherein the first dispensing aperture is unsealed to permit the contents of the container to be dispensed therefrom, the inner cap being rotated by a separate opening tool having a rotatable shaft adapted to mateably engage the inner cap;

- c. biasing means adapted to bias the inner cap towards the closed position; and
- d. holding means adapted to permit the inner cap to be manually releasably retained in the open position following disengagement of the engaging means, the biasing means returning the inner cap to the closed position upon release of the holding means.

3. A safety dispensing closure as claimed in claim 2 wherein the inner cap has a second dispensing aperture therein, the first and second dispensing apertures being in alignment in the open position and out of alignment in the closed position.

4. A safety dispensing closure as claimed in claim 2 wherein the rotatable shaft of the separate opening tool is cylindrical with a smaller diameter cylindrical boss eccentrically located on one end thereof and a manually rotatable handle on the other end, the outer cap having a top with a circular hole extending therethrough adapted to matingly receive the said one end of the opening tool shaft in an engaged position, the inner cap having a circular seat therein in eccentric alignment with the first opening in the outer cap, the seat adapted to matingly receive the said cylindrical boss in an engaged position wherein the inner cap may be rotated from the closed to the open position by rotation of the opening tool handle while holding the container and outer cap fixed.

5. A safety dispensing closure as claimed in claim 2 wherein the rotatable shaft of the separate opening tool is cylindrical with a smaller diameter cylindrical boss eccentrically located on one end thereof and a manually rotatable handle on the other end, the opening tool also having a bracket member adapted to rotatably secure the said shaft in a desired vertical position on a wall, the outer cap having a top with a circular hole extending therethrough adapted to matingly receive the said one end of the opening tool shaft in an engaged position, the inner cap having a circular seat therein in eccentric alignment with the first opening in the outer cap, the seat adapted to matingly receive the said cylindrical boss in an engaged position wherein the inner cap may be rotated from the closed to the open position by rotation of the opening tool handle while holding the container and outer cap fixed.

6. A safety dispensing closure as claimed in claim 2

wherein the inner cap has a closure lip portion which covers the first aperture in the closed position, the inner and outer caps being interconnected whereby the closure lip portion is moved to a position not covering the first aperture when the inner cap is rotated to the open position.

7. A safety dispensing closure as claimed in claim 6 wherein the rotatable shaft of the separate opening tool is cylindrical with a smaller diameter cylindrical boss eccentrically located on one end thereof and a manually rotatable handle on the other end thereof, the outer cap having a top with a circular hole extending therethrough, the inner cap having an inner cylindrical portion extending above the outer lip portion, the inner cylindrical portion adapted to extend through the opening in the outer cap and to matingly receive the said one end of the opening tool shaft in an engaged position, the inner cylindrical portion having a circular seat eccentrically located therein, the seat adapted to matingly receive the said cylindrical boss in the engaged position wherein the inner cap may be rotated from the closed to the open position by rotation of the opening tool handle while holding the container and outer cap fixed.

8. A safety dispensing closure as claimed in claim 7 wherein the inner cylindrical portion of the inner cap has a plurality of outward opening helical slots therein and the top of the outer cap has a corresponding plurality of teeth extending into the hole, the teeth adapted to threadably engage the slots whereby the inner cap is lifted by rotation from the closed to the open position wherein the closure lip portion does not cover the first dispensing aperture in the outer cap.

9. A safety dispensing closure as claimed in claim 7 wherein the biasing means comprises a spring located on the inner cylindrical portion of the inner cap and extending in compression from a trough defined between the inner cylindrical portion and the outer lip portion to the top of the outer cap.

10. A safety dispensing closure as claimed in claim 7 wherein the container has an upper rim with a circular sealing ring secured thereto against which the inner cap is brought into bearing contact in the closed position to provide the container with a liquid tight seal.

\* \* \* \* \*

50  
55  
60  
65