

No. 679,876.

Patented Aug. 6, 1901.

J. E. BLAKE.
MOTOR.

(Application filed Mar. 26, 1901.)

(No Model.)

3 Sheets—Sheet 1.

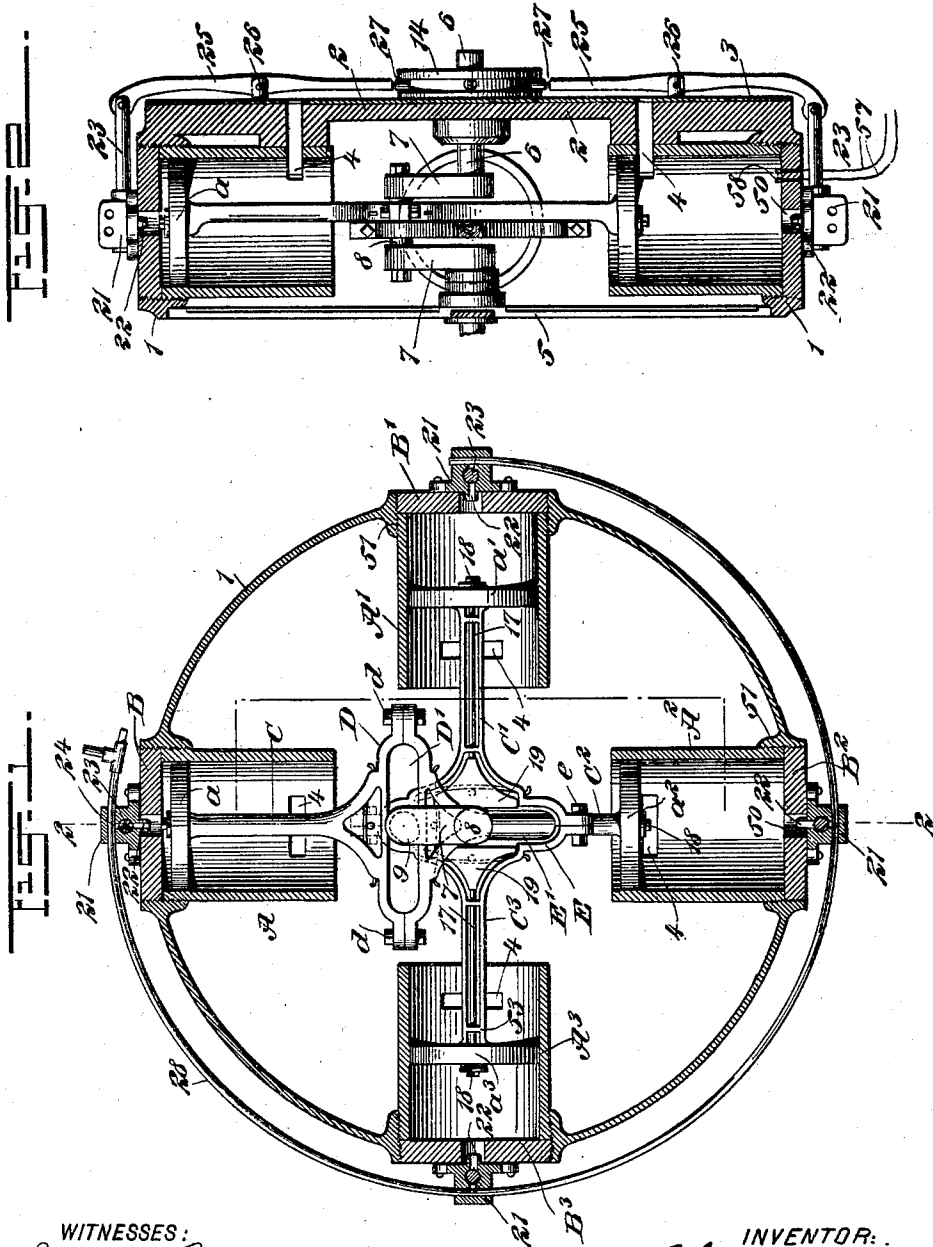

WITNESSES:
Julius Hirt
Rita Bradt

INVENTOR:
John E. Blake
BY *Fred Wacker*
ATTORNEY

No. 679,876.

Patented Aug. 6, 1901.

J. E. BLAKE.
MOTOR.

(Application filed Mar. 26, 1901.)

(No Model.)

3 Sheets—Sheet 2.

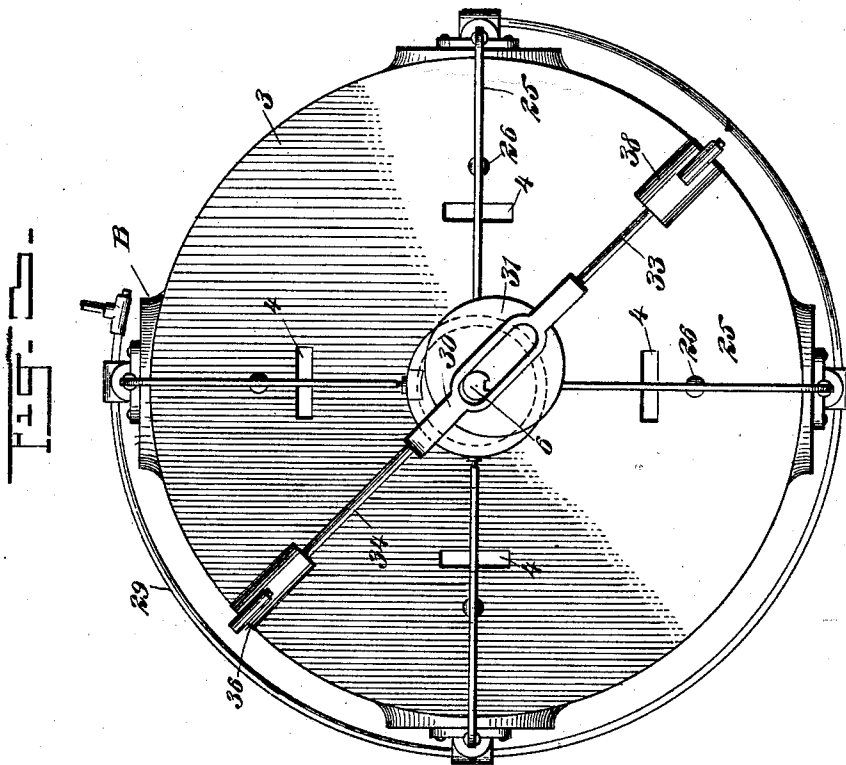
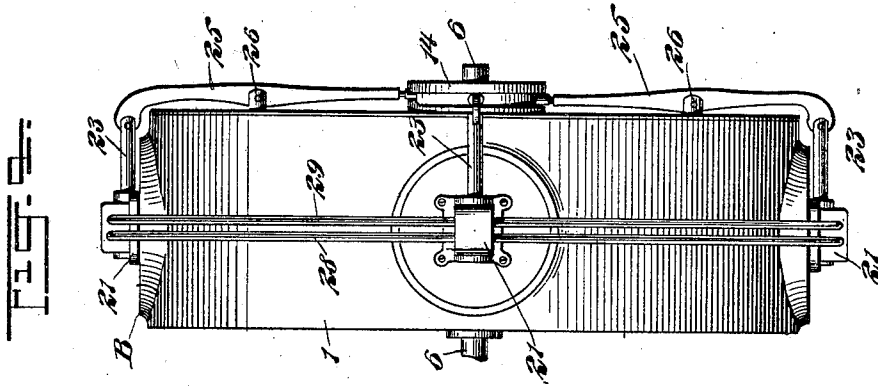

WITNESSES:

Julius Kutz
Rita Pracht

INVENTOR

John E. Blake
BY
Fred W. Wacker
ATTORNEY

J. E. BLAKE.
MOTOR.

(Application filed Mar. 26, 1901.)

(No Model.)

3 Sheets—Sheet 3.

FIG. 5.

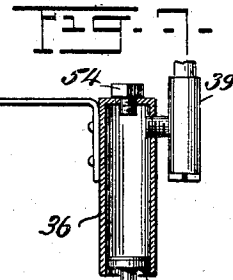
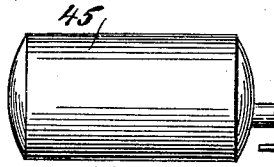
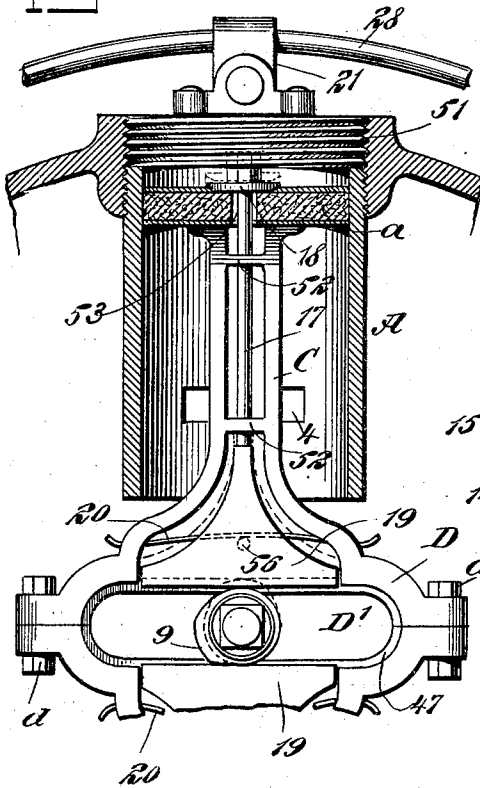

FIG. 8.

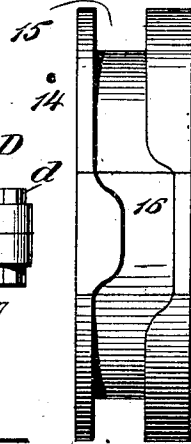

FIG. 9.

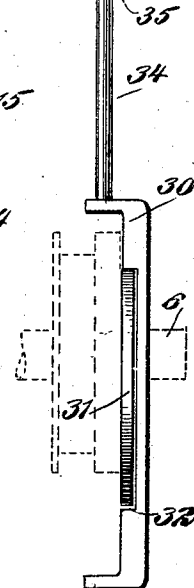
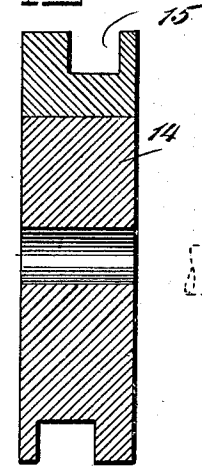
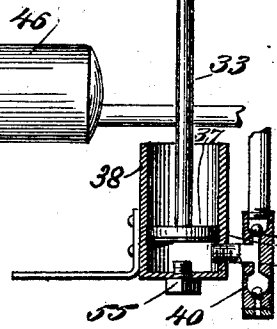
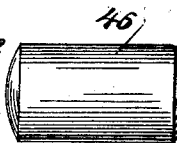
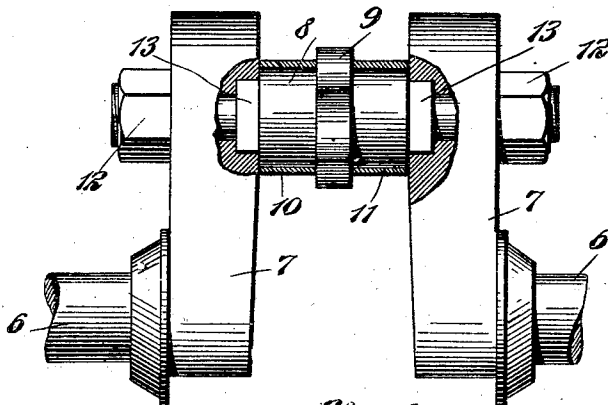
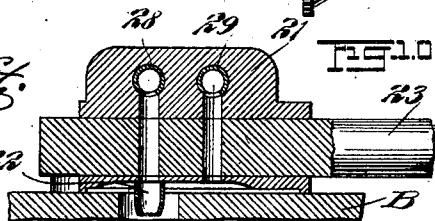

FIG. 10.



WITNESSES:
Julius [Signature]
Rita [Signature]



INVENTOR:
John E. Blake
 BY *Fred [Signature]*
 ATTORNEY

UNITED STATES PATENT OFFICE.

JOHN E. BLAKE, OF NEW YORK, N. Y.

MOTOR.

SPECIFICATION forming part of Letters Patent No. 679,876, dated August 6, 1901.

Application filed March 26, 1901. Serial No. 52,909. (No model.)

To all whom it may concern:

Be it known that I, JOHN E. BLAKE, a citizen of the United States of America, and a resident of New York city, borough of Manhattan, county and State of New York, have invented certain new and useful Improvements in Motors, of which the following is a specification.

This invention relates to an improvement in motors adapted for use with steam, air, gas, or any other liquid or fluid pressure or power, whether applied expansively, explosively, or otherwise and whether the motor is intended for use in the propulsion of vehicles or transportation facilities or for driving machinery or for other purposes in the arts and sciences, the object of the invention being to provide a more efficient, economical, and satisfactory motor than has heretofore been possible with known constructions and combinations of mechanism.

The invention consists, essentially, in a multiple arrangement of cylinders containing pistons connected together by a novel arrangement of valve-carrying yokes, through which the power generated by the movement of the piston is applied by means of mechanical connections to a single common driving-shaft, the whole being arranged in a compact form within a suitably-shaped casing, which carries the supply devices for furnishing the requisite fluid or other pressure to the cylinders; and the invention furthermore consists in manifold details in the construction, arrangement, and combination of the various mechanical parts, substantially as will be hereinafter more fully described and then pointed out specifically in the ensuing clauses of the claim.

In the annexed drawings, illustrating my invention, Figure 1 is a vertical sectional view of my improved motor. Fig. 2 is a transverse sectional elevation on the line 2 2 of Fig. 1. Fig. 3 is a rear face elevation. Fig. 4 is an outside edge view or elevation. Fig. 5 is a sectional detail view of one of the cylinders, its piston, piston-yoke, release-valve, and other parts, all represented on an enlarged scale. Fig. 6 is an enlarged detail view, in partial section, of the crank-shaft, its cranks, crank-pin, &c. Fig. 7 is an edge view of the two air-pumps employed in connection

with my improved motor, one for compressing air into the gasoline-reservoir and the other for compressing air into the air-reservoir, the cylinders of said pumps being shown in section. Fig. 8 is an edge view of the cam which operates the valve-opening levers for controlling the supply of air and liquid or fluid pressure to the cylinders. Fig. 9 is a sectional view of the same. Fig. 10 is an enlarged sectional view of a supply-valve and its casing.

Similar characters of reference designate corresponding parts throughout all the different figures of the drawings.

My improved motor has a frame that consists, essentially, of a circular or cylindrical band or ring 1, and for the sake of lightness this, as well as the other parts of the motor—such of them as will admit of it—may be of aluminium, although I reserve the liberty of making them of such metal as may be found most advantageous.

I wish to suggest that a very high efficiency may be attained with my improved motor, even though the ring 1 is not more than a foot or two in diameter and only a few inches in width and the other parts of the motor correspondingly proportioned, for the compact and novel combination allows of the development of exceedingly large power in small space.

One of the open sides of the frame 1 is covered by a skeleton frame 5, having a bearing at its center to support one end of the drive-shaft 6. The other side of frame 1 has a skeleton casting 2, which likewise provides a central bearing for the other end of the drive-shaft 6 and also furnishes substantial stiffness and strength to the ring 1 by reason of the solidity and thickness of its construction, as is indicated in Fig. 2, where it is seen to be made integral with the ring 1 at the periphery of the latter. At certain points in the ring or band 1—say four or more—which points are at equal distances from each other, are formed circular openings 51. These are internally screw-threaded. The ring 1 is made thicker at these points in order to reinforce and strengthen the edges of the openings, and into the said openings from the interior of the ring 1 are screwed a series of open-ended cylinders, while from the out-

side or exterior of the ring 1 screw-threaded plates or heads are screwed into the same openings tightly up against the abutting ends of the cylinders, said screw-threaded heads carrying the supply-valve devices. The cylinders therefore lie diametrically opposite to each other and on the radii of the ring 1. These cylinders in the present example of the invention are designated A, A', A², and A³. The screw-threaded valve-carrying heads of these cylinders are denoted, respectively, B, B', B², and B³. The inner ends of the cylinders are open to the atmosphere, not having any heads. Within the cylinders A, A', A², and A³ are respectively the pistons *a*, *a'*, *a*², and *a*³. Cylinders A and A² are opposite to each other and cylinders A' and A³ are opposite to each other. The pistons *a*, *a'*, *a*², *a*³ are respectively provided with piston-rods C, C', C², C³, the inner ends of these rods spreading out into a yoke form and those adjacent to each other being secured together. Thus the piston-rods C and C², belonging to pistons *a* and *a*², have their inner yoked ends secured together by bolts *d*, *d*, thus forming a central yoke D, having therein a slot D', the direction of which is at right angles to the axes of the cylinders A and A², and also the rods C' and C³, belonging to the pistons *a'* and *a*³, have their inner yoked ends secured together by means of bolts *e*, *e*, thereby forming an inner yoke E, which has a slot E', the direction of which is at right angles to the axes of the cylinders A' and A³. The yokes D and E are closely adjacent to each other, and the slots D' and E' likewise overlap each other, so that their planes of travel are closely contiguous.

The drive-shaft 6 has the crank-arms 7, 7, through which passes the crank-pin 8, having thereon square shoulders 13, 13, that enter correspondingly-shaped recesses in the cranks 7, 7, there being nuts 12, 12 on the projecting screw-threaded ends of the pin 8, so that in this way said pin is rigidly and non-rotatively secured to the cranks 7, 7. At the center of the pin 8 is a cam 9, integral therewith or rigidly cast thereon. At each side of cam 9, between it and the adjacent crank 7, is a friction sleeve or ring 10 on the one side and 11 on the other side. The friction-sleeve 10 is located in the slot E' of yoke E and the friction-sleeve 11 in the slot D' of yoke D, while the cam 9 lies partly within the slot D' and partly within the slot E'. It will be observed that the edges of the slots D' and E' are rabbeted, as shown at 47 in Fig. 5, and the cam operates along the rabbeted edge. The function of the cam is to control the opening of certain valves belonging to the pistons, and it performs its function in a way which I shall presently describe. Obviously as the two yokes reciprocate and travel across each other's paths the cam 9 will vibrate from end to end of slot D' and also from end to end of slot E', traveling in the slots all the time and doing

its duty in connection with the valves referred to.

Each of the pistons *a*, *a'*, *a*², and *a*³ is perforated at the center with an opening 53, that functions as a port to provide an escape or release for the pressure in advance of the face of the piston while the latter is on its return stroke. On the side of the piston nearest the cylinder-head is a valve 18, adapted at times to close the port 53. Valve 18 is provided with a valve-rod 17, which is supported in guides 52, 52 on the piston-rod, and the inner end of the valve-rod 17—that is, the end nearest the center of the mechanism—is provided with an integral or fixedly-attached plate 19, arranged and adapted to slide in a recess in the side of the yoke D or E, as the case may be, said plate 19 having an edge which is at right angles to the direction of the valve-rod 17, and which edge is adjacent to the slot D' or E', as the case may be, and on which edge the cam 9 operates through the rotation of the crank-shaft for the purpose of moving the slide 19, and consequently opening the valve 18. A spring 20 is tensioned between shoulders on the yoke that carries slide 19 and a pin 56 on said slide for the purpose of normally forcing the slide 19 toward the cam or into the position in which the valve 18 will be closed upon its seat and the passages 53 covered. Accordingly it will be understood that each piston has a centrally-located valve the function of which is to permit the escape of pressure from the advancing side of the piston on the return stroke, that these valves are controlled by the action of a single cam which works against the edges of the four slides 19 belonging to the four valves, two of which slides are contiguous to the slot D' of yoke D and the other two to the slot E' of yoke E, two of which are at right angles to the other two—that is to say, two are horizontal and the other two are perpendicular—if the motor happens to be in a position where certain of the cylinders are vertical, and that the cam in the rotation of the crank-shaft moves from one straight-edged slide 19 to each of the others in a constant and unending succession so long as the motor is in operation. The point of the cam 19—that is to say, the salient part of the cam—is preferably placed at an acute angle to the vertical line of the cranks 7, as it has been found in actual practice that the best results are attainable with the cam-point so situated.

It has already been stated that the inner ends of the cylinders are open. It must likewise be particularly noted that each cylinder at a short distance from its inner end is provided with a large lateral exhaust-port 4, which is passed by the piston in moving to the inner end of its stroke, so as to allow the exhaust of the impelling pressure to take place at the end of the working stroke.

On the driving-shaft 6, outside of the frame

2 and the thin circular cover 3, which is indicated in Fig. 2 and which is conveniently employed for the purpose of covering one side of the frame, is a cam-wheel 14, consisting of a circular disk in the periphery of which is cut a path 15, which lies in a plane at right angles to the axis of wheel 14, excepting at one point 16, where the path deflects and forms an offset or irregularity in the path which is sufficient to furnish a laterally-acting cam effect upon the ends of a series of levers 25, as many in number as there are cylinders, said levers being for the purpose of actuating the supply-valves for the cylinders. These levers 25 are pivoted on short studs 26, and the ends that are engaged by the cam-path 15 16 are furnished with small antifriction-rollers 27. Obviously as the wheel 14 rotates whenever the offset part 16 of the cam-groove receives the end of one of the levers it will vibrate said lever and in consequence shift the valve attached to the outermost end of the lever. To the outer end of each of these levers is pivoted a valve-rod 23, which enters a valve-casing 21. At the center of each of the cylinder-heads B, B', B², and B³ is an orifice or perforation 50, into which projects the vaporizer-nozzle 22, formed integral with and projecting from the valve-casing 21, there being one of these casings bolted or otherwise firmly secured to each of the cylinder-heads which I have just mentioned.

Passing around the ring or band 1 and embracing it quite closely are two or more tubes or pipes 28 and 29. One, as 28, is an oil-supply pipe and the other, as 29, is an air-supply pipe. These pipes pass through the several valve-casings 21, within which they are furnished with orifices to allow the outlet into the interior of said casings 21 of the respective contents of the pipes, and these contents are conveyed through the vaporizer-nozzles 22 into the cylinders, the flow of the vaporized oil and the air being controlled by the valves 23, already alluded to. The oil-pipe 28 leads from the gasolene-reservoir 45, and the air-pipe 29 leads from the compressed-air tank 46.

On the drive-shaft 6, alongside of the cam-wheel 14, is an eccentric 31. This engages the shoulders 32 on an angular plate 30, which embraces the eccentric 31, as shown in Fig. 7, and which is slotted, as shown in Fig. 3, to permit the passage through it of the shaft 6. The angular plate 30 carries at one end a rod 34, attached to a piston 35, working in a cylinder 36, and at the other end it carries a rod 33, attached to a piston 37, working in a cylinder 38, both cylinders 36 and 38 being open-ended at one end. The cylinder 38 is preferably of greater diameter and shorter length than the cylinder 36. These two cylinders and their pistons constitute two pumps, the smaller, as 36, being a pump to supply air to the gasolene-reservoir, so that oil in the latter may be forced under pressure through the pipe 28 to the supply-valve and the vaporizing devices. The cylinder 38 and its piston

have the function of acting as a pump to compress air into the air-reservoir, whence it is removed for use in making the explosive mixture by means of the conveying-tube 29. On the wall of cylinder 36 is an elbow or coupling 39, and on the wall of the cylinder 38 is a similar elbow or coupling 40. One end of the coupling 39 admits air from the atmosphere, and at the point of entry there is a ball check-valve, while the other end of coupling 39 is connected to a pipe running to the gasolene-reservoir, and at this point of connection there is another ball check-valve. These two ball-valves allow of such an operation of the pump that the piston 35 may by suction draw in air from the atmosphere on one stroke and at the next stroke may force it out of the cylinder 36 and compress it into the gasolene-reservoir. The coupling 40 is similarly provided with a couple of check-valves, and air is similarly compressed by the piston 37 and driven from the cylinder 38 into the air-reservoir 46.

In referring to the way in which an explosive mixture is introduced into the cylinders it is assumed, of course, that the motor is to be employed as an explosive-motor; but it will be understood that this is only one use of it and that it may equally well be used with steam, air, or other fluid pressure without any material alteration in its construction and the arrangement of the various parts. When used as an explosive-motor, it will be necessary to equip each of the cylinders with some suitable igniting devices, an example of which is indicated at 58' in the drawings; but as no claim is made thereto herein it is unnecessary to explain the construction of the igniting in detail. When the motor is used with steam, air, or other fluid pressure, immaterial modifications and readjustments will obviously be desirable; but these will not necessitate going outside of the legitimate scope of the claims hereto appended.

From the foregoing description of the construction of the various parts the operation of the motor will be evident. As has been seen, the pistons move in pairs, and in the case of the use of the invention as a gas-motor the explosions will take place upon each piston in succession. After the explosive mixture has been introduced into the end of a cylinder and compressed therein and the spark applied the ensuing explosion will drive the piston to the opposite end of its stroke, and when it passes the exhaust-port 4 the spent products of the explosion will escape through said port to the atmosphere, or will very nearly escape; only a small amount being left remaining in the cylinder. When the piston begins its return stroke and passes the port 4, the valve-operating cam will begin to open the release or back-pressure valve 18, and this will be kept open during about two-thirds of the return movement of the piston, thereby allowing the contents of the cylinder on the advancing side of the piston,

which contents consist almost wholly of the undisposed - of spent products, to escape through the central port 53, the open end of the cylinder, to the atmosphere. When the cam is released from the valve-slide 19, the valve 18 will close under the action of the spring 20, and almost simultaneously with this closing the new charge of explosive mixture which is being introduced will be compressed by the onward movement of the piston to the extreme limit of its compression, stroke, and instantaneously the spark will be applied, the explosion will ensue, and the piston will again be driven on its working stroke. This operation will take place with each of the four pistons in succession, and the power generated by the movement of each piston will be applied to the common crank-shaft, from which it may be imparted to such driven machine as it may be connected with.

It will be preëminently manifest that my present motor is well adapted because of its compactness and efficiency for use in actuating automobile carriages. I mention this simply as one of a variety of uses to which it may be put. It may be operated with great satisfaction in the propulsion of light machinery, and it may be connected for use with a multitude of different kinds of mechanisms to be driven.

Many changes in the exact construction and combination may be made without departing from the invention, as I have described, and I reserve the liberty of varying from the precise embodiment herein set forth so far as the claims will admit. The motor is well adapted for use in marine service for the propulsion of boats.

Having thus described my invention, what I claim as new, and desire to secure by Letters Patent, is—

1. In a motor, the combination with a central revolving crank-shaft, of a series of radially-disposed relatively stationary cylinders, valve-provided pistons therein, piston-rods for connecting the pistons in pairs, said rods traveling across the face of each other, a cam on the crank of the shaft, and release-valves carried by the pistons and operated by the cam.

2. In a motor, the combination with a central revolving crank-shaft, of a series of radially-disposed relatively stationary cylinders, valve-provided pistons therein, piston-rods that connect the pistons in pairs, said rods being provided with elongated slots at right angles to their axes which slots are engaged by the crank-pin on the shaft, a valve-operating cam on the crank-pin, and supply-valves for introducing the impelling pressure into the cylinders.

3. In a motor, the combination with a shaft, of a series of radially-disposed cylinders, pistons therein, piston-rods connecting the pistons into pairs, said rods having elongated slots at right angles to their axes, a crank-

pin carried by the cranks on the shaft and engaging the slots, release-valves carried by the pistons and having valve-rods whose ends are in proximity to the aforesaid slots, and a cam on the crank-pin which operates upon the said valve-rods.

4. In a motor, the combination with a shaft, of a series of radially-disposed cylinders, pistons therein, piston-rods having right-angled slots, a crank-pin supported by the shaft and engaging the slots, valves in the pistons having valve-rods, a cam rigid on the crank-pin and actuating the valve-rods, and valves for supplying an explosive or other impelling mixture to the cylinders.

5. In a motor, the combination of a shaft, the cylinders, pistons therein, piston-rods connecting the pistons in pairs, a crank-pin on the crank of the shaft, which pin engages the piston-rods, valves in the pistons, a cam on the crank-pin for actuating the valves, supply-valve devices for introducing the impelling pressure into the cylinders, a series of levers for operating said valve devices successively, and a cam-wheel on the main shaft that engages and vibrates the aforesaid levers.

6. In a motor, the combination with an open-ended cylinder and a supply-valve device at one end, of a piston within the cylinder, said piston having a port, a valve controlling said port, said valve having a valve-rod, a piston-rod connected to the piston and having a yoke providing a slot at right angles to the piston-rod, a slide belonging to the valve-rod and having its edge parallel to the yoke-slot, a crank-shaft, a cam thereon operating in connection with the slide and a valve-closing spring.

7. In a motor, the combination with a crank-shaft, having a single crank-pin, of a series of cylinders, pistons therein, rods connecting the pistons in pairs, and a cam on the crank-pin engaging said rods.

8. In a motor, the combination with a shaft having a single crank, of a series of cylinders, pistons therein, rods connecting the pistons in pairs, valves carried by the pistons and a single cam on the crank for engaging and actuating the valves.

9. In a motor, the combination with a shaft having a crank, of the cylinders, pistons therein, rods connecting the pistons, valves carried by the pistons, said valves having rods, slides belonging to these rods, springs for closing the valves, and a cam on the crank for opening the valves.

10. In a motor, the combination with a shaft having a crank, of the cylinders, pistons therein, rods connecting the pistons, valves carried by the pistons and having valve-rods, slides belonging to said rods, valve-closing springs, sleeves loose on the crank-shaft and working in slots in the piston-rods, and a cam rigid on the shaft and operating against the valve-slides for opening the valves, together with valve-closing springs.

11. In a motor, the combination with a shaft having a crank, of the cylinders, pistons therein, rods connecting the pistons, valves carried by the pistons, said valves having rods, slides 5 belonging to these rods, springs for closing the valves, a cam on the crank for opening the valves together with supply-valve devices for introducing the impelling pressure into the cylinders, a series of levers for operating said valve devices, and a cam-wheel 10 on the main shaft that engages and vibrates the levers.

12. In a motor, the combination with a shaft having a crank, of the cylinders, pistons therein, rods connecting the pistons, valves carried 15 by the pistons, said valves having rods, slides belonging to these rods, springs for closing the valves, a cam on the crank for opening the valves, supply-valve devices for introducing the impelling pressure into the cylinders, 20 circular pipes arranged around the cylinders for conveying the pressure to the valves, levers for operating the valve devices, said levers being pivoted, and a cam-wheel having 25 an irregular peripheral groove for receiving and vibrating said levers, said cam-wheel being mounted on the main shaft.

13. In a motor, the combination of a shaft, the cylinders, pistons therein, piston-rods 30 connecting the pistons, a crank on the shaft which crank engages the piston-rods, valves in the pistons, a cam on the crank for actuating the valves, supply-valve devices for introducing the impelling pressure into the cylinders, levers for actuating these devices, a 35 cam-wheel on the main shaft for vibrating

the levers, pumping devices for forcing the pressure to the valves, and an eccentric on the main shaft for operating said pumping devices.

14. In a motor, the combination of a crank-shaft, cylinders arranged around it, pistons in the cylinders, piston-rods connecting the pistons in pairs, said piston-rods being engaged by the crank-shaft, valves in the pistons, a cam for actuating them, supply-valve 45 devices arranged at the heads of the cylinders, levers for operating said valve devices, said levers being pivoted, a cam-wheel having an irregular peripheral groove that receives the ends of the levers and acts to vibrate them, pump-cylinders with their pistons and rods, an eccentric on the main shaft for actuating the pump-cylinders, and circular-arranged delivery-pipes for carrying the 55 impelling pressure to the supply-valve devices.

15. In a motor, the combination with a crank-shaft, of a plural arrangement of cylinders and their pistons, piston-rods connecting said pistons in pairs and having cross-slots at a right angle to their axes, valves in the pistons that are operated by slides whose edges are in the cross-slots, and means on the crank-shaft and working in the slots against 65 the slides for actuating the valves.

Signed at New York city this 22d day of March, 1901.

JOHN E. BLAKE.

Witnesses:

F. E. TASKER,
RITA BRADT.