



US00RE50004E

(19) **United States**
(12) **Reissued Patent**
Buckberry

(10) **Patent Number:** **US RE50,004 E**
(45) **Date of Reissued Patent:** **Jun. 11, 2024**

(54) **DUAL HAEMODIALYSIS AND HAEMODIAFILTRATION BLOOD TREATMENT DEVICE**

(58) **Field of Classification Search**
CPC A61M 1/168; A61M 1/154; A61M 1/155;
A61M 1/156; A61M 1/1562;

(71) Applicant: **Quanta Dialysis Technologies Ltd.**,
Warwickshire (GB)

(Continued)

(72) Inventor: **Clive Henry Buckberry**, Warwickshire
(GB)

(56) **References Cited**

(73) Assignee: **QUANTA DIALYSIS TECHNOLOGIES LTD.**,
Warwickshire (GB)

U.S. PATENT DOCUMENTS

2,696,173 A 12/1954 Thormod
3,338,171 A 8/1967 Conklin et al.

(Continued)

(21) Appl. No.: **17/345,754**

FOREIGN PATENT DOCUMENTS

(22) Filed: **Jun. 11, 2021**

CA 81430 8/1997
DE 10024447 A1 11/2001

(Continued)

Related U.S. Patent Documents

Reissue of:

(64) Patent No.: **10,314,959**
Issued: **Jun. 11, 2019**
Appl. No.: **14/911,846**
PCT Filed: **Aug. 13, 2014**
PCT No.: **PCT/GB2014/052486**
§ 371 (c)(1),
(2) Date: **Feb. 12, 2016**
PCT Pub. No.: **WO2015/022537**
PCT Pub. Date: **Feb. 19, 2015**

OTHER PUBLICATIONS

Ergo-Express Motorized Dialysis Cart, Aug. 14, 2017, youtube.com [online], [site visited Jan. 9, 2022], Available from internet, URL: <<https://www.youtube.com/watch?v=j4rAXthOmbY>> (Year: 2017).

(Continued)

Primary Examiner — Norca L. Torres Velazquez
(74) *Attorney, Agent, or Firm* — The Marbury Law Group, PLLC

(30) **Foreign Application Priority Data**

Aug. 14, 2013 (GB) 1314512

(57) **ABSTRACT**

(51) **Int. Cl.**
A61M 1/16 (2006.01)
A61M 1/14 (2006.01)

(Continued)

(52) **U.S. Cl.**
CPC **A61M 1/168** (2013.01); **A61M 1/154** (2022.05); **A61M 1/155** (2022.05); **A61M 1/156** (2022.05);

(Continued)

The invention relates to a blood treatment device, in particular a device which can perform haemodialysis and haemodiafiltration procedures. This is achieved using an interconnected pump and valve arrangement which can be controlled to direct fluid across a dialysis membrane or parallel to said membrane depending on the type of processing required. This allows dynamic variation between modes of operation and treatment.

45 Claims, 4 Drawing Sheets

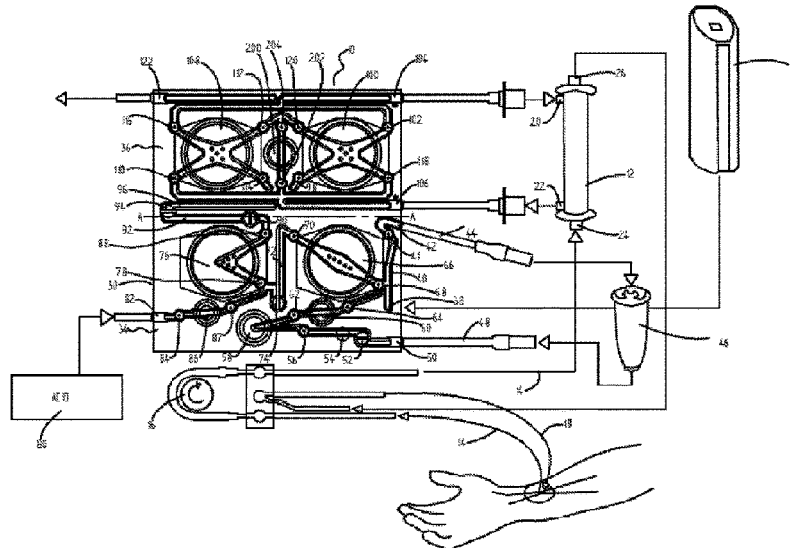

- (51) **Int. Cl.**
A61M 1/34 (2006.01)
A61M 1/36 (2006.01)
- (52) **U.S. Cl.**
 CPC *A61M 1/1562* (2022.05); *A61M 1/15632*
 (2022.05); *A61M 1/1565* (2022.05); *A61M*
1/16 (2013.01); *A61M 1/1645* (2014.02);
A61M 1/34 (2013.01); *A61M 1/3413*
 (2013.01); *A61M 1/342* (2013.01); *A61M*
1/3635 (2014.02); *A61M 1/1566* (2022.05);
A61M 2202/0413 (2013.01); *A61M 2205/128*
 (2013.01); *A61M 2205/33* (2013.01)
- (58) **Field of Classification Search**
 CPC .. *A61M 1/15632*; *A61M 1/1565*; *A61M 1/16*;
A61M 1/1645; *A61M 1/34*; *A61M*
1/3413; *A61M 1/342*; *A61M 1/3635*
 See application file for complete search history.
- (56) **References Cited**
 U.S. PATENT DOCUMENTS
- | | | | | | | | |
|-----------|---|---------|------------------|-----------|----|---------|--------------------|
| 3,468,261 | A | 9/1969 | Schmierer | 5,586,872 | A | 12/1996 | Skobelev et al. |
| 3,605,566 | A | 9/1971 | Vetter | 5,586,873 | A | 12/1996 | Novak et al. |
| 3,606,592 | A | 9/1971 | Madurski et al. | 5,591,344 | A | 1/1997 | Kenley et al. |
| 3,753,493 | A | 8/1973 | Mellor | 5,643,201 | A | 7/1997 | Peabody et al. |
| 3,774,762 | A | 11/1973 | Lichtenstein | 5,650,071 | A | 7/1997 | Brugger et al. |
| 3,807,906 | A | 4/1974 | Breit | 5,653,456 | A | 8/1997 | Mough |
| 3,921,622 | A | 11/1975 | Cole | 5,658,456 | A | 8/1997 | Kenley et al. |
| 3,972,320 | A | 8/1976 | Kalman | 5,665,307 | A | 9/1997 | Kirschner et al. |
| 4,070,725 | A | 1/1978 | Cornelius | 5,727,550 | A | 3/1998 | Montecalvo |
| 4,142,845 | A | 3/1979 | Lepp et al. | D395,085 | S | 6/1998 | Kenley et al. |
| 4,161,264 | A | 7/1979 | Malmgren | 5,788,851 | A | 8/1998 | Kenley et al. |
| 4,205,686 | A | 6/1980 | Harris et al. | 5,807,322 | A | 9/1998 | Lindsey et al. |
| 4,353,990 | A | 10/1982 | Manske et al. | 5,882,300 | A | 3/1999 | Malinouskas et al. |
| 4,366,061 | A | 12/1982 | Papanek et al. | 5,948,247 | A | 9/1999 | Gillerfalk et al. |
| 4,368,261 | A | 1/1983 | Klose et al. | 5,957,670 | A | 9/1999 | Duncan et al. |
| 4,370,983 | A | 2/1983 | Lichtenstein | 5,995,910 | A | 11/1999 | Discenzo |
| 4,430,048 | A | 2/1984 | Fritsch | 6,077,443 | A | 6/2000 | Goldau |
| 4,494,912 | A | 1/1985 | Pauliukonis | 6,126,831 | A | 10/2000 | Goldau et al. |
| D277,991 | S | 3/1985 | Becker | 6,132,378 | A | 10/2000 | Marino |
| 4,534,755 | A | 8/1985 | Calvert et al. | 6,143,181 | A | 11/2000 | Falkvall et al. |
| 4,534,756 | A | 8/1985 | Nelson | 6,153,102 | A | 11/2000 | Kenley et al. |
| 4,546,669 | A | 10/1985 | Fischer et al. | 6,216,029 | B1 | 4/2001 | Paltieli |
| 4,564,342 | A | 1/1986 | Weber et al. | 6,218,329 | B1 | 4/2001 | Singh et al. |
| 4,599,165 | A | 7/1986 | Chevallet | 6,251,279 | B1 | 6/2001 | Peterson et al. |
| 4,648,869 | A | 3/1987 | Bobo, Jr. | 6,261,065 | B1 | 7/2001 | Nayak et al. |
| 4,666,598 | A | 5/1987 | Heath et al. | 6,303,036 | B1 | 10/2001 | Collins et al. |
| 4,710,163 | A | 12/1987 | Butterfield | 6,382,923 | B1 | 5/2002 | Gray |
| 4,771,792 | A | 9/1988 | Seale | 6,514,462 | B1 | 2/2003 | Simons |
| 4,828,543 | A | 5/1989 | Weiss et al. | 6,558,347 | B1 | 5/2003 | Jhuboo et al. |
| 4,897,184 | A | 1/1990 | Shouldice et al. | 6,582,206 | B2 | 6/2003 | Schluecker |
| D308,249 | S | 5/1990 | Buckley | 6,626,832 | B1 | 9/2003 | Paltieli et al. |
| 4,969,991 | A | 11/1990 | Valadez | 6,626,878 | B1 | 9/2003 | Leisner et al. |
| 5,000,664 | A | 3/1991 | Lawless et al. | 6,645,176 | B1 | 11/2003 | Christenson et al. |
| 5,012,197 | A | 4/1991 | Seiffert et al. | 6,663,829 | B1 | 12/2003 | Kjellstrand |
| 5,032,265 | A | 7/1991 | Jha et al. | 6,733,476 | B2 | 5/2004 | Christenson et al. |
| 5,055,198 | A | 10/1991 | Shettigar | 6,743,204 | B2 | 6/2004 | Christenson et al. |
| 5,095,910 | A | 3/1992 | Powers | 6,801,646 | B1 | 10/2004 | Pena et al. |
| 5,103,211 | A | 4/1992 | Daoud et al. | 6,814,547 | B2 | 11/2004 | Childers et al. |
| 5,126,831 | A | 6/1992 | Nakagawara | 6,967,002 | B1 | 11/2005 | Edgson et al. |
| 5,232,434 | A | 8/1993 | Inagaki et al. | 7,040,142 | B2 | 5/2006 | Burbank |
| 5,252,213 | A | 10/1993 | Ahmad et al. | 7,107,837 | B2 | 9/2006 | Lauman et al. |
| D341,890 | S | 11/1993 | Sievert et al. | 7,153,286 | B2 | 12/2006 | Busby et al. |
| D344,339 | S | 2/1994 | Yoshikawa et al. | 7,220,358 | B2 | 5/2007 | Schacht et al. |
| 5,304,349 | A | 4/1994 | Polaschegg | 7,284,964 | B2 | 10/2007 | McDowell et al. |
| D347,896 | S | 6/1994 | Dickinson et al. | 7,383,721 | B2 | 6/2008 | Parsons et al. |
| D351,470 | S | 10/1994 | Scherer et al. | 7,434,312 | B2 | 10/2008 | Christenson et al. |
| 5,385,540 | A | 1/1995 | Abbott et al. | 7,494,590 | B2 | 2/2009 | Felding et al. |
| 5,421,823 | A | 6/1995 | Kamen et al. | 7,604,398 | B1 | 10/2009 | Akers et al. |
| 5,458,468 | A | 10/1995 | Ye et al. | 7,648,627 | B2 | 1/2010 | Beden et al. |
| 5,476,368 | A | 12/1995 | Rabenau et al. | 7,857,976 | B2 | 12/2010 | Bissler et al. |
| 5,476,792 | A | 12/1995 | Ezrielev et al. | 7,874,999 | B2 | 1/2011 | Busby |
| D370,979 | S | 6/1996 | Pascale et al. | 7,896,197 | B2 | 3/2011 | Furey et al. |
| 5,558,347 | A | 9/1996 | Nicholson | D641,882 | S | 7/2011 | Hickey et al. |
| | | | | 8,114,043 | B2 | 2/2012 | Muller |
| | | | | 8,132,388 | B2 | 3/2012 | Nagy et al. |
| | | | | 8,137,184 | B2 | 3/2012 | Ajiro et al. |
| | | | | 8,137,300 | B2 | 3/2012 | Han et al. |
| | | | | 8,167,431 | B2 | 5/2012 | DeCusatis et al. |
| | | | | 8,187,184 | B2 | 5/2012 | Muller et al. |
| | | | | 8,192,388 | B2 | 6/2012 | Hogard |
| | | | | 8,197,431 | B2 | 6/2012 | Bennison |
| | | | | 8,221,320 | B2 | 7/2012 | Bouton |
| | | | | 8,348,850 | B2 | 1/2013 | Frinak et al. |
| | | | | 8,360,977 | B2 | 1/2013 | Marttila et al. |
| | | | | 8,529,490 | B2 | 9/2013 | Wariar et al. |
| | | | | 8,535,522 | B2 | 9/2013 | Fulkerson et al. |
| | | | | 8,535,525 | B2 | 9/2013 | Heyes et al. |
| | | | | D693,469 | S | 11/2013 | Chung et al. |
| | | | | 8,597,505 | B2 | 12/2013 | Fulkerson et al. |
| | | | | D702,842 | S | 4/2014 | Hyde et al. |
| | | | | 8,685,244 | B2 | 4/2014 | Heyes et al. |
| | | | | 8,696,571 | B2 | 4/2014 | Marttila et al. |
| | | | | 8,708,908 | B2 | 4/2014 | Bouton |
| | | | | 8,708,946 | B2 | 4/2014 | Han et al. |
| | | | | D705,432 | S | 5/2014 | Lura et al. |
| | | | | 8,798,908 | B2 | 8/2014 | Bourdeaut |
| | | | | 8,801,646 | B2 | 8/2014 | Han et al. |
| | | | | D714,454 | S | 9/2014 | Amemiya et al. |
| | | | | D714,946 | S | 10/2014 | Lura et al. |

(56)

References Cited

U.S. PATENT DOCUMENTS

8,926,544 B2 1/2015 Hogard et al.
 D724,740 S 3/2015 Collins et al.
 8,974,394 B2 3/2015 Frinak et al.
 9,011,334 B2 4/2015 Bouton
 D735,868 S 8/2015 Mareguddi et al.
 9,220,825 B2 12/2015 Buckberry
 D781,410 S 3/2017 Ritter et al.
 9,744,285 B2 8/2017 Heyes et al.
 9,833,553 B2 12/2017 Higgitt et al.
 10,314,962 B2 6/2019 Buckberry
 10,456,516 B2 10/2019 Heyes et al.
 D867,597 S 11/2019 Bauer et al.
 10,543,305 B2 1/2020 Buckberry et al.
 D879,967 S 3/2020 Verguldi et al.
 D907,211 S 1/2021 Spurling
 10,881,775 B2 1/2021 Wallace
 10,960,120 B2 3/2021 Wallace et al.
 D924,410 S 7/2021 Mendoza et al.
 D938,046 S 12/2021 Gupta et al.
 11,365,728 B2 6/2022 Westenbrink
 11,571,499 B2 2/2023 Milad et al.
 11,583,618 B2 2/2023 Buckberry et al.
 2003/0217962 A1 11/2003 Childers et al.
 2004/0195157 A1 10/2004 Mullins et al.
 2004/0206703 A1 10/2004 Bosetto et al.
 2004/0215129 A1 10/2004 Edgson et al.
 2004/0223857 A1 11/2004 Kline
 2005/0020961 A1 1/2005 Burbank et al.
 2005/0205476 A1 9/2005 Chevallet et al.
 2005/0209547 A1 9/2005 Burbank et al.
 2005/0234384 A1 10/2005 Westberg
 2006/0121623 A1 6/2006 He et al.
 2007/0083193 A1 4/2007 Werneth et al.
 2008/0006089 A1 1/2008 Adnan et al.
 2008/0200865 A1 8/2008 Bedingfield
 2008/0283096 A1 11/2008 Scheringer et al.
 2009/0007642 A1 1/2009 Busby et al.
 2009/0009290 A1 1/2009 Kneip et al.
 2009/0012450 A1 1/2009 Shah et al.
 2009/0012452 A1 1/2009 Slepicka et al.
 2009/0012457 A1 1/2009 Childers et al.
 2009/0101550 A1 4/2009 Muller et al.
 2009/0211975 A1 8/2009 Brugger et al.
 2009/0230043 A1 9/2009 Heyes et al.
 2010/0043694 A1 2/2010 Patel
 2010/0045471 A1 2/2010 Meyers
 2010/0089807 A1 4/2010 Heyes et al.
 2010/0139254 A1 6/2010 Sebestyen et al.
 2010/0263687 A1 10/2010 Braun et al.
 2011/0009797 A1 1/2011 Kelly et al.
 2011/0034850 A1 2/2011 Jonsson
 2011/0132838 A1 6/2011 Curtis et al.
 2011/0168614 A1 7/2011 Pouchoulin et al.
 2012/0164022 A1 6/2012 Muginstein et al.
 2012/0269907 A1 10/2012 Coates
 2012/0273354 A1 11/2012 Orhan et al.
 2012/0276549 A1 11/2012 Cunningham et al.
 2012/0292237 A1 11/2012 Heyes et al.
 2012/0308431 A1 12/2012 Kotsos et al.
 2013/0037465 A1 2/2013 Heyes et al.
 2013/0056419 A1 3/2013 Curtis
 2013/0092361 A1 4/2013 Wrazel et al.
 2013/0153495 A1 6/2013 Kelly et al.
 2013/0199998 A1 8/2013 Kelly et al.
 2013/0213891 A1* 8/2013 Karoor A61M 1/287
 2013/0274642 A1 10/2013 Soykan et al.
 2014/0224736 A1 8/2014 Heide
 2014/0251885 A1 9/2014 Heyes
 2014/0271106 A1 9/2014 Alessandro et al.
 2014/0299544 A1 10/2014 Wilt et al.
 2015/0027951 A1 1/2015 Wallace et al.
 2015/0076053 A1 3/2015 Higgitt et al.
 2015/0112119 A1 4/2015 Buckberry
 2015/0129481 A1 5/2015 Higgitt et al.

2015/0238673 A1 8/2015 Gerber et al.
 2015/0258263 A1 9/2015 Hogard
 2015/0352269 A1 12/2015 Gerber et al.
 2015/0359954 A1 12/2015 Gerber et al.
 2016/0045656 A1 2/2016 Buckberry
 2016/0051743 A1 2/2016 Buckberry
 2016/0058933 A1 3/2016 Ballantyne et al.
 2016/0076535 A1 3/2016 Clifton et al.
 2016/0077644 A1 3/2016 Ritter et al.
 2017/0056576 A1 3/2017 Doyle et al.
 2017/0167983 A1 6/2017 Klomp et al.
 2017/0252498 A1 9/2017 Heyes et al.
 2017/0296730 A1 10/2017 Soto et al.
 2018/0133391 A1 5/2018 Heyes et al.
 2018/0154059 A1 6/2018 Heyes et al.
 2018/0193545 A1 7/2018 Crnkovich et al.
 2018/0344915 A1 12/2018 Wallace
 2019/0001042 A1 1/2019 Buckberry
 2019/0015577 A1 1/2019 Garrido et al.
 2019/0024654 A1 1/2019 May et al.
 2019/0358381 A1 11/2019 Westenbrink
 2019/0374698 A1 12/2019 Buckberry et al.
 2019/0376504 A1 12/2019 Westenbrink
 2019/0385434 A1 12/2019 Yuds et al.
 2020/0030515 A1 1/2020 Merchant
 2020/0075159 A1 3/2020 Bardorz et al.
 2020/0268958 A1 8/2020 Heyes et al.
 2020/0276372 A1 9/2020 Milad et al.
 2020/0330671 A1 10/2020 Buckberry et al.
 2021/0110920 A1 4/2021 Heyes et al.
 2022/0001087 A1 1/2022 Heyes et al.
 2022/0160943 A9 5/2022 Buckberry et al.
 2022/0241480 A1 8/2022 Fincham
 2022/0241573 A1 8/2022 Fincham

FOREIGN PATENT DOCUMENTS

EM 004375764-0001 10/2017
 EM 004375764-0002 10/2017
 EM 007955125-0002 6/2020
 EP 0165751 A2 12/1985
 EP 0754468 A2 1/1997
 EP 1 982 737 A1 10/2008
 EP 2219703 A1 8/2010
 EP 2955512 A1 12/2015
 FR 2 310 136 12/1976
 GB 9007955125-0001 5/2020
 GB 9007955125-0002 5/2020
 JP H04266740 9/1992
 JP H06261872 9/1994
 JP H07174659 7/1995
 JP 2000/130334 5/2000
 JP D1645323 11/2020
 WO WO 81/01800 7/1981
 WO WO 91/00113 1/1991
 WO WO 91/16542 10/1991
 WO WO 95/06205 3/1995
 WO WO 95/25893 9/1995
 WO WO 96/25214 8/1996
 WO WO 97/10013 3/1997
 WO WO 97/28368 8/1997
 WO WO 99/29356 6/1999
 WO WO 2000/006217 2/2000
 WO WO 00/57935 10/2000
 WO WO 02/066833 8/2002
 WO WO 02/081917 10/2002
 WO WO 2003/101510 12/2003
 WO WO 2005/044339 5/2005
 WO WO 2005/044339 A2 5/2005
 WO WO 2005/080794 9/2005
 WO WO 2006/120415 11/2006
 WO WO 2006/120417 11/2006
 WO WO 2008/100671 8/2008
 WO WO 2008/106191 9/2008
 WO WO 2008/135245 11/2008
 WO WO 2009/006489 1/2009
 WO WO 2009/006489 A2 1/2009
 WO WO 2009/024333 2/2009
 WO WO 2009/038834 3/2009

(56)

References Cited

FOREIGN PATENT DOCUMENTS

WO	WO 2009/061608	5/2009
WO	WO 2009/127624	10/2009
WO	WO 2010/089130	8/2010
WO	WO 2010/146343	12/2010
WO	WO 2011/027118	3/2011
WO	WO 2011/068885	6/2011
WO	WO 2011/068885 A1	6/2011
WO	WO 2011/105697	9/2011
WO	WO 2011/105697 A2	9/2011
WO	WO 2011/105698	9/2011
WO	WO 2011/105698 A2	9/2011
WO	WO 2013/052680	4/2013
WO	WO 2013/052680 A2	4/2013
WO	WO 2013/057109	4/2013
WO	WO 2013/110906	8/2013
WO	WO 2013/110919	8/2013
WO	WO 2013/114063	8/2013
WO	WO 2013/114063 A1	8/2013
WO	WO 2013/121162	8/2013
WO	WO 2013/121163	8/2013
WO	WO 2014/072195	5/2014
WO	WO 2014/082855	6/2014
WO	WO 2014/155121	10/2014
WO	WO 2015/007596	1/2015
WO	WO 2015/022537	2/2015
WO	WO 2016/016870	2/2016
WO	WO 2017/137723	8/2017
WO	WO 2018/115816	6/2018

OTHER PUBLICATIONS

He et al., "A Fluorescent Sensor with High Selectivity and Sensitivity for Potassium in Water," *Journal of the American Chemical Society* 2003 125 (6), 1468-1469.

Home Dialysis Tescon Aqua Tech, Aug. 1, 2020, youtube.com [online], [site visited Jan. 9, 2022], Available from internet, URL: <https://www.youtube.com/watch?v=WLLPZoS_mz4> (Year: 2020).

Kivi, Air Embolism, Healthline, Aug. 20, 2012, p. 1-5.

LHO2028 Portable Hemodialysis Machine, date unknown, aliexpress.com [online], [site visited Jan. 4, 2022], Available from internet: <https://www.aliexpress.com/item/1005003324875329.html?randl_currency=USD&_randl_shipto=US&src=google&afffcid=1003bab3b8db4e93b9ba88522a14cfc1-1641319351626-05232-UneMJZVf&aff_fsk=UneMJZVf&aff_platform=aaf&sk=UneMJZVf&aff_trace_key=> (Year: 2022).

Medical Hemodialysis Machine, date unknown, aliexpress.com [online], [site visited Jan. 4, 2022], Available from internet: <https://www.aliexpress.com/item/1005003445721549.html?_randl_currency=USD&_randl_shipto=US&src=google&aff_fcid=a524f3f9cd9b4976b6b47962f3439d62-1641319166409-02691-UneMJZVf&aff_fsk=UneMJZVf&aff_platform=aaf&sk=UneMJZVf&aff_trace_key=a524f3f9cd9b4976b6b47962f3439d62-1641319166409-02691-UneMJZVf&terminal_id=d0c2cca4b7664d128cb4801a9ef03ff2> (Year: 2022).

Millenium HX Portable Dialysis Water System, Jul. 2, 2014, youtube.com [online], [site visited Jan. 10, 2022], Available from internet, URL: <<https://www.youtube.com/watch?v=IGEbPi2CDsw>> (Year: 2014).

Portable home dialysis device, Nov. 2, 2017, med-technews.com [online], [site visited Jan. 4, 2022], Available from internet: <<https://www.med-technews.com/news/portable-home-dialysis-device-to-launch-next-year/>> (Year: 2017).

Lee et al., "Evaluation of a New Method for Pulse Push/Pull Hemodialysis: Comparison with Conventional Hemodialysis," *ASAIO Journal* 2012, pp. 232-237.

Kyungsoo Lee, "Pulse Push/Pull Hemodialysis: Convective Renal Replacement Therapy," *Progress in Hemodialysis—From Emergent Biotechnology to Clinical Practice*, Chap. 6, pp. 113-142 (Intech 2011).

Kyungsoo Lee, "Push/Pull Based Renal Replacement Treatments," *Hemodialysis*, Chap. 22, pp. 455-474 (Intech 2013).

Jan. 5, 2015 ISR for PCT/GB2014/052486.

Feb. 16, 2016 International Preliminary Report on Patentability for PCT/GB2014/052486.

* cited by examiner

Figure 1

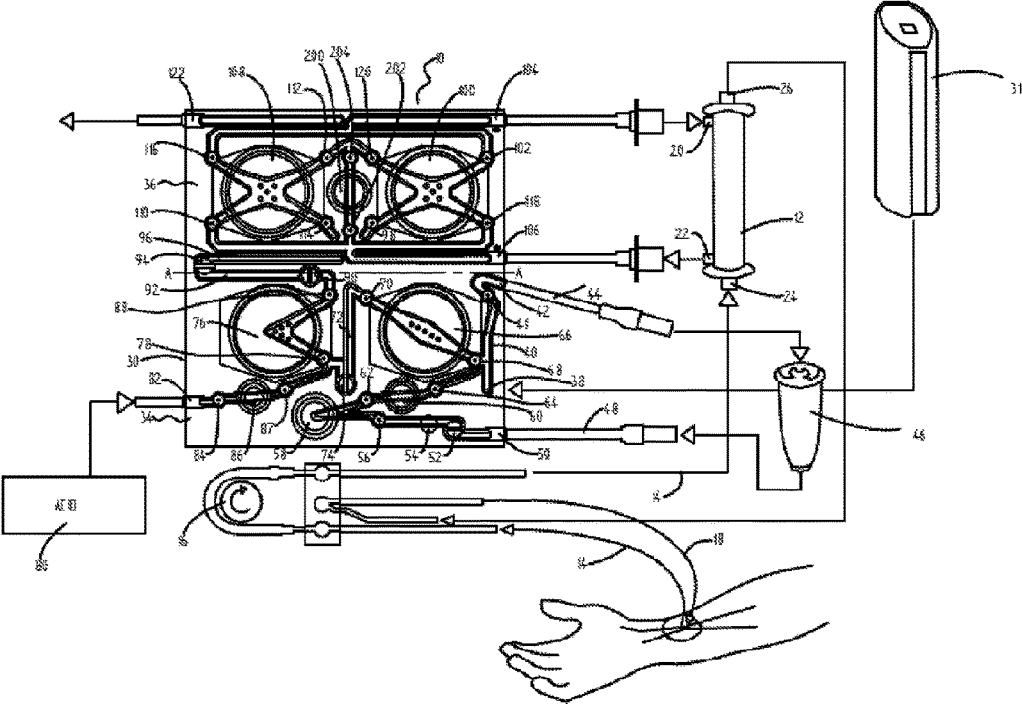

Figure 2

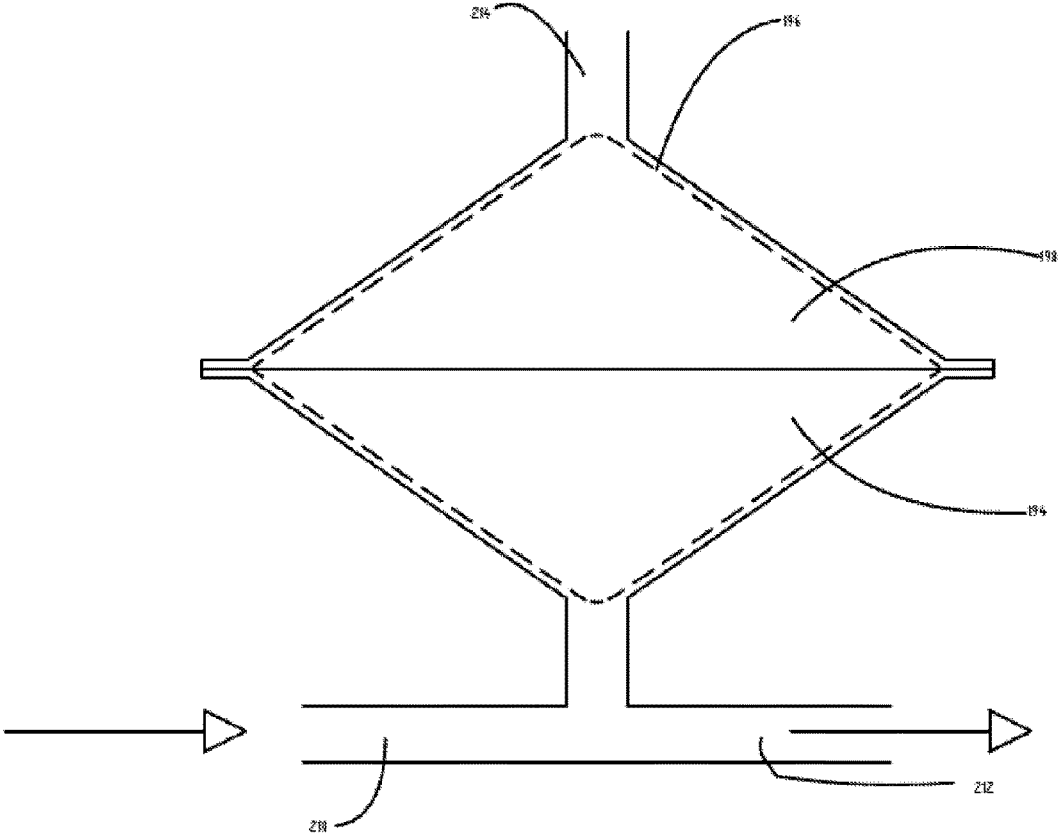
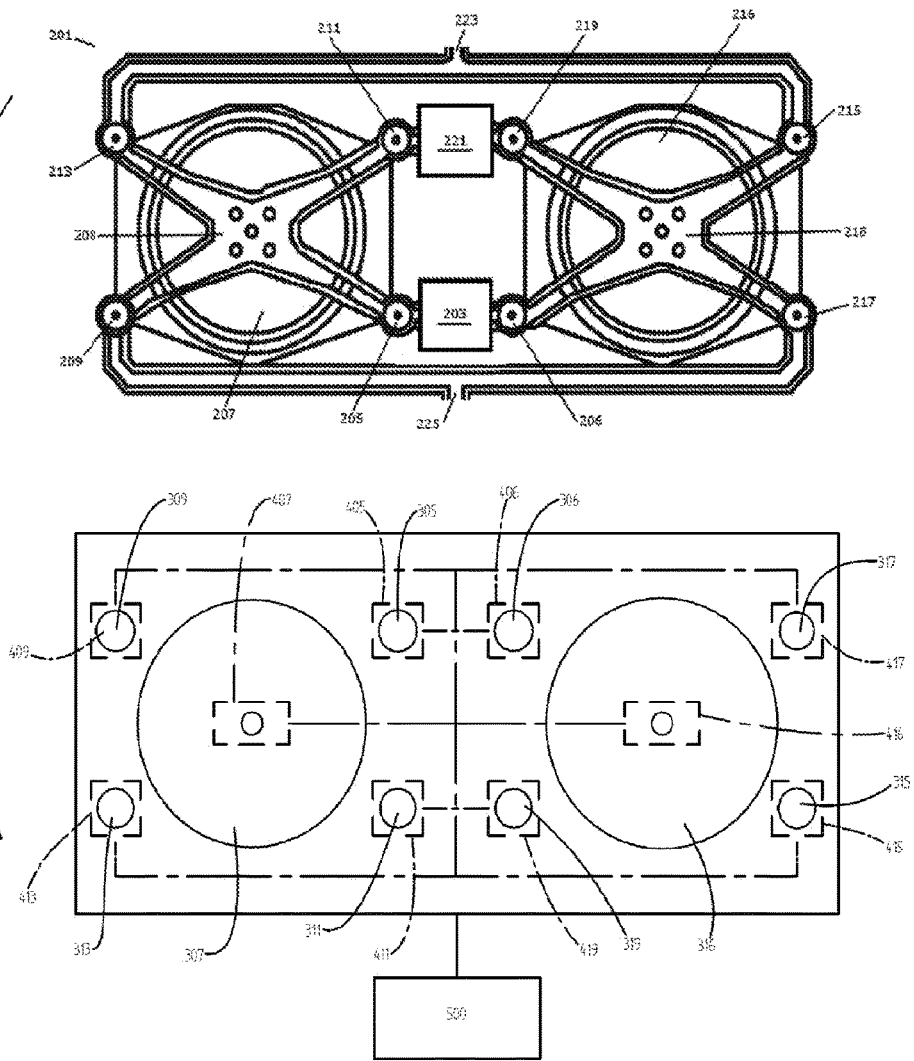

Figure 3



DUAL HAEMODIALYSIS AND HAEMODIAFILTRATION BLOOD TREATMENT DEVICE

Matter enclosed in heavy brackets [] appears in the original patent but forms no part of this reissue specification; matter printed in italics indicates the additions made by reissue; a claim printed with strikethrough indicates that the claim was canceled, disclaimed, or held invalid by a prior post-patent action or proceeding.

The present application is a *reissue patent application of U.S. Pat. No. 10,314,959, which issued 11 Jun. 2019, from U.S. patent application Ser. No. 14/911,846, filed 12 Feb. 2016, which is a 35 USC § 371 submission of international application no. PCT/GB2014/052486, filed on 13 Aug. 2014 and published in the English language on 19 Feb. 2015 with publication no. WO 2015/022537 A1, which claims the benefit of the filing date of application no. GB 1314512.3, filed 14 Aug. 2013, the disclosures of which are incorporated by reference.*

FIELD OF INVENTION

The invention relates to a blood treatment device capable of performing both hemodialysis and hemodiafiltration and methods of operating the device making it suitable for use in both types of treatment.

BACKGROUND TO THE INVENTION

Patients suffering from kidney disorders rely on a variety of external blood treatments to remove the harmful waste substances that build up in their blood over time. One of the most common methods of treatment is hemodialysis.

Hemodialysis typically involves two networks of fluid passageways [miming] *running* adjacent to one another in a counter current flow arrangement. Blood is passed through one set of tubules and a cleaning solution is passed through the other. The pH and osmotic potential of the cleaning solution is adapted such that waste compounds built up in the blood diffuse from the blood into the cleaning solution via a semi permeable membrane which separates the blood and cleaning solution sides of the network of fluid passageways.

This provides a method of gradually removing waste materials from the blood minimising fatigue to the patient. However, there are some disadvantages associated with hemodialysis not present with other forms of blood treatment.

Many mid-size and large-size waste solutes dissolved in the blood (including such as proteins and polypeptides) are difficult to remove completely from the blood using diffusion alone and it can take a long time to reduce the levels of these substances in the blood to acceptable levels. An alternative approach is to use hemodiafiltration.

Hemodiafiltration involves administering sterile cleaning solution to the blood either by employing a large hydrostatic potential to force sterile cleaning solution across a semi permeable membrane into the blood or by directly adding it to the blood; and then pulling the sterile cleaning solution, complete with dissolved waste products, back across the semi permeable membrane for subsequent disposal.

Examples of hemodiafiltration machines are disclosed in, for example "Lee, K., et al., Evaluation of a New Method for

Pulse Push/Pull Hemodialysis: Comparison with Conventional Hemodialysis, ASAIO Journal, 2012, page 232-237".

This type of blood treatment is not limited by diffusion as sterile cleaning solution is allowed to mix directly with the blood. However, the rapid extraction of waste products from a patient's blood regularly leaves patients fatigued.

Accordingly, what is required is a device which is able to facilitate both methods of blood treatment during the same treatment session based on the patients specific requirements.

SUMMARY OF THE INVENTION

In a first aspect of the invention, there is provided a blood treatment device comprising: a dialyzer; a first pump for delivering a volume of cleaning solution from a cleaning solution source to the dialyzer; a second pump for removing a volume of cleaning solution from the dialyzer and delivering said cleaning solution to a drain; a first dialyzer inlet valve arranged between the first pump and an inlet of the dialyzer; a first dialyzer outlet valve arranged between an outlet of the dialyzer outlet and the second pump; each of the valves and the pumps being independently operable; and a control system configured to operate the valves and pumps in at least one first mode permitting hemodialysis and at least one second mode permitting hemodiafiltration.

The inventors have found that by using an arrangement according to the first aspect of the invention, it is possible to operate the pumps and valves to allow cleaning solution to be forced across and back through the membrane of the dialyzer to the blood as well as operate the pumps and valves to pump cleaning solution through the dialyzer in a conventional manner to permit diffusion from the blood into the cleaning solution across the semi permeable membrane down a concentration gradient. This allows for one apparatus to serve a dual purpose and means that a mix of both hemodialysis and hemodiafiltration treatments can be provided to a patient during a single session. This allows the treatment to be tailored to minimise the duration of dialysis whilst managing the fatigue levels of the patient.

The term "configured to" with reference to the control system of the invention is intended to mean that the control system is either programmed or physically arranged to operate the valves and pumps in a specific manner. The control system is programmable or configurable to operate the pumps and valves in a specific manner. The control system may be a microprocessor programmed to control the operation of the pumps and valves to effect the hemodialysis or hemodiafiltration.

Alternatively, the control system may be a mechanical arrangement which actuates the pumps and valves in a particular way to effect hemodialysis or hemodiafiltration.

In either case, switching between modes of operation may be automatic or may be effected manually.

Where the control system is a microprocessor, the control system may be adapted and/or configured to receive data corresponding to levels of waste components in the blood and, based on the data, moderate the amount of hemodialysis and hemodiafiltration of the blood treatment procedure accordingly.

Typically, the pumps used in the invention are positive displacement pumps, using pumping systems with an "in stroke" for taking in a solution to be pumped and an "out stroke" for expelling the solution out again is useful to maintain flow balance.

Preferably, the positive displacement pumps are membrane pumps. The membrane pumps typically comprise a

3

chamber which is adapted to hold a volume of solution and a membrane sealing the chamber. The membrane can be forced down into the chamber to expel the solution from the chamber. The membrane is often a flexible membrane and is typically fabricated from an elastic material. The elastic material is often made from a plastic or polymeric material and typically forms a film sealing one end of the chamber. The membrane may extend substantially over all the chambers used in the device or each membrane pump may comprise a separate membrane in communication with the chambers.

Preferably, the pumps are arranged to pump a predetermined volume of cleaning solution. Typically the pumps used in the invention are adapted to pump the same volume of solution. Where the pumps are positive displacement pumps, the pumps are adapted to pump the same volume of solution in each single stroke. This ensures that the amount of solution pumped into the dialyzer by the first pump is the same as the amount of solution drawn from the dialyzer by the second pump.

In a further embodiment, the device may comprise one or more sensors arranged to monitor the blood pressure of the user, said sensors being in communication with the control means and wherein the control means may be additionally configured to modify the pressure of the cleaning solution generated by the pumps based on the blood pressure of the user.

This allows for fluctuations in the patient's blood pressure to be accounted for to ensure substantially constant volumetric pumping.

Keeping cleaning solution pressure and blood pressure balanced ensures consistent valve closure using the membrane and helps maintain a constant rate of blood treatment.

The dialyzer used in the invention may be a separate dialyzer device to which the machine and/or cartridge is attached or alternatively, the dialyzer may be formed on the cartridge.

The device may comprise a first cleaning solution source valve arranged between the cleaning solution source and the first pump. This ensures that when the first pump is operated to pump cleaning solution into the dialyzer no cleaning solution is able to return back towards the cleaning solution source. The device may comprise a first drain valve arranged between the second pump and the drain. This prevents the spent cleaning solution from being drawn back from the drain when the second pump is operated. The cleaning solution used in the invention is typically dialysate. The dialysate solution may be passed through one or more sterilisation means. The sterilisation means may be present in the machine. As the cleaning solution is made to enter the blood, the solution must be substantially free of pathogens.

Typically, the first pump and second pump are both operable to deliver a volume of cleaning solution from a cleaning solution source to the dialyzer and remove a volume of cleaning solution from the dialyzer, deliver said cleaning solution to a drain. Adapting both pumps to function in this way allows the roles of each pump to be periodically swapped. This is usually done at regular intervals in order to negate any small manufacturing discrepancies in the volume of the pump chambers.

The device may further comprise a second dialyzer inlet valve arranged between the second pump and the inlet of the dialyzer and a second dialyzer outlet valve arranged between the outlet of the dialyzer and the first pump. The device preferably comprises a second cleaning solution source valve arranged between the cleaning solution source and the second pump. The device may comprise a second drain

4

valve arranged between the first pump and the drain. These valves ensure that no cleaning solution is pumped in the wrong direction.

The control system is preferably configured, in use, to alternate the operation of the valves and pumps between the at least one first mode and the at least one second mode. The valves and pumps may be independently operable to perform a mixture of blood treatment operations in a single blood treatment session.

In a preferred embodiment, the control system is configured to alternate the pump responsible for delivering cleaning solution to the dialyzer and the pump responsible for removing spent cleaning solution from the dialyzer after a given number of pumping cycles. The first pump may initially operate as the pump responsible for delivering cleaning solution to the dialyzer and the second pump may be responsible for removing spent cleaning solution from the dialyzer. As both the first and second pumps may be connected to the drain and cleaning solution source, these roles can be switched in order to accommodate minor discrepancies in the volumes of the pump chambers.

Typically, the number of pumping cycles may be two or more pumping cycles. The term "pumping cycle" is intended to refer to the sequence of operations required to pump one pump's volume of cleaning solution from the cleaning solution source and into the drain.

The pumps and valves may be formed on a disposable cartridge. Typically the cleaning solution source, pumps, valves and fluid passageways are all contained on the cartridge.

In a second aspect of the invention, there is provided a method of operating a device according to the first aspect of the invention, wherein the valves and pumps are operated in the at least one first mode permitting hemodialysis and the at least one second mode permitting hemodiafiltration.

The valves and pumps may be operated to alternate between the at least one first mode permitting hemodialysis and the at least one second mode permitting hemodiafiltration. Having a single device capable of operating in two modes to facilitate two methods of blood treatment provides a more versatile device removing the requirement to have two machines adapted to do different tasks. Further, switching between two different methods of blood treatment during a treatment session improves the process of cleaning a patient's blood.

Alternatively, there is provided a method of operating the device according to the first aspect of the invention, wherein the valves and pumps are operated in the at least one second mode permitting hemodiafiltration. Making use of an arrangement comprising two pumps allows for a method of operating a blood treatment device that allows hemodiafiltration to be performed in a pump cycle comprising only two stages. This increases the rate of flow of cleaning solution that can be passed through the dialyzer membrane allowing for faster hemodiafiltration compared to existing devices.

Typically, the at least one first mode comprises the steps of: a) operating the first pump to draw the cleaning solution from a cleaning solution source into the first pump and operating the second pump to expel spent cleaning solution from the second pump into the drain; and b) operating the first pump to expel the cleaning solution from a first pump into the dialyzer and operating the second pump to draw spent cleaning solution from the dialyzer into the second pump.

In this mode of operation, cleaning solution is passed from the first pump and into the second pump through the dialyzer allowing waste product from the blood to enter the

5

cleaning solution via diffusion across the semi permeable membrane in the dialyzer. The cleaning solution does not pass substantially across the dialyzer membrane as it is preferentially drawn into the second pump as a result of the generated negative pressure.

The first mode may comprise the steps of: a) closing the first dialyzer inlet valve, closing the first dialyzer outlet valve, operating the first pump to draw the volume of cleaning solution from a cleaning solution source into the first pump and operating the second pump to expel the volume of cleaning solution from the second pump into the drain; and b) opening the first dialyzer inlet valve, opening the first dialyzer outlet valve, operating the first pump to expel the volume of cleaning solution from the first pump into the dialyzer and operating the second pump to draw the volume of cleaning solution from the dialyzer into the second pump.

The first mode preferably comprises the steps of: a) closing the first dialyzer inlet valve, closing the first dialyzer outlet valve, opening the first clean solution source valve, opening the first drain valve, operating the first pump to draw the volume of cleaning solution from a cleaning solution source into the first pump and operating the second pump to expel the volume of cleaning solution from the second pump into the drain; and b) opening the first dialyzer inlet valve, opening the first dialyzer outlet valve, closing the first clean solution source valve, closing the first drain valve, operating the first pump to expel the volume of cleaning solution from the first pump into the dialyzer and operating the second pump to draw the volume of cleaning solution from the dialyzer into the second pump.

The first mode may comprise the steps of: a) closing the first and second dialyzer inlet valve, closing the first and second dialyzer outlet valve, opening the first cleaning solution source valve, opening the first drain valve, closing the second cleaning solution source valve, closing the second drain valve, operating the first pump to draw the volume of cleaning solution from a cleaning solution source into the first pump and operating the second pump to expel the volume of cleaning solution from the second pump into the drain; b) opening the first dialyzer inlet valve, opening the first dialyzer outlet valve, closing the first clean solution source valve, closing the first drain valve, operating the first pump to expel the volume of cleaning solution from the first pump into the dialyzer and operating the second pump to draw the volume of cleaning solution from the dialyzer into the second pump; c) closing the first dialyzer inlet valve, closing the first dialyzer outlet valve, opening the first drain valve, operating the second pump to expel the volume of cleaning solution from the second pump into the drain; and d) closing the first drain valve, opening the second cleaning solution source valve, operating the second pump to draw the volume of cleaning solution from the clean solution source; e) opening the second dialyzer inlet valve, opening the second dialyzer outlet valve, closing the second cleaning solution source valve, operating the second pump to expel the volume of cleaning solution from the second pump into the dialyzer and operating the first pump to draw the volume of cleaning solution from the dialyzer into the first pump; f) closing the second dialyzer outlet valve, opening the second drain valve, closing the second dialyzer inlet valve, opening the second cleaning solution source valve, operating the second pump to draw the volume of cleaning solution from the cleaning solution source and operating the first pump to expel the volume of cleaning solution from the first pump into the drain.

6

Operating the device in a first mode as described above by swapping the roles of the first and second pumps removes error in the volume of liquid pumped due to inherent, small differences in the first and second pumps resulting from their manufacture.

Usually, the first mode comprises a pumping cycle as described above further comprising an additional step between steps b) and c), wherein the additional step comprises repeating steps a) and b) one or more times.

It may be the case that the first mode comprises a pumping cycle comprising an additional step after step f), the additional step comprising repeating steps e) and f) one or more times.

Typically, the at least one second mode comprises the steps of: a) operating the first pump to draw the volume of cleaning solution from a cleaning solution source into the first pump and operating the second pump to draw a volume of cleaning solution from the dialyzer into the second pump; and b) operating the first pump to expel the volume of cleaning solution from the first pump into the dialyzer and operating the second pump to expel the volume of cleaning solution from the second pump into the drain.

In use, these steps may be repeated continuously throughout the duration of a treatment session.

Operating the pumps and valves in this manner forces cleaning solution across the dialyzer membrane and into the blood with the first step and pulls the cleaning solution back across the dialyzer in the second step thereby effecting hemodiafiltration in a two step pumping cycle.

Typically, the second mode may comprise a pumping cycle comprising the steps of: a) closing the first dialyzer inlet valve, opening the first dialyzer outlet valve, operating the first pump to draw the volume of cleaning solution from a cleaning solution source into the first pump and operating the second pump to draw the volume of cleaning solution from the dialyzer into the second pump; and b) opening the first dialyzer inlet valve, closing the first dialyzer outlet valve, operating the first pump to expel the volume of cleaning solution from the first pump into the dialyzer and operating the second pump to expel the volume of cleaning solution from the second pump into the drain.

Even more typically, the second mode may comprise a pumping cycle comprising the steps of: a) closing the first dialyzer inlet valve, opening the first dialyzer outlet valve, opening the first cleaning solution source valve, closing the first drain valve, operating the first pump to draw the volume of cleaning solution from a cleaning solution source into the first pump and operating the second pump to draw the volume of cleaning solution from the dialyzer into the second pump; and b) opening the first dialyzer inlet valve, closing the first dialyzer outlet valve, closing the first cleaning solution source valve, opening the first drain valve, operating the first pump to expel the volume of cleaning solution from the first pump into the dialyzer and operating the second pump to expel the volume of cleaning solution from the second pump into the drain.

Usually, the second mode may comprise a pumping cycle comprising the steps of: a) closing the first and second dialyzer inlet valve, opening the first dialyzer outlet valve, closing the second dialyzer outlet valve, opening the first cleaning solution source valve, closing the second cleaning solution source valve, closing the first and second drain valves, operating the first pump to draw the volume of cleaning solution from a cleaning solution source into the first pump and operating the second pump to draw the volume of cleaning solution from the dialyzer into the second pump; b) opening the first dialyzer inlet valve,

closing the first dialyzer outlet valve, closing the first cleaning solution source valve, opening the first drain valve, operating the first pump to expel the volume of cleaning solution from the first pump into the dialyzer and operating the second pump to expel the volume of cleaning solution from the second pump into the drain; c) closing the first dialyzer inlet valve, opening the second dialyzer outlet valve, opening the second cleaning solution source valve, closing the first drain valve, operating the second pump to draw the volume of cleaning solution from a cleaning solution source into the second pump and operating the first pump to draw the volume of cleaning solution from the dialyzer into the first pump; and d) opening the second dialyzer inlet valve, closing the first and second dialyzer outlet valves, closing the first cleaning solution source valve, opening the second drain valve, operating the first pump to expel the volume of cleaning solution from the first pump into the drain and operating the second pump to expel the volume of cleaning solution from the second pump into the dialyzer.

Operating the device in the second mode as described above by swapping the roles of the first and second pumps, removes error in the volume of liquid pumped due to inherent, small differences in the first and second pumps resulting from their manufacture.

In addition, by incorporating hemodiafiltration steps into a hemodialysis treatment session, proteins and other large molecules built up on the dialyzer membrane can be dislodged and/or dissolved by periodically incorporating a hemodiafiltration operation into an otherwise purely hemodialysis operating method. This ensures the sieving coefficient of the membrane can be maintained at an optimum level thereby ensuring the dialyzer membrane does not become "clogged".

Typically, the method further comprises an additional step between steps b) and c), wherein the additional step comprises repeating steps a) and b) one or more times. Even more typically, the method comprises an additional step after step d), wherein the additional step comprises repeating steps c) and d) one or more times.

In an alternative embodiment, the device can be configured wherein the second mode comprises the steps of: a) closing the first dialyzer inlet valve, opening the first dialyzer outlet valve, operating the second pump to draw the volume of cleaning solution from the dialyzer into the second pump; b) closing the first dialyzer outlet valve, operating the first pump to draw the volume of cleaning solution from the cleaning solution source into the first pump and operating the second pump to expel the volume of cleaning solution from the second pump into the drain; and c) opening the first dialyzer inlet valve, operating the first pump to expel the volume of cleaning solution from the first pump into the dialyzer.

Further, by operating the second mode in this manner there is no requirement for the sensors to be used to monitor the quantity of cleaning solution entering the patient as this can be accurately determine by counting the number of pump cycles. Further, operating the device in this way is particularly useful as a supplementary treatment technique to hemodialysis. The transfer of cleaning solution across the membrane improves dissolution of larger waste molecules which do not pass through the membrane easily during pure hemodialysis. These molecules can be removed more easily as this cleaning solution in the blood is pulled back across the dialyzer membrane and delivered to the drain. The ratio of hemodiafiltration to hemodialysis used in a single treatment is typically in the range of 5% to 95% hemodiafiltra-

tion, 10% to 85% hemodiafiltration, 20% to 80% hemodiafiltration and is most typically between 25% to 75% hemodiafiltration.

Although the amount of hemodiafiltration can be varied to suit a particular patient's requirements, it is usually the case that in a typical treatment session, the amount of cleaning solution that passes across the dialyzer membrane via diafiltration is in the range of 15 to 35 liters, or more typically in the range of 20 to 30 liters.

In another alternative embodiment, the second mode may comprise the steps of: a) closing the first dialyzer inlet valve, opening the first dialyzer outlet valve, closing the first drain valve, operating the second pump to draw the volume of cleaning solution from the dialyzer into the second pump; b) closing the first dialyzer outlet valve, opening the first cleaning solution source valve, opening the first drain valve, operating the first pump to draw the volume of cleaning solution from the cleaning solution source into the first pump and operating the second pump to expel the volume of cleaning solution from the second pump into the drain; and c) opening the first dialyzer inlet valve, closing the first cleaning solution source valve, operating the first pump to expel the volume of cleaning solution from the first pump into the dialyzer.

Preferably, the second mode comprises the steps of: a) opening the first cleaning solution source valve, operating the first pump to draw the volume of cleaning solution from the cleaning solution source into the first pump and operating the second pump to expel the volume of cleaning solution from the second pump into the drain; b) opening the first dialyzer inlet valve, operating the first pump to expel the volume of cleaning solution from the first pump into the dialyzer; and c) closing the first dialyzer inlet valve, opening the first dialyzer outlet valve, operating the second pump to draw the volume of cleaning solution from the dialyzer into the second pump.

More preferably, the second mode comprises the steps of: a) closing the first dialyzer outlet valve, opening the first cleaning solution source valve, opening the first drain valve, operating the first pump to draw the volume of cleaning solution from the cleaning solution source into the first pump and operating the second pump to expel the volume of cleaning solution from the second pump into the drain, b) opening the first dialyzer inlet valve, closing the first cleaning solution source valve, operating the first pump to expel the volume of cleaning solution from the first pump into the dialyzer; and c) closing the first dialyzer inlet valve, opening the first dialyzer outlet valve, closing the first drain valve, operating the second pump to draw the volume of cleaning solution from the dialyzer into the second pump.

The second mode may comprise the steps of: a) closing the first dialyzer outlet valve, opening the first cleaning solution source valve, opening the first drain valve, operating the first pump to draw the volume of cleaning solution from the cleaning solution source into the first pump and operating the second pump to expel the volume of cleaning solution from the second pump into the drain; b) opening the first dialyzer inlet valve, closing the first cleaning solution source valve, operating the first pump to expel the volume of cleaning solution from the first pump into the dialyzer; c) closing the first dialyzer inlet valve, opening the first dialyzer outlet valve, closing the first drain valve, operating the second pump to draw the volume of cleaning solution from the dialyzer into the second pump; d) opening the first drain valve, closing the first dialyzer outlet valve, operating the second pump to expel the cleaning solution from the second pump into the drain; e) closing the first drain valve, opening the second source valve, closing the second dialyzer inlet valve and operating the second pump to draw a volume

cleaning solution from the cleaning solution source into the second pump; f) closing the second source valve, opening the second dialyzer inlet valve and operating the second pump to expel the volume of cleaning solution from the second pump into the dialyzer; g) closing the second dialyzer inlet, opening the second dialyzer outlet, closing the second drain valve and operating the first pump to draw the volume of cleaning solution into the first pump; and h) opening the second drain valve, closing the second dialyzer outlet valve, opening the second source valve and operating the first pump to expel the volume of cleaning solution from the first pump into the drain and operating the second pump to draw a volume of cleaning from the source into the second pump.

The method may comprise the step in between steps c) and d) of repeating steps a) to c) one or more times. Further, it may be the method comprises the step after step h) of repeating steps f) to h) one or more times. Usually, these steps a) to c) and steps f) to h) are repeated once.

In a still further embodiment of the invention, the second mode may comprise the steps of: a) operating both the first and second to draw a volume of cleaning solution from a cleaning solution source into the first and second pumps; b) operating both pumps to expel the volume of cleaning solution into the dialyzer and across the membrane of the dialyzer; c) operating the first and second pumps to draw a volume of cleaning solution from the dialyzer into both pumps; and d) operating both the first and second pumps to expel the volume of cleaning solution from the pumps into the drain.

The second mode preferably comprises: a) opening both the first and second source valves and first and second dialyzer inlet valves, closing both the first and second dialyzer outlet valves and the first and second drain valves and operating the first and second pumps to draw cleaning solution from the cleaning solution source into the first and second pump chambers; b) closing the first and second source valves and the first and second dialyzer outlet valves, opening the first and second dialyzer inlet valves and operating both the first and second pumps to expel the dialysate from the first and second pump chambers into the dialyzer; c) opening the first and second dialyzer outlet valves, closing the first and second dialyzer inlet valves and operating both the first and second pumps to draw a volume of cleaning solution from the dialyzer into the first and second pump chambers; d) opening the first and second drain valves, closing the first and second dialyzer outlet valves and operating both the first and second pumps to expel a volume of cleaning solution from the first and second pump chambers into the drain.

By operating both pumps to deliver cleaning solution to the dialyzer, this provides a greater volume of cleaning solution which can pass across the membrane and into the blood in a single step of the pumping cycle.

The duration of each step of the methods described herein may be in the range of 0.5 seconds to 10 seconds. The duration of each step may be in the range of 1 second to 5 seconds and it is often the case that each method step will be between 1 and 2 seconds in length.

The device of the present invention may be operated using one or more of the second modes discussed and further, it may be the case that the device uses more than one of these second modes during a single treatment session.

BRIEF DESCRIPTION OF THE DRAWINGS

The invention will now be described with reference to the following figures.

FIG. 1 shows a schematic of a dialysis system having a disposable cartridge comprising a fluid path defined by pumps and valves.

FIG. 1a shows a detailed schematic view of the cartridge of FIG. 1.

FIG. 2 shows a schematic view of the operation of a pump of the type defined by the disposable cartridge.

FIG. 3 shows a schematic view of the pump and valve arrangement of the invention.

DESCRIPTION

Referring to FIGS. 1 and 1a, a dialysis system, generally referred to as **10**, is shown. A dialyzer **12** receives blood via an arterial line **14** connected to a patient by a vascular access device (not shown for clarity), for example a hollow needle as typically used for drawing blood from a patient. The blood is pumped from the patient to the dialyzer by a peristaltic pump **16**. The blood passes through the dialyzer in a known manner and is returned to the patient via a venous line **18**. The dialyzer **12** comprises a cylindrical tube closed by opposing ends. A semi-permeable membrane (not shown) is provided within the dialyzer tube and separates the patients blood from a dialysate (cleaning) solution. The membrane extends substantially between the opposing ends of the cylinder. The dialysate solution removes impurities from the patients blood in a known manner.

The dialyzer has an inlet **20** for receiving clean dialysate solution and an outlet **22** for removing spent dialysate solution from the dialyzer **12**. The dialyzer also has an inlet **24** for receiving untreated blood from the peristaltic pump **16** and an outlet **26** for returning processed blood to the patient. The dialyzer **12** is typically provided in a substantially upright orientation, in use, with the patient's blood flowing longitudinally through the dialyzer **12** from the blood inlet **24** to the blood outlet **26**. The dialysate solution inlet **20** and dialysate solution outlet **22** are configured to be orientated substantially orthogonal to the blood inlet **24** and blood outlet **26**, and to provide a counter-flow. Dialysate solution is circulated through the hemodialysis machine at a fluid flow rate in the region of 400 ml/min for approximately four hours.

The dialysis system defines a fluid circuit including a cartridge **30** as will now be described. The cartridge **30** is a consumable component in the hemodialysis machine described.

The cartridge **30** is formed from an acrylic plastic such as SG-10 and has a machine side and a patient side. The cartridge **30** defines pump chambers which are closed by respective diaphragms, formed from, for example, DEHP-free PVC, to define respective pumps. In this embodiment, each diaphragm is part of a single, common sheet of material applied to the machine side of the cartridge **30**. The individual diaphragms are operable by pneumatic pressure applied thereto.

A series of flow paths are formed in the cartridge **30** for carrying dialysate solution constituted from water, bicarbonate solution and acid solution. The flow paths are located between the sheet of material closing the machine side of the cartridge **30** and a further sheet of the same material closing the patient side of the cartridge **30**.

In use, the variation of pressure applied to the flexible diaphragm of each pump chamber is controlled by conventional valving. A pressure source applies either a positive or negative pressure to one side of the diaphragm of each pump

chamber, as required, to pump fluid through the fluid paths in the cartridge **30**, in a circuit defined by a plurality of valves.

The valves of the cartridge **30** are conventional diaphragm valves defined by respective openings in the cartridge **30** and closed by respective flexible diaphragms. Each valve is operable by applying a negative pressure to the diaphragm to open the valve and applying a positive pressure to the diaphragm to close the valve. The diaphragm of each valve is part of the single, common sheet of material applied to the machine side of the cartridge **30**. The valves are opened and closed according to a flow control strategy, as will become apparent.

The machine side of the cartridge **30** abuts a pump driver (not shown) comprising a platen having a plurality of recessed surfaces, each recessed surface substantially corresponding in geometry and volume to a pump chamber defined in the cartridge **30**. Each recessed surface has a fluid port connectable with a source of positive fluid, typically, pressure and, with a source of negative fluid pressure via a valve.

The positive and negative fluid pressure sources include a pressure pump and a vacuum pump respectively. When the valve is operated to allow fluid to flow into a recessed surface from the source of positive fluid pressure, the diaphragm moves into a corresponding pump chamber and any fluid, i.e. dialysate solution, therein is expelled from that pump chamber via the series of flow paths. When the valve is operated to allow fluid to flow out of a recessed surface to the source of negative fluid pressure, the diaphragm is moved away from a pump chamber and into the corresponding recessed surface to permit fluid to be drawn into that pump chamber via the series of flow paths. The surface of the pump chambers and of the platen provide a positive stop for each diaphragm, to prevent overstretching thereof. The positive stop ensures that the volume of fluid drawn into and pumped from the pump chambers is accurately controlled.

The cartridge **30** has two main functions, preparation of dialysate solution and flow balance. Each function is performed by a separate part of the cartridge as illustrated in FIGS. **1** and **2** by the schematic separation of the cartridge into two parts by the line A-A in the figures. The dialysate preparation function is performed by one part of the cartridge, generally referred to at **34** and the flow balance function is performed by the other part of the cartridge, generally referred to at **36**. The cartridge **30** prepares an accurately mixed homogenous dialysate solution and ensures that the flow of clean dialysate supplied to the dialyzer **12** matches (to within clinical tolerances) the volume of spent dialysate drawn from the dialyzer **12**.

The cartridge **30** is provided with a plurality of connections to and from the cartridge **30** as described below.

A first inlet port **38**, from hereon referred to as the water inlet port, defined in the machine side of the cartridge **30** receives purified water from a purified water supply **31** such as a reverse osmosis water supply.

A first outlet port **42**, from hereon referred to as the water outlet port, defined in an edge of the cartridge **30** directs the purified water to a first dialysate solution constituent which, in the illustrated embodiment shown in FIGS. **1** and **1a**, is bicarbonate **46**.

A second inlet port **50**, from hereon referred to as the bicarbonate inlet port, defined in the same edge of the cartridge **30** as the water outlet port **42** receives purified water mixed with the bicarbonate **46**.

A third inlet port **82**, from hereon referred to as the acid inlet port, defined in the opposite edge of the cartridge **30** to

the water outlet port **42** and bicarbonate inlet port **50** receives a second dialysate solution constituent which, in the illustrated embodiment shown in FIGS. **1** and **1a**, is acid **80**.

A second outlet port **104**, from hereon referred to as the clean dialysate solution outlet port, is defined in the same edge of the cartridge as the water outlet port **42** and the bicarbonate inlet port **50**. The clean dialysate outlet port **104** directs clean dialysate solution to the dialyzer **12**.

A fourth inlet port **106**, from hereon referred to as the spent dialysate solution inlet port, is defined in the same edge of the cartridge **30** as the water outlet port **42**, bicarbonate inlet port **50** and clean dialysate outlet port **104**. The spent dialysate solution inlet port **106** receives spent dialysate solution from the dialyzer **12**.

A third outlet port **122**, from hereon referred to as the drain port, is defined in the same edge of the cartridge as the acid inlet port **82**. The drain port **122** directs spent dialysate solution out of the cartridge **30**.

Dialysate Preparation

Dialysate solution is prepared in the cartridge **30** by combining purified water with two dialysate constituents, namely a bicarbonate solution and an acid solution.

Purified water is admitted into the cartridge **30** from a purified water supply **31** via the water inlet port **38**. The purified water passes through a channel **40** via a water inlet valve **41**, when open, and exits the cartridge **30** at the water outlet port **42**. From here, the purified water is carried by a tube **44** through a bicarbonate cartridge **46** in a known manner to generate a purified water and bicarbonate solution. The purified water and bicarbonate solution is carried by a tube **48** and re-admitted into the cartridge **30** via the bicarbonate inlet port **50**.

The temperature of the bicarbonate solution is measured at sensing port **52** and the bicarbonate solution pressure is measured at sensing port **54**. The bicarbonate solution passes a bicarbonate control valve **56**, when open, before entering a bicarbonate solution reservoir **58** having an inlet and an outlet. The bicarbonate control valve **56** is closed when flow therethrough is not required.

A bicarbonate dosing pump chamber **60** having an inlet and an outlet receives the bicarbonate solution from the bicarbonate solution reservoir **58** through a bicarbonate dosing pump inlet valve **62**. The bicarbonate dosing pump chamber **60** is closed by a diaphragm to define a bicarbonate dosing pump which, upon actuation of the diaphragm, pumps the bicarbonate solution from the bicarbonate dosing pump **60** to a first mixing pump chamber **66** (bicarbonate pump chamber). The bicarbonate dosing pump **60** has a bicarbonate dosing pump outlet valve **64** which is closed when the bicarbonate dosing pump inlet valve **62** is open. The bicarbonate dosing pump outlet valve **64** is opened to permit bicarbonate solution to be pumped to the bicarbonate pump chamber **66**. When the bicarbonate dosing pump outlet valve **64** is open, the bicarbonate dosing pump inlet valve **62** is closed to prevent bicarbonate solution from being pumped back into the bicarbonate solution reservoir **58**.

The bicarbonate pump chamber **66** having an inlet and an outlet receives the purified water and bicarbonate solution from the bicarbonate dosing pump **60** via a bicarbonate pump inlet valve **68**. The bicarbonate pump inlet valve **68**, when open, can also admit purified water into the bicarbonate pump chamber **66** from the water inlet port **38**. The bicarbonate pump chamber **66** is closed by a diaphragm to define a pump which, upon actuation of the diaphragm, pumps the bicarbonate solution and purified water therein

13

through a bicarbonate pump outlet valve 70 to a second mixing pump chamber 76 (acid pump).

When the bicarbonate pump inlet valve 68 is open, the bicarbonate pump outlet valve 70 and water outlet valve 41 are closed. When the bicarbonate pump outlet valve 70 is open, the bicarbonate pump inlet valve 68 is closed to prevent the bicarbonate and purified water solution from being pumped back into channel 40.

From the bicarbonate pump outlet valve 70, the bicarbonate and purified water solution enters a sensor channel 72 in which the hemodialysis machine measures the conductivity of the bicarbonate and purified water solution in a known manner. The bicarbonate and purified water solution then enters a temperature sensor 74 before, if the conductivity and temperature of the bicarbonate and purified water solution are within tolerance, entering the acid pump chamber 76.

The acid pump chamber 76 having an inlet and an outlet receives the bicarbonate and purified water solution from the bicarbonate pump 66 via an acid pump inlet valve 78. The acid pump inlet valve 78, when open, can also admit an acid solution into the pump chamber 76. The acid pump chamber 76 is closed by a diaphragm to define a pump which, upon actuation of the diaphragm, pumps the acid solution, bicarbonate solution and purified water therein through an acid pump outlet valve 88 to the first flow balance pump chamber 100. When the acid pump inlet valve 78 is open, the acid pump outlet valve 88 is closed. When the acid pump outlet valve 88 is open, the acid pump inlet valve 78 is closed.

The acid solution is admitted into the cartridge 30 from a pre-determined supply of acid 80 via the acid solution inlet port 82. From the acid solution inlet port the acid solution passes through an acid dosing pump chamber 86 via an acid dosing pump inlet valve 84 and an acid dosing pump outlet valve 87. The acid dosing pump outlet valve 87 is closed when the acid dosing pump inlet valve 84 is open. The acid dosing pump inlet valve 84 is closed when the acid dosing pump outlet valve 87 is open.

The dialysate solution exits the acid pump chamber via the acid pump outlet valve 88 and passes through a first dialysate solution temperature sensor 90 and a first dialysate solution conductivity sensor 92. A second dialysate solution temperature sensor 94 and a second dialysate solution conductivity sensor 96 are provided to corroborate the data provided by the first dialysate solution temperature sensor 90 and the first dialysate solution conductivity sensor 92. Providing the data measured by sensors 90, 92, 94 and 96 is within tolerance, the dialysate solution is admitted into a first flow balance pump chamber 100

Flow Balance

The flow balance function of the cartridge 30 provides first and second flow balance pump chambers 100, 108, each having two inlets and two outlets to define two independent flow paths therethrough. The first and second flow balance pump chambers 100, 108 are of approximately equal volume. Either the first or second flow balance pump chamber 100, 108 pumps dialysate solution to a dialyzer 12 and the other of the first or second flow balance pump chambers 100, 108 pumps dialysate solution from the dialyzer 12 to the drain port 122. After every approximately 20 strokes of the first and second flow balance pumps 100, 108, their function is reversed.

From this point onwards, dialysate solution will be referred to as either clean dialysate solution or spent dialysate solution. Clean dialysate solution is intended to mean dialysate solution that is either new dialysate solution or clean dialysate solution that has been treated to remove

14

waste product therefrom. Spent dialysate solution is intended to mean dialysate solution that has passed through the dialyzer 12 to remove waste fluids from a patient's blood into the dialysate solution.

Each of the first and second flow balance pump chambers 100, 108 are closed by a diaphragm to define respective pumps. The diaphragm is actuated away from a pump chamber by a negative pressure source to draw a volumetrically measured quantity of dialysate solution into the pump chamber. The diaphragm is actuated toward the pump chamber to pump the fluid therein out of an outlet.

The first flow balance pump chamber 100 has a clean dialysate solution inlet valve 98 for receiving clean dialysate solution from the acid pump 76 and a clean dialysate solution outlet valve 102 for pumping clean dialysate solution to the dialyzer 12. The first flow balance pump chamber 100 also has a spent dialysate solution inlet valve 118 for receiving spent dialysate from the dialyzer 12 and a spent dialysate solution outlet valve 120 for pumping the spent dialysate to drain via drain outlet port 122.

At any one time, only one of valves 98, 102, 118 or 120 will be open and the other three valves will be closed. The flow balance function, as described above, requires alternating the function of each flow balance pump approximately every 20 cycles. Therefore, when the first flow balance pump 100 is pumping clean dialysate solution to the dialyzer 12, only valves 98 and 102 are in use and when the first flow balance pump 100 is pumping spent dialysate solution from the dialyzer 12 to drain, only valves 118 and 120 will be in use.

The clean dialysate solution is pumped out of the first flow balance pump chamber 100 through the first flow balance pump clean dialysate solution outlet valve 102, upon closure of the first flow balance pump clean dialysate inlet valve 98, to the dialyzer 12 via the dialyzer outlet port 104.

Spent dialysate solution returns to the cartridge 30 from the dialyzer 12 via the dialyzer inlet port 106. The second flow balance pump chamber 108 has a spent dialysate solution inlet valve 110 for receiving spent dialysate solution from the dialyzer 12 and a spent dialysate solution outlet valve 112 for pumping the spent dialysate solution to drain via drain outlet port 122. The second flow balance pump 108 also has a clean dialysate solution inlet valve 114 for receiving clean dialysate solution from the acid pump chamber 76 and a clean dialysate solution outlet valve 116 for pumping clean dialysate solution to the dialyzer 12.

At any one time, only one of valves 110, 112, 114, 116 will be open and the other three valves will be closed. When the second flow balance pump 108 is pumping clean dialysate solution to the dialyzer 12, only valves 114 and 116 will be in use and when the second flow balance pump 108 is pumping spent dialysate solution from the dialyzer 12 to drain, only valves 114 and 116 will be in use.

In the illustrated example, the operation of the first and second flow balance pumps 100, 108 can be switched so that the first flow balance pump 100 is used to draw spent dialysate solution from the dialyzer 12 and the second flow balance pump 108 is used to pump clean dialysate solution into the dialyzer 12 as described below.

The clean dialysate solution is drawn into the second flow balance pump chamber 108 from the acid pump 76 via the second flow balance pump clean dialysate solution inlet valve 114 upon actuation of the diaphragm. The clean dialysate solution is then pumped from the second flow balance pump chamber 108 via the second flow balance

pump clean dialysate solution outlet valve **116**, upon closure of the clean dialysate solution inlet valve **114**, to the dialyzer **12**.

Spent dialysate solution from the dialyzer **12** is drawn into the first flow balance pump **100** via the second flow balance pump spent dialysate solution inlet valve **118**. The spent dialysate solution is then pumped out of the first flow balance pump chamber **100** via the second flow balance pump spent dialysate solution outlet valve **120**, upon closure of the spent dialysate solution inlet valve **118**, to drain via drain outlet port **122**.

The volume of fluid that is returned from the dialyzer **12** is greater than the volume of fluid that is pumped to the dialyzer via the first or second flow balance pump **100**, **108**. The first and second flow balance pumps have fixed volumes meaning that the excess fluid volume cannot be accommodated in the first or second flow balance pump. An ultrafiltration pump **200** is provided between the first and second flow balance pumps **100**, **108** and has an inlet valve **210** and an outlet valve **212**. The ultrafiltration pump **200** comprises a concave recess in the cartridge closed by a flexible diaphragm, the concave recess and the flexible diaphragm defining an ultrafiltration pump chamber.

In use, the inlet valve **210** of the ultrafiltration pump **200** is opened to allow the ultrafiltration pump to draw in a pre-determined volume of spent dialysate solution. When the inlet valve **210** of the ultrafiltration pump is open, the outlet valve **212** of the ultrafiltration pump **200** is closed. When the ultrafiltration pump **200** has received a volume of spent dialysate solution, the outlet valve **212** is opened and the spent dialysate solution in the ultrafiltration pump chamber is pumped through the outlet valve **212** to drain via the drain outlet port **122**. When the outlet valve **212** of the ultrafiltration pump **200** is open, the inlet valve **210** of the ultrafiltration pump **200** is closed.

The purpose of the ultrafiltration pump is to remove excess fluid generated by the patient. By separating the ultrafiltration pump operation from the flow balance pumps and by employing a pump arrangement described herein, fluid can be removed from the dialyzer at appropriate intervals between the stages of the operation of the flow balance pumps, without requiring modification to the flow balance pump operation. Usually, the ultrafiltration pump will remove fluid from the dialyzer during a pump swapping operation of the flow balance pumps and this may be done in the range of once every 10 to once every 30 flow balance pump cycles. Typically, fluid is removed from the dialyzer by the ultrafiltration pump approximately once every 20 pump cycles.

FIG. 2 shows a representative view of a flow balance pump **100** according to the present invention. The flow balance pump chamber **194** is provided on the cartridge and is closed by a diaphragm **196** which, at rest, sits across the pump chamber **194**. The pump chamber receives either clean or spent dialysate solution via a dialysate solution inlet port **210** and pumps dialysate solution from the pump chamber via a dialysate solution outlet port **212**.

The cartridge **30** is removably mounted into a hemodialysis machine which has a flow balance pump cavity **198** substantially corresponding in dimension and shape to the pump chamber **194**. Upon supply of positive or negative pressure via a pump cavity pressure inlet port **214**, the diaphragm is actuated into either the pump chamber **194** or pump cavity **198** to either draw fluid into the pump chamber **194** or pump fluid from the pump chamber **194**.

Cartridge Cleaning

After each use, the hemodialysis machine requires sanitising to prevent contamination of a patient's bloodstream during subsequent dialysis sittings. The removable cartridge **30**, as described above, is usually disposed of after each sitting. In one embodiment of the invention, the cartridge **30** is sanitised to allow re-use in subsequent dialysis sittings.

Operation of the Device

FIG. 3 shows a schematic representation of the pump and valve arrangement **201** of the invention. In this case, the pump and valve arrangement **201** is provided by the combination of a membrane pump cartridge (or part cartridge) and a vacuum pump array with platen. The membrane pump cartridge is similar in layout to the flow balance pump arrangement described above.

The membrane pump cartridge comprises first and second source valves **205**, **206**, first and second pumps **207**, **216** and first and second pump chambers **208**, **218**, first and second dialyzer inlet valves **209**, **217** and first and second dialyzer outlet valves **213**, **215**.

The vacuum pump array and platen comprises a platen having a pattern of circular depressions which correspond in position and size to the valves and pumps on the pump cartridge. In the figure, these are numbered **100** higher than the membrane pump features.

Each depression has an aperture at the base thereof which is in fluid communication with an associated vacuum pump. Each vacuum pump, shown in broken lines as they sit on the rear face of the platen, is numbered **100** higher than the respective associated platen feature.

All of the vacuum pumps are connected to a control system **500**. The control system **500** is a microprocessor which operates the vacuum pumps **405-419** in a manner so as to effect either hemodiafiltration or hemodialysis as described below. The connection to the pumps may be wired or wireless. Wireless connection options include IR, Bluetooth or WIFI, amongst others.

The dialysate is produced elsewhere on the cartridge by mixing acid and bicarbonate compounds with a set volume of de-ionised, water provided by a reverse osmosis machine which has been sterilised as is described above. This forms the source of dialysate **327** used by the pump and valve arrangement **201**.

By selectively operating the vacuum pumps, the control system controls the opening and closure of the valves as well as actuation of the first and second pumps. The microprocessor control system is programmable to operate the valves in a variety of different configurations. Based on the programming of the controller, the controller will communicate with each of the valves or means for operating the valves, so that each valve may be opened and closed independently based on the programming entered into the controller by the user, skilled operator or programme instructions.

First Mode of Operation—Hemodialysis

The pumping cycle of the first mode of operation of the arrangement **201** begins with closure of the first and second dialyzer inlet valves **209**, **217** and the first and second dialyzer outlet valves **213**, **215**. The first source valve **205** and the first drain valve **219** are opened, the second source valve **206** and second drain valve **211** are closed. The first pump **207** is then operated to draw dialysate **327** from the dialysate source **203** into the first pump chamber **208** of the first pump **207** and the second pump **216** is operated to expel dialysate **327** within the second pump chamber **218** of the second pump **216** into the drain **221**. Accordingly, the dialysate **327** in the dialysate source **203** is drawn into the

17

first pump chamber **208** by the negative pressure created as the membrane of the first pump chamber **208** is drawn away from the pump chamber by vacuum means in the dialysis machine (not shown). The dialysate **327** in the second pump chamber **218** is subjected to a positive pressure as the membrane in the second pump **216** is forced into the second pump chamber **218** thus driving the dialysate out through the open first drain valve **219** to be discarded.

In the next stage of the pump cycle, the first dialyzer inlet valve **209** and the first dialyzer outlet valve **215** are opened and the first source valve **205** and the first drain valve **219** are closed. The first pump **207** is then actuated to expel the dialysate **327** from within the first pump chamber **208** into the dialyzer (not shown) and the second pump **216** is actuated to pull spent dialysate **327** from the dialyzer (not shown) into the second pump chamber **218**. In this step, the dialysate **327** in the first pump chamber **208** has a positive pressure applied to it as the membrane is force down into the first pump chamber **208** thereby forcing the dialysate **327** through the dialysis circuit and into the dialyzer. In the dialyzer, dialysate **327** is passed in a typically counterflow arrangement to the blood of the patient and waste products diffuse across the dialyzer membrane into the dialysate **327** via diffusion. The movement of the dialysate **327** through the dialyzer and into the second pump chamber is assisted by a negative pressure generated by the membrane of the second pump chamber which is retracted by the vacuum means on the dialysis machine, operated by the device's controller. These two stages are repeated and then, in the third stage of the pump cycle, the first dialyzer inlet valve **209** and first dialyzer outlet valve **215** are closed, the first drain valve **219** is opened and second pump **216** actuated to expel the spent dialysate **327** from the second pump chamber **218** into the drain **221**. Accordingly, after the completion of this step, both pump chambers **208**, **218** are empty.

In the fourth step of the cycle, the first drain valve **219** is closed and the second source valve **206** is opened in order to allow the second pump **216** to draw dialysate from the source **203** into the second pump chamber **218**. In the fifth step, with the second pump chamber **218** now filled, the second dialyzer inlet valve **217** the second dialyzer outlet valves **213** are opened and the second source valve is closed. The second pump **216** is actuated to expel the dialysate in the second pump chamber **218** into the dialyzer (not shown) and the first pump **207** is actuated to draw dialysate from the dialyzer into the first pump chamber **208**. This allows the same operation as was carried out in the first and second steps to proceed but with the roles of the pumps **207**, **216** swapped around. Thus any small discrepancies between the volumes of the two pump chambers **208**, **218** are cancelled out.

The fourth and fifth steps are repeated and finally, the second dialyzer outlet valve **213** and second dialyzer inlet valve **217** are closed, the second drain valve **211** and second source valves are opened and the first pump **207** is operated to expel the dialysate from the first pump chamber **208** into the drain **221**.

Second Mode of Operation—Hemodiafiltration (Twin Pumping)

The pumping cycle of the second mode of operation of the arrangement **201** begins with opening both the first and second source valves **205**, **206** and first and second dialyzer inlet valves **217**, **217** together with closing both the first and second dialyzer outlet valves **213**, **215** and the first and second drain valves **205**, **206**. The first and second pumps

18

207, **216** are both actuated to draw dialysate from the source **203** into the first and second pump chambers **208**, **218** respectively. Accordingly, dialysate **327** drawn into both chambers **208**, **218** from the dialysate source **203** due to the negative pressure created by the movement of the membrane in the pumps **207**, **216**.

In the second step, the first and second source valves **205**, **206** and the first and second dialyzer outlet valves **213**, **215** are closed, the first and second dialyzer inlet valves **209**, **217** are opened and both the first and second pumps **207**, **216** are actuated to expel the dialysate from the first and second pump chambers **208**, **218** respectively into the dialyzer. Thus, when the pumps **207**, **216** are activated a positive pressure is generated which forces dialysate **327** into the dialyzer. As the dialyzer outlet valves **213**, **215** are closed, the dialysate **327** has nowhere else to go and so at least some of the dialysate **327** passes across the semipermeable membrane of the dialyzer and into the blood side of the dialyzer. This allows the dialysate **327** to mix with the blood and dissolve many of the harmful waste products built up in the blood.

In the third step, the first and second dialyzer outlet valves **213**, **215** are opened, the first and second dialyzer inlet valves **209**, **217** are closed and both the first and second pumps **207**, **216** are actuated to draw spent dialysate from the dialyzer into the first and second pump chambers **208**, **218** respectively. Because the dialysate source valves **205**, **206** are closed, the negative pressure generated by the pumps **207**, **216** is felt by the dialyzer and this draws the dialysate **327**, along with dissolved and associated waste components, back across the semipermeable dialyzer membrane and fills the pump chambers **208**, **218**. As such, there is substantially no net transfer of dialysate to the patient's blood. The duration of the steps in each of the methods of the invention is typically about 1 second.

Finally, the first and second drain valves **211**, **219** are opened, the first and second dialyzer outlet valves **215**, **213** are closed and both the first and second pumps **207**, **216** are actuated to expel spent dialysate from the first and second pump chambers **208**, **218** respectively into the drain **221**.

Second Mode of Operation—Hemodiafiltration (Split Pumping)

Alternatively the pumping cycle of the second mode of operation of the arrangement **201** may begin with closure of the first and second dialyzer inlet valves **209**, **217** opening the first dialyzer outlet valve **215**, closing the second dialyzer outlet valve **213**, opening the first source valve **205**, closing the second source valve **206**, closing the first and second drain valves **219**, **211**. The first pump **207** is then actuated to draw dialysate **327** from the source **203** into the first pump chamber **208** and the second pump **216** is actuated to draw dialysate **327** from the dialyzer into the second pump chamber **218**. Accordingly, dialysate **327** is drawn into both pump chambers **208**, **218** by negative pressure created in both pumps **207**, **216**. The dialysate **327** drawn from the dialyzer is pulled from the patient's blood, across the semipermeable membrane of the dialyzer and into the second pump chamber **218**. As the first dialyzer inlet valve **209** is closed, the dialysate **327** does not flow backwards along the dialysate **327** circuit into the first pump chamber **208**. The first pump chamber **208** is instead filled by drawing dialysate **327** from the dialysate source **203**.

In the second step, the first dialyzer inlet valve **209** and the first drain valve **219** are opened, the first dialyzer outlet valve **215** and the first source valve **205** are closed and the

19

first pump 207 is actuated to expel dialysate from the first pump chamber 208 into the dialyzer and the second pump 216 is actuated to expel dialysate from second pump chamber 218 into the drain 221. Thus, dialysate 327 in the first pump chamber 208 is forced under positive pressure into the dialyzer but as the dialyzer outlet valves 215, 213 are closed, the dialysate has nowhere else to go except across the semipermeable membrane of the dialyzer and into the blood side of the dialyzer.

These two steps are repeated and then, in the third step, the first dialyzer inlet valve 209 and the first drain valve are closed 219, the second dialyzer outlet valve 213 and second source valve 206 are opened. The second pump 216 is actuated to draw dialysate from the source into the second pump chamber 218 and the first pump 207 is actuated to draw dialysate from the dialyzer (not shown) into the first pump chamber 208.

Finally, the second dialyzer inlet valve 217 and the second drain valve 211 are opened, the first and second dialyzer outlet valves 215, 213 and the first source valve 205 are closed and the first pump 207 is actuated to expel dialysate from the first pump chamber 208 into the drain 221 and operating the second pump 216 to expel dialysate from the second pump chamber 218 into the dialyzer (not shown). The operation of the third and fourth step is the same as the first and second except that the roles of the first and second pumps have been swapped over.

Second Mode of Operation—Hemodiafiltration (Split Pumping with Delay)

Alternatively, the second mode of operation of the arrangement 201 may begin with opening the first source valve 205 and the first drain valve 219, closing the first dialyzer outlet valve 215 and operating the second pump 216 to expel dialysate from the second pump chamber 218 into the drain 221 and operating the first pump 207 to draw dialysate into the first pump chamber 208 from the dialysate source 203.

In the second step, the first dialyzer inlet valve 209 is opened and the first dialyzer outlet valve 215, the first source valve 205 and the first drain valve 219 are closed. The first pump 207 is then actuated to expel dialysate from the first pump chamber 208 into the dialyzer and the second pump 216 is left idle. Thus, dialysate 327 in the first pump chamber 208 is forced under positive pressure into the dialyzer but as the dialyzer outlet valves 215, 213 are closed, the dialysate has nowhere else to go and so passes across the semipermeable membrane of the dialyzer and into the blood side of the dialyzer.

In the third step, the first dialyzer inlet valve 209 is closed, the first dialyzer outlet valve 215 is opened, the first pump 207 is left idle and the second pump 216 is actuated to draw dialysate from the dialyzer into the second pump chamber. The dialysate 327 drawn from the dialyzer is pulled from the patient's blood, across the semipermeable membrane of the dialyzer and into the second pump chamber 218.

The first, second and third steps are then repeated. In the fourth step. The second pump is operated to expel the dialysate 327 in the second pump chamber into the drain. Accordingly, after the fourth step, both pump chambers are empty.

In the fifth step, the second source valve 206 is opened and the first drain valve 211 and first dialysate outlet valve 213 are closed and the second pump 216 is operated to draw dialysate 327 from the dialysate source 203 into the second pump chamber 218. The second source valve 206 is the

20

closed, the second dialyzer inlet valve 217 is opened and the pump is activated to expel the dialysate 327 in the second pump chamber 218 into the dialyzer.

In a sixth step, the second dialyzer inlet valve 217 is closed and the second dialyzer outlet valve 215 is opened and the first pump is operated to draw dialysate 327 from the dialyzer into the first pump chamber 208.

Finally, the second drain valve is opened and the first dialyzer inlet valve and second dialyzer outlet valve is closed and the dialysate is expelled from the first pump chamber into the drain.

The fifth, sixth and seventh method steps are then repeated thereby completing the pumping cycle.

Although the control system 500 has been described in the specific embodiment as a microprocessor, the control system 500 may instead comprise an electrical switching arrangement or a mechanical control arrangement. In the case of a mechanical control arrangement, rather than individual vacuum pumps for each platen cavity, it is envisaged that a single vacuum pump would apply a negative pressure to the platen and a mechanical camming or gearing arrangement would actuate valves on the platen to control the application of the negative/positive pressure selectively according to the required operating mode.

The invention claimed is:

1. A blood treatment device comprising:

a dialyzer;

a flow balance pump and valve arrangement, comprising:

a first pump operable to deliver a predetermined volume of cleaning solution from a cleaning solution source to the dialyzer or to remove the predetermined volume of cleaning solution from the dialyzer to a drain;

a second pump operable to deliver the predetermined volume of cleaning solution from the cleaning solution source to the dialyzer or to remove the predetermined volume of cleaning solution from the dialyzer to the drain;

a first dialyzer inlet valve arranged between the first pump and an inlet of the dialyzer;

a second dialyzer inlet valve arranged between the second pump and the inlet of the dialyzer;

a first dialyzer outlet valve arranged between an outlet of the dialyzer and the second pump;

a second dialyzer outlet valve arranged between the outlet of the dialyzer and the first pump;

a first cleaning solution source valve arranged between the cleaning solution source and the first pump;

a second cleaning solution source valve arranged between the cleaning solution source and the second pump;

a first drain valve arranged between the second pump and the drain;

a second drain valve arranged between the first pump and the drain; and

each of the valves and the pumps of the flow balance pump and valve arrangement being independently operable; and

a control system configured to operate the valves and pumps of the flow balance pump and valve arrangement in at least one first mode permitting hemodialysis and at least one second mode permitting hemodiafiltration;

wherein hemodialysis occurs because waste product from a patient's blood transfers to the cleaning solution via

21

diffusion across a semi-permeable membrane in the dialyzer, but the cleaning solution substantially does not cross the membrane;

wherein hemodiafiltration occurs because the waste product from the patient's blood transfers to the cleaning solution when the cleaning solution is forced across the membrane into the patient's blood and then pulled back across the membrane; and

wherein the at least one second mode includes operating the first pump and the second pump in phase to generate a positive pressure in the dialyzer, or operating the first pump and the second pump out of phase to generate a positive pressure in the dialyzer.

2. A device according to claim 1, wherein the control system is configured, in use, to alternate the operation of the valves and pumps between the at least one first mode and the at least one second mode.

3. A device according to claim 1, wherein the control system is configured to alternate the pump responsible for delivering cleaning solution to the dialyzer and the pump responsible for removing spent cleaning solution from the dialyzer after a given number of pumping cycles.

4. A device according to claim 3, wherein the number of pumping cycles is two or more pumping cycles.

5. A device according to claim 1, wherein the pumps are positive displacement pumps.

6. A device according to claim 5, wherein the pumps are membrane pumps.

7. A device according to claim 1, wherein the flow balance pump and valve arrangement is formed on a disposable cartridge.

8. A device according to claim 7, wherein the pumps and valves on the disposable cartridge are actuated by selective application of a negative or a positive air pressure thereto.

9. A device according to claim 8, wherein the selective application of the negative or the positive air pressure is effected by a pneumatic pump.

10. A device according to claim 9, wherein each pump or valve has an associated pneumatic pump on a machine which receives the cartridge.

11. A device according to claim 10, wherein the control system controls the operation of the respective pneumatic pumps.

12. A device according to claim 11, wherein the control system is a microprocessor which controls the pneumatic pumps electronically.

13. A device according to claim 12, wherein the control is effected wirelessly.

14. A method of operating the device according to claim 1,

wherein the valves and pumps of the flow balance pump and valve arrangement are operated by the control system in the at least one first mode permitting hemodialysis and the at least one second mode permitting hemodiafiltration.

15. A method according to claim 14, wherein the valves and pumps are operated to alternate between the at least one first mode permitting hemodialysis and the at least one second mode permitting hemodiafiltration.

16. A method according to claim 14, wherein the valves and pumps are operated in the at least one second mode permitting hemodiafiltration by operating the first and second pumps in phase to generate a positive pressure in the dialyzer.

22

17. A method according to claim 14, wherein the at least one first mode comprises the steps of:

a) operating the first pump to draw the predetermined volume of cleaning solution from the cleaning solution source into the first pump and operating the second pump to expel the predetermined volume of spent cleaning solution from the second pump into the drain; and

b) operating the first pump to expel the predetermined volume of cleaning solution from the first pump into the dialyzer and operating the second pump to draw the predetermined volume of spent cleaning solution from the dialyzer into the second pump.

18. A method according to claim 14, wherein the first mode comprises the steps of:

a) closing the first dialyzer inlet valve, closing the first dialyzer outlet valve, operating the first pump to draw the predetermined volume of cleaning solution from the cleaning solution source into the first pump and operating the second pump to expel the predetermined volume of cleaning solution from the second pump into the drain; and

b) opening the first dialyzer inlet valve, opening the first dialyzer outlet valve, operating the first pump to expel the predetermined volume of cleaning solution from the first pump into the dialyzer and operating the second pump to draw the predetermined volume of cleaning solution from the dialyzer into the second pump.

19. A method according to claim 14, wherein the first mode comprises the steps of:

a) closing the first dialyzer inlet valve, closing the first dialyzer outlet valve, opening the first clean solution source valve, opening the first drain valve, operating the first pump to draw the predetermined volume of cleaning solution from the cleaning solution source into the first pump and operating the second pump to expel the predetermined volume of cleaning solution from the second pump into the drain; and

b) opening the first dialyzer inlet valve, opening the first dialyzer outlet valve, closing the first clean solution source valve, closing the first drain valve, operating the first pump to expel the predetermined volume of cleaning solution from the first pump into the dialyzer and operating the second pump to draw the predetermined volume of cleaning solution from the dialyzer into the second pump.

20. A method according to claim 14, wherein the first mode comprises the steps of:

a) closing the first and second dialyzer inlet valves, closing the first and second dialyzer outlet valves, opening the first cleaning solution source valve, opening the first drain valve, closing the second cleaning solution source valve, closing the second drain valve, operating the first pump to draw the predetermined volume of cleaning solution from the cleaning solution source into the first pump and operating the second pump to expel the predetermined volume of cleaning solution from the second pump into the drain;

b) opening the first dialyzer inlet valve, opening the first dialyzer outlet valve, closing the first clean solution source valve, closing the first drain valve, operating the first pump to expel the predetermined volume of cleaning solution from the first pump into the dialyzer and operating the second pump to draw the predetermined volume of cleaning solution from the dialyzer into the second pump;

23

- c) closing the first dialyzer inlet valve, closing the first dialyzer outlet valve, opening the first drain valve, and operating the second pump to expel the predetermined volume of cleaning solution from the second pump into the drain;
- d) closing the first drain valve, opening the second cleaning solution source valve, and operating the second pump to draw the predetermined volume of cleaning solution from the clean solution source;
- e) opening the second dialyzer inlet valve, opening the second dialyzer outlet valve, closing the second cleaning solution source valve, operating the second pump to expel the predetermined volume of cleaning solution from the second pump into the dialyzer and operating the first pump to draw the predetermined volume of cleaning solution from the dialyzer into the first pump; and
- f) closing the second dialyzer outlet valve, opening the second drain valve, closing the second dialyzer inlet valve, opening the second cleaning solution source valve, operating the second pump to draw the predetermined volume of cleaning solution from the cleaning solution source and operating the first pump to expel the predetermined volume of cleaning solution from the first pump into the drain.

21. A method according to claim 20, wherein the first mode further comprises repeating steps a) and b) one or more times before performing step c).

22. A method according to claim 20, wherein the first mode further comprises repeating steps e) and f) one or more times.

23. A method according to claim 14, wherein the at least one second mode comprises the steps of:

- a) operating the first pump to draw the cleaning solution from the cleaning solution source into the first pump and operating the second pump to draw the predetermined volume of cleaning solution from the dialyzer into the second pump; and
- b) operating the first pump to expel the predetermined volume of cleaning solution from the first pump into the dialyzer and operating the second pump to expel the predetermined volume of cleaning solution from the second pump into the drain.

24. A method according to claim 14, wherein the second mode comprises the steps of:

- a) closing the first dialyzer inlet valve, opening the first dialyzer outlet valve, operating the first pump to draw the predetermined volume of cleaning solution from the cleaning solution source into the first pump and operating the second pump to draw the predetermined volume of cleaning solution from the dialyzer into the second pump; and
- b) opening the first dialyzer inlet valve, closing the first dialyzer outlet valve, operating the first pump to expel the predetermined volume of cleaning solution from the first pump into the dialyzer and operating the second pump to expel the predetermined volume of cleaning solution from the second pump into the drain.

25. A method according to claim 14, wherein the second mode comprises the steps of:

- a) closing the first dialyzer inlet valve, opening the first dialyzer outlet valve, opening the first cleaning solution source valve, closing the first drain valve, operating the first pump to draw the predetermined volume of cleaning solution from the cleaning solution source into the first pump and operating the second pump to draw the

24

predetermined volume of cleaning solution from the dialyzer into the second pump; and

- b) opening the first dialyzer inlet valve, closing the first dialyzer outlet valve, closing the first cleaning solution source valve, opening the first drain valve, operating the first pump to expel the predetermined volume of cleaning solution from the first pump into the dialyzer and operating the second pump to expel the predetermined volume of cleaning solution from the second pump into the drain.

26. A method according to claim 14, wherein the second mode comprises the steps of:

- a) closing the first and second dialyzer inlet valves, opening the first dialyzer outlet valve, closing the second dialyzer outlet valve, opening the first cleaning solution source valve, closing the second cleaning solution source valve, closing the first and second drain valves, operating the first pump to draw the predetermined volume of cleaning solution from the cleaning solution source into the first pump and operating the second pump to draw the predetermined volume of cleaning solution from the dialyzer into the second pump;
- b) opening the first dialyzer inlet valve, closing the first dialyzer outlet valve, closing the first cleaning solution source valve, opening the first drain valve, operating the first pump to expel the predetermined volume of cleaning solution from the first pump into the dialyzer and operating the second pump to expel the predetermined volume of cleaning solution from the second pump into the drain;
- c) closing the first dialyzer inlet valve, opening the second dialyzer outlet valve, opening the second cleaning solution source valve, closing the first drain valve, operating the second pump to draw the predetermined volume of cleaning solution from the cleaning solution source into the second pump and operating the first pump to draw the predetermined volume of cleaning solution from the dialyzer into the first pump; and
- d) opening the second dialyzer inlet valve, closing the first and second dialyzer outlet valves, closing the first cleaning solution source valve, opening the second drain valve, operating the first pump to expel the predetermined volume of cleaning solution from the first pump into the drain and operating the second pump to expel the predetermined volume of cleaning solution from the second pump into the dialyzer.

27. A method according to claim 26, further comprising repeating steps a) and b) one or more times before performing step c).

28. A method according to claim 26, further comprising a step after step d) of repeating steps c) and d) one or more times.

29. A method according to claim 14, wherein the second mode comprises the steps of:

- a) operating the first pump to draw the predetermined volume of cleaning solution from the cleaning solution source into the first pump and operating the second pump to expel the predetermined volume of cleaning solution from the second pump into the drain;
- b) operating the first pump to expel the predetermined volume of cleaning solution from the first pump into the dialyzer; and
- c) operating the second pump to draw the predetermined volume of cleaning solution from the dialyzer into the second pump.

25

30. A method according to claim 14, wherein the second mode comprises the steps of:

- a) opening the first cleaning solution source valve, operating the first pump to draw the predetermined volume of cleaning solution from the cleaning solution source into the first pump and operating the second pump to expel the predetermined volume of cleaning solution from the second pump into the drain;
- b) opening the first dialyzer inlet valve, operating the first pump to expel the predetermined volume of cleaning solution from the first pump into the dialyzer; and
- c) closing the first dialyzer inlet valve, opening the first dialyzer outlet valve, operating the second pump to draw the predetermined volume of cleaning solution from the dialyzer into the second pump.

31. A method according to claim 14, wherein the second mode comprises the steps of:

- a) closing the first dialyzer outlet valve, opening the first cleaning solution source valve, opening the first drain valve, operating the first pump to draw the predetermined volume of cleaning solution from the cleaning solution source into the first pump and operating the second pump to expel the predetermined volume of cleaning solution from the second pump into the drain;
- b) opening the first dialyzer inlet valve, closing the first cleaning solution source valve, and operating the first pump to expel the predetermined volume of cleaning solution from the first pump into the dialyzer; and
- c) closing the first dialyzer inlet valve, opening the first dialyzer outlet valve, closing the first drain valve, and operating the second pump to draw the predetermined volume of cleaning solution from the dialyzer into the second pump.

32. A method according to claim 14, wherein the second mode comprises the steps of:

- a) closing the first dialyzer outlet valve, opening the first cleaning solution source valve, opening the first drain valve, operating the first pump to draw the predetermined volume of cleaning solution from the cleaning solution source into the first pump and operating the second pump to expel the predetermined volume of cleaning solution from the second pump into the drain;
- b) opening the first dialyzer inlet valve, closing the first cleaning solution source valve, and operating the first pump to expel the predetermined volume of cleaning solution from the first pump into the dialyzer;
- c) closing the first dialyzer inlet valve, opening the first dialyzer outlet valve, closing the first drain valve, and operating the second pump to draw the predetermined volume of cleaning solution from the dialyzer into the second pump;
- d) opening the first drain valve, closing the first dialyzer outlet valve, and operating the second pump to expel the cleaning solution from the second pump into the drain;
- e) closing the first drain valve, opening the second source valve, closing the second dialyzer inlet valve and operating the second pump to draw a predetermined volume cleaning solution from the cleaning solution source into the second pump;
- f) closing the second source valve, opening the second dialyzer inlet valve and operating the second pump to expel the predetermined volume of cleaning solution from the second pump into the dialyzer;
- g) closing the second dialyzer inlet, opening the second dialyzer outlet, closing the second drain valve and

26

operating the first pump to draw the predetermined volume of cleaning solution into the first pump; and

- h) opening the second drain valve, closing the second dialyzer outlet valve, opening the second source valve and operating the first pump to expel the predetermined volume of cleaning solution from the first pump into the drain and operating the second pump to draw the predetermined volume of cleaning solution from the cleaning solution source into the second pump.

33. A method according to claim 32, further comprising repeating steps a) to c) one or more times before performing step d).

34. A method according to claim 32, further comprising a step after step h) of repeating steps f) to h) one or more times.

35. A method according to claim 14, wherein the second mode comprises the steps of:

- a) operating both the first and second pumps to draw the predetermined volume of cleaning solution from the cleaning solution source into each of the first and second pumps;
- b) operating both the first and second pumps to expel the predetermined volume of cleaning solution from each of the first and second pumps into the dialyzer and across the membrane of the dialyzer;
- c) operating the first and second pumps to draw the predetermined volume of cleaning solution from the dialyzer into each of the first and second pumps; and
- d) operating both the first and second pumps to expel the predetermined volume of cleaning solution from each of the first and second pumps into the drain.

36. A method according to claim 14, wherein the second mode comprises:

- a) opening the first and second cleaning solution source valves and the first and second dialyzer inlet valves, closing the first and second dialyzer outlet valves and the first and second drain valves and operating the first and second pumps to draw the predetermined volume of cleaning solution from the cleaning solution source into each of the first and second pumps;
- b) closing the first and second source valves and the first and second dialyzer outlet valves, opening the first and second dialyzer inlet valves and operating both the first and second pumps to expel the predetermined volume of cleaning solution from each of the first and second pumps into the dialyzer;
- c) opening the first and second dialyzer outlet valves, closing the first and second dialyzer inlet valves and operating both the first and second pumps to draw the predetermined volume of cleaning solution from the dialyzer into each of the first and second pumps; and
- d) opening the first and second drain valves, closing the first and second dialyzer outlet valves and operating both the first and second pumps to expel the predetermined volume of cleaning solution from each of the first and second pumps into the drain.

37. The method according to claim 14, wherein the valves and pumps are operated in the at least one second mode permitting hemodiafiltration by operating the first and second pumps out of phase to generate a positive pressure in the dialyzer.

38. *A blood treatment device comprising:*

- a) a dialyzer;
- a first pump configured to deliver a cleaning solution to, and remove the cleaning solution from, the dialyzer;

27

a second pump configured to deliver the cleaning solution to, and remove the cleaning solution from, the dialyzer; and

a control system configured to operate one or more valves, the first pump, and the second pump in at least one first mode permitting hemodialysis and at least one second mode permitting hemodiafiltration, wherein the at least one second mode permitting hemodiafiltration includes transferring waste product from blood of a patient to the cleaning solution as the cleaning solution is forced across a semi-permeable membrane of the dialyzer and into the blood of the patient and then pulled back across the semi-permeable membrane, and the control system operates the first pump and the second pump out of phase with one another or in phase with one another such that a positive pressure is generated in the dialyzer in the at least one second mode permitting hemodiafiltration.

39. The blood treatment device of claim 38, wherein the control system operates the one or more valves, the first pump, and the second pump to alternate between the at least one first mode permitting hemodialysis and the at least one second mode permitting hemodiafiltration.

40. The blood treatment device of claim 38, further comprising the one or more valves.

28

41. The blood treatment device of claim 38, wherein the one or more valves comprise at least one of a first dialyzer inlet valve, a second dialyzer inlet valve, a first dialyzer outlet valve, a second dialyzer outlet valve, a first cleaning solution source valve, a second cleaning solution source valve, a first drain valve, and a second drain valve.

42. The blood treatment device of claim 38, wherein the one or more valves comprise at least two of a first dialyzer inlet valve, a second dialyzer inlet valve, a first dialyzer outlet valve, a second dialyzer outlet valve, a first cleaning solution source valve, a second cleaning solution source valve, a first drain valve, and a second drain valve.

43. The blood treatment device of claim 38, wherein the one or more valves comprise a first dialyzer inlet valve, a second dialyzer inlet valve, a first dialyzer outlet valve, a second dialyzer outlet valve, a first cleaning solution source valve, a second cleaning solution source valve, a first drain valve, and a second drain valve.

44. The blood treatment device of claim 38, wherein the first pump is operable to deliver and remove a predetermined volume of cleaning solution to and from the dialyzer.

45. The blood treatment device of claim 38, wherein the second pump is operable to deliver and remove a predetermined volume of cleaning solution to and from the dialyzer.

* * * * *