



(11) **EP 1 646 063 A3**

(12) **EUROPEAN PATENT APPLICATION**

(88) Date of publication A3:
28.02.2007 Bulletin 2007/09

(51) Int Cl.:
H01H 85/20 (2006.01) H01H 11/00 (2006.01)

(43) Date of publication A2:
12.04.2006 Bulletin 2006/15

(21) Application number: **05108313.7**

(22) Date of filing: **09.09.2005**

(84) Designated Contracting States:
AT BE BG CH CY CZ DE DK EE ES FI FR GB GR HU IE IS IT LI LT LU LV MC NL PL PT RO SE SI SK TR
Designated Extension States:
AL BA HR MK YU

(72) Inventors:
• **Kawamura, Hideki**
Ogasa-gun, Shizuoka (JP)
• **Suzuki, Yasuhito**
Ogasa-gun, Shizuoka (JP)
• **Sugiura, Tomohiro**
Ogasa-gun, Shizuoka (JP)

(30) Priority: **06.10.2004 JP 2004294214**

(74) Representative: **Brunner, Michael John et al**
Gill Jennings & Every LLP
Broadgate House
7 Eldon Street
London EC2M 7LH (GB)

(71) Applicant: **YAZAKI CORPORATION**
Minato-ku,
Tokyo (JP)

(54) **Fuse block**

(57) A fuse block 10 having a fusible link 19 fitted thereto and adapted to be attached to a junction box for connection of a wire harness 112 to the fusible link 19, wherein the fuse block 10 is detachably attached to the junction box while allowing LA terminals 110, 111 connected to wire harnesses 112, 113 and connectors 22, 23 connected to wire harnesses 114, 115 to be fitted therein thereto such that the terminals 110, 111 attached to the wire harnesses 112, 113 are electrically connected to the fusible link 19 at one part of the fuse block 10, whereas the connectors 22, 23 attached to the wire harnesses 114, 115 are electrically connected to the fusible link 19 at the other part of the fuse block 10.

FIG. 2

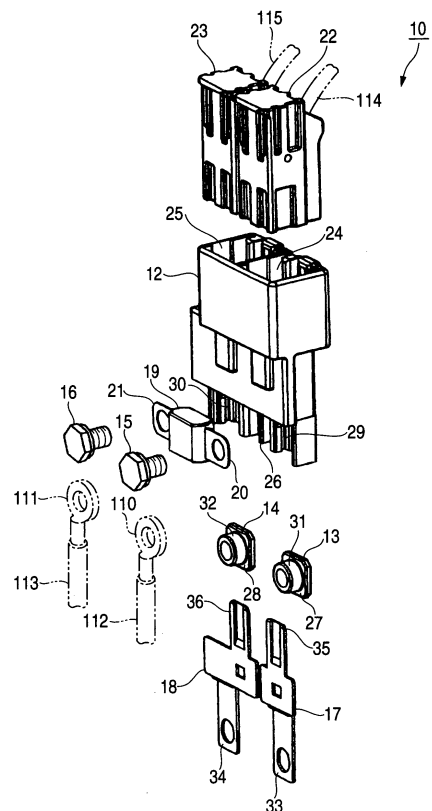

EP 1 646 063 A3



DOCUMENTS CONSIDERED TO BE RELEVANT			
Category	Citation of document with indication, where appropriate, of relevant passages	Relevant to claim	CLASSIFICATION OF THE APPLICATION (IPC)
X	US 5 403 193 A (ITO HIROKAZU [JP] ET AL) 4 April 1995 (1995-04-04) * the whole document * -----	1-8	INV. H01H85/20 H01H11/00
X	US 5 580 281 A (TAKEUCHI KUNIHICO [JP]) 3 December 1996 (1996-12-03) * the whole document * -----	1	
			TECHNICAL FIELDS SEARCHED (IPC)
			H01H B60R H01R
The present search report has been drawn up for all claims			
Place of search Munich		Date of completion of the search 22 January 2007	Examiner RAMIREZ FUEYO, M
CATEGORY OF CITED DOCUMENTS		T : theory or principle underlying the invention E : earlier patent document, but published on, or after the filing date D : document cited in the application L : document cited for other reasons & : member of the same patent family, corresponding document	
X : particularly relevant if taken alone Y : particularly relevant if combined with another document of the same category A : technological background O : non-written disclosure P : intermediate document			

1
EPO FORM 1503 03.82 (P04C01)

**ANNEX TO THE EUROPEAN SEARCH REPORT
ON EUROPEAN PATENT APPLICATION NO.**

EP 05 10 8313

This annex lists the patent family members relating to the patent documents cited in the above-mentioned European search report. The members are as contained in the European Patent Office EDP file on
The European Patent Office is in no way liable for these particulars which are merely given for the purpose of information.

22-01-2007

Patent document cited in search report		Publication date	Patent family member(s)	Publication date
US 5403193	A	04-04-1995	NONE	

US 5580281	A	03-12-1996	AU 685342 B2	15-01-1998
			AU 4337296 A	29-08-1996
			JP 3112390 B2	27-11-2000
			JP 8213109 A	20-08-1996

EPO FORM P0458

For more details about this annex : see Official Journal of the European Patent Office, No. 12/82