

FIG. 2.

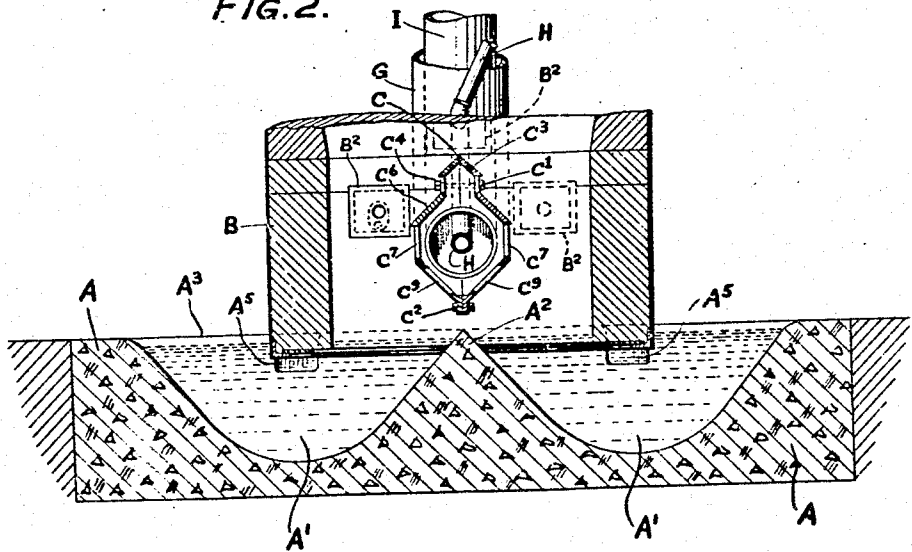

FIG. 3.

WITNESSES:

Robt. A. Mitchell
John Q. Berry

INVENTOR

James A. Herrick
 BY *Charles N. Butler*
 ATTORNEY.

UNITED STATES PATENT OFFICE.

JAMES A. HERRICK, OF NEW YORK, N. Y.

GAS-PRODUCER.

999,784.

Specification of Letters Patent.

Patented Aug. 8, 1911.

Application filed July 24, 1908. Serial No. 445,070.

To all whom it may concern:

Be it known that I, JAMES A. HERRICK, a citizen of the United States, residing in the city of New York, county of New York, and State of New York, have invented certain Improvements in Gas-Producers.

This invention is an improved gas producer designed particularly for burning small anthracite coal to produce gas for plants requiring a limited amount of power, but also adapted for producing large volumes of gas either from anthracite coal, or, with slight changes, from bituminous coal.

In the usual gas producers, of the suction type, for burning small anthracite coal, the following serious faults are encountered which it is the object of my improvements to correct. In prior producers of this type the constructions are complex, costly and difficult to operate: leakage of gas and uncontrolled ingress of air are common; viewing, poking and preventing cinders from building up from the sides are difficult so that producers cannot be run continuously; combustion is not regular owing to imperfect means for supplying and distributing air and steam; steam and heated air are supplied at considerable cost both for apparatus and operation, and the producer tops are heated so that they are frequently warped and destroyed.

The characteristic features of my improvements will appear from the following description of the accompanying drawings in illustration thereof.

In the drawings, Figure 1 is a vertical sectional view of a producer embodying my improvements; Fig. 2 is a horizontal sectional view thereof; Fig. 3 is a vertical sectional view of the lower part of the construction taken at right angles to the view shown in Fig. 1.

As shown in the drawings, the base A contains the water seal and ash basins A' separated by the ridge A² which terminates in an angle, the intersecting slopes forming the ridge being inclined so as to throw outward ashes falling thereon. The parallel walls A³, forming sides for the basins, carry the circular producer body B, the base having

below the general level thereof the piers A⁴ for supporting the base and the circular channels A⁵ communicating with the basins from which they receive water to seal the lower part of the body. Extending across the body above the ridge and parallel thereto is the blast box C which is formed in two similar parts separated on a longitudinal vertical plane and connected together by bolts C¹ and C² passing through the tops and bottoms thereof. The two parts of the blast box have the inclined tops C³ which join together to form a sharp ridge, the vertical walls C⁴ containing the apertures C⁵ immediately beneath the parts C³, the outwardly inclined walls C⁶ immediately beneath the walls C⁴, the vertical walls C⁷ containing the apertures C⁸ immediately beneath the walls C⁶, and the inwardly inclined walls C⁹ coming together under the ridge and containing the apertures C¹⁰. These apertures are placed and proportioned so that they deliver and distribute the blast in the most efficacious manner.

The producer body is provided with a manhole B¹ in line with the blast box, by which access is had to its interior through the rear end, and with capped poke holes B², by which access is had to the regions above and on either side of the blast box, to break up clinkers tending to form there. A hollow ring D, forming a closed channel having the diaphragm D¹ in its top, forms the upper part of the body. A funnel D² is connected through its bottom by the pipe D³ with the lower part of the channel and at a higher level discharges through an overflow pipe D⁴ into the channel A⁵, water being admitted to the funnel by a pipe D⁵ whence it flows into the channel D to the level of the outlet through the pipe D⁴. In the ring D, at suitable intervals, are the poke holes D⁷ having the cylindrical bearings D⁸ for balls D⁹ through which passes a closely fitting poker D¹⁰ into the producer body to stir the fuel, the poker being withdrawn from the balls and the latter turned to close the holes. Further openings D¹¹, passing through the ring at suitable intervals, provide means for viewing. These openings are

provided preferably with short tubes D¹² having the mica plate diaphragms D¹³ and the caps D¹⁴ for closing them, the caps being thrown back and a tube D¹⁵ fitted to a tube D¹² for the purpose of making an examination. By these arrangements stirring and viewing can be effected without material escape of gas or ingress of air, which are very objectionable. The body is covered by a top E having a channel formed by the flanges or walls E¹ and E² thereon, the latter also forming the wall of a fuel passage through the top. A pipe E³ admits water to this channel and a pipe E⁴ carries the overflow therefrom into the channel D.

A hopper F is connected to the top by a hinge F¹, has the laterally extending base F² adapted to rest on the flange E², and the flange or apron F³ depending into the channel, a hook E⁵ engaging the hopper to its seat on the top. A cone valve F⁴ closes the passage from the hopper through the top, being held up against its seat by a weighted lever F⁵ connected thereto and supported by the fulcrum F⁶ on the hopper. A tightly fitting hood F⁷ covers the hopper; in charging, the hood being removed by a lever F⁸ connected therewith and fulcrumed on a pivoted post F⁹ carried by the hopper. The hood may be detached from the hopper and placed over the flange E², for greater convenience of access to the interior and viewing through the capped aperture F¹⁰, the hopper having been turned backward on its hinge.

A conduit G extends from the ring D of the top to the inlet end of the blast box C in the bottom of the body, a valve G¹ controlling the admission of air to the top of the conduit. A pipe H, containing a valve H¹, leads from the interior of the upper and outer part of the ring D into the outlet from the conduit G to the blast box C, and creates suction through the conduit by discharging through its outlet steam or vapor evolved from the water in the channel through the action of the heat in the top of the body. The gas take off pipe I, connected with the interior of the top of the body by the passage D⁶ through the ring, is inclosed within the conduit G to the level of the outlet therefrom so that air flowing through this conduit on its way to the blast box is heated by the gas flowing in the pipe and the gas is cooled, the mechanism providing an economic temperature interchanger. It will be understood that flow through the pipe I will be facilitated generally by the suction of an engine or other apparatus (not shown) to which the gas is supplied, and the flow of air through the conduit G facilitated thereby.

A purge pipe J is connected to the pipe I exterior to the conduit G, and is provided

with the valved pipe J¹ for testing the gas and the sealed cap J² for opening the top, the pipe being used when lighting the fires, for carrying off waste gases, as a safety blow-off, and for obtaining gas to be tested.

The foregoing construction is practically leak proof and is satisfactorily cooled where the high temperatures are usually destructive, since the sealing basins are of unusual depth, the bottom of the body is entirely surrounded by water, the top of the body is formed by a hollow ring containing water, the parts of the top or cover in contact with the hot gases are water cooled, the connection of the hopper with the top is sealed and tight, and the passage through the hopper is securely closed by the tightly fitting valve and hood. The interior of the body can be poked and the fire examined very readily through the poke holes and viewing apertures, without egress of gas or ingress of air. The water that cools the top of the producer in so doing absorbs heat by which vapor is produced that is utilized in effecting the desired combustion. The air to be used to carry on combustion is given a desired increase in temperature by absorbing heat from the gas which it is desired to cool, and this air is distributed so that a proper portion thereof reaches all parts of the fuel. The mechanism is simple, inexpensive and not liable to get out of order. The ashes are thrown outward by the ridge into the basins which have their deepest parts beneath the wall of the body so that the ashes can be withdrawn readily.

Having described my invention, I claim:

1. A gas producer provided with a body having therein a blast box comprising an angular ridge, substantially vertical apertured walls beneath said ridge, outwardly inclined walls beneath said apertured walls, substantially vertical walls beneath said inclined walls, and inclined apertured walls beneath said last named apertured walls.

2. A blast box comprising divergent series of stepped inclined imperforate walls, the inclined walls of each series being separated by vertical perforate walls, vertical perforate walls disposed beneath the lowermost of the stepped walls, and inclined perforate walls disposed beneath said last named vertical walls.

3. A blast box having a plurality of pairs of generally sloping imperforate walls, which are interrupted by opposed perforate walls set inwardly of their line of slope, convergent perforate lower walls, and perforate walls interposed between said last named walls and one of said pairs of said sloping imperforate walls.

4. A blast box having a top ridge formed by a pair of divergent imperforate walls, a

bottom ridge formed by a pair of convergent perforate walls, a plurality of pairs of opposed vertical perforate walls between said top and bottom walls, and a pair of opposed
5 divergent imperforate walls interposed between said pairs of perforate walls.
In witness whereof I have hereunto set

my name this 11th day of July A. D. 1908, in the presence of the subscribing witnesses.

JAMES A. HERRICK.

Witnesses:

ROBERT JAMES EWING,
JOS. G. DENNY, JR.

Copies of this patent may be obtained for five cents each, by addressing the "Commissioner of Patents, Washington, D. C."