

APPARATUS FOR MIXING INGREDIENTS OF CONCRETE AND OTHER PLASTICS AND CEMENTS.

No. 304,366.

Patented Sept. 2, 1884.

Fig. 1.

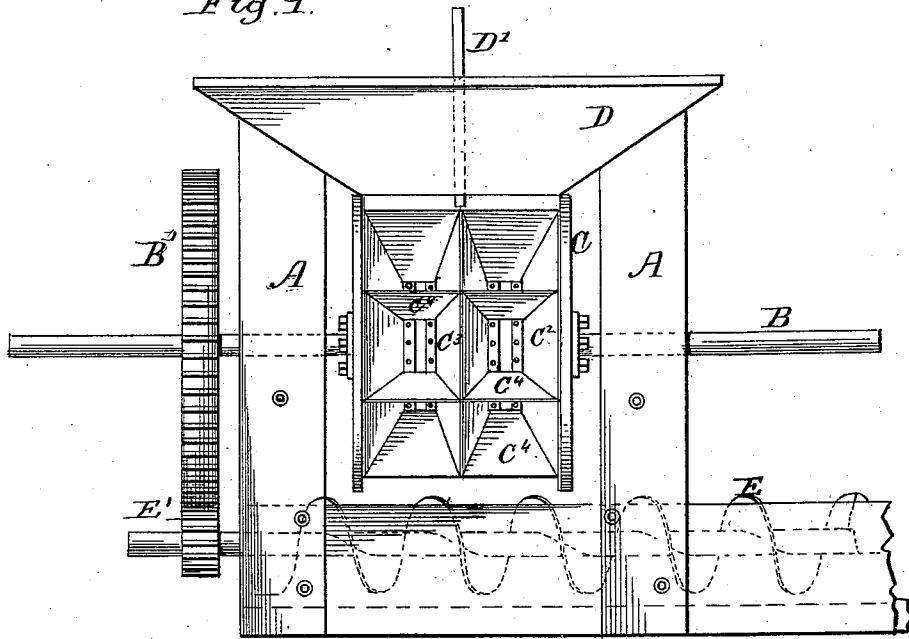
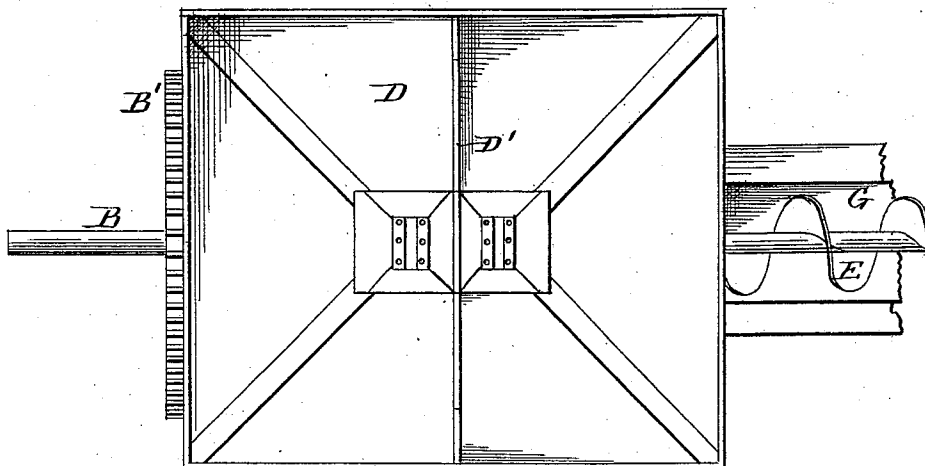

Fig. 2.



Witnesses:

L. C. Stills

W. R. Masson

Inventor:

Charles Sooy Smith

by E. O. Masson  
att'y.

C. SOOYSMITH.

APPARATUS FOR MIXING INGREDIENTS OF CONCRETE AND OTHER PLASTICS AND CEMENTS.

No. 304,366.

Patented Sept. 2, 1884.

Fig. 3.

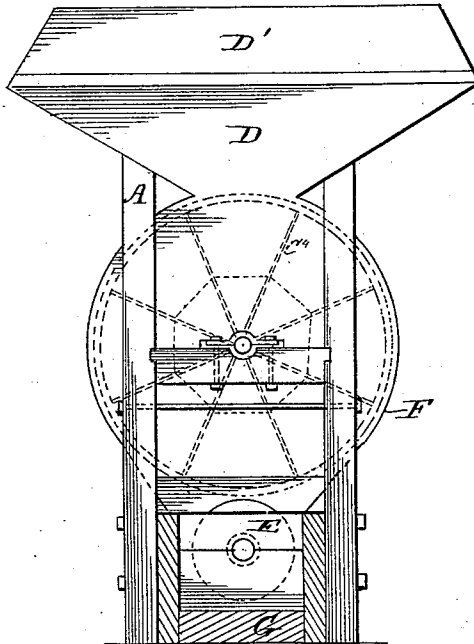

Fig. 4.

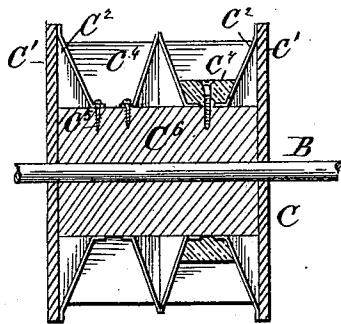
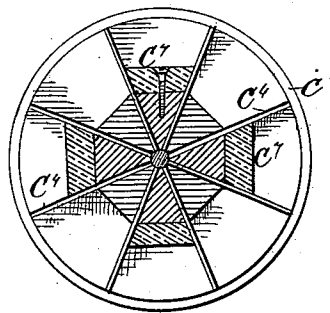

Fig. 5.



Witnesses:  
*L. C. Hills*  
*W. Masson*

Inventor  
*Charles Sooy Smith*  
 by *E. E. Masson*  
*atty.*

# UNITED STATES PATENT OFFICE.

CHARLES SOOYSMITH, OF CHICAGO, ILLINOIS.

APPARATUS FOR MIXING INGREDIENTS OF CONCRETE AND OTHER PLASTICS AND CEMENTS.

SPECIFICATION forming part of Letters Patent No. 304,366, dated September 2, 1884.

Application filed May 12, 1884. (No model.)

*To all whom it may concern:*

Be it known that I, CHARLES SOOYSMITH, a citizen of the United States, residing at Chicago, in the county of Cook and State of Illinois, have invented certain new and useful Improvements in Apparatus for Mixing Ingredients of Concrete and other Plastics and Cements, of which the following is a specification, reference being had therein to the accompanying drawings.

This invention has for its object the automatic proportionate subdivision of material in bulk of one or more kinds, and the subsequent admixture of such materials—as, for example, the mixture of sand and cement in forming concrete, and the proportionate measurement of any other materials employed in the manufacture of compositions of matter, and although herein set forth with particularity as regards the mixture of sand and cement in making concrete, the invention is applicable to and comprehends its use in mixing the ingredients of mortar, plaster, or any other composition of matter in which certain proportions of different materials, whether wet or dry, enter into the composition to be made.

Referring to the drawings, Figure 1 is a side elevation of the proportionate meter, (the covering thereof being removed,) and of a conveyer or mixer arranged to operate in connection therewith. Figs. 2 and 3 are respectively a plan and an end elevation of the apparatus shown in Fig. 1. Figs. 4 and 5 are respectively a longitudinal and transverse section of the automatic meter detached.

In any suitable frame-work, as A, is journaled a main shaft, B, upon which is mounted an automatic proportionate meter or measuring cylinder, C, above which is supported a hopper, D, and in this instance below which is arranged a mechanical mixer, E, which is driven by means of a pinion, E', meshing with a master-gear, B', mounted on the main shaft B, the pinion being mounted on the shaft of the mixer. The hopper D is provided with a partition, D', which is made to conform to the sides of the hopper, so that it may be moved within the hopper to divide it into separate compartments of equal or unequal capacity. Although but one partition D is here shown, several may be employed to adapt the appa-

ratus to operate upon several different materials when the measuring-cylinder is also adapted to that purpose, as hereinafter described.

The measuring-cylinder or automatic meter consists, essentially, of two disks, C'—one at each end thereof—the inner walls, C<sup>2</sup>, of which are preferably slanted or inclined, so as to facilitate the reception and delivery of material supported within the heads. One or more circumferential partitions, C<sup>3</sup>, having inclined walls, are arranged between the heads, so as to divide the cylinder into a series of compartments, one or more in number, and extending around the cylinder. These compartments, by means of transverse partitions C<sup>4</sup>, are again divided into other smaller compartments, so that a series of compartments, boxes, or buckets of a determined capacity is formed about the cylinder; and said series may be in number one or more—that is to say, when the circumferential partition C<sup>3</sup> is used there are two series of compartments, boxes, or buckets, and when two of said circumferential partitions are used there will be three series of boxes, in which case two partitions, D', would be required in the hopper, each of which partitions would be arranged in the same vertical plane with the partitions C<sup>3</sup>.

I have devised two methods of determining the capacity of the boxes in the measuring-cylinder, one of which is to form the inner inclined walls of sheet metal, having a flange adapted to be secured by screws C<sup>5</sup> to a wooden core, C<sup>6</sup>, of the cylinder, through which and the heads the main shaft B passes. By this construction of the wall of the box and of the circumferential partition C<sup>3</sup> they may be moved longitudinally upon the core, so as to vary the width of the box, while the transverse partitions C<sup>4</sup> may be in the same manner changed in their relative circumferential position and in the number employed, so as to vary the capacity of the box in that direction. Another method to change the capacity of the box is by the insertion therein of blocks or false bottoms C<sup>7</sup>, which are retained by screws passing therethrough into the core. In this latter method the partitions C<sup>3</sup> and C<sup>4</sup> may be constructed permanently within the cylinder; and these false bottoms may be used in all the

boxes of a series, or in alternate boxes, or in less than all the boxes, either successively or alternately, the alternate arrangement being clearly shown in Fig. 5.

5 The sheet-iron covering F is arranged about the cylinder, though not touching the same, to confine the materials in the box from the time they leave the hopper until they arrive at a point over the chamber, box, or trough G, in  
10 which the mixer E operates. Such mixer may be the ordinary spiral conveyer, as shown, or of any suitable construction, adapted or not to deliver the mixed material therefrom to other mechanism for further manipu-  
15 lation or to any receptacle, as desired.

The operation of the invention is as follows: Any materials—for instance, sand and cement—are placed, without regard to the quantity required in any proportionate admixture  
20 of the same, within the compartments of the hopper D, (the partition or partitions therein and in the mixing and measuring cylinder having been previously arranged,) so that as the boxes pass beneath the hopper they will receive their fill of the material therein at each  
25 side of the partition, and no more, the succeeding boxes on the cylinder being filled as they approach the mouth of the hopper and pass thereby. As arranged and shown, the boxes  
30 receive an equal quantity of the different materials in the hopper; but, as before described, the removal of transverse partitions C' in one series of boxes will enable that series to receive double the quantity of one of the materials in the hopper in proportion to one-half  
35 of the quantity in the other compartments of the hopper, and the quantities selected are held within the compartments by the covering or jacket F until said compartments arrive at a point over the trough G, when they  
40 are dropped simultaneously therein and carried by the conveyer or mixer, and while passing therethrough are thoroughly mixed.

45 Having described my invention and its operation, what I claim is—

1. The combination, with a hopper having

partitions, of a rotatable cylinder having adjustable compartments, boxes, or buckets, substantially as specified.

2. An automatic proportionate measuring- 50 cylinder comprising end walls and central circumferential partitions and adjustable transverse partitions, substantially as specified.

3. A rotatable measuring-cylinder comprising end walls, transverse partitions, and 55 means, substantially as described, for adjustably determining the capacity of the compartments formed by said partitions and end walls, substantially as specified.

4. A rotatable measuring-cylinder comprising 60 end walls and a circumferential partition and transverse partition, all of which are inclined to facilitate the entrance and discharge of material into and from the compartments 65 formed by the same, substantially as specified.

5. The combination of a hopper having an adjustable partition with a measuring-cylinder having adjustable partitions, substantially 70 as specified.

6. The combination of the hopper D, having the adjustable partition D', the cylinder C, having two series of boxes, a covering or jacket, F, and a mixer, as E, substantially as 75 and for the purpose set forth.

7. The measuring-cylinder C, comprising the heads C', the circumferential partitions C<sup>s</sup>, the transverse partitions C<sup>t</sup>, and the core C<sup>c</sup>, 80 substantially as shown and described.

8. The combination of the hopper D, having 80 the partition D', the cylinder C, constructed as described, and mounted upon the main shaft B, carrying the master-gear B', and the mixer E, adapted to be operated through the medium of the pinion E' and the gear B', 85 substantially as shown and described.

In testimony whereof I affix my signature in presence of two witnesses.

CHARLES SOOYSMITH.

Witnesses:

WILLIS CHRISTIE,  
E. L. ABBOTT.