

G. Clark.

Vacuum Grain-Drier.

N^o 71981.

Patented Dec. 10, 1867

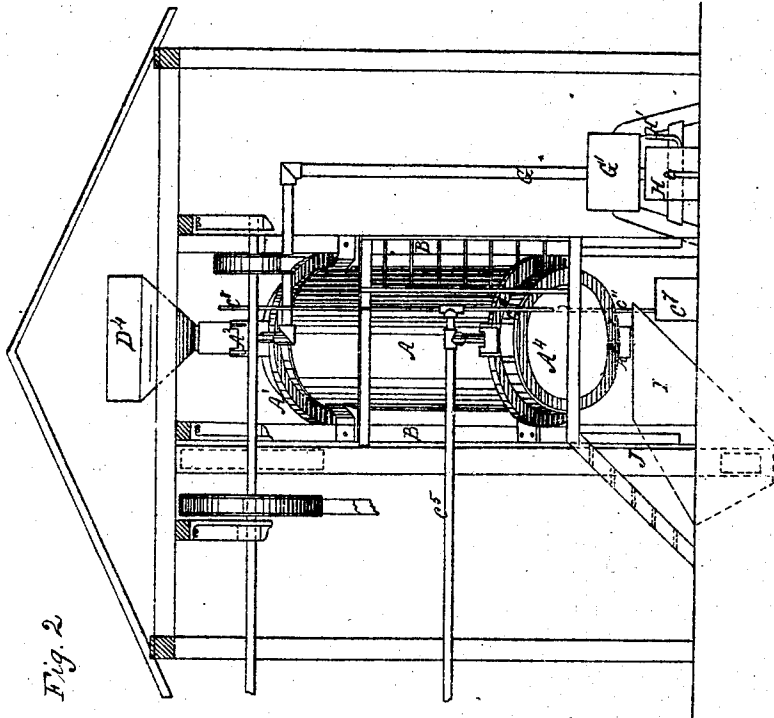

Fig. 2

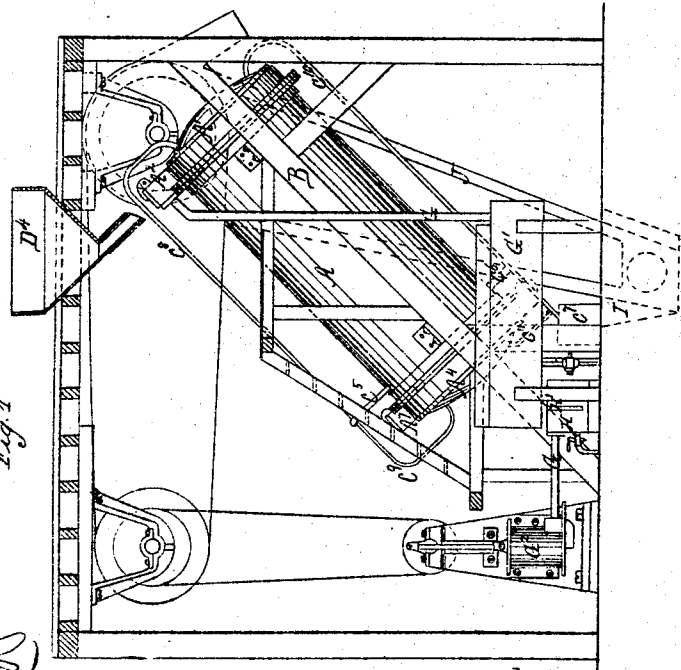

Fig. 1

Witnesses

Edward Wilhelm,
Gottlob Burkhardt,

Inventor
G. Clark

G. Clark.

Vacuum Grain - Drier.

N^o 71981

Patented Dec. 10, 1867

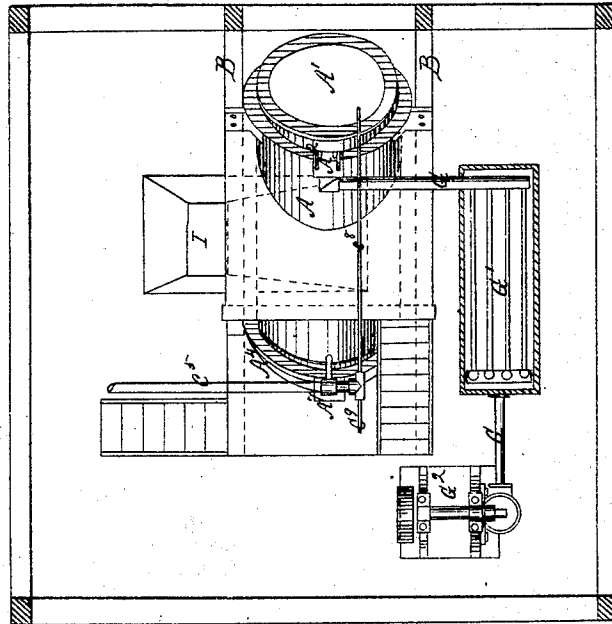

Fig. 1.

Witnesses

Edward Michelson
Gottlob Burkhardt

Inventor

G. Clark

United States Patent Office.

GEORGE CLARK, OF BUFFALO, NEW YORK.

Letters Patent No. 71,981, dated December 10, 1867.

VACUUM GRAIN-DRIER.

The Schedule referred to in these Letters Patent and making part of the same.

TO ALL WHOM IT MAY CONCERN:

Be it known that I, GEORGE CLARK, of the city of Buffalo, county of Erie, and State of New York, have invented a Vacuum Grain-Drier; and I do hereby declare that the following is a full, clear, and exact description thereof, reference being had to the accompanying drawings, making a part of this specification.

Kilns for drying grain, as heretofore constructed, have employed as the active agent in their operation currents of hot air, circulating around and between the kernels of grain, and absorbing and carrying off the moisture therefrom, and have required such construction and arrangement of the grain-floors of the kiln as would permit the use of manual labor, or equivalent mechanical apparatus, to keep the grain constantly in motion, to prevent it from being scorched or burned during the drying-process.

Previous inventions and improvements in this class have mostly had for their object the controlling of said hot-air currents, and their equal distribution to and through the grain in the kiln, and also the obtaining of the required movement to the grain during the drying-process.

In order to dry grain expeditiously in kilns of this class, it is necessary to use hot-air currents of a very high temperature, and it has been found to be a matter of very great difficulty, and requiring great skill in their management, to so regulate the temperature and distribution of the hot-air currents and the movement of the grain as to insure an equal and uniform drying of the grain, without scorching or burning the same.

It is a well-known fact that the temperature at which water boils or is vaporized decreases, upon the removal of atmospheric pressure, from 212° in atmosphere to 88° *in vacuo*, and it is the object of my invention to produce a grain-drying apparatus which will take advantage of this fact, and avoid the use of a high temperature, and the consequent necessity of keeping the grain in motion.

In view of the foregoing, the nature of my invention consists—

First. In the arrangement and combination of three essential features, consisting, first, of an air-tight cylinder or case, forming a chamber for the reception of the grain; second, of a system of steam or hot-air conducting-pipes or floors within said grain-chamber, and dividing the mass of grain therein, which heat said grain, by radiation, to the temperature required to expel and vaporize the water and moisture contained therein; third, of an appropriate air-pump or apparatus to produce and maintain a vacuum (partial) in said grain-chamber, and thereby reduce the temperature at which said vaporization of the moisture in the grain will take place to the lowest possible degree, and to carry off, expel, or condense the same.

Second. In several details of construction of the heating-pipes, and of the vacuum-producing apparatus.

In the accompanying drawings—

Figure I is a side elevation of my said grain-drying apparatus.

Figure II is a front elevation of same.

Figure III is a plan of same.

Figure IV is a vertical and longitudinal section of the air-tight cylinder or case forming the grain-chamber, showing, also, the arrangement of the steam heating-pipes therein.

Figure V is an end view of cylinder, with upper head removed, to show the steam heating-pipes.

Figure VI is an end view of cylinder, with lower head removed, to show heating-pipes, and valves controlling the discharge of the grain from the cylinder.

Like letters refer to like parts in each of the figures.

A represents the case or shell, of iron, forming the chamber for the reception of the grain. It is made cylindrical in form, as being best adapted to withstand the atmospheric pressure when the vacuum is produced therein, but any other form may be used. The cylinder is supported in an inclined position by a framework, B, the angle of inclination being such as will insure the free flow of the grain therein to fill the same, and its free discharge therefrom, which angle will be about forty-five degrees, more or less. The upper end of the cylinder is closed by a head, A¹, having an aperture and nozzle, A², for the feeding in of the grain to fill the chamber. This aperture is closed air-tight, when required, by a valve or cover, H³. The lower end of the cylinder is closed by a head, A⁴, similar to A¹, having an aperture and nozzle, A⁵, for the discharge of the grain from the cylinder, closed, when required, by a valve, A⁶. It also has a second aperture and nozzle, A⁷, with covering-valve, A⁸, through which aperture access may be had to the discharge-valves to operate the same.

C represents the steam heating-pipes, running longitudinally through the cylinder, and arranged in parallel rows, as shown in Figs. IV and V. The several rows of pipes are covered on their upper sides with sheet-iron plates, C¹, so as to form floors for the grain to lie upon, and are further covered on their lower sides by perforated sheet-iron plates, C², which permit the evaporation from the grain to rise into the spaces between the tubes and be carried off.

Each row of pipes has at its lower end a manifold-head, C³, with which each pipe of the row communicates. The manifolds are further connected and made to communicate with each other by branches, C⁴, (see Figs. IV and VI.) Each steam-pipe is closed at its upper end, and is divided by a partition, running longitudinally through it, but stopping short of the closed end, so that the steam may pass up on one side and back on the other side of the partition. The steam-supply pipe is shown at C⁵, and is supposed to lead to a suitable boiler or steam-generator. It opens into the upper manifold-head, and supplies the whole system of heads and pipes.

The steam-waste pipe is shown at C⁶, and leads from the lower manifold-head to a steam-trap, C⁷, which prevents the escape of the steam until after it condenses, making the whole heat thereof available.

The upper and lower cylinder-heads are made double, so as to form steam-chambers, A³, which are supplied with steam from the main steam-pipe C⁵, by branch pipes, C⁸ and C⁹, and have waste-pipes, C¹⁰ and C¹¹, connecting with the main waste-pipe C⁶, to the steam-trap C⁷. The heads of the cylinder are by this means kept warm, to prevent the evaporation from the grain condensing thereon. The grain-floors C¹ have upward flanges, C¹², turned at their sides, so as to leave a space, C¹³, between the grain and the cylinder, and to prevent the evaporation from the grain striking the cylinder and condensing thereon.

The grain is received into the cylinder A, through the nozzle A², from a hopper, D¹, above said nozzle, said hopper being supplied by a spout from a store-bin or an elevator, as the case may be.

The steam-pipes stop short by several inches of the upper cylinder-head, forming a chamber, D, for the reception of the grain as it is fed in through the nozzle A², to distribute the same to the several floors, the space C¹³ being closed by a flanged head, D¹, to prevent the entrance of the grain into said space. A gate or valve, D², is placed near the bottom of the chamber D, which, when closed, prevents the entrance of the grain to the lower floor, so that the upper floors may all be filled before the lower one, when, by stopping the supply and opening the valve, the grain in chamber D will be drawn therefrom on to the lower floor, leaving the chamber free to receive the evaporation as it rises from the grain. The valve D² is operated by a rod, D³, accessible through the nozzle A².

The grain is retained on the floors by valves E, hinged to the manifold-heads, and covering the ends of the grain-spaces between the floors. A rod, E¹, connects with all the valves, so that they may be opened or closed all together, access being had to this rod through the nozzle A². A space or chamber, E², is left between the manifold-heads and the cylinder-head for the valves to work in, and for the conduction of the grain from the several floors to the discharge-nozzle A².

G represents the exhaust-pipe, leading from the nozzle A², at the top of the cylinder, to a surface-condenser, G¹, and from thence to an air-pump, G². The condenser may be constructed in any common and well-known manner, as may also the air-pump. The operation of the air-pump will exhaust the air from the cylinder or grain-chamber, and produce a vacuum therein, more or less complete, according to the efficacy of the pump employed.

The cylinder being filled with grain, as before described, and the several apertures closed air-tight by their valves or covers, the air-pump may be set in motion, and the steam admitted to the heating-pipes. As the pipes become hot by the circulation of steam through them, they will radiate their heat into the surrounding mass of grain, and raise the temperature thereof. The operation of the air-pump will in the mean time produce a vacuum, more or less perfect, in and around the grain; and as soon as the temperature of the grain is raised to the required point, the moisture or water in the grain will begin to vaporize, and pass from the grain, in the form of steam, through the perforated plates C², into the spaces between the steam-pipes, and thence pass into the chamber D, from which it will be conducted, by the exhaust-pipe G, to the condenser G¹, and then condensed into the liquid state.

The temperature at which the vaporization will take place will depend upon the perfection of vacuum attained. Assuming the vacuum to be equal to eleven pounds, or twenty-two inches of mercury, which will be about the point attained in practice, the vaporization will take place when the grain receives a temperature of 150° to 155°, at which temperature no possible injury can result to the grain by the scorching or burning thereof. The vacuum will further cause the heat to radiate more quickly and uniformly through the grain, thereby insuring a more uniform drying thereof than could possibly be obtained by currents of hot air. The tendency of the vacuum is also to bring the moisture in the grain to the surface, so that the whole body of the kernels will be dried equally throughout, and not the surface only, as is generally the case in hot-air driers, especially when very high temperature is used.

By interposing a vessel or tank, H, between the condenser and air-pump, the product of the condensation of the vapor may be collected therein; and by the attachment of a graduated glass gauge, H¹, thereto, the exact amount of water taken from the grain at any stage of the drying-process may be seen at a glance. In its practical bearing, this is a very important consideration, since it enables the operator, after a little experience, to determine the proper time to arrest the drying-process.

As a further guide and assistance to the operator, the grain-chamber should be provided with a thermometer, to indicate the temperature therein, and also a vacuum-gauge, to indicate the degree of vacuum, and enable him to suit the temperature to the vacuum.

A device may also be attached to the cylinder by which small quantities of grain may be taken therefrom,

at any time during the drying-operation, to determine the actual condition of the grain at the time, and this may be done without destroying or injuring the vacuum.

When the grain is found to be sufficiently dry, air may be admitted to the cylinder to destroy the vacuum, so that the discharge and other nozzles may be opened, and the grain drawn off from the cylinder. In issuing from the cylinder, the grain falls into a hopper, I, from which it is taken by an elevator-leg, J, to a store-bin, or to a proper cooling-apparatus.

It is evident that the precise form and construction of the grain-chamber, or of the heating-pipes therein, or of the vacuum-producing apparatus, are not material to my invention. Hot air passing through pipes, or between double floors, may be used as the heating medium, in place of steam, if so desired, the main idea of the invention being the application of radiant heat to the grain, with the atmospheric pressure removed therefrom.

An injection-condenser may be used in place of the surface-condenser, if desired; but this is not advised, as it would prevent the use of the gauge-vessel H.

Having thus described my invention, what I claim, and desire to secure by Letters Patent, is—

1. The three essential features or parts—the air-tight grain-chamber, the radiating heating-pipes or floors, and the vacuum-producing apparatus—combined and operating substantially as herein set forth.
2. The arrangement of the steam heating-pipes within the grain-chamber, substantially as set forth.
3. The graduated gauge-vessel H, arranged as and for the purpose set forth.

GEORGE CLARK.

Witnesses:

EDWARD WILHELM,
GOTTLÖB BURKHARDT.