



US 20090242566A1

(19) **United States**
(12) **Patent Application Publication**
Witheridge

(10) **Pub. No.: US 2009/0242566 A1**
(43) **Pub. Date: Oct. 1, 2009**

(54) **MULTI-PRODUCT TANK**

Related U.S. Application Data

(76) Inventor: **Anthony J. Witheridge**, Batavia,
IL (US)

(60) Provisional application No. 60/820,425, filed on Jul. 26, 2006, provisional application No. 60/820,415, filed on Jul. 26, 2006.

Publication Classification

Correspondence Address:
CAROL WILSON
BP AMERICA INC.
MAIL CODE 5 EAST, 4101 WINFIELD ROAD
WARRENVILLE, IL 60555 (US)

(51) **Int. Cl.**
B65D 25/14 (2006.01)
(52) **U.S. Cl.** **220/495.01**

(57) **ABSTRACT**

A means of storing multiple bulk liquids inside one storage tank which involves the installation of flexible internal tank(s) where such internal tank(s) comprise at least partially rigid end caps (12) and flexible membrane side walls (14), and/or internal bladders (15). These internal tanks and/or bladders are compatible with physical conditions of large bulk storage tanks and potentially capable of storing thousand of tons. The development of multi-product tanks allows tank-farm operators great flexibility in the logistical operation of storing a range of incompatible liquids, and avoids exhaustive tank clean out procedures that are normally required when switching large tanks from one product to another product, especially where incompatible specifications are intolerant of cross-contamination.

(21) Appl. No.: **12/373,981**

(22) PCT Filed: **Jul. 23, 2007**

(86) PCT No.: **PCT/US07/74084**

§ 371 (c)(1),
(2), (4) Date: **Jan. 15, 2009**

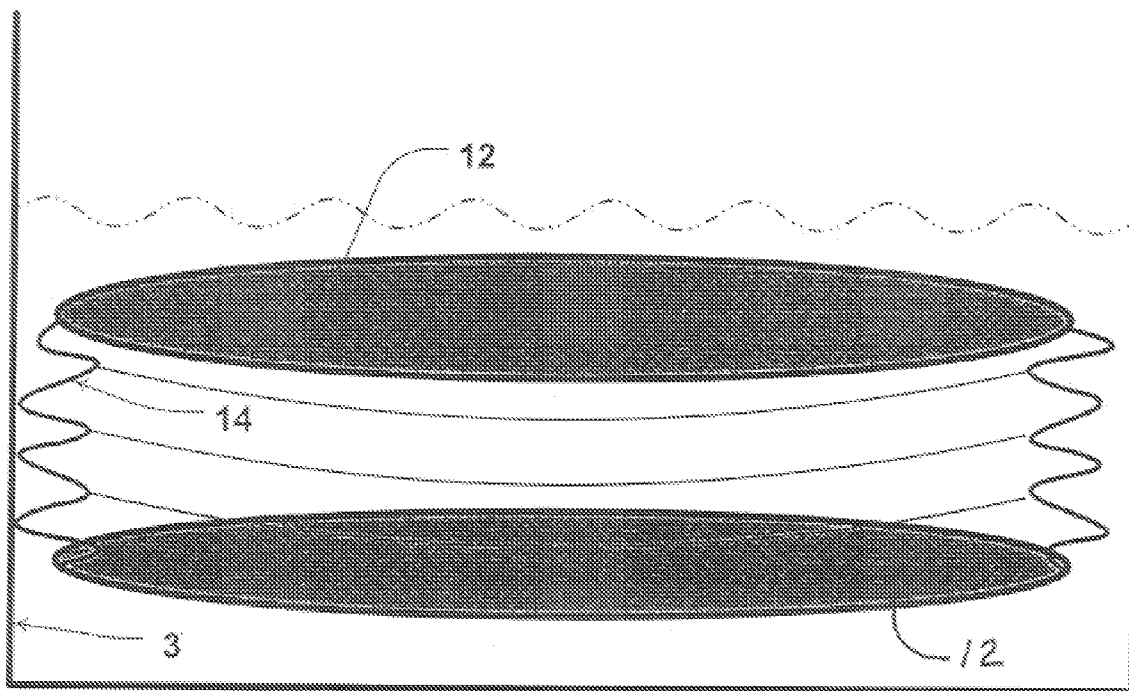

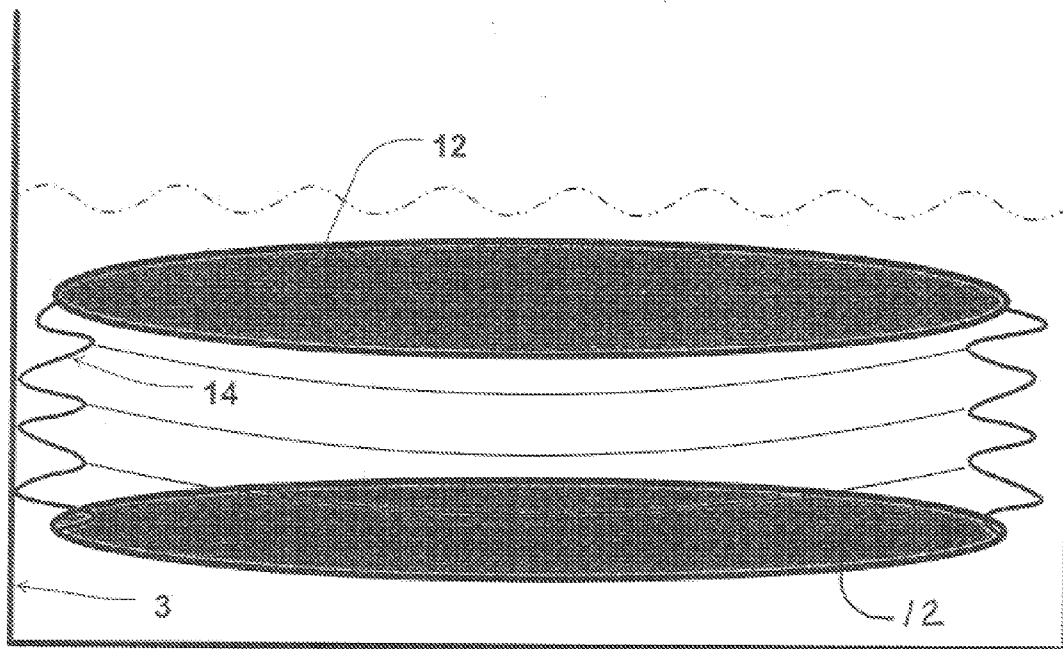
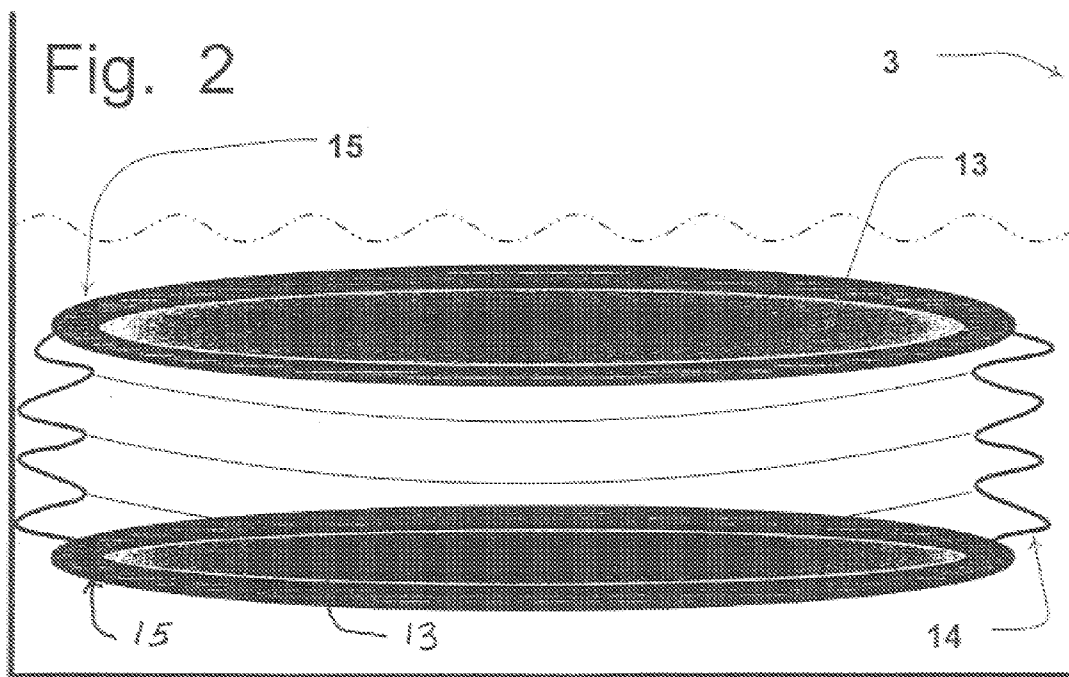

Fig. 1



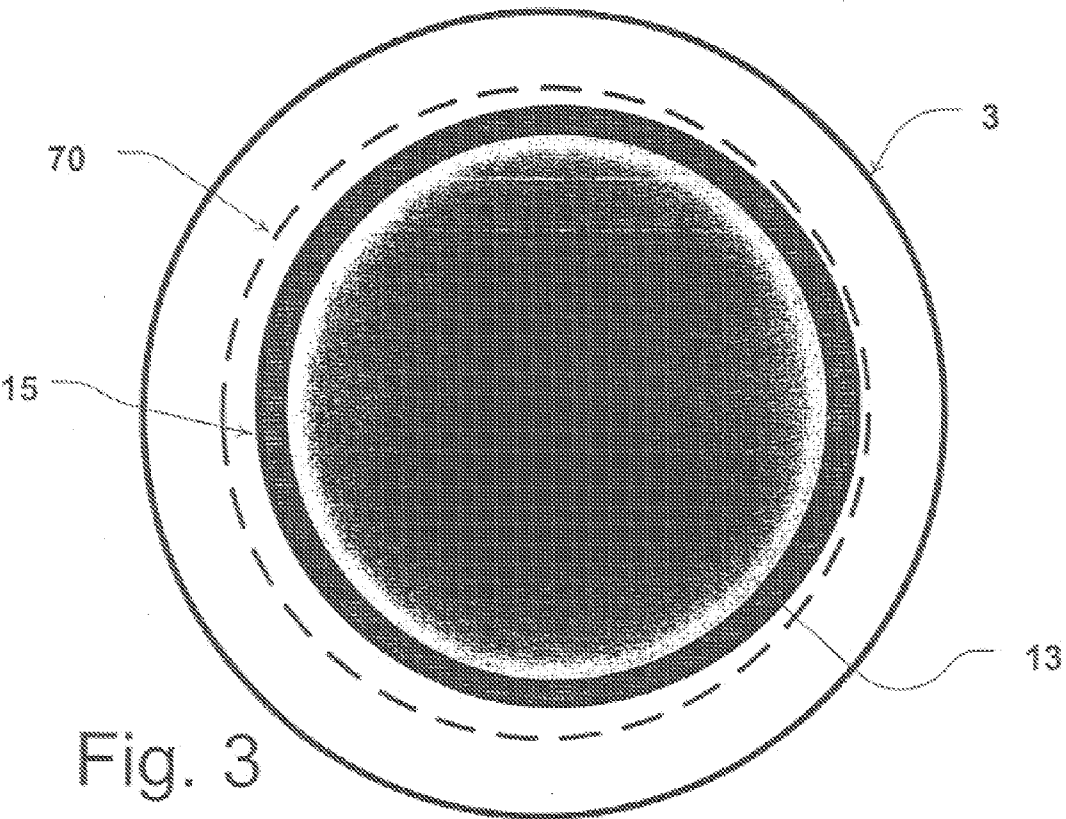
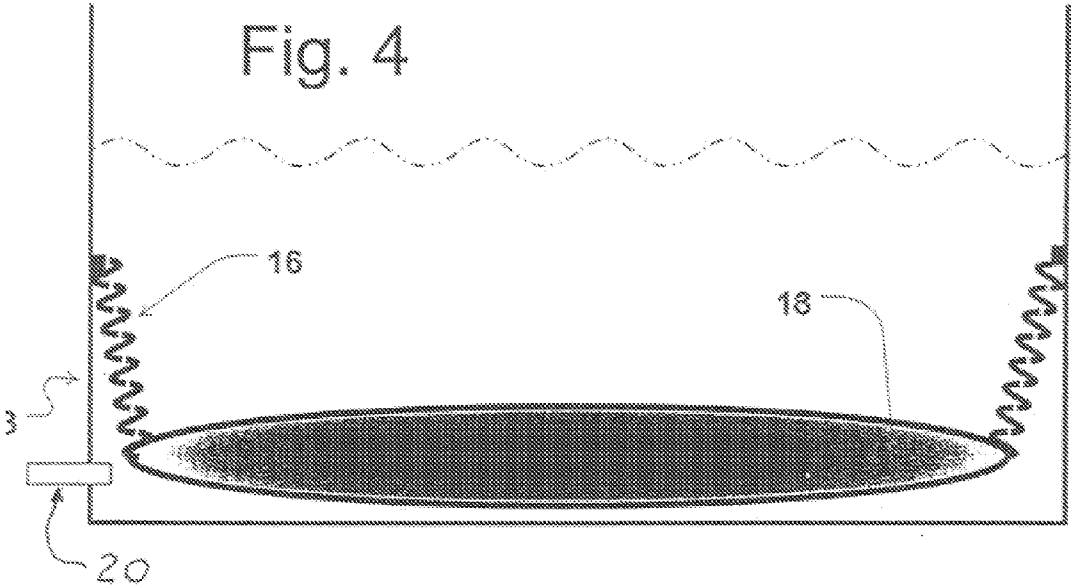
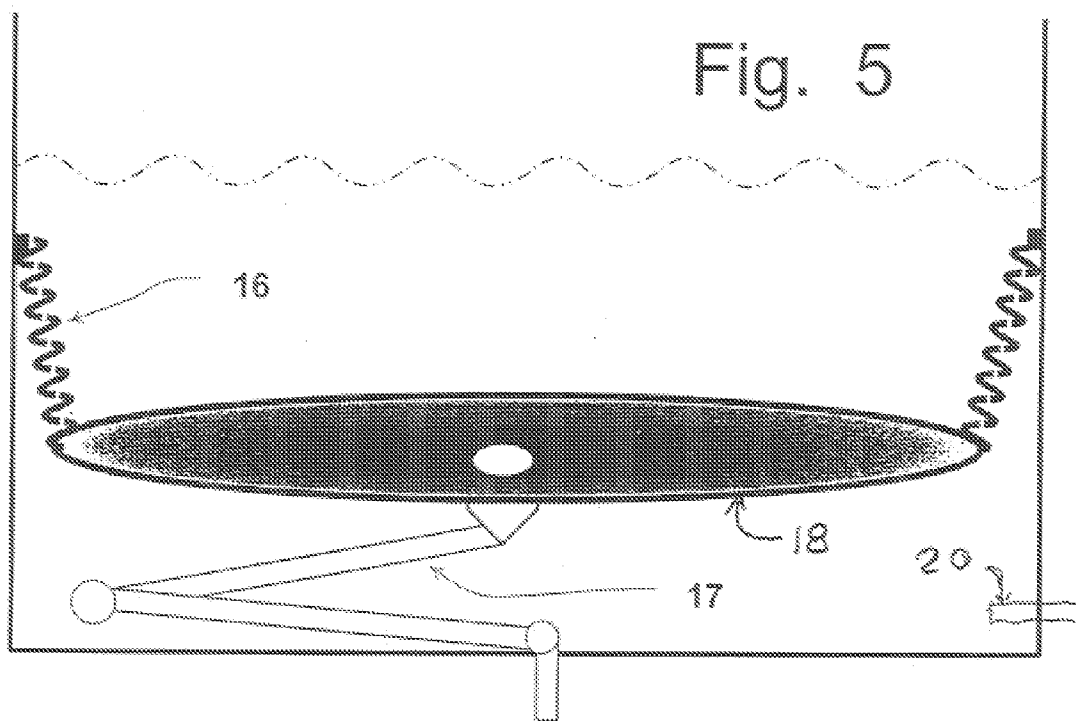

Fig. 3





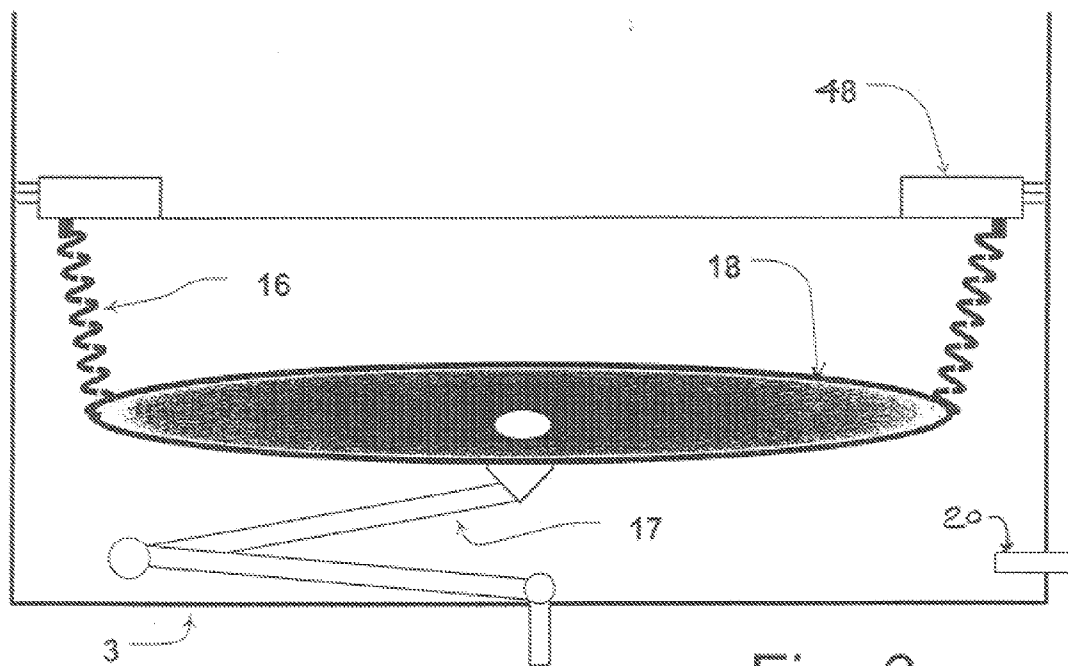

Fig. 6

Fig. 7

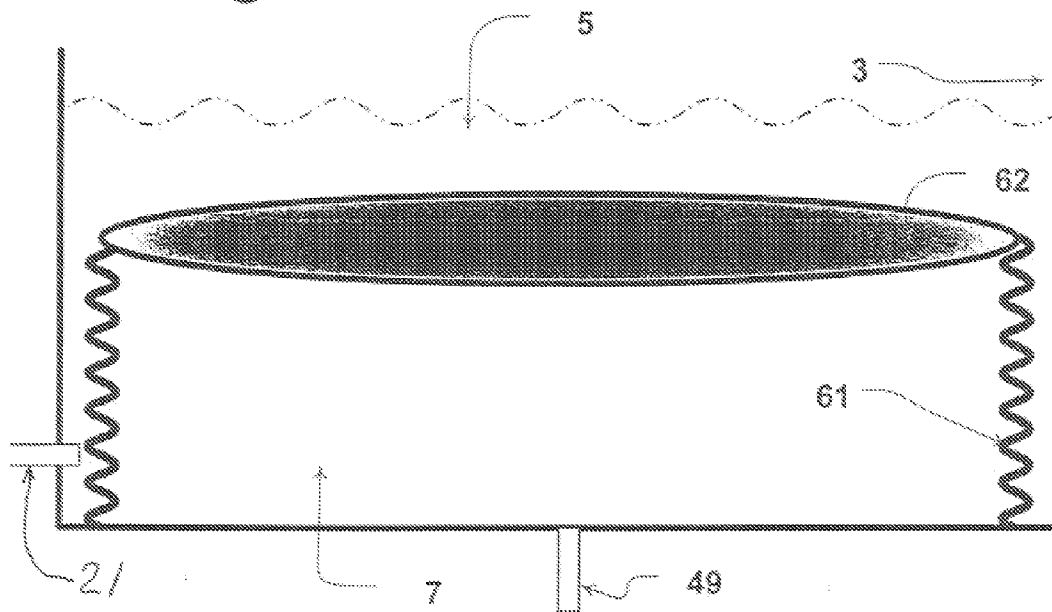
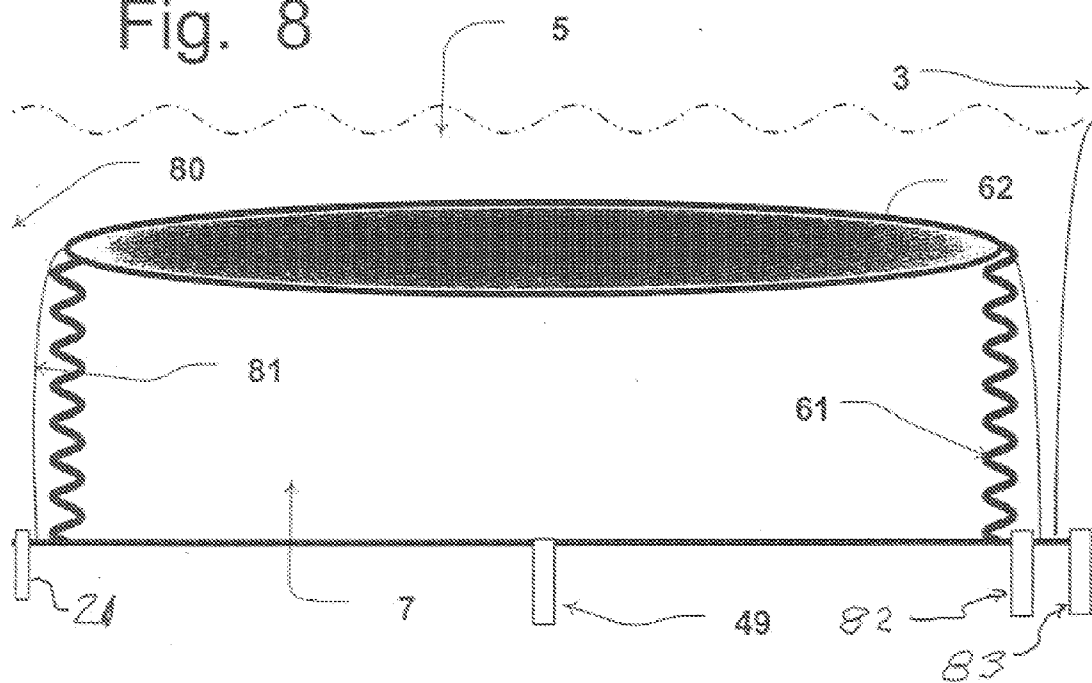

Fig. 8



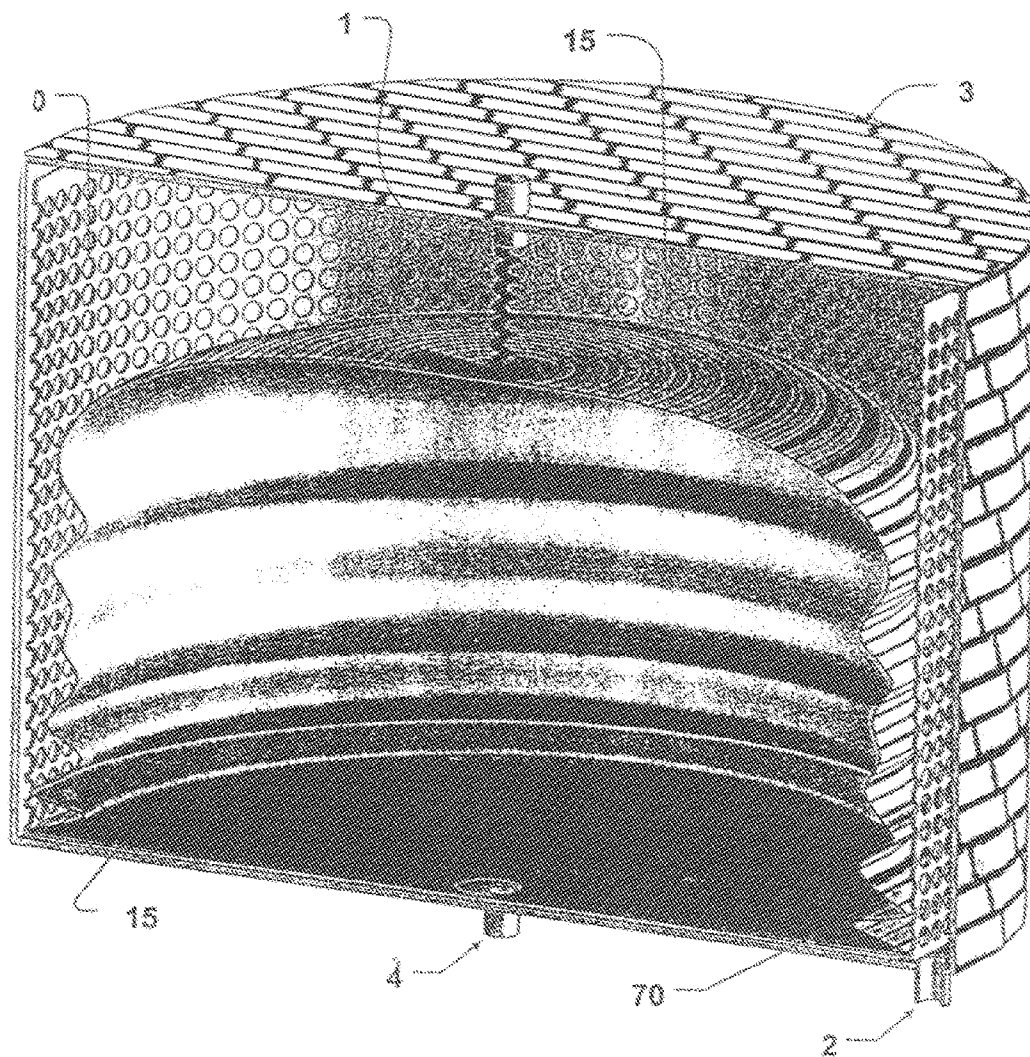

Fig. 9

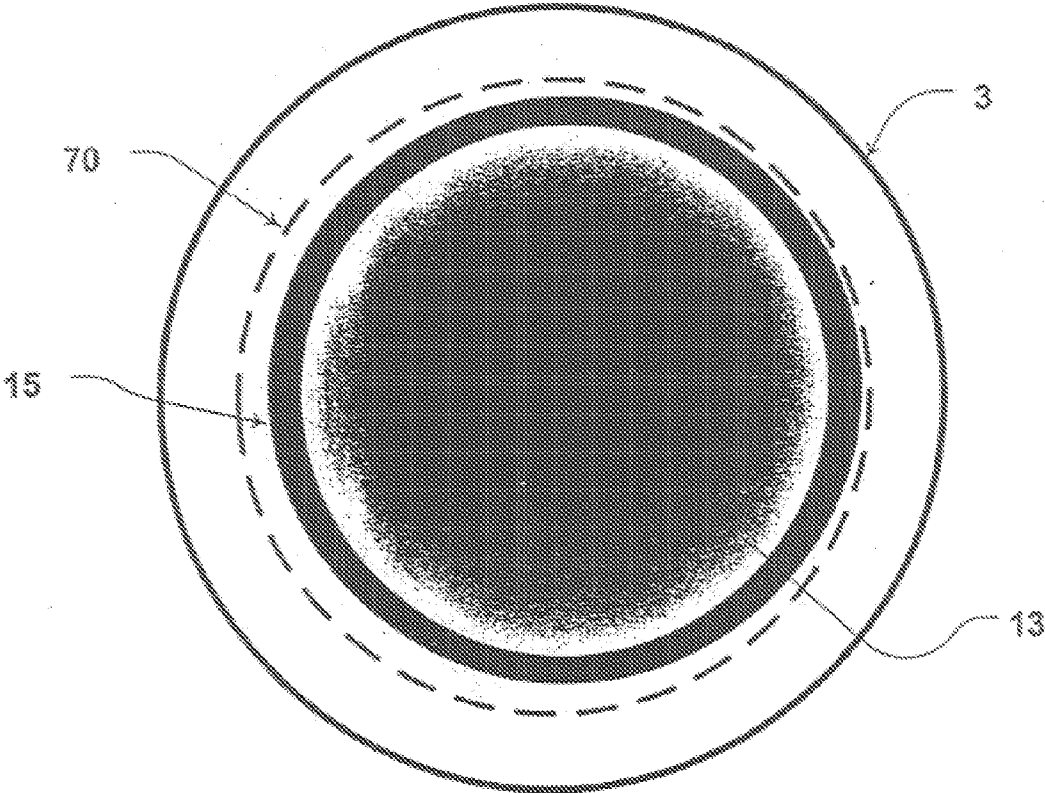

Fig. 10

MULTI-PRODUCT TANK

[0001] This application claims the benefits of provisional application Ser. No. 60/820,415 and provisional application Ser. No. 60/820,425, both filed 26 Jul. 2006, and each of which is incorporated herein by reference in its entirety.

TECHNICAL FIELD

[0002] The present invention relates to means of storing multiple bulk liquids inside one storage tank and, more particularly, involves use of internal tank(s) that compose at least one liquid-tight, flexible membrane or bladder.

BACKGROUND OF THE INVENTION

[0003] A number of processing industries require the use of multi-tank storage facilities to store feed stocks, intermediates and products. In particular, the processing of crude oil into a wide range of petroleum products and by-products requires the use of expansive multi-tank storage facilities called "tank farms." Depending on the processing being performed, these tank farms may range from several dozen tanks to several hundred tanks, many of which have storage capacities in excess of 50,000 cubic meters.

[0004] Due in part to the efforts to produce environmentally friendly products with very low levels of environmentally sensitive components, such as sulfur, a refinery must take extreme care not to cross-contaminate the product streams, either through residues in pipe work or when changing the use of one tank between different products. While it is practical to change the use of one tank from one liquid to another liquid with largely incompatible properties or specifications, it is not a process that can be implemented with out considerable delay (such as weeks) and cleaning expense. Such a change over generates large volumes of contaminated petroleum requiring reprocessing and requiring staff to enter and work inside a potentially hazardous environment.

[0005] Additionally, the operational logistics of a tank farm are complex. These facilities may be accepting super-tanker volumes of crude oil from different origins that require careful blending or totally separate processing. The delivery quantities are also fixed which can result in partially-filled tanks, e.g. only 10% of a 50,000 cubic meter tank is used for a short period. The ability to utilize 10% spare capacity in another tank, for example, one already 70% full with a different liquid, would be a real advantage.

[0006] Further, an oil refinery's tank farm must also handle wide fluctuations in product storage due to changing seasonal demands. For example the demand for heating oil can change rapidly with the onset of winter and the formulation of certain transportation fuels is often regulated to change between seasons. Accordingly, there is a need to store two or more liquids in a tank in order to fully utilize all tank volumes while preventing any cross-contamination. The ability to store two or more products in the same tank simultaneously can greatly simplify the storage logistics and reduce the total number of tanks required. This last point is significant because most refineries are in need of expanding capacity and are also faced with some degree of land lock, due to a combination having close neighbors and the high cost of approval and construction of additional tankage.

[0007] There are many examples of placing one container within another container, the most obvious example in the oil

industry being the use of double hulled super-tankers and the use of flexible bladders within rigid automotive fuel tanks (U.S. Pat. Nos. 3,968,896, (Giacoletti et al.); 3,949,720, (Zipprich et al.); and 6,360,729 (Ellsworth)). In these references, the purpose of the double containment is not for the purpose of storing multiple products in the same container, but more aligned with the goals of personal end environmental safety.

[0008] U.S. Pat. No. 4,818,151 (Moreland) discloses a containment system where the purpose is to increase safety by providing an additional barrier to contain leakage. In this example, a rigid under-ground storage tank is encased by a flexible bladder. Similarly, U.S. Pat. No. 4,763,805 (Strock) describes the use of a flexible bladder inside an underground storage tank designed to comply with secondary containment laws that prevent leakage from primary tank.

[0009] U.S. Pat. No. 3,943,873 (Hering et al.) is an example of multiple flexible bladders used in a ship's hull. Here, two separate bladders are used to create three separate compartments, two being used to hold oil on either side of the hull and the third central compartment to hold ballast water, such that the hydraulic instability of a partial load of oil in the hull is minimized.

[0010] U.S. Pat. No. 6,152,059 (Del Raso) is another example of flexible bladders being used to contain oil in a ship's hull. Here, the purpose is to provide an emergency containment, and should the integrity of the hull be compromised, then pumping systems can be used to transfer the oil into the flexible bladders to limit leakage.

[0011] There is a need for a multi-product tank system that permits the storage of multiple liquids in a tank thereby allowing maximum use of tank volumes and minimizing the cleansing requirements between storing incompatible liquids.

SUMMARY OF THE INVENTION

[0012] This invention relates to the disposition of a separate container or containers within a storage tank, wherein the internal container or containers are used to isolate at least one liquid from another liquid contained in the tank. To this end, present invention provides for a multi-product storage tank that comprises a tank shell, a support means such as a porous wall or screen capable of encircling a bladder disposed within the support means where such support means is attached to the inside of the tank shell. This structure permits the storage of a second liquid within the bladder and the storage of a first liquid within the space between the inside of the tank shell and the exterior of the bladder.

[0013] In one aspect the invention provides a multi-product storage tank comprising: (a) a first tank shell comprising a bottom and a side wall extending upwardly from the bottom thereby adapting the shell to contain liquid; (b) a second tank disposed within the first tank wherein the second tank comprises at least one partially rigid end cap and flexible, fluid-tight, membrane side wall attached to the end cap thereby defining a first space between the first tank shell and the second tank wherein a first liquid can be stored in isolation from the contents of the second tank.

[0014] In another aspect the invention provides a multi-product storage tank composing: (a) a first tank shell comprising a bottom and a side wall extending upwardly from the bottom thereby adapting the shell to contain a first liquid; (b) a support means disposed within the tank shell and fixed to the tank shell; and (c) a flexible, fluid-tight bladder disposed within the support means, wherein the flexible bladder is

adapted to storing a second liquid, thereby passing a first space between the first tank shell and the flexible bladder wherein a first liquid can be stored in isolation from the contents of the bladder.

[0015] In another aspect, the present invention provides for a multi-product storage tank having a novel configuration wherein a first rigid tank is provided to include a second internal tank wherein the second tank comprises at least one end cap wherein a portion of such end cap or end caps is rigid or semi-rigid and wherein the side walls of the second tank are fabricated with a flexible membrane material. This structure permits the storage of a second liquid within the second tank and the storage of a first liquid in the space between the inside of the rigid tank and the exterior of the second tank.

[0016] In specific aspects, this invention permits the storage of multiple petroleum products in one large storage tank, thus increasing the flexibility of storage options for a petroleum refining facility; however the invention has much wider industrial applications in other industries where liquid storage is required.

[0017] This invention provides a flexible storage system for tank farms by enabling multiple, potentially incompatible liquids to be stored in one tank. This results in multi-product tanks that can have the ability to store different liquids either simultaneously or sequentially with the added advantage of eliminating or reducing between-use cleanings.

[0018] Additionally, this invention provides means for the ability to separately fill or discharge the second liquid from the bladder and the first liquid from the tank disposed in the space between the tank shell and the bladder.

[0019] Where flexible bladders are used, this invention can comprise a membrane with sufficient tensile strength and chemical compatibility to ensure long-term separation of the applicable liquids. The bladder(s) can be connected to separate supply, sampling and discharge lines and essentially act as separate tank(s). The limitation being that the combined volume of the internal bladder or bladders and the primary tank must not exceed the volume of the primary tank alone.

BRIEF DESCRIPTION OF THE DRAWINGS

[0020] FIG. 1 shows an internal floating tank arrangement disposed within tank 3 where the end-caps 12 are rigid and the cylindrical side wall 14 comprise flexible, fluid-tight membrane material.

[0021] FIG. 2 shows an internal floating tank arrangement disposed within tank 3 where the end-caps are comprised of a rigid annulus 15 and a flexible, liquid-tight membrane 13 and again, the cylindrical side wall 14 comprises flexible material.

[0022] FIG. 3 shows an internal floating tank arrangement similar to FIG. 2 where the end-caps are comprised of a rigid annulus 15 and a flexible membrane 13; however, in this case the floating tank storing an isolated liquid is partially restrained by a porous wall 70. Such a restraining wall may vary considerably in size, and can encircle the entire second tank, or it could be a relatively small barrier to shield the internal second tank from highly turbulent flows during the filling of the first or second tank. The porous wall can be composed of a rigid wall of perforated metal or other suitable polymer or composite material, or comprise of a flexible wall such as a chain-linked fence or equivalent mesh like material that is suitably restrained to minimize contact with the inner wall of the outer tank. Such a restraint may be include a

material having a very low level of rigidity such as an open-cell foam similar to that used for safety in gasoline tanks of racing cars.

[0023] FIG. 4 shows a first tank 3 wherein stored liquids are isolated by means of end cap 18 and a flexible conical side wall 16 attached to the inside wall of the first tank. The smaller end of the flexible conical side wall 16 is connected to the end cap. The first tank 3 has a discharge and filling means 20 that is in flow communication with the liquid located below the end cap.

[0024] FIG. 5 shows an arrangement very similar to that shown in FIG. 4, and details conduit 17 that is suitable for the filling and the discharge of the liquid located above the end cap.

[0025] FIG. 6 shows how the arrangement in FIG. 5 can be configured to incorporate a floating roof 48. The larger end of the flexible conical side wall 16 is attached to the floating roof.

[0026] FIG. 7 details an internal second tank having flexible cylindrical side wall attached to the base of a rigid first tank 3 and to a roof 63. The second tank isolates the contained liquid 7 from another liquid 5 within the first tank. The second tank has a discharge and filling means 49 that is in flow communication with the liquid 7. The first tank 3 has a discharge and filling means 21 that is in flow communication with the liquid 5. Roof 62 can comprise of a combination of rigid and flexible materials.

[0027] FIG. 8 details an arrangement similar to that shown in FIG. 7, which includes two optional membranes 80, 81 disposed to allow full discharge of the first liquid 5 while maintaining a quantity of second liquid 7 in storage. In this case, either or both optional membranes should be filled with a liquid such as process water through filling and discharge means 82 and 83, thereby providing hydraulically support to the flexible cylindrical side wall 61, and aid in discharge of the surrounding liquid 5, which would otherwise be trapped between the outer tank wall and the inner flexible tank wall. Furthermore, this arrangement not only relieves the expansion stresses on the flexible cylindrical side wall 61 when the outer liquid 5 is drained below the roof of the inner tank, but also provides a smooth lubricated surface 80 and 81 for the inner flexible side wall to slide vertically as it is filled or discharged.

[0028] FIG. 9 depicts a cross-section through a perspective view of another aspect of the multi-product tank of the present invention. Outer tank 3 has a discharge and filling means 2 that is located between an outer, liquid-tight cylindrical tank wall 3 and an inner, cylindrical, porous wall 70. The porous wall is depicted as a cylinder of perforated metal plate affixed to the base of the tank 3. Secondary liquid is contained within bladder 15, which is restrained by the porous wall 70. Bladder 15 is shown with two of its primary connections, a fill and discharge port 4 and a vent conduit 1 to control the buoyancy effects of gases that may be present.

[0029] FIG. 10 shows a plan view of a tank similar to FIG. 9; where the flexible cylindrical side wall of the bladder is partially restrained by a porous wall 70. Such a restraining wall may vary considerably in size, and can encircle the entire bladder, or it could be a relatively small barrier to shield the bladder from highly turbulent flows during the filling of the tank or bladder within the tank.

DETAILED DESCRIPTION OF THE INVENTION

[0030] This invention provides a more flexible set of storage logistics for the operation of tank farms by enabling two

or more, potentially incompatible liquids to be stored in one tank. To this end novel configurations of a rigid tank are provided that in one aspect includes a secondary internal container with flexible surfaces such as a bladder capable of allowing the bulk of the secondary container to be discharged separately from the contents of the primary, outer, rigid tank. In another aspect, at the invention discharged. Such can be employed in the conversion or retrofitting of single-use tanks into multi-product tanks that have the ability to store different liquids either simultaneously or sequentially with the advantage of eliminating between-use cleaning that may consume weeks of tank down-time while providing efficient use of tank volume.

[0031] In one aspect of this invention addresses the needs of petroleum tank farm operators, where most at the tanks are thirty to sixty meters or more in diameter, where the time and effort required to clean these large tanks between multiple product storage tasks is not insignificant. The invention, however, is applicable across a wide range of industries and tank sizes.

[0032] The second tank disposed with the first tank may be comprised of certain rigid elements in combination with flexible elements. For example, FIG. 1 shows an embodiment of the invention where rigid end caps are attached to a flexible membrane cylindrical section. Further in FIG. 2, shows rigid disk end-caps comprised of a rigid annulus with an inner, flexible membrane. In a preferred embodiment of the invention, the flexible membrane would be a fiber reinforced polymer such as urethane, which may or may not include a metallic or other impervious inner layer. Clearly, many structural combinations of this invention can be developed by those skilled in the art without detracting from the novelty or benefits of the invention.

[0033] Another variant of this invention is the use of a flexible wall attached to a rigid or semi-rigid disk end cap, as depicted in FIGS. 4, 5, 6 and 7. FIGS. 4 and 5, depict a flexible cylindrical or conical wall of an internal container, attached at one end to the rigid wall of the external tank and attached at the other end to a disk end cap. The disk and walls having the ability to keep the two liquids separate and the disk can travel from the bottom to the top of the tank. The flexible section can be attached to the upper or lower section of the tank wall, however, in using this configuration it is preferred that the attachment point is centrally located to minimize the materials of construction, which is achieved because only half the height of flexible tank wall need be installed to enable spanning from the tank top to the floor. It is also preferred that the disk and walls be suitably ballasted to greatly neutralize any density differences between the intended storage liquids. Such ballasting can be dynamically adjusted by adding or removing fluids from small bladders attached to the inner tank or tanks. Wherein, the fluid used is of either a significantly higher or lower density than the liquid it displaces. Alternatively, this ballasting can be implemented by adjusting the length of cables connected between the top of the inner tank and the roof of the outer tank. This dynamic ballasting could also be integrated with self-contained level sensing transmitters and/or inclinometers, such that the disk can be leveled, and these controls or equivalent controls are applicable to all applications of this invention. Such sensors may be encapsulated or otherwise sealed and may include small, two or three axis, inclinometer chips and miniaturized transponders programmed to send data when requested or at infrequent times or if pre-set limits are exceeded. Using current technology,

these devices could be powered continuously for over fifteen years using small lithium batteries. A transponder and data processing unit external to the tank could be used to analyze the sensor data and activate valves, pumps or winches as needed to adjust the inner tank's buoyancy or inclination as appropriate. Another means of accomplishing the same goal may include similarly sealed and powered electronics that respond to a signal emitted from some reference point within the tank. The response delay from each of the sensors would allow detector units to triangulate their locations, and the results used to effect the buoyancy as described earlier or to simply monitor the volume of the inner tank.

[0034] Aspects of the invention shown in FIGS. 4 and 5 can also use different attachment points such as the tank roof or the base. Many petroleum tanks are constructed with an internal floating-roof, and FIG. 6 depicts an arrangement wherein the end cap disk is attached to a flexible, circular wall, which is attached at the other end to the floating roof 18. This example also depicts one method of plumbing the secondary containment volume, by using an articulated arm drain, which is not an uncommon technique in the petroleum industry for draining floating roofs. Further development of this concept could also be comprised of an attachment of flexible walls to a floating annulus, which may be separate from any roof structure.

[0035] FIG. 7 shows a concept similar to that in FIG. 4, when attached to the tank's base, which greatly simplifies the external plumbing logistics. Here the flexible walls are shown connected to a flexible disk, but the disk and walls can be comprised of any combination of flexible and rigid components. Furthermore, as depicted in FIG. 8, the arrangement can include additional flexible walls 80, and 81, between the rigid tank wall and the inner, second tank, respectively. The third and/or fourth walls can be inflated with a separate fluid to enable the bulk of the primary storage tank to be drained below the level of the secondary containment, while minimizing stress on the secondary containment wall and avoiding contact or shear against the rigid tank wall.

[0036] In a particularly useful aspect of the invention, internal secondary container can be comprised of a free-form bladder shape that can be filled and emptied from pipe work attached to the tank walls, base or from above. This bladder may be composed of a membrane with sufficient tensile strength and chemical compatibility to ensure long term separation of the liquids. This bladder may be constrained as shown in FIG. 2 within the outer tank 3 by a variety of means such as porous wall 70, such that hydraulic pressure and turbulence generated during the filling (or emptying) of the tank does not overly stress the bladder 15 having liquid 13 contents or its connections.

[0037] In such an embodiment of the invention, the bladder will be fabricated with a flexible membrane that can comprise a fiber reinforced polymer such as urethane, which may or may not include a metallic or other impervious inner layer. It is understood that the bladder need not be entirely flexible and may contain sections of non-flexible materials or components. The support is typically a porous wall but can also comprise a rigid wall of perforated metal or other suitable polymer or composite material, or comprise of a flexible wall such as a chain-linked fence or equivalent mesh like material that is suitably restrained to minimize contact with the inner wall of the outer tank. Such a restraint may include a material having a very low level of rigidity such as an open-cell foam similar to that used for safety in gasoline tanks of

racing cars. Clearly, many structural combinations of this invention can be developed by those skilled in the art, without detracting from the novelty or benefits of the invention.

[0038] It is understood that the present invention also comprehends the use of wireless sensors capable of monitoring the position or orientation of the bladder. Additionally, buoyancy adjusting devices attached to the bladder or associated piping can also be utilized. For instance, the bladder's upper and lower surfaces be suitably ballasted to greatly neutralize any problematic density differences between the intended storage liquids and to adjust the bladder's attitude. Soon ballasting can be dynamically adjusted by adding or removing fluids from small bladder compartments attached to bladder's surfaces. Wherein, the fluid used is of either a significantly higher or lower density than the liquid it displaces. Alternatively, this ballasting can be implemented by adjusting the length of cables connected between the top of the main bladder and the roof of the outer tank. This dynamic ballasting could also be integrated with self-contained level sensing transmitters and/or inclinometers, such that the disk can be leveled, and these controls or equivalent controls are applicable to all applications of this invention. Such sensors may be encapsulated or otherwise sealed and may include small, two or three axis, inclinometer chips and miniaturized transponders programmed to send data when requested or at infrequent times or if pre-set limits are exceeded. Using current technology, these devices could be powered continuously for over fifteen years using small lithium batteries. A transponder and data processing unit external to the tank could be used to analyze the sensor data and activate valves, pumps or winches as needed to adjust the bladder's buoyancy or inclination as appropriate. Another means of accomplishing the same goal may include similarly sealed and powered electronics that respond to a signal emitted from some reference point within the tank. The response delay from each of the sensors would allow detector units to triangulate their locations, and the results used to affect the buoyancy as described earlier or to simply monitor the volume of the inner tank.

What is claimed is:

- 1. A multi-product storage tank comprising:
 - (a) a first tank shell comprising a bottom and a side wall extending upwardly from the bottom thereby adapting the shell to contain liquid;

- (b) a second tank disposed within the first tank wherein the second tank comprises at least one partially rigid end cap and flexible, fluid-tight, membrane side wall attached to the end cap thereby defining a first space between the first tank shell and the second tank wherein a first liquid can be stored in isolation from the contents at the second tank.
- 2. The multi-product tank of claim 1, wherein the second tank comprises two end caps where one or both of the end caps comprises a rigid outer annulus.
- 3. The multi-product tank of claim 1, wherein the second tank is restrained from direct contact with the side wall of the first tank shell.
- 4. The multi-product tank of claim 1, wherein the second tank is disposed within a porous and or flexible support means positioned between the second inner tank and the side well of the first tank shell, wherein the support means is adapted to restrain the second tank from direct contact with the side wall of the first tank shell.
- 5. The multi-product tank of claim 1, wherein the second tank has its attitude monitored and adjusted to ensure stable floating dynamics.
- 6. A multi-product storage tank comprising:
 - (a) a first tank shell comprising a bottom and a side wall extending upwardly from the bottom thereby adapting the shell to contain a first liquid;
 - (b) a support means disposed within the tank shell and fixed to the tank shell; and
 - (c) a flexible, fluid-tight bladder disposed within the support means, wherein the flexible bladder is adapted to storing a second liquid, thereby defining a first space between the first tank shell and the flexible bladder wherein a first liquid can be stored in isolation from the contents of the bladder.
- 7. The multi-product tank of claim 6 wherein the tank further comprises wireless sensors capable of monitoring the position or orientation of the bladder.
- 8. The multi-product tank of claim 6, wherein the tank further comprises buoyancy adjusting devices attached to bladder or any piping associated with the bladder.
- 9. The multi-product tank of claim 6 wherein the support means comprises a ridged porous wall.
- 10. The multi-product tank of claim 6 wherein the support means comprises a flexible wall.

* * * * *