

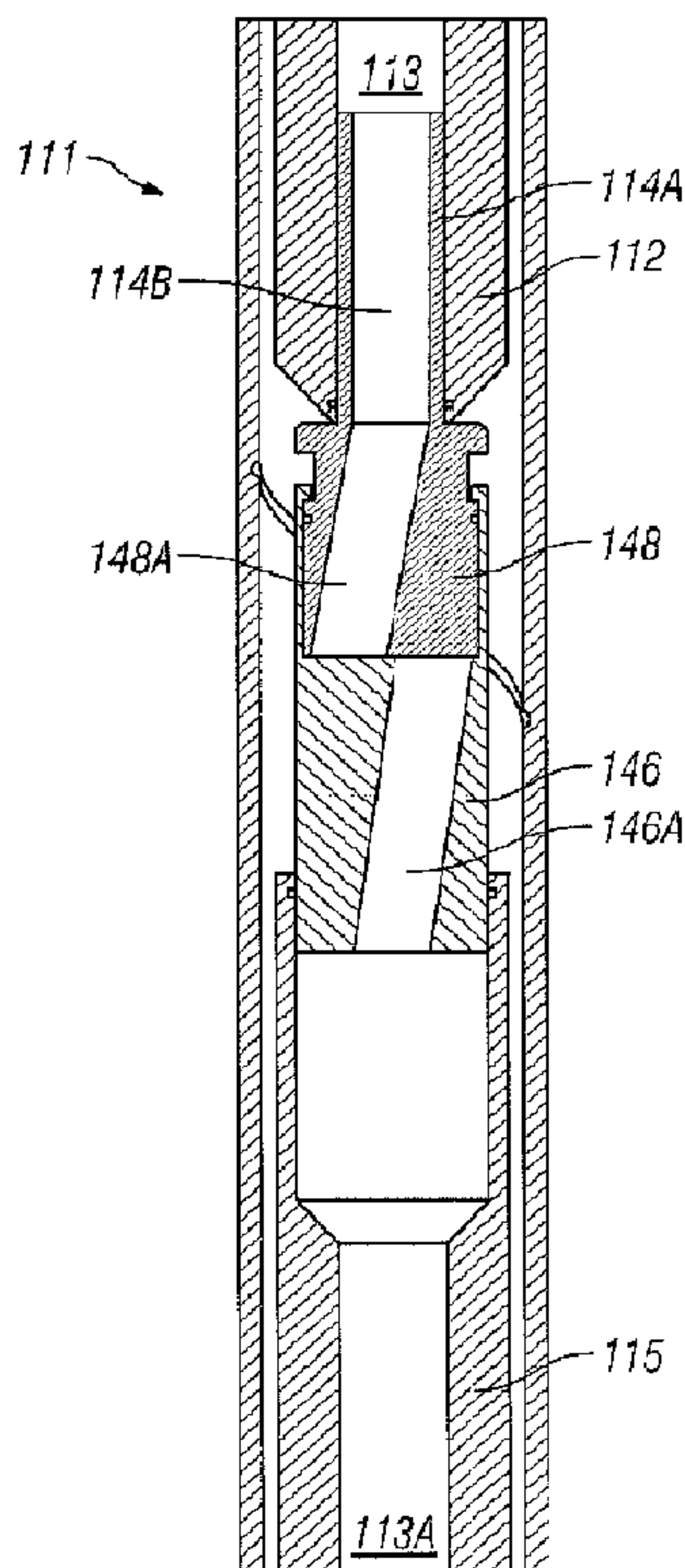

(86) Date de dépôt PCT/PCT Filing Date: 2013/02/06  
 (87) Date publication PCT/PCT Publication Date: 2013/09/06  
 (45) Date de délivrance/Issue Date: 2019/12/17  
 (85) Entrée phase nationale/National Entry: 2014/08/26  
 (86) N° demande PCT/PCT Application No.: EP 2013/052320  
 (87) N° publication PCT/PCT Publication No.: 2013/127610  
 (30) Priorité/Priority: 2012/02/28 (US13/406,979)

(51) Cl.Int./Int.Cl. *E21B 21/10* (2006.01),  
*E21B 21/12* (2006.01)  
 (72) Inventeurs/Inventors:  
ALHAUG, ESPEN, NO;  
MEINSETH, STEIN ERIK, NO  
 (73) Propriétaire/Owner:  
REELWELL AS, NO  
 (74) Agent: AVENTUM IP LAW LLP

(54) Titre : ACTIONNEUR POUR SOUPEPE DE DOUBLE TRAIN DE TIGES ET CONFIGURATION DE SOUPEPE  
ROTATIVE DE TRAINS DE TIGES POUR CELUI-CI  
 (54) Title: ACTUATOR FOR DUAL DRILL STRING VALVE AND ROTARY DRILL STRING VALVE CONFIGURATION  
THEREFOR



(57) **Abrégé/Abstract:**

A dual drill string valve includes an actuator (100) including a piston (114) disposed in a housing (110), which is configured to couple at its ends to an end of a nested dual drill string segment. An upper inner conduit (112) and a lower inner conduit (115) are

(57) **Abrégé(suite)/Abstract(continued):**

mounted in the housing, proximate to the longitudinal ends thereof. The piston is slidably, sealingly engaged between the upper and lower inner conduits and defines a fluid flow passage therethrough. The upper inner conduit, the piston and the lower inner conduit define another flow passage between respective exterior surfaces thereof and an interior of the housing such that application of fluid pressure to the external flow passage causes movement of the piston away from the upper inner conduit. A rotary valve is coupled to the actuator whereby longitudinal movement thereof rotates the rotary valve.

(12) INTERNATIONAL APPLICATION PUBLISHED UNDER THE PATENT COOPERATION TREATY (PCT)

(19) World Intellectual Property  
Organization  
International Bureau(10) International Publication Number  
**WO 2013/127610 A3**(43) International Publication Date  
6 September 2013 (06.09.2013)

- (51) **International Patent Classification:**  
E21B 21/10 (2006.01) E21B 21/12 (2006.01)
- (21) **International Application Number:**  
PCT/EP2013/052320
- (22) **International Filing Date:**  
6 February 2013 (06.02.2013)
- (25) **Filing Language:** English
- (26) **Publication Language:** English
- (30) **Priority Data:**  
13/406,979 28 February 2012 (28.02.2012) US
- (71) **Applicant:** REELWELL AS [NO/NO]; P.O. Box 22, N-4059 Roeyneberg (NO).
- (72) **Inventors:** ALHAUG, Espen; Vedeveien 33, N-4026 Stavanger (NO). MEINSETH, Stein Erik; Solandsbakken 65 B, N-4025 Stavanger (NO).
- (74) **Agents:** INTÈS, Didier et al.; Cabinet Beau De Lomenie, 158 Rue de l'Université, F-75340 Paris Cedex 07 (FR).

- (81) **Designated States** (*unless otherwise indicated, for every kind of national protection available*): AE, AG, AL, AM, AO, AT, AU, AZ, BA, BB, BG, BH, BN, BR, BW, BY, BZ, CA, CH, CL, CN, CO, CR, CU, CZ, DE, DK, DM, DO, DZ, EC, EE, EG, ES, FI, GB, GD, GE, GH, GM, GT, HN, HR, HU, ID, IL, IN, IS, JP, KE, KG, KM, KN, KP, KR, KZ, LA, LC, LK, LR, LS, LT, LU, LY, MA, MD, ME, MG, MK, MN, MW, MX, MY, MZ, NA, NG, NI, NO, NZ, OM, PA, PE, PG, PH, PL, PT, QA, RO, RS, RU, RW, SC, SD, SE, SG, SK, SL, SM, ST, SV, SY, TH, TJ, TM, TN, TR, TT, TZ, UA, UG, US, UZ, VC, VN, ZA, ZM, ZW.
- (84) **Designated States** (*unless otherwise indicated, for every kind of regional protection available*): ARIPO (BW, GH, GM, KE, LR, LS, MW, MZ, NA, RW, SD, SL, SZ, TZ, UG, ZM, ZW), Eurasian (AM, AZ, BY, KG, KZ, RU, TJ, TM), European (AL, AT, BE, BG, CH, CY, CZ, DE, DK, EE, ES, FI, FR, GB, GR, HR, HU, IE, IS, IT, LT, LU, LV, MC, MK, MT, NL, NO, PL, PT, RO, RS, SE, SI, SK, SM, TR), OAPI (BF, BJ, CF, CG, CI, CM, GA, GN, GQ, GW, ML, MR, NE, SN, TD, TG).

[Continued on next page]

(54) **Title:** ACTUATOR FOR DUAL DRILL STRING VALVE AND ROTARY DRILL STRING VALVE CONFIGURATION THEREFOR

FIG. 3A

(57) **Abstract:** A dual drill string valve includes an actuator (100) including a piston (114) disposed in a housing (110), which is configured to couple at its ends to an end of a nested dual drill string segment. An upper inner conduit (112) and a lower inner conduit (115) are mounted in the housing, proximate to the longitudinal ends thereof. The piston is slidably, sealingly engaged between the upper and lower inner conduits and defines a fluid flow passage therethrough. The upper inner conduit, the piston and the lower inner conduit define another flow passage between respective exterior surfaces thereof and an interior of the housing such that application of fluid pressure to the external flow passage causes movement of the piston away from the upper inner conduit. A rotary valve is coupled to the actuator whereby longitudinal movement thereof rotates the rotary valve.

WO 2013/127610 A3

**WO 2013/127610 A3**

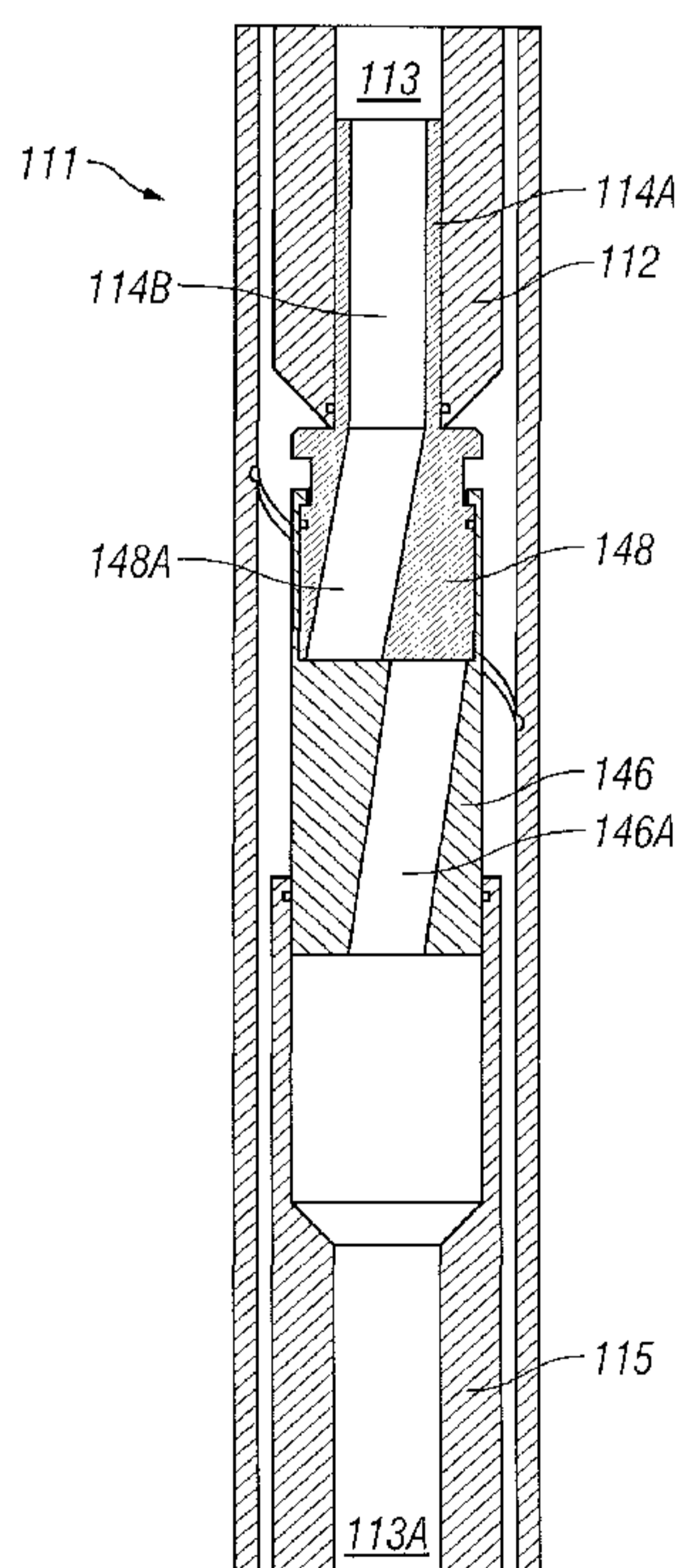

**Published:**

- *with international search report (Art. 21(3))*
- *before the expiration of the time limit for amending the claims and to be republished in the event of receipt of amendments (Rule 48.2(h))*

**(88) Date of publication of the international search report:**  
17 July 2014

# ACTUATOR FOR DUAL DRILL STRING VALVE AND ROTARY DRILL STRING VALVE CONFIGURATION THEREFOR

## FIELD

5 [0001] The invention relates generally to the field of dual drill pipe strings. More specifically, the invention relates to an actuator and a valve system and configurations of a valve system used with dual drill strings.

## BACKGROUND

[0002] It is known in the art of subsurface wellbore drilling to use a single pipe string,  
10 two parallel pipes or two nested or concentric pipe strings. Concentric or nested pipe strings refer to a string consisting of inner pipe joints arranged within outer pipe joints connected end to end.

[0003] In concentric or nested drill strings, the inner pipe forms part of a flow bore extending from the surface to a drill bit at the lower end of the drill string. An annulus  
15 between the outer pipe and inner pipe forms part of a second flow bore extending from the surface to the drill bit. Further, it is known to provide barriers or valves (e.g., check valves) in the pipe string to prevent gas-kicks, blow-outs etc. to move to the surface during drilling operations. Drilling operations may refer to the drilling of a wellbore, including the connection and disconnection of pipe segments (joints or multiple joint  
20 “stands”) during drilling operations. The barriers may be in the form of valves in the flow bores, arranged to provide seals against uncontrolled flow, such as gas-kicks and blow-outs. The valves may be check valves allowing flow in one direction and preventing flow in the other direction.

[0004] The term “drilling” as used herein should be understood to refer to creation of a  
25 hole in the subsurface by means of the pipe string. It particularly applies for drilling in the crust of the earth for petroleum recovery, tunnels, canals or for recovery of geothermal energy, both offshore and onshore.

[0005] U.S. Patent Application Publication No. 2010/0116501 A1 discloses a backup safety flow control system for concentric drill strings. The '501 publication shows a primary annulus shutoff valve assembly and a backup annulus shutoff valve assembly in the annular bore, and a primary inner bore shutoff valve assembly in the inner bore.

5 In addition, in case the primary inner bore shutoff valve assembly fails, the flow control system includes a backup inner bore shutoff valve by means of a valve that may be dropped from the surface through the inner bore. When the wellbore pressure is brought under control, the drill string can be removed from the well so that the backup inner shutoff valve may be removed.

10 [0006] What is needed is a valve system for use with dual drill strings that can provide a backup flow control.

### SUMMARY

[0007] A dual drill string valve includes an actuator including a piston disposed in a housing. The housing is configured to sealingly couple at its longitudinal ends to an end  
15 of a nested dual drill string segment. An upper internal conduit is mounted in the housing proximate one longitudinal end thereof. A lower internal conduit is mounted in the housing proximate the other longitudinal end thereof. The piston is slidably, sealingly engaged between the upper and lower inner conduits and defines an internal fluid flow passage therethrough. The upper inner conduit, the piston and the lower  
20 inner conduit define an external flow passage between respective exterior surfaces thereof and an interior of the housing such that application of fluid pressure to the external flow passage causes movement of the piston away from the upper inner conduit. A rotary valve is coupled to the actuator such that movement of the piston longitudinally causes rotation of the rotary valve.

25 [0008] In one or more embodiments, the dual drill string valve further includes a biasing device arranged to urge the piston to move toward the upper inner conduit.

[0009] In one or more embodiments, the biasing device comprises a spring.

[0010] In one or more embodiments, the rotary valve comprises a valve seat disposed proximate one end of the upper inner conduit and a seal seat disposed on a portion of  
30 the piston that is slidably engaged with an interior of the upper inner conduit, wherein

movement of the piston toward the upper inner conduit closes an internal flow passage to fluid flow.

[0011] In one or more embodiments, the piston comprises a tube slidably, sealingly engaged with a rotatable valve disc, where the rotatable valve disc is engaged with a rotationally fixed valve plunger, and means for rotating the rotatable valve disc upon longitudinal motion thereof. Each of the rotatable valve disc and the rotationally fixed valve plunger comprises an offset flow passage, where the offset flow passages are configured to make fluid connection therebetween when the rotatable valve disc is in one rotational position and to stop fluid connection therebetween when the rotatable valve disc is in a different rotational position.

[0012] In one or more embodiments, the dual drill string valve further comprises a seal seat on an upper, outer portion of the rotatable valve disc and a corresponding valve seat disposed on a lower end of the upper inner conduit such that movement of the tube, the rotatable valve disc, and the rotationally fixed plunger toward the upper inner conduit closes a passage to flow defined between an interior of the housing and the exterior of the upper inner conduit, the tube, the rotatable valve disc, the rotationally fixed plunger, and the lower inner conduit.

[0013] Other aspects and advantages of the invention will be apparent from the description and claims which follow.

## BRIEF DESCRIPTION OF THE DRAWINGS

[0014] FIG. 1 shows an example drilling arrangement using a nested or concentric drill pipe string and drill string valves.

[0015] FIGS. 2A and 2B show cut away views of a dual drill string actuator, in the closed and open position, respectively

[0016] FIGS. 3A and 3B show an example dual drill string rotary valve in the open (activated) position and closed position, respectively.

[0017] FIGS. 4A and 4B show an example dual drill string rotary valve in the open (activated) position and closed position, respectively.

### DETAILED DESCRIPTION

[0018] In FIG. 1 a nested or concentric dual drill string 1 is shown inserted in a wellbore 17 being drilled through subsurface formations 33. The wall of the wellbore 17 creates an annular space (well annulus 9) between the exterior of the dual drill string 1 and the wall of the wellbore 17. The dual drill string 1 may comprise a dual bore drill pipe consisting of an inner pipe 3 arranged within an outer pipe 2. A supply flow of drilling fluid (e.g., “drilling mud”), shown at A, is introduced through a suitable swivel 24 such as a top drive into an annular bore (“fluid supply flow passage”) 4 disposed between the inner pipe 3 and the outer pipe 2. The supply flow of drilling fluid A may be ultimately directed to a drill bit 7 that cuts the formations 33. A return flow of drilling fluid, shown at B is transported from the bottom of the wellbore 17 in an inner bore (“return fluid passage”) 5 within the inner pipe 3.

[0019] In the example shown in FIG. 1, the dual drill string 1 may be arranged with a piston 20 fixed to the dual drill string 1 and in sealing contact with the wall of the wellbore 17. The top drive 24 may also rotate or drive the dual drill string 1. A blow out preventer (BOP) 22 and a rotating control device (RCD) 23 may be arranged at the top of the wellbore 17. By the arrangement of the RCD 23 and piston 20, an isolated space is provided in the upper part of the wellbore 17. In the present example, a fluid may be introduced through a fluid inlet 21 into the isolated space. The introduced fluid provides a pressure to the piston 20, thereby forcing the piston 20 and the dual drill string 1 downwards when drilling is performed. As will be appreciated by those skilled in the art, other arrangements than the piston 20 shown in FIG. 1 may be used for providing a driving force to the dual drill string 1, or may be omitted, wherein the isolated space in the wellbore annulus 9 is closed by the BOP 22 and RCD 23. Thus, the use of the piston 20 in the wellbore annulus 9 is not a limitation on the scope of the invention.

[0020] The dual drill string 1 is typically arranged with a flow diverter 6 at a lower end thereof connected to a bottom hole assembly (BHA) 8 holding the bit 7 at a lower end portion of the drill string. The bottom hole assembly (BHA) 8 may a standard type BHA that can be used with conventional (single flow bore) drill pipe and drilling tools, including, without limitation, hydraulic (mud) motors, drill collars, measurement

and/or logging while drilling tools. The BHA may also be a reverse flow type such as used in air drilling mining operations. The flow diverter 6 has a flow passage assembly 10a providing a fluid connection between the fluid supply flow passage 4 of the dual drill string 1 and a channel 14 or channel assembly of the BHA 8. The channel 14 of the BHA 8 is shown in the example of FIG. 1 with the shape of an axial bore, and the flow passage assembly 10a is shown with essentially a Y-shape in an axial cross section. First diverging branches 30 of the Y fit in connection with the fluid supply flow passage 4, and an axial passage part 31 corresponds to the stem portion of the Y and fits in connection with the axial shaped channel 14 of the BHA. The supply flow A exits from the channel 14 into the BHA 8 and thence into the cutting area of the drill bit 7.

[0021] From the drill bit 7, the return fluid flow B moves in the well annulus 9 into a return flow passage assembly 10b arranged in the flow diverter 6. The axial cross section of a return flow passage assembly 10b also has a Y shape with second diverging branches 41 opening at one end into the well annulus 9 and an axial passage part 40 connected with the fluid return flow passage 5. The return flow B enters the inlet of the flow diverter return flow passage 10b and returns in the fluid return flow passage 5 of the dual string 1.

[0022] The dual drill string 1 may be arranged, for example, with a selected number of valve elements (four shown in the present example), although the number of such valves and their placement within the drill string is not intended to limit the scope of the invention. Two of the valve elements may be arranged for closing and opening of the fluid supply flow A, and two of the valve elements may be arranged for closing and opening of the fluid return flow B. By such arrangement of valve elements, a double barrier system may be provided both for the control of the fluid supply flow A and for control of the fluid return flow B. The closing of the valve elements may be performed, in some examples automatically if the drilling system needs to close down, and in case of emergency, for example, a kick or other unwanted well fluid control conditions. Other examples of valve elements, to be described in more detail below, may close both the fluid supply flow passage 4 and the return fluid passage 5.

[0023] In FIG. 1 example locations of the four valve elements are shown schematically. Two bottom valves 11c, 11d provided for opening and closing the supply

flow A, may be located in the bottom hole assembly 8. The bottom valves 11c, 11d may be positioned to open and close the channel 14, and one of the bottom valves, e.g., 11c, may be positioned to control the opening and closing of the outlet 15 of the channel 14. The other bottom valve 11d may be positioned upstream along the channel 14 within  
5 the bottom hole assembly 8. The bottom valves 11c, 11d may be conventional drill string check valves as are used with single bore drill string components. Upper valves 11a, 11b may be positioned in the dual drill string 1. The upper valves 11a, 11b, may be specifically configured to connect within a nested dual drill string, for example, one shown in U.S. Patent No. 3,208,539 issued to Henderson, and the valves 11a, 11b may  
10 be referred to hereinafter for convenience as dual drill string valves.

[0024] The dual drill string actuators and associated valves 11a, 11b may be better understood with reference to FIGS. 2A, 2B, 3A, 3B and 4A, 4B. An important component of a dual drill string valve according to the invention, and referring to FIGS. 2A and 2B, is a dual drill string compatible valve actuator 100. Referring to FIG. 2A,  
15 an example dual drill string actuator 100 may be enclosed in a housing 110 that may have connections (not shown separately) at each longitudinal end for engaging the housing 110 to a segment of the dual drill string, e.g., 1 in FIG. 1) on one or both longitudinal ends thereof. "Engagement" may include metal to metal or other form of sealing between the housing 110 and each connected segment of the outer pipe, as  
20 explained with reference to FIG. 1. "Engagement" may further include having an upper internal conduit 112 mounted in fixed longitudinal position within the housing 110. Such mounting may include, without limitation, friction fit standoffs, welding, adhesive bonding, etc. The upper inner conduit 112 may be configured to sealingly engage the inner pipe (3 in FIG. 1) to enable completion of the fluid return flow passage (5 in FIG.  
25 1) through the actuator 100. A fluid return flow passage formed by the components of the actuator 100 is shown generally at 113 and 113A. As will be further explained below, the actuator 100 also may provide a fluid flow passage between the interior of the housing 110 and the exterior of the upper internal conduit 112, lower internal conduit 115 and additional components explained below. Thus, the actuator 100 may  
30 be configured so that its behavior with respect to the dual drill string (1 in FIG. 1) is essentially "transparent", that is, the drilling rig operator or user may handle the

actuator 100 in essentially the same manner as any other segment of the dual drill string (1 in FIG. 1).

[0025] In the present example, a piston 114 may be disposed inside the housing 110 and may include at one longitudinal end a tube 114A that may slidably engage with an interior bore of the upper inner conduit 112. The tube 114A may be sealed to the upper inner conduit 112 using seals D1 of any type known in the art enabling longitudinal motion while maintaining a pressure tight seal, e.g., o-rings or the like. The lower inner conduit 115 may be mounted in the housing 110 at the opposite longitudinal end of the housing 110. The lower inner conduit 115 may be configured at its longitudinal end to sealingly engage another segment of dual drill string such as shown in FIG. 1. The lower inner conduit 115 may be mounted inside the housing 110 in any manner as explained with reference to the upper inner conduit 112. The piston 114 may also slidably engage the lower inner conduit 115. Such sliding engagement may include pressure tight sealing, for example, by using o-rings or similar seals such as shown at D2. Thus, the piston 114 may move longitudinally with respect to the upper 112 and lower 115 inner conduits while maintaining a sealed inner fluid passage, shown by the combination of elements 113, 114B and 113A. In the example shown in FIGS. 2A and 2B, a spring or biasing device 116 may urge the piston 114 into its raised position (FIG. 2A) in the absence of any fluid flow through the actuator 100.

[0026] The mounting of both the upper inner conduit 112 and the lower inner conduit 115 within the housing 110 may be configured to enable fluid flow in a passage formed between the interior wall of the housing 110 and the exterior of the upper inner conduit 112, the piston 114 and the lower inner conduit 115. Thus, the actuator 100 may be substantially transparent with respect to the dual drill string as it concerns fluid flow therethrough; there is provided by the described structure both an inner flow passage and an outer flow passage corresponding to such passages in the dual drill string (1 in FIG. 1).

[0027] Specifically referring to FIG. 2A, the actuator 100 is shown in its state that exists when the fluid supply flow (A in FIG. 1) is stopped. The BHA 8 is shown schematically at a position below the actuator 100. The BHA 8 may include a conventional float or check valve, shown at 8A, and the lower part of the BHA 8, which

may include a “mud” drilling motor (not shown) and the drill bit (7 in FIG. 1) is shown schematically at 8B as a resistance to flow therethrough. In FIG. 2A, the piston 114 is in its uppermost position. Referring to FIG. 3A, when the fluid supply flow (A in FIG. 1) is turned on, pressure P1 will exist in the passage between the interior wall of the housing 110 and the exterior of the upper inner conduit 112, the piston 114 and the lower interior conduit 115. Because of the resistance to flow provided by the BHA 8, the pressure P1 will typically be greater than the pressure below the actuator 100, shown by P2. The pressure P1 acts on the piston 114 to move it downwardly, as shown in FIG. 2B. The float valve 8A is shown open in FIG. 2B, which results from flow leaving the actuator 100.

[0028] The actuator 100 shown in and explained with reference to FIGS. 2A and 2B may be used in conjunction with any other apparatus disposable in a drill string. For such use, it is only necessary to provide connection such that motion of the piston 114 causes operation of another device.

[0029] It will be appreciated that the flow diverter (6 in FIG. 1) and other detailed components of the BHA 8 have been omitted from FIGS. 2A and 2B for simplicity of the illustration. In actual drilling use, such components may be included in the dual drill string as required, for example, as shown in FIG. 1.

[0030] Referring to FIGS. 3A and 3B, one example of a drill string valve associated with the above described actuator will be explained. A drill string valve 111 using the actuator of FIGS. 2A and 2B may be formed by including within the piston structure (FIGS 2A and 2B) a rotary valve. The rotary valve may be assembled from separate components, explained below, to form the piston (114 in FIGS. 2A and 2B), such that application of supply fluid flow (A in FIG. 1) will cause downward motion of the rotary valve, thereby causing it to open.

[0031] In the present example, the rotary valve may include a tube 114A that sealingly, slidably engages the upper inner conduit 112, as in the actuator shown in FIGS. 2A and 2B. The tube 114A may be sealed to the interior of the upper inner conduit 112 using seals, D1 in FIG. 2B. The tube 114A may be affixed at its lower end to a rotatable valve disc 148. The rotatable valve disc 148 may include an internal passage 148A that is aligned with the passage 114B in the tube 114 where the tube 114

and rotatable valve disc 148 contact each other, and is laterally displaced at the lower end of the rotatable valve disc 148. The rotatable valve disc 148 may contact at its lower end a rotationally fixed valve plunger 146. The rotationally fixed valve plunger 146 may include a corresponding passage 146A (FIG. 3B) therein to provide fluid communication with passage 113A in the lower inner conduit 115. A helical guide 140 may be formed in the interior of the housing 110, for example, as a groove or as a ridge. A groove may provide easier assembly and disassembly of the valve 111, however this is not a limitation on the scope of the invention. A mating pin or groove, shown at 141, may be provided on the tube 114 or the rotatable valve disc 148.

10 [0032] When the fluid supply flow (A in FIG. 1) is turned on, and pressure P1 exists in the interior of the housing, but outside the tube 114, rotatable valve disc 148 and rotationally fixed valve plunger 146, the entire assembly of the foregoing components is urged downward by the differential pressure, essentially as explained with reference to the actuator described above. In the present example, however, engagement of the pin 15 141 with the groove 140 causes rotation of the rotatable valve disc 148. In the "closed" position shown in FIG. 3A, the passages 148A, 146A are misaligned, and the rotary valve is closed to flow. In FIG. 3B, when the foregoing assembly of components is moved downwardly by pressure P1, the rotatable valve disc 148 rotates so that the passages 148A, 146A are aligned to enable flow therethrough. Thus, the interior passage of the valve 111, consisting of upper inner conduit passage 113, tube passage 20 114B, valve disc/plunger passages 148A, 146A and lower inner conduit passage 113A form an open passage to fluid flow. In this way, when the fluid supply flow (A in FIG. 1) is stopped, the passage just described will close, thereby stopping flow from the well into the fluid return flow (B in FIG. 1) part of the dual drill string (e.g., 5 in FIG. 1). Fluid flow into the fluid supply flow part of the dual drill string (e.g., 4 in FIG. 1) may be stopped by the float valve (8A in FIG. 2A).

[0033] A spring, such as shown at 116 in FIGS. 2A and 2B may be used in cooperation with the rotationally fixed valve plunger 146 to assist in closing the valve, substantially as explained with reference to FIGS. 2A and 2B.

30 [0034] An alternative valve 111 may be better understood with reference to FIGS. 4A and 4B. The valve 111 shown in FIGS. 4A (closed position) and FIG. 4B (open position)

may include substantially all the components of the rotary valve shown in FIGS. 3A and 3B, with the addition of a valve seat 137A that cooperatively engages a seal seat 137 when the rotary valve components are in the position shown in FIG. 4A. Thus, a fluid flow passage formed inside the housing 110, but outside the upper inner conduit 112, tube 114, rotatable valve disc 148, rotationally fixed valve plunger 146 and lower inner conduit 115 will be closed to flow when the fluid supply flow (A in FIG. 1) is turned off.

[0035] Two or more of the valves shown in FIGS. 4A and 4B may be placed at selected longitudinal positions (e.g., as shown in FIG. 1) to provide additional wellbore pressure control.

[0036] Dual drill string valves according to the various aspects of the invention may provide better control over wellbore pressure and may be used more flexibly and in greater numbers of combinations than drill string valves known in the art prior to the present invention.

[0037] While the invention has been described with respect to a limited number of embodiments, those skilled in the art, having benefit of this disclosure, will appreciate that other embodiments can be devised which do not depart from the scope of the invention as disclosed herein. Accordingly, the scope of the invention should be limited only by the attached claims.

CLAIMS

1. A dual drill string valve, comprising:  
an actuator (100) comprising;  
a piston (114) disposed in a housing (110), the housing (110) configured to  
5 sealingly couple at its longitudinal ends to an end of a nested dual drill  
string segment,  
an upper inner conduit (112) mounted in the housing (110) proximate one  
longitudinal end thereof,  
a lower internal conduit (115) mounted in the housing (110) proximate the  
10 other longitudinal end thereof, the piston (114) slidably, sealingly  
engaged between the upper (112) and lower (115) inner conduits and  
defining an internal fluid flow passage therethrough, and  
wherein the upper inner conduit (112), the piston (114) and the lower inner  
conduit (115) define an external flow passage between respective  
15 exterior surfaces thereof and an interior of the housing such that  
application of fluid pressure to the external flow passage causes  
movement of the piston away from the upper inner conduit; and  
a rotary valve coupled to the actuator (100) such that movement of the piston  
(114) longitudinally causes rotation of the rotary valve.
- 20 2. The dual drill string valve of claim 1 further comprising a biasing device  
(116) arranged to urge the piston (114) to move toward the upper inner  
conduit (112).
3. The dual drill string valve of claim 2 wherein the biasing device (116)  
comprises a spring.
- 25 4. The dual drill string valve of claim 1 wherein the rotary valve comprises a  
valve seat (137A) disposed proximate one end of the upper inner conduit  
(112) and a seal seat (137) disposed on a portion of the piston (114) slidably  
engaged with an interior of the upper inner conduit (112), wherein movement

of the piston (114) toward the upper inner conduit (112) closes an internal flow passage to fluid flow.

5. The dual drill string valve of claim 1 wherein the piston (114) comprises a tube (114A) slidably, sealingly engaged with a rotatable valve disc (148), the rotatable valve disc (148) engaged with a rotationally fixed valve plunger (146), means for rotating the rotatable valve disc (148) upon longitudinal motion thereof, and wherein each of the rotatable valve disc (148) and the rotationally fixed valve plunger (146) comprises an offset flow passage (148A, 146A), the offset passages (148A, 146A) configured to make fluid connection therebetween when the rotatable valve disc (148) is in one rotational position and to stop fluid connection therebetween when the rotatable valve disc (148) is in a different rotational position.
6. The dual drill string valve of claim 5 further comprising a seal seat (137) on an upper, outer portion of the rotatable valve disc (148) and a corresponding valve seat (137A) disposed on a lower end of the upper inner conduit (112) such that movement of the tube (114A), the rotatable valve disc (148) and the rotationally fixed plunger (146) toward the upper inner conduit (112) closes a passage to flow defined between an interior of the housing (110) and the exterior of the upper inner conduit (112), the tube (114A), the rotatable valve disc (148), the rotationally fixed plunger (146), and the lower inner conduit (115).



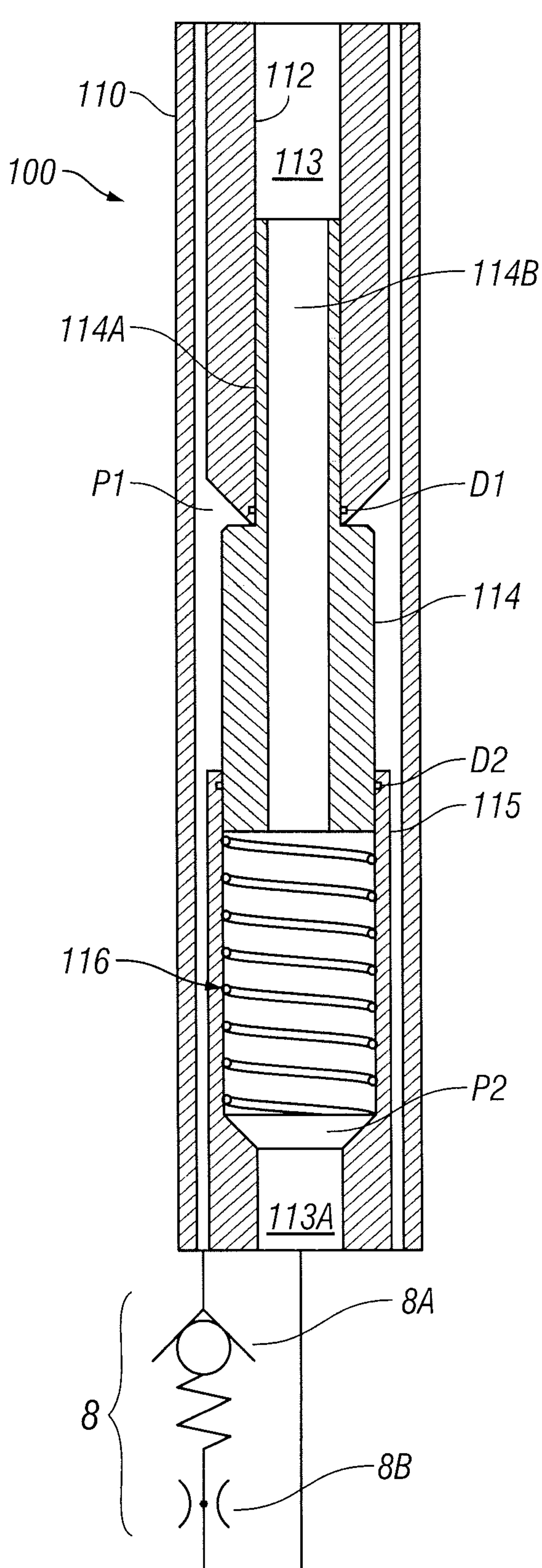

FIG. 2A

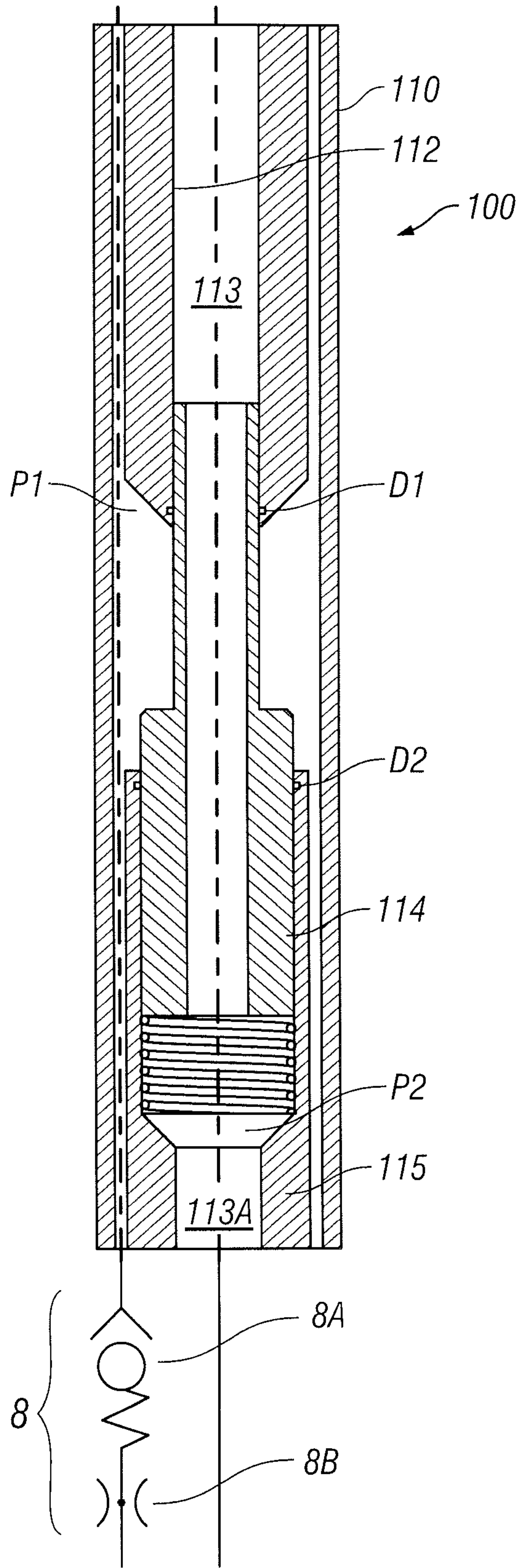

FIG. 2B

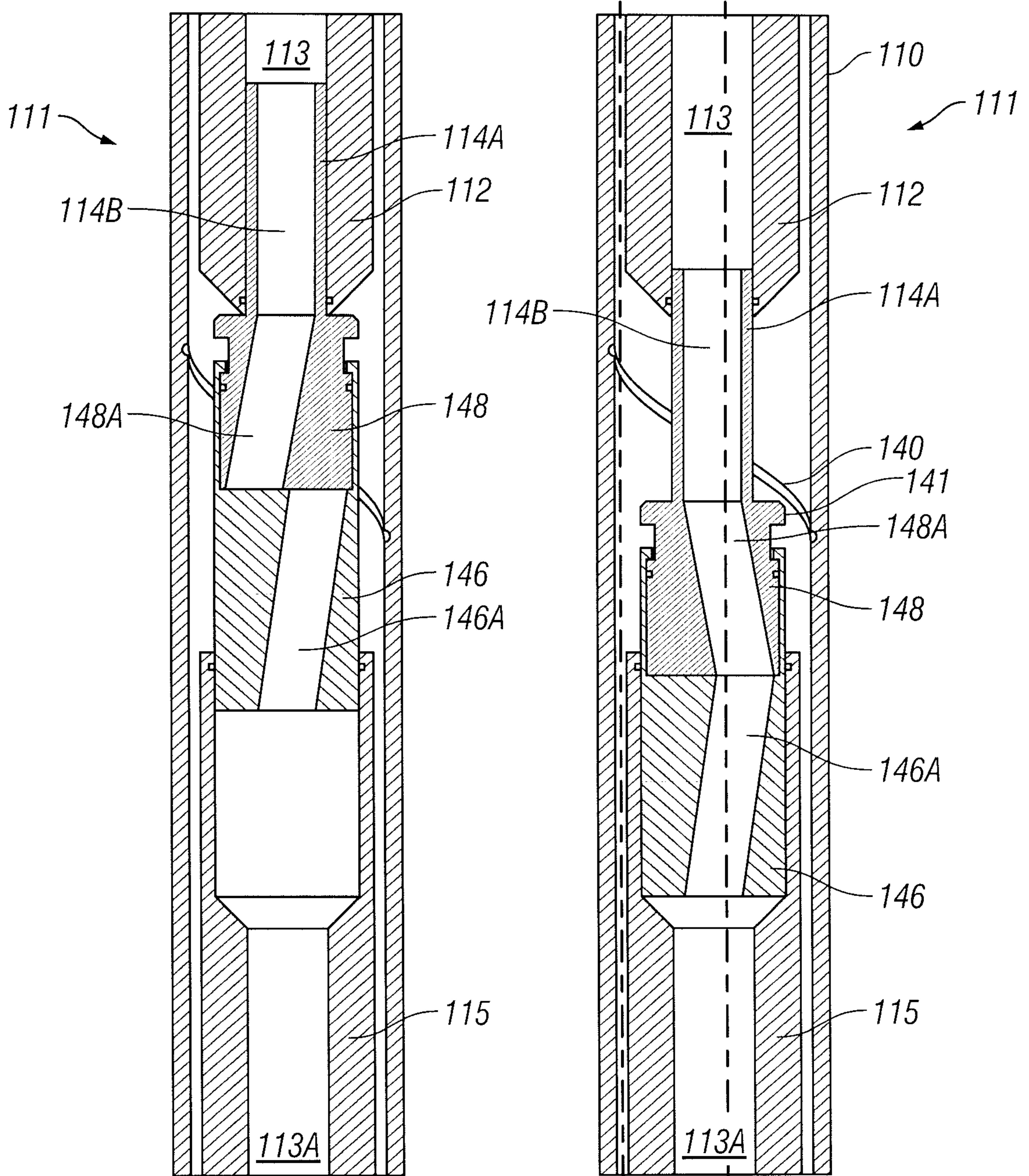

FIG. 3A

FIG. 3B

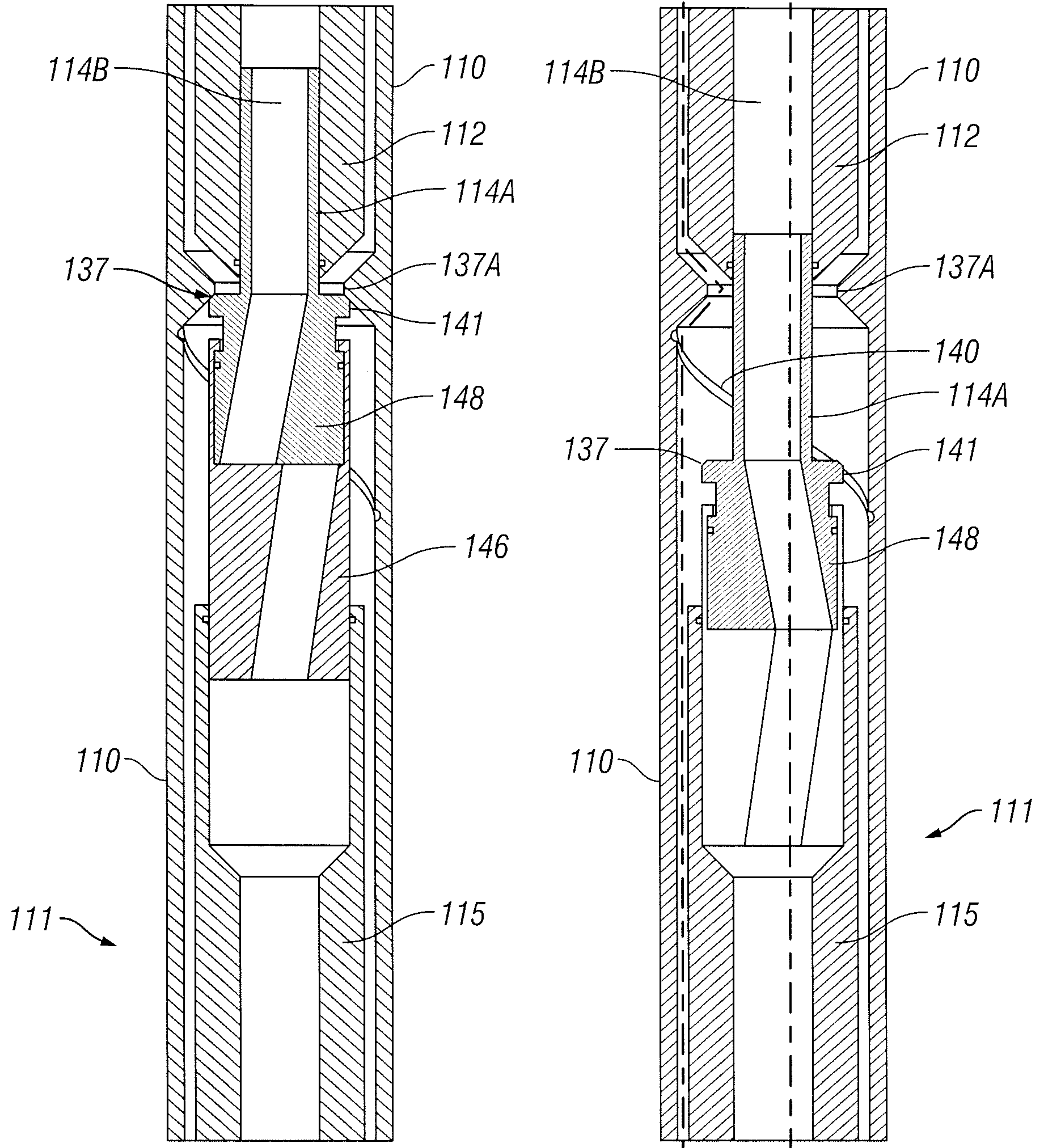

FIG. 4A

FIG. 4B

