



## INTERNATIONAL APPLICATION PUBLISHED UNDER THE PATENT COOPERATION TREATY (PCT)

<p>(51) International Patent Classification<sup>6</sup> : A61K 41/00, A61N 2/02, 2/00</p>	<p>A1</p>	<p>(11) International Publication Number: <b>WO 00/02585</b></p> <p>(43) International Publication Date: 20 January 2000 (20.01.00)</p>
<p>(21) International Application Number: PCT/US98/22135</p> <p>(22) International Filing Date: 20 October 1998 (20.10.98)</p> <p>(30) Priority Data: 09/111,769 8 July 1998 (08.07.98) US</p> <p>(71) Applicant: EMF THERAPEUTICS, INC. [US/US]; P.O. Box 679, Signal Mountain, TN 37377 (US).</p> <p>(72) Inventors: WASCHER, Rick, R.; P.O. Box 7295, McMinnville, TN 37111 (US). WILLIAMS, C., Douglas; P.O. Box 679, Signal Mountain, TN 37377 (US). BOULDIN, Floyd, E.; 111 Laws Road, McMinnville, TN 37110 (US).</p> <p>(74) Agent: WASCHER, Rick, R.; EMF Therapeutics, Inc., 111 Laws Road, McMinnville, TN 37110 (US).</p>		<p>(81) Designated States: AU, BG, CA, CN, HU, IL, JP, KP, KR, MN, MX, NO, NZ, PL, RO, TR, UA, VN, Eurasian patent (AM, AZ, BY, KG, KZ, MD, RU, TJ, TM), European patent (AT, BE, CH, CY, DE, DK, ES, FI, FR, GB, GR, IE, IT, LU, MC, NL, PT, SE).</p> <p><b>Published</b> <i>With international search report.</i> <i>With amended claims and statement.</i></p>
<p>(54) Title: RETARDING TUMOR ANGIOGENESIS RELATED GROWTH</p>		
<p>(57) Abstract</p> <p>A magnetic field device and method for inhibiting angiogenesis and retarding growth rates of cancerous tumors present in mammals. The apparatus includes a frame, and a wire consisting of electrically conducting material. The wire is wrapped around the frame to form a coil. A source of AC current is connected to a transformer to vary the AC voltage. The AC current is passed through a bridge rectifier and then to the coil of wire enabling a DC rectified wave magnetic field to be produced therefrom. The method employs the use of an apparatus which is capable of producing a magnetic field of a particular nature which has been proven in animal studies to affect angiogenesis and retard the growth rate of cancerous tumors.</p>		

**FOR THE PURPOSES OF INFORMATION ONLY**

Codes used to identify States party to the PCT on the front pages of pamphlets publishing international applications under the PCT.

AL	Albania	ES	Spain	LS	Lesotho	SI	Slovenia
AM	Armenia	FI	Finland	LT	Lithuania	SK	Slovakia
AT	Austria	FR	France	LU	Luxembourg	SN	Senegal
AU	Australia	GA	Gabon	LV	Latvia	SZ	Swaziland
AZ	Azerbaijan	GB	United Kingdom	MC	Monaco	TD	Chad
BA	Bosnia and Herzegovina	GE	Georgia	MD	Republic of Moldova	TG	Togo
BB	Barbados	GH	Ghana	MG	Madagascar	TJ	Tajikistan
BE	Belgium	GN	Guinea	MK	The former Yugoslav Republic of Macedonia	TM	Turkmenistan
BF	Burkina Faso	GR	Greece			TR	Turkey
BG	Bulgaria	HU	Hungary	ML	Mali	TT	Trinidad and Tobago
BJ	Benin	IE	Ireland	MN	Mongolia	UA	Ukraine
BR	Brazil	IL	Israel	MR	Mauritania	UG	Uganda
BY	Belarus	IS	Iceland	MW	Malawi	US	United States of America
CA	Canada	IT	Italy	MX	Mexico	UZ	Uzbekistan
CF	Central African Republic	JP	Japan	NE	Niger	VN	Viet Nam
CG	Congo	KE	Kenya	NL	Netherlands	YU	Yugoslavia
CH	Switzerland	KG	Kyrgyzstan	NO	Norway	ZW	Zimbabwe
CI	Côte d'Ivoire	KP	Democratic People's Republic of Korea	NZ	New Zealand		
CM	Cameroon			PL	Poland		
CN	China	KR	Republic of Korea	PT	Portugal		
CU	Cuba	KZ	Kazakstan	RO	Romania		
CZ	Czech Republic	LC	Saint Lucia	RU	Russian Federation		
DE	Germany	LI	Liechtenstein	SD	Sudan		
DK	Denmark	LK	Sri Lanka	SE	Sweden		
EE	Estonia	LR	Liberia	SG	Singapore		

## RETARDING TUMOR ANGIOGENESIS RELATED GROWTH

### Technical Field

“Angiogenesis” may be defined as the formation or the initiation of blood carrying vessel or capillary growth in a biological subjects, particularly mammals.

The present invention is directed to a device and/or the use thereof wherein the device is capable of producing a magnetic flux field found useful to inhibit angiogenesis in mammals. It is believed that the present invention was universally unknown to mankind prior to the time it became known the inventors hereof.

### Background Art

In mature (non-growing) capillaries the vessel wall is composed of an endothelial cell lining, a basement membrane, and a layer of cells called pericytes which partially surround the endothelium. The pericytes are contained within the same basement membrane as the endothelial cells and occasionally make direct contact with them. (See Background Figure A).

With reference to Background Art Figure B, angiogenic factors (the black triangles) bind to endothelial cell receptors and initiate the sequence of angiogenesis. When the endothelial cells are stimulated to grow, they secrete proteases which digest the basement membrane surrounding the vessel. The junctions between endothelial cells are altered allowing cell projections to pass through the space created and the newly formed sprout grows towards the source of the stimulus.

With reference to Background Art Figure C, continued capillary sprout growth is dependent upon several processes and factors: (i) the stimulus for growth must be maintained; (ii) the endothelial cells must secrete the proteases required to break down the adjacent tissue; (iii) the cells themselves must be capable of movement/migration; and (iv) endothelial cell division must take place to provide the necessary number of cells (this takes place at a site behind the growth front of the sprout). Neighboring blind-ended sprouts then join together to form a capillary loop which later matures into a vessel like the one from which it arose.

The following list of angiogenic related dependent diseases is not exhaustive, but does include the following: Angiofibroma which is an abnormal formation of blood vessels which are prone to bleeding; Neovascular Glaucoma which is an abnormal growth of blood vessels in the eye; Arteriovenous malformations which is an abnormal communication between arteries and veins; Nonunion fractures which are fractures that will not heal; Lupus, and other Connective Tissue Disorders; Osler-Weber syndrome which is a genetic condition resulting in abnormal blood vessels

which are prone to bleeding; Atherosclerotic plaques which is a hardening of the arteries; Psoriasis which is a common chronic skin condition; Corneal graft neovascularization which is a complication of corneal replacement surgery; Pyogenic granuloma which is a common skin lesion composed of blood vessels; Delayed wound healing; Diabetic retinopathy which is a leading cause of blindness in diabetics; Scleroderma which is a form of connective tissue disease; Granulations (burns); Neoplasm which is an abnormal cell growth forming solid tumors; Hemangioma which is a tumor composed of blood vessels; Trachoma which is a leading cause of blindness in some countries; Hypertrophic Scars which is abnormal scar formation; Retrolental fibroplasia which is abnormal growth of blood vessels in the retina; Hemophilic joints which is bleeding joints; Vascular adhesions which is excessive scarring; osteoarthritis and rheumatoid arthritis; macular degeneration; cancerous tumors generally; and pain.

Magnetism is a property of charge in motion and is related to electrical theory. As set forth in the examples, the target is mammalian tissue. A magnetic field surrounds a conductor through which current travels according to the well known "right hand rule". It is also known that a magnetic field of flux can induce current flow in circuits.

Until now, an apparatus and method of the type herein described capable of producing magnetic fields useful for inhibiting angiogenesis in biological subjects such as mammals was previously unknown and had not been discovered or invented.

Until now, an apparatus and method of the type herein described capable of producing magnetic fields useful for inhibiting angiogenesis and retarding the growth rates of cancerous tumors in biological subjects such as mammals was previously unknown and had not been discovered or invented.

Tumors cannot thrive without sufficient nutrition provided by the increased circulation of blood achieved through angiogenesis. Improved wound healing may also be explained by a reduction in angiogenesis. In the wound healing process, excessive angiogenesis is believed to lead to scar formation and inefficient (and thereby slower) healing. Pharmaceutical anti-angiogenic agents have reportedly improved wound healing by limiting angiogenic activity and avoiding pathologic angiogenesis. Pathologic angiogenesis is also present in such diseases as arthritis and autoimmune diseases (such as lupus and colitis). Therefore, it is currently believed that the common effects of an magnetic field are derived by modulating the effects of transforming growth factor beta (TGFb) alone or in combination with some other cellular or ionic effect.

TGFb is involved in a number of physiological processes, including cell growth and differentiation, embryonic development, extracellular matrix formation, bone remodeling, wound

healing, immune function, and angiogenesis. It is further believed that an increased expression of TGFb may mediate such activities as autoimmune disease. In addition, increased serum expression of TGFb has been shown to relieve rheumatoid arthritis symptoms.

5 The regulation of TGFb by the magnetic field of the present invention is explained by its varied effects of the field. It is unknown for certain, but it is believed that this regulation involves the expression of TGFb, either by itself or through the receptors for TGFb located on various target cells. Because of the magnetic and electrical elements of the field produced by the present invention and its application to a biological system, it is further believed that the receptors for TGFb provide the motive messaging to the target cells to affect TGFb. For example, the field could cause the cell  
10 to perform as though is had bound to TGFb by activating the TGFb receptors (especially the TGFb receptor 2).

Many sources cite TGFb as a protagonist of angiogenesis. Although increased expression of TGFb may be present in many cases of angiogenesis, others have shown that TGFb actually inhibits angiogenesis in microvascular endothelial cells. This effect seems to be directly linked to the activity  
15 of the TGFb receptor 2 (TGFb R2). When TGFb R2 is present and active at a ratio of approximately 5:1 with respect to the TGFb R1, proliferation of endothelial cells is inhibited. The TGFb R2 receptors are necessary to allow activation of the TGFb R1 receptor with its resulting phosphorylation cascade. The TGFb receptors are believed to be present on cell surfaces at all times, but are activated or made dormant by signals in the extracellular matrix. The expression of the  
20 magnetic field of the present invention on the extracellular matrix likely activates TGFb R2 sites to allow a phosphorylation cascade which inhibits angiogenesis.

### **Disclosure of Invention**

25 A magnetic field produced solely by a current carrying coil can be said to constitute an electromagnetic field for purposes of this discussion. The invention and its various embodiments partially comprise a current carrying wire for producing a magnetic field around the wire in accordance with the well known "right hand rule" (i.e., clockwise or counterclockwise around the wire, depending upon the direction of the current flow, when viewed from a hypothetical common cross-sectional face.).

30 The preferred embodiments of the present invention is/are directed to a device for establishing or otherwise creating a substantially contained field of magnetic flux energy which have been found particularly useful for affecting angiogenesis and retarding the growth rates of cancerous tumors in mammals such as laboratory mice. The preferred embodiment is a coil of conductor, for example

copper wire, with a voltage drop across its opposing ends wherein the affect on angiogenesis and retardation of tumor growth has been observed to be statistically significant, as verified by independent laboratory research tests.

The electromagnetic field of the preferred embodiment of the present invention has major components carrying frequency harmonics of 60 hertz (i.e., frequencies at 60 Hz, 120 Hz, 240 Hz, 480 Hz, etc.). Studies have shown that the TGFb receptor reacts as though it is bound to the TGFb protein at frequencies of approximately 120 Hz. In other words, the presence of a field and its induced current at a frequency of 120 Hz is believed to cause the TGFb receptor to act as though it had been bound by TGFb. This effect would cause the same result in a biological system as an infusion or increased expression of TGFb. This frequency response, induced by the field produced by the present invention, is believed to be associated with the field's strong frequency expression at 120 Hz and its harmonics and sub-harmonics.

For example, at a magnetic flux field amplitude of approximately 15-17 mT (the recommended therapeutic amplitude) the induced voltage of approximately one to ten millivolts has a current of approximately 10 milliamps in a subject exposed to the field. This voltage and amperage have been found to be sufficient to induce a biological effect in the subject.

In addition, an effect on either the expression or reception of an angiogenic growth factor such as vascular endothelial growth factor (VEGF) or basic fibroblast growth factor (bFGF) would help explain the robust effect achieved by the field of the present invention in inhibiting angiogenesis. Based on the apparently delayed field effect on angiogenesis, the field of the present invention is also believed to affect the expression or reception of bFGF since bFGF is generally present in the later stages of tumor development.

An alternate embodiment of the apparatus portion of the present invention and discovery includes a plurality of permanent magnets which are positioned about the periphery of a geometric frame in the form of a circle, rectangle, square or other shape such as the preferred ellipsoidal shape having a central opening. The preferred embodiment of the frame resembles an ellipsoidal shape comprised of multiple arc length segments ellipse but it is not a true ellipse, even though the deviation from a true ellipse might not be detectable to the human eye.

The preferred embodiment of the present invention comprises a tightly wound coil of continuous wire wrapped about the aforementioned non-conductive frame, which is preferably made of phenolic resin impregnated spun glass fibers. A current is passed through the coil in one of two directions "+" positive or "--" negative, (i.e., voltage drop to the right or to the left). The current carrying coil produces a magnetic field.

The number of coil wire turns may vary. Various embodiments of the present inventive apparatus incorporate devices using between fifty (50) and one thousand six hundred (1600) turns of insulated copper wire, because of the heat generated in the coil due to the inherent resistance of the wire to carry a current. The coils themselves may be a single coil or multiple individual coils in a stacked or adjacent relationship where the total number of coil windings is counted.

Within the coil assembly is/are an optional thermal sensor or array of thermal sensors of either the resistance or thermocouple type. The sensor(s) measure and allow quantification of the coil temperature at various points corresponding to their placement. The optional thermal sensor(s), therefore, enable the operator to monitor the amount of heat generated by the device during use.

The preferred power supply incorporates a variac type transformer capable of delivering up to the preferred amperage range of 0-15 amperes of current. The corresponding voltage to achieve the 0-15 ampere range depends upon the number of turns of wire used to form the coil, but typically includes a 110 or 220 volt (i.e., 110 V or 220 V) 60 cycle (hertz or Hz) supply voltage for studies done in the United States. Other supply voltages are contemplated depending upon the nature of the electrical distribution of the locality in which the apparatus is used. For example, a 60 hertz supply voltage is common in the United States while a 50 hertz supply voltage is common throughout Europe. The harmonic range for the 60 hertz supply and 50 hertz supply have common ranges and thus are believed to be equally useful in carrying out the discovered aspects of the present invention.

The AC input voltage applied to the coil is passed through a voltage regulating device for modulating (i.e., increasing or decreasing) the voltage as desired by the operator depending upon the application. In the alternative, where fixed voltages are used or desired, for example in the coil assembly embodiments having a large number of windings a transformer is used to provide a preselected steady state voltage (i.e., the working voltage from the variac type device) emerging therefrom. The working voltage is directed to a rectifier to convert the AC input to a DC output. The AC voltage is preferably rectified by a full-wave rectifier set.

The rectifier converts the applied AC current to a direct current (DC) with a resulting ripple frequency of either 60 cycles per second (i.e., half wave rectification) or 120 cycles per second (i.e., full wave rectification) depending upon the rectifier setup. The harmonics of 60 cycles or 120 cycles are also believed to be useful to achieve the desired result. Similarly, where fifty (50) cycle per second current is used as the AC supply voltage, the resulting ripple frequency is either 50 or 100 cycles per second depending upon the rectification. The nature of the wave form is best described as a DC one half sine wave configuration.

The invention may be summarized in a variety of ways, one of which is the following: an apparatus for inhibiting angiogenesis and retarding the growth of cancerous tumors present in mammalian subjects, comprising means for producing a magnetic field, wherein the means includes a coil assembly including at least one electrical conductor wrapped around a frame defining a coil assembly interior; and a source of rectified DC electrical energy for supplying a DC electrical current to the length of electrical conductor to create a magnetic field within the interior of the coil.

The at least one electrical conductor may further include a plurality of electrical conductors around the frame. The device also preferably includes an enclosure means for shielding the coil and allowing air flow as mentioned below. The enclosure means consists of a side plate and a cover. The cover may be removably attached to the frame to shield the coil, but it is preferably rigidly attached and difficult to remove. The frame is substantially elliptical in shape. In the preferred embodiment, at least one thermocouple sensor is positioned adjacent to at least one electrical conductor for measuring the temperature of the conductor.

The at least one electrical conductor is wrapped around the frame between 50 and 1600 times, and each of the plurality of electrical conductors may also be wrapped around the frame between 50 and 1600 times. The working current is preferably in the amperage range from approximately 5 amps and 10 amps, but other ranges such as between 2 and 20 amps are also believed to be useful and remain within the scope of the present invention.

A switch system capable of regulating the direction of the current flow through the coil is also provided. In the absence of natural magnets a switch means is not needed. A rectifier means for rectifying the incoming AC electrical energy is also provided. The rectifier means may provide either full wave or half wave DC rectification of a wave form associated with the DC electrical energy, and a plurality of DC bridge rectifiers may be used where the incoming AC working voltage and current is split from a single source to form a plurality of sources.

The present invention may also be summarized as a means for inhibiting angiogenesis and retarding the growth of cancerous tumors present in mammalian subjects, comprising a coil assembly including at least one electrical conductor wrapped around a frame defining a coil assembly interior; and a source of DC electrical energy for supplying a DC electrical current to the length of electrical conductor to create a magnetic field within the interior of the coil.

The present invention may also be summarized as an inventive apparatus capable of producing a magnetic field for retarding or inhibiting angiogenesis and the growth of cancerous tumors present in mammalian subjects, comprising a coil assembly including at least one length of electrically conducting wire wrapped about a frame which defines an interior of the coil assembly;



and DC voltage means for supplying a DC electrical current to the coil assembly to create a magnetic field within the interior of the coil assembly.

The method of the present invention may also be summarized as a method of inhibiting angiogenesis and/or retarding the growth rate of cancerous tumors present in a mammalian subject, the method comprising the steps of: providing a device for generating a magnetic field wherein the device has a frame and a coil of wire wrapped about the frame; producing a source of rectified DC current; connecting the source of DC current to the coil of wire; energizing the coil of wire with the DC current to create a magnetic field around the wire; and placing a biological subject having a cancerous tumor in the magnetic field to expose the biological subject to the field.

The present invention may also be summarized as follows: an apparatus for inhibiting angiogenesis and retarding the growth of cancerous tumors present in mammalian subjects, comprising means for producing a magnetic field, wherein the means includes a coil assembly including at least one electrical conductor wrapped around a frame defining a coil assembly interior; and a source of DC electrical energy for supplying a DC electrical current to the length of electrical conductor to create a magnetic field within the interior of the coil.

The at least one electrical conductor further includes a plurality of electrical conductors around the frame, and the preferred device further includes enclosure means for shielding the coil. The enclosure means comprises a side plate and a cover. A cover is removably attached to the frame to shield the coil; wherein the cover may be a cooperating cover and frame sized to establish a passage between the coil and the cover to form at least one duct to enable natural or forced gaseous (e.g., air) flow into and out of the passage from a location outside of the passage. In addition where multiple coils are used, the individual coils can be separated by a series of spacers and the like. The spacers enable air to flow in and around each individual coil winding for more efficient cooling.

The rectifier means is used to rectify the incoming AC electrical energy to DC. The rectifier means provides full or half wave DC rectification of a wave form associated with the DC electrical energy, and may include a plurality of DC bridge rectifiers. An optional thermocouple sensor is positioned adjacent to the at least one electrical conductor for measuring the temperature of the conductor. The coil is wrapped about the frame preferably between 50 and 1600 turns.

The preferred embodiment may also be summarized as follows: an inventive apparatus capable of producing a magnetic field for retarding angiogenesis and the growth of cancerous tumors present in mammalian subjects, comprising a coil assembly including at least one length of electrically conducting wire wrapped about a frame which defines an interior of the coil assembly; and DC voltage means for supplying a DC electrical current to the coil assembly to create a magnetic field

within the interior of the coil assembly.

The preferred embodiment may also be summarized as follows: a means for inhibiting angiogenesis and retarding the growth of cancerous tumors present in mammalian subjects, comprising a coil assembly including at least one electrical conductor wrapped around a frame defining a coil assembly interior; and a source of DC electrical energy for supplying a DC electrical current to the length of electrical conductor to create a magnetic field within the interior of the coil.

The preferred method may be summarized as follows: a method of inhibiting angiogenesis and retarding the growth rate of cancerous tumors present in a mammalian subject, the method comprising the steps of: providing a device for generating a magnetic field wherein the device has a frame and a coil of wire wrapped about the frame; producing a source of rectified DC current; connecting the source of DC current to the coil of wire; energizing the coil of wire with the DC current to create a magnetic field around the wire; and placing a biological subject having a cancerous tumor in the magnetic field to expose the biological subject to the field.

The device for generating a magnetic field is preceded by the step of configuring an inventive device capable of generating a magnetic field with a coil of wire having 50 and 1600 turns of wire wrapped around a frame.

The step of energizing the coil of wire further comprises the step of selecting an input current in the range of between 1 amp and 15 amps and exposing the biological subject to the magnetic field for a period of time greater than 5 minutes.

It is an object of the present invention to provide a device and method for inhibiting angiogenic activity and retarding the growth rate of cancerous tumors in biological subjects including mammals.

It is an object of the present invention to provide a device and associated method for inhibiting angiogenesis and retarding cancerous tumor growth in biological subjects including mammals.

It is an object of the present invention to provide a device and method capable of inhibiting angiogenic related conditions and retarding cancerous tumor growth in biological subjects including mammals.

It is an object of the present invention to provide a device and method for slowing or inhibiting the rate of angiogenesis and cancerous tumor growth in biological subjects including mammals.

It is an object of the present invention to provide an electrical device and method for inhibiting angiogenic activity and retarding cancerous tumor growth in biological subjects including

mammals.

It is an object of the present invention to provide an electrical device and associated method for inhibiting angiogenesis and retarding cancerous tumor growth in biological subjects including mammals.

5 It is an object of the present invention to provide an electrical device and method capable of inhibiting angiogenic related conditions and retarding cancerous tumor growth in biological subjects including mammals.

10 It is an object of the present invention to provide an electrical device and method for slowing or inhibiting the rate of angiogenesis and retarding cancerous tumor growth in biological subjects including mammals.

15 It is an object of the present invention to provide a method and/or apparatus for affecting the following as they relate to angiogenesis: Angiofibroma which is an abnormal formation of blood vessels which are prone to bleeding; Neovascular Glaucoma which is an abnormal growth of blood vessels in the eye; Arteriovenous malformations which is an abnormal communication between  
20 arteries and veins; Nonunion fractures which are fractures that will not heal; Lupus, and other Connective Tissue Disorders; Osler-Weber syndrome which is a genetic condition resulting in abnormal blood vessels which are prone to bleeding; Atherosclerotic plaques which is a hardening of the arteries; Psoriasis which is a common chronic skin condition; Corneal graft neovascularization which is a complication of corneal replacement surgery; Pyogenic granuloma which is a common skin  
25 lesion composed of blood vessels; Delayed wound healing; Diabetic retinopathy which is a leading cause of blindness in diabetics; Scleroderma which is a form of connective tissue disease; Granulations (burns); Neoplasm which is an abnormal cell growth forming solid tumors; Hemangioma which is a tumor composed of blood vessels; Trachoma which is a leading cause of blindness in some countries; Hypertrophic Scars which is abnormal scar formation; Retrolental fibroplasia which is abnormal growth of blood vessels in the retina; Hemophilic joints which is  
bleeding joints; Vascular adhesions which is excessive scarring; osteoarthritis and rheumatoid arthritis; macular degeneration; cancerous tumors generally; and pain.

30 These and other objects, features, and advantages of the present invention shall become apparent after consideration of the invention as defined above in conjunction with the disclosure provided herein, including the specification, drawings, and claims. All such objects, features and advantages are believed to be within the scope of the present invention even though not specifically set forth in this document.

**Brief Description of The Drawings**

Figure A is a schematic diagram of the cells of a blood carrying vessel;

Figure B is a schematic diagram similar to that of Figure A and including information relating to the initiation of angiogenesis;

5 Figure C is a schematic diagram similar to Figures A and B and including information relating to an advanced stage of angiogenesis sometime after the process was initiated;

Figures 1A and 1B are schematic block diagrams of the electrical components of the present invention;

10 Figure 2 is a side view of an embodiment of the present invention showing the relative orientation of the magnetic components and coil component and having a portion of the frame removed for clarity;

Figure 3 is a cross-sectional view taken along line A-A of Figure 2;

Figure 4 is side view of the preferred embodiment of the present invention showing the relative orientation of the coil component and having a portion of the frame removed for clarity;

15 Figure 5 is a cross-sectional view of the preferred embodiment taken along line A-A of Figure 4;

Figure 6 is an enlarged sectional view of the portion of the preferred embodiment bounded by the viewing circle of Figure 5 and further including a cover component;

Figures 7-9 are alternate embodiments of the present invention shown in Figure 6;

20 Figure 10 is a bar graph titled "Angiogenesis Assessment in 16/C [Mammary] Tumors" - Groups 1-8;

Figure 11 is a bar graph titled "Angiogenesis Assessment in 16/C [Mammary] Tumors - Groups 1-5";

25 Figure 12 is a bar graph titled "Angiogenesis Assessment in 16/C [Mammary] Tumors - Groups 1, 3, 6 and 7"; and

Figure 13 is a line graph titled "Response of SC 16/C Mammary Tumor to Exposure to Electromagnetic Fields"; and

Figure 14 is a graph illustrating the half rectified wave form produced by an embodiment of the present invention; and

30 Figure 15 is a graph illustrating the fully rectified wave form produced by an embodiment of the present invention; and

Figure 16 is a bar graph illustrating the harmonic range of the wave form illustrated in Figure 14; and

Figure 17 is a bar graph illustrating the harmonic range of the wave form illustrated in Figure 15.

### **Best Mode for Carrying Out the Invention**

5 With reference to the schematic diagrams designated as Figures 1A and 1B, a source of electrical energy, preferably 110 or 220 volts in the United States, is designated generally by the reference letter A. An AC transformer, designated generally by the reference letter B and labeled "VOLTAGE REGULATOR", is electrically connected to the source A by a conventional power cord preferably rated to handle the input voltage of the source.

10 The transformer varies the AC input voltage. The AC output is then passed through a single or series of bridge rectifiers C (i.e., labeled as "BRIDGE RECTIFIER"). The bridge rectifier(s) preferably provide either a full wave or half wave rectification of the wave form to a 60 or 120 cycles per second DC "positive" (i.e., above the reference line on a sinusoidal oscilloscope) wave form. The fully rectified wave form from the bridge rectifier(s) is then passed to the free ends of the coil designated generally by the reference letter D and labeled "DEVICE" for convenience.

15 Figure 14 and 15 are graphs illustrating the half rectified and fully rectified, respectively, wave form produced by an eight hundred (800) winding embodiment of the present invention. The sample graphs were taken when the field strength within the confines of the embodiment tested was set to produce 7.5 amps of current. Figures 16 and 17 illustrate the harmonics corresponding to the wave forms of Figures 14 and 15 respectively.

20 With reference to Figures 2 and 3, an embodiment of the device component of the present invention is designated generally by the reference number 600. A portion of the device frame 602 has been partially removed from Figure 2 in order to show the permanent magnets 604 and the interiorly wrapped coil 606 in their preferred orientation. The coil winding 606 overlies the belt or annular layer of permanent magnets 604. A cover 610 is provided as a means of protecting and shielding the coil 606 during operation.

25 Within the coil assembly are a plurality of optional thermal sensors (not shown in Figures 2 and 3), of either resistance or thermocouple type which measure and indicate the coil temperature at various points.

30 Cover 610 can be a section of raceway cover which includes a cooperating tongue and groove snap connection 612 so that the cover may be removed to service the interior magnetic and/or coil components of the device. As such, the existence of the cover attached to the device frame 602 and the disposition of the magnet and/or coil establish an air space 614 (Figure 3) between the frame

602, coil 606 and cover 610. The air space 614 provides a means of convective heat transfer such that if an air flow in the air space 614 were created, the flow of air would have a tendency to cool the coil 606 and magnets 604 when they become heated after the coil 606 is energized in the manner described below.

5           The orientation of the coil 606 and the magnets 604 is readily observed. Cross-section line A-A, which also serves as a vertical axis and horizontal line L, which serves as a horizontal axis, define the centroid of the interior channel 620 of the device. As shown in Figure 2, there are a pair of gaps 622 in the annular layer or belt of magnets 604. The gaps are provided so as to establish an open circuit condition in case the magnets themselves which are typically made of some metal do  
10           become conductors by virtue of their close proximity to the coil.

          With reference to Figures 4-5, the preferred embodiment of the coil assembly of the present invention is designated generally by the reference numeral 700. Embodiment 700 includes a frame component 702. The side plates 704 (see Figures 3-7) cover the coil 706 as it is wrapped around the frame 702. One of the side plates has been removed from Figure 2 for visual clarity of the coil  
15           706 but the side plates 704 are preferably rigidly attached to the frame 702 in a working embodiment of the invention.

          Within the coil assembly 704 are a plurality of optional thermal sensors 708, of either the resistance or thermocouple type. The sensors are provided as a way of measuring the coil temperature at various points but do not affect the operation of the invention and its useful effect  
20           (i.e., angiogenesis and growth retardation of cancerous tumors).

          A cover 710 is preferably rigidly secured to the frame. Attachment of the cover 710 to the frame 702 in the manner shown in the figures creates an air space 714 between the coil 706 and cover 710. The cover 710 may be snapped in place by a snap fit cooperation of the cover and the frame 712, or in the alternative the cover may be rigidly and securely attached by numerous other means  
25           of securement. The air space 714 allows for convective heat transfer from the coil 706 to the air within the air space 714. If an air flow is induced in the air space 714, the flow of air would have a tendency to cool the coil 706 if it heats up during use.

          With reference to Figures 5 and 6, the orientation of the frame 702, the side plates 704 and the coil 706, are readily observed. Cross-section line A-A of Figure 4, which also serves as a vertical  
30           axis V intersects the horizontal axis H to define an approximate interior centroid of the interior 716 of the device (Figure 4). When a current flow is induced into the coil 706, a magnetic field around the coil is established pursuant to the right hand rule. The magnetic lines of flux (not shown) are either to the left or to the right depending upon the frame of reference and the direction of current

flow in the coil 706.

Figures 6-9 illustrate a variety of device profiles in order to demonstrate the various configurations the coil 706 may have depending upon the width of the frame. As shown in Figures 6 and 9, the device may also multiple coils 706 in a stacked or adjacent relationship as denoted by the hypothetical dashed dividing line of those figures. An optimum coil thickness with respect to width is believed to help establish a more uniform minimum heat generation within the coil 706.

### **Industrial Applicability**

The use of the inventive apparatus for inhibiting angiogenesis can be best described in conjunction with a series of examples with supporting data that are set forth below.

Consideration of the known biological attributes of a healthy mammalian body were relied upon as known information for the experiments. All laboratory tests and experiments were performed on laboratory mice with active malignant cancer cells in an independent research laboratory facility and setting for affirmation. The intent of the experiments was to analyze the effectiveness of the inventive apparatus and method whose net intended result was proven to have a statistically significant affect to inhibit the normal expected rate of angiogenesis and retard cancerous tumor growth.

The following examples, therefore, set forth representative data obtained from some of the experiments and tests which were all conducted in a confidential, controlled setting. The procedure used for the mammalian animal tests can best be described as follows:

The device and a cooling fan to provide air flow in the air space were connected to a standard 110V or 220V electrical service. The device was allowed to warm up through one ten-minute cycle (either positive or negative direction on current flow through coil component). The input current level was adjusted to ten amps during warm up and adjusted periodically to maintain a steady state ten (10) amperes supply current. The net result, depending upon a positive direction or negative direction of current flow was a magnetic field generated from the coil combined with the background magnetic field associated with the magnets.

After warm up, the first animal subjects of this proof (i.e., laboratory mice of defined lineage) were placed onto a non-metallic shelf within the generated field. The operator selected a positive or negative direction of current flow through the coil component, as appropriate. The ten (10) amperes of supply current was verified and adjusted if necessary. Periodic checks were performed to maintain ten (10) amps.

A simple current timer as used at the outlet to cut power at the expiration of ten minutes

exposure of the subjects to the combined magnetic field. After ten minutes, the device was designed to automatically shut down. The first group of exposed subjects were then removed, placed back in their respective cages and the exposure was performed again and repeated with the next group until all of the subjects were exposed to either a positive or a negative combined field (depending upon the direction of current flow in the coil component), excepting the control animals which received no exposure to the combined field in any way. Measurements of tumor size and animal handling were conducted in accordance with the research facility protocol.

Twenty (20) control mice and ten (10) mice in each of the treatment groups (i.e., positive and negative direction of current flow through the coil component). All of the mice were selected from a single lineage as good laboratory and experimental practices dictate. Each mouse was implanted with "16/C mammary adenocarcinoma" which is known to be a fast growing "aggressive" tumor model. The treatment began when the median tumor weights reached 100 mg. The treatments were terminated when the tumors became too large to allow the study to continue due to humane considerations (approximately two weeks of treatment).

At the conclusion of the experiment, the mice were sacrificed and the tumors were analyzed by preparing cross-sectional tumor slides from 3 mice per cage Group (i.e., 3 control, 3 positive, and 3 negative). For each tumor, the independent researcher examined 5 sites on the slide to quantitate it for CD31 staining--a known standard of cellular staining. The data is reported in EXAMPLE ONE below.

#### STUDY 1 - EXAMPLE ONE:

Angiogenesis Assessed by CD31 Immunohistochemistry and Image Analysis in Murine 16/C Mammary Adenocarcinoma-Bearing C3H/HeJ Mice.

#### % CD31+ Comparison by Slides (sample of preliminary data)

Sample	Site 1	Site 2	Site 3	Site 4	Site 5	MEAN%	STD. DEV.
Cage Group 1-1	28.88	21.17	24.04	18.27	11.76	20.82	6.40
Cage Group 1-2	30.09	18.49	11.38	19.50	18.32	19.56	6.72
Cage Group 1-8	15.27	13.39	30.01	33.18	22.01	22.77	8.74
Cage Group 2-2	8.81	9.04	20.27	12.65	12.08	12.57	4.64
Cage Group 2-4	11.53	12.07	16.07	21.23	15.60	15.23	4.49
Cage Group 2-5	8.59	10.08	26.53	28.30	18.50	18.40	9.08
Cage Group 3-4	8.07	6.98	14.63	7.06	10.01	9.35	3.19



Cage Group 3-7	8.62	21.48	9.85	4.24	10.05	10.85	6.39
Cage Group 3-10	24.28	4.69	4.62	10.41	10.68	10.94	8.02

## Data Analysis:

5 By t-test,

Group 1 vs. Group 2,  $p = 0.0280$

Group 1 vs. Group 3,  $p < 0.0001$

Group 2 vs. Group 3,  $p = 0.0128$

## CD31+ Comparison by Cage Groups

10 Micro-vessel Density Assessed by CD31 Immunohistochemistry and Image Analysis

Sample	Treatment	MEAN%	STD. DEV.
Group 1	None	21.05	1.62
Group 2	Opposing	15.40	2.92
15 Group 3	Additive	10.38	0.89

“Additive” and “Opposing” refer to the orientation of the magnetic field line of flux associated with the permanent magnets and electromagnetic field lines from the coil by itself such that additive refers to an overlapping of the field lines while opposing refers to oppositely directed field lines.

20

## STUDY 2 - EXAMPLE TWO:

Angiogenesis Assessed by CD31 Immunohistochemistry and Image Analysis in Human A549 Lung Carcinoma-Bearing Athymic Mice.

25 Data Analysis:

By t-test,

Group 1 vs. Group 2,  $p < 0.0001$

Group 1 vs. Group 3,  $p < 0.0001$

Group 2 vs. Group 3,  $p < 0.0007$

30

## CD31+ Comparison by Cage Groups

Micro-vessel Density Assessed by CD31 Immunohistochemistry and Image Analysis

<u>Sample</u>	<u>Treatment</u>	<u>MEAN%</u>	<u>STD. DEV.</u>
5 Group 1	None	22.94	4.15

- 16 -

Group 2	Opposing	14.05	2.49
Group 3	Additive	10.23	2.18

“Additive” and “Opposing” refer to the orientation of the magnetic field line of flux associated with the permanent magnets and electromagnetic field lines from the coil by itself such that additive refers to an overlapping of the field lines while opposing refers to oppositely directed field lines.

#### STUDY 3 - EXAMPLE THREE:

##### Angiogenesis Assessed by CD31 Immunohistochemistry and Image Analysis in Murine 16/C Mammary Adenocarcinoma-Bearing C3H/HeJ Mice.

##### Micro-vessel Density Assessed by CD31 Immunohistochemistry and Image Analysis

<u>Sample</u>	<u>Treatment</u>	<u>MEAN%</u>	<u>STD. DEV.</u>
Group 1	None	18.67	2.28
Group 2	Natural Field	17.37	2.80
Group 3	electromagnetic field only	12.27	2.03
Group 4	natural and electromagnetic	15.81	1.21

Group 1 was the control group of tumor laden mice. They received no treatment but underwent the same standard care and handling as the other mice. Group 2 mice received exposure to fields generated by natural magnets only. Group 3 mice received exposure to electromagnetic fields only. Group 4 mice received exposure to a combined natural and magnetic field in an additive combination. “Additive” refers to the orientation of the magnetic field line of flux associated with the permanent magnets and electromagnetic field lines from the coil by itself such that corresponding fields overlapped.

#### STUDY 4 - EXAMPLE FOUR:

##### Angiogenesis Assessed by CD31 Immunohistochemistry and Image Analysis in Murine 16/C Mammary Adenocarcinoma-Bearing C3H/HeJ Mice.

The C3H mice in this example were implanted with murine 16/C mammary adenocarcinoma tumor cells. A control group (i.e., Group 1) of twenty mice was used. The mice in the control Group 1 were not treated with the inventive apparatus. Seven additional groups of ten mice each (Groups 2-8) were used for treatment.

Animals in Group 2 were placed within the interior of the device once daily for 3 minutes per day for 12 days beginning on day 8 following tumor implantation with the DC current at 5 amps.

Animals in Group 3 were placed within the interior of the device once daily for 10 minutes per day for 12 days beginning on day 8 following tumor implantation with the DC current at 5 amps.

Animals in Group 4 were placed within the interior of the device once daily for 40 minutes per day for 12 days beginning on day 8 following tumor implantation with the DC current at 5 amps.

5 Animals in Group 5 were placed within the interior of the device twice daily, at approximately 7 hour intervals) for 40 minutes for 12 days beginning on day 8 following tumor implantation with the DC current at 5 amps.

10 Animals in Group 6 were placed within the interior of the device once daily for 10 minutes per day for 12 days beginning on day 8 following tumor implantation with the DC current at 7.5 amps.

Animals in Group 7 were placed within the interior of the device once daily for 10 minutes per day for 12 days beginning on day 8 following tumor implantation with the DC current at 10 amps.

15 Animals in Group 8 were placed within the interior of the device twice daily, at approximately 7 hour intervals, for 10 minutes per day for 12 days beginning on day 8 following tumor implantation with the DC current at 10 amps.

20 During the study tumor weight was measured periodically and consistently to determine relative growth rates. Because of the sheer volume of raw data relating to %CD31+ angiogenesis assessment and tumor weight, graphical representation of the data will be used in this example instead of the tabular format used above. At the conclusion of the study the excised tumors were packed in the appropriate solution and frozen for further analysis.

25 With reference to Figures 10-13, it is clearly shown the tumors of the control group (i.e., Group 1) mice exhibited a more angiogenesis than any of the treated groups. It also appears that the Group 6 treated mice exhibited the least angiogenesis of any group and thus the preferred method of exposure for this invention, as it relates to duration, current level and time of exposure is that which is associated with the Group 6 treatment protocol. Figure 13 also shows the tumors of the mice of the treated groups grew more slowly and thus weighed less than the tumors of the control group (i.e., Group 1) mice.

What is claimed is:

1. An apparatus for retarding tumor angiogenesis related growth of cancerous tumors present in mammalian subjects, comprising:

means for producing a magnetic field, wherein the means includes:

a coil assembly including at least one electrical conductor wrapped around a frame defining a coil assembly interior; and

a source of DC electrical energy for supplying a DC electrical current to the length of electrical conductor to create a magnetic field within the interior of the coil.

2. The apparatus of Claim 1, wherein the at least one electrical conductor further includes: a plurality of electrical conductors around the frame.

3. The apparatus of Claim 1, further includes: enclosure means for shielding the coil.

4. The apparatus of Claim 3, wherein the enclosure means comprises: a side plate and a cover.

5. The apparatus of Claim 1 wherein: the frame is substantially elliptical in shape.

6. The apparatus of Claim 2, further including: enclosure means for shielding the plurality of electrical conductors.

7. The apparatus of Claim 1, further including: a cover removably attached to the frame to shield the coil.

8. The apparatus of Claim 1, further including: a switch system capable of regulating the direction of the current flow through the coil.

9. The apparatus of Claim 1, such that: rectifier means for rectifying the incoming AC electrical energy to DC.

10. The apparatus of Claim 9, such that:  
the rectifier means provides full wave DC rectification of a wave form associated with the DC electrical energy.

5 11. The apparatus of Claim 9, wherein the rectifier means further comprises:  
a plurality of DC bridge rectifiers.

12. The apparatus of Claim 11, wherein:  
the plurality of DC bridge rectifiers provide full wave DC rectification.

10 13. The apparatus of Claim 1, further including:  
at least one thermocouple sensor positioned adjacent to the at least one electrical conductor for measuring the temperature of the conductor.

15 14. The apparatus of Claim 1, wherein:  
the at least one electrical conductor is wrapped around the frame between 50 and 1600 times.

15 15. The apparatus of Claim 2, wherein:  
each of the plurality of electrical conductors is wrapped around the frame between 50 and  
20 1600 times.

16. An inventive apparatus capable of producing a magnetic field for retarding tumor angiogenesis related growth of cancerous tumors present in mammalian subjects, comprising:  
a coil assembly including at least one length of electrically conducting wire wrapped about  
25 a frame which defines an interior of the coil assembly; and  
DC voltage means for supplying a DC electrical current to the coil assembly to create a magnetic field within the interior of the coil assembly.

17. The apparatus of Claim 16, wherein the at least one length of electrically conducting wire  
30 further includes:  
a plurality of individual wires each of which are wrapped around the frame.

18. The apparatus of Claim 16, further includes:  
enclosure means for shielding the wire.
19. The apparatus of Claim 18, wherein the enclosure means comprises:  
5 a side plate and a cover.
20. The apparatus of Claim 16 wherein:  
the frame is substantially elliptical in shape.
- 10 21. The apparatus of Claim 17, further including:  
enclosure means for shielding the plurality of individual wires.
22. The apparatus of Claim 21, wherein the enclosure means further comprises:  
a cover removably attached to the frame to shield the coil.  
15
23. The apparatus of Claim 16, such that:  
a switch system capable of regulating the direction of the current flow through the wire.
24. The apparatus of Claim 16, such that:  
20 rectifier means for rectifying a wave form associated with the incoming DC electrical current.
25. The apparatus of Claim 24, such that:  
the rectifier means provides full wave DC rectification.
- 25 26. The apparatus of Claim 24, wherein the rectifier means further comprises:  
a plurality of DC bridge rectifiers.
27. The apparatus of Claim 26, wherein:  
the plurality of DC bridge rectifiers provide full wave DC rectification.  
30
28. The apparatus of Claim 16, wherein:  
the at least one electrically conducting wire is wrapped around the frame between 50 and  
1600 times.

29. The apparatus of Claim 17, wherein:  
each of the plurality of electrically conducting wires is wrapped around the frame between  
50 and 1600 times.

5 30. The apparatus of Claim 16, further including:  
at least one thermocouple sensor positioned adjacent to the at least one electrically  
conducting wire for measuring a temperature of the conductor.

10 31. A device for inhibiting angiogenesis and retarding the growth of cancerous tumors present  
in mammalian subjects, comprising:  
a coil assembly including at least one electrical conductor wrapped around a frame defining  
a coil assembly interior; and  
a source of DC electrical energy for supplying a DC electrical current to the length of  
electrical conductor to create a magnetic field within the interior of the coil.

15 32. The device of Claim 31, wherein the at least one electrical conductor further includes:  
a plurality of electrical conductors around the frame.

20 33. The device of Claim 31, further includes:  
enclosure means for shielding the coil.

34. The device of Claim 33, wherein the enclosure means comprises:  
a side plate and a cover.

25 35. The device of Claim 33 wherein:  
the frame is substantially elliptical in shape.

36. The device of Claim 32, further including:  
enclosure means for shielding the plurality of electrical conductors.

30 37. The device of Claim 31, further including:  
a cover removably attached to the frame to shield the coil.

38. The device of Claim 31, further including:  
a switch system capable of regulating the direction of the current flow through the coil.
39. The device of Claim 31, such that:  
5 rectifier means for rectifying the incoming DC electrical energy.
40. The device of Claim 39, such that:  
the rectifier means provides full wave DC rectification of a wave form associated with the  
DC electrical energy.
- 10 41. The device of Claim 39, wherein the rectifier means further comprises:  
a plurality of DC bridge rectifiers.
42. The device of Claim 41, wherein:  
15 the plurality of DC bridge rectifiers provide full wave DC rectification.
43. The device of Claim 31, wherein:  
the at least one electrical conductor is wrapped around the frame between 50 and 1600 times.
- 20 44. The device of Claim 32, wherein:  
each of the plurality of electrical conductors is wrapped around the frame between 50 and  
1600 times.
45. The device of Claim 31, further including:  
25 at least one thermocouple sensor positioned adjacent to the at least one electrical conductor  
for measuring a temperature of the conductor.
46. A method of inhibiting angiogenesis and retarding the growth rate of cancerous tumors  
present in a mammalian subject, the method comprising the steps of:  
30 providing a device for generating a magnetic field wherein the device has a frame and a coil  
of wire wrapped about the frame;  
producing a source of DC current;  
connecting the source of DC current to the coil of wire;



energizing the coil of wire with the DC current to create a magnetic field around the wire;  
and

placing a biological subject having a cancerous tumor in the magnetic field to expose the  
biological subject to the field.

5

47. The method of Claim 46, wherein the step of providing a device for generating a magnetic  
field is preceded by the step of:

configuring a device capable of generating a magnetic field with a coil of wire having 50 and  
1600 turns of wire wrapped around a frame.

10

48. The method of Claim 46, wherein the step of energizing the coil of wire further comprises  
the step of:

selecting an input current in the range of between 1 amp and 15 amps.

15

49. The method of Claim 46, further comprising the step of:

exposing the biological subject to the magnetic field for a period of time greater than 5  
minutes.

**AMENDED CLAIMS**

[received by the International Bureau on 25 October 1999 (25.10.99);  
original claims 1, 16, 31 and 46 amended;  
remaining claims unchanged (5 pages)]

1. An apparatus for retarding tumor angiogenesis related growth of cancerous tumors present in mammalian subjects, comprising:
  - 5 means for producing a magnetic field, wherein the means includes:
    - a coil assembly including at least one electrical conductor wrapped around a frame having a central passageway extending through the frame thereby defining a coil assembly interior for receiving a mammalian subject; and
    - a source of DC electrical energy for supplying a DC electrical current to the length
  - 10 of electrical conductor to create a magnetic field within the interior of the coil.
2. The apparatus of Claim 1, wherein the at least one electrical conductor further includes:
  - a plurality of electrical conductors around the frame.
- 15 3. The apparatus of Claim 1, further includes:
  - enclosure means for shielding the coil.
4. The apparatus of Claim 3, wherein the enclosure means comprises:
  - a side plate and a cover.
- 20 5. The apparatus of Claim 1 wherein:
  - the frame is substantially elliptical in shape.
6. The apparatus of Claim 2, further including:
  - 25 enclosure means for shielding the plurality of electrical conductors.
7. The apparatus of Claim 1, further including:
  - a cover removably attached to the frame to shield the coil.
- 30 8. The apparatus of Claim 1, further including:
  - a switch system capable of regulating the direction of the current flow through the coil.
9. The apparatus of Claim 1, such that:
  - rectifier means for rectifying the incoming AC electrical energy to DC.

10. The apparatus of Claim 9, such that:  
the rectifier means provides full wave DC rectification of a wave form associated with  
5 the DC electrical energy.
11. The apparatus of Claim 9, wherein the rectifier means further comprises:  
a plurality of DC bridge rectifiers.
- 10 12. The apparatus of Claim 11, wherein:  
the plurality of DC bridge rectifiers provide full wave DC rectification.
13. The apparatus of Claim 1, further including:  
at least one thermocouple sensor positioned adjacent to the at least one electrical  
15 conductor for measuring the temperature of the conductor.
14. The apparatus of Claim 1, wherein:  
the at least one electrical conductor is wrapped around the frame between 50 and 1600  
times.  
20
15. The apparatus of Claim 2, wherein:  
each of the plurality of electrical conductors is wrapped around the frame between 50  
and 1600 times.
- 25 16. An inventive apparatus capable of producing a magnetic field for retarding tumor  
angiogenesis related growth of cancerous tumors present in mammalian subjects, comprising:  
a coil assembly including at least one length of electrically conducting wire wrapped  
about a frame having a passageway extending through the frame which defines an interior of the  
coil assembly which is configured to receive a mammalian subject with cancerous tumors; and  
30 DC voltage means for supplying a DC electrical current to the coil assembly to create a  
magnetic field within the interior of the coil assembly.
17. The apparatus of Claim 16, wherein the at least one length of electrically conducting  
wire further includes:  
35 a plurality of individual wires each of which are wrapped around the frame.

29. The apparatus of Claim 17, wherein:  
each of the plurality of electrically conducting wires is wrapped around the frame  
5 between 50 and 1600 times.
30. The apparatus of Claim 16, further including:  
at least one thermocouple sensor positioned adjacent to the at least one electrically  
conducting wire for measuring a temperature of the conductor.
- 10 31. A device for inhibiting angiogenesis and retarding the growth of cancerous tumors  
present in mammalian subjects, comprising:  
a coil assembly including at least one electrical conductor wrapped around a frame which  
surrounds a central passageway thereby defining a coil assembly interior; and  
15 a source of DC electrical energy for supplying a DC electrical current to the length of  
electrical conductor to create a magnetic field within the interior of the coil.
32. The device of Claim 31, wherein the at least one electrical conductor further includes:  
a plurality of electrical conductors around the frame.
- 20 33. The device of Claim 31, further includes:  
enclosure means for shielding the coil.
34. The device of Claim 33, wherein the enclosure means comprises:  
25 a side plate and a cover.
35. The device of Claim 33 wherein:  
the frame is substantially elliptical in shape.
- 30 36. The device of Claim 32, further including:  
enclosure means for shielding the plurality of electrical conductors.
37. The device of Claim 31, further including:  
a cover removably attached to the frame to shield the coil.

35

38. The device of Claim 31, further including:  
a switch system capable of regulating the direction of the current flow through the coil.
- 5 39. The device of Claim 31, such that:  
rectifier means for rectifying the incoming DC electrical energy.
40. The device of Claim 39, such that:  
the rectifier means provides full wave DC rectification of a wave form associated with  
10 the DC electrical energy.
41. The device of Claim 39, wherein the rectifier means further comprises:  
a plurality of DC bridge rectifiers.
- 15 42. The device of Claim 41, wherein:  
the plurality of DC bridge rectifiers provide full wave DC rectification.
43. The device of Claim 31, wherein:  
the at least one electrical conductor is wrapped around the frame between 50 and 1600  
20 times.
44. The device of Claim 32, wherein:  
each of the plurality of electrical conductors is wrapped around the frame between 50  
and 1600 times.
- 25 45. The device of Claim 31, further including:  
at least one thermocouple sensor positioned adjacent to the at least one electrical  
conductor for measuring a temperature of the conductor.
- 30 46. A method of inhibiting angiogenesis and retarding the growth rate of cancerous tumors  
present in a mammalian subject, the method comprising the steps of:  
providing a device for generating a magnetic field wherein the device has a frame having  
a passageway and a coil of wire wrapped about the frame and surrounding the passageway;  
producing a source of DC current;  
35 connecting the source of DC current to the coil of wire;

energizing the coil of wire with the DC current to create a magnetic field around the wire; and

5 placing a biological subject having a cancerous tumor in the magnetic field established within the passageway and exposing the biological subject to the field therein.

47. The method of Claim 46, wherein the step of providing a device for generating a magnetic field is preceded by the step of:

10 configuring a device capable of generating a magnetic field with a coil of wire having 50 and 1600 turns of wire wrapped around a frame.

48. The method of Claim 46, wherein the step of energizing the coil of wire further comprises the step of:

15 selecting an input current in the range of between 1 amp and 15 amps.

49. The method of Claim 46, further comprising the step of:  
exposing the biological subject to the magnetic field for a period of time greater than 5  
minutes.

STATEMENT UNDER ARTICLE 19(1)

This paper is filed in conjunction with the claim amendments officially set forth on the attached application replacement pages provided pursuant to Rule 46.4. Claims 1 to 49 are pending in the application, and Claims 1, 16, 31, and 46 have been amended. The replacement pages are numbered to correspond exactly with the numbering of the originally filed pages being replaced.

Explanation of the Necessity for the Amendments

After consideration of the International Search Report, but more specifically the Category associated with each of the references, the Applicants have amended Claims 1, 16, 31 and 46 to incorporate the "passageway" of the frame as disclosed in the specification and drawings of the application. The addition of the "passageway" language is believed to more clearly distinguish the Applicants' invention from each and every reference, as well as any combination of references, cited in the International Search Report.

The originally filed specification and/or drawings are relied upon to provide the necessary support for the amendments to Claims 1, 16, 31 and 46. The specification and drawings disclose the claimed passageway as being associated with the interior of the coil assembly which is configured for receiving a mammalian subject when carrying out the method of the present invention.

1/14

BACKGROUND  
FIG. A

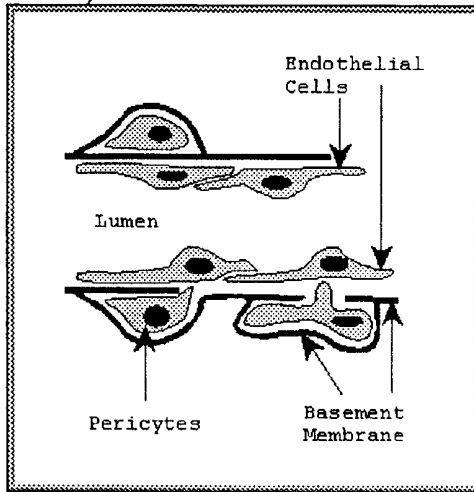

BACKGROUND  
FIG. B

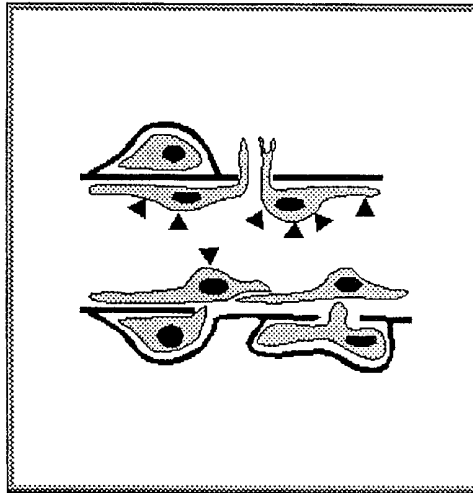

BACKGROUND  
FIG. C

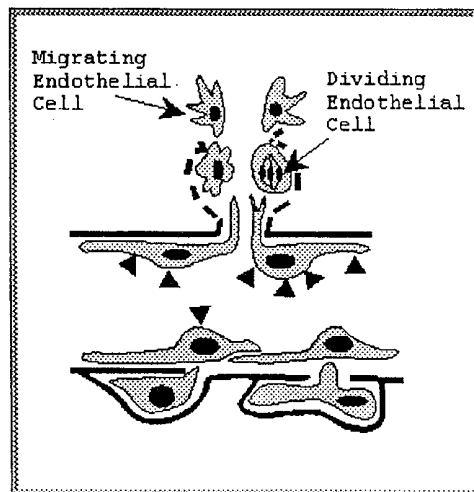



2/14

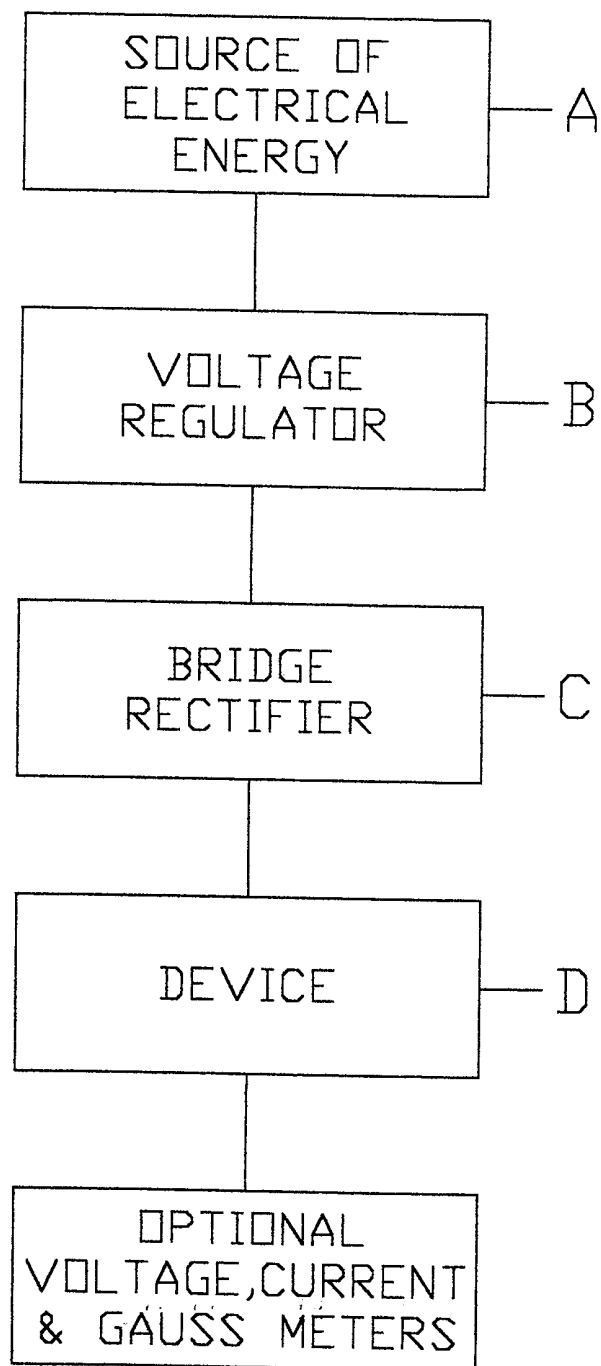

FIG. 1A

3/14

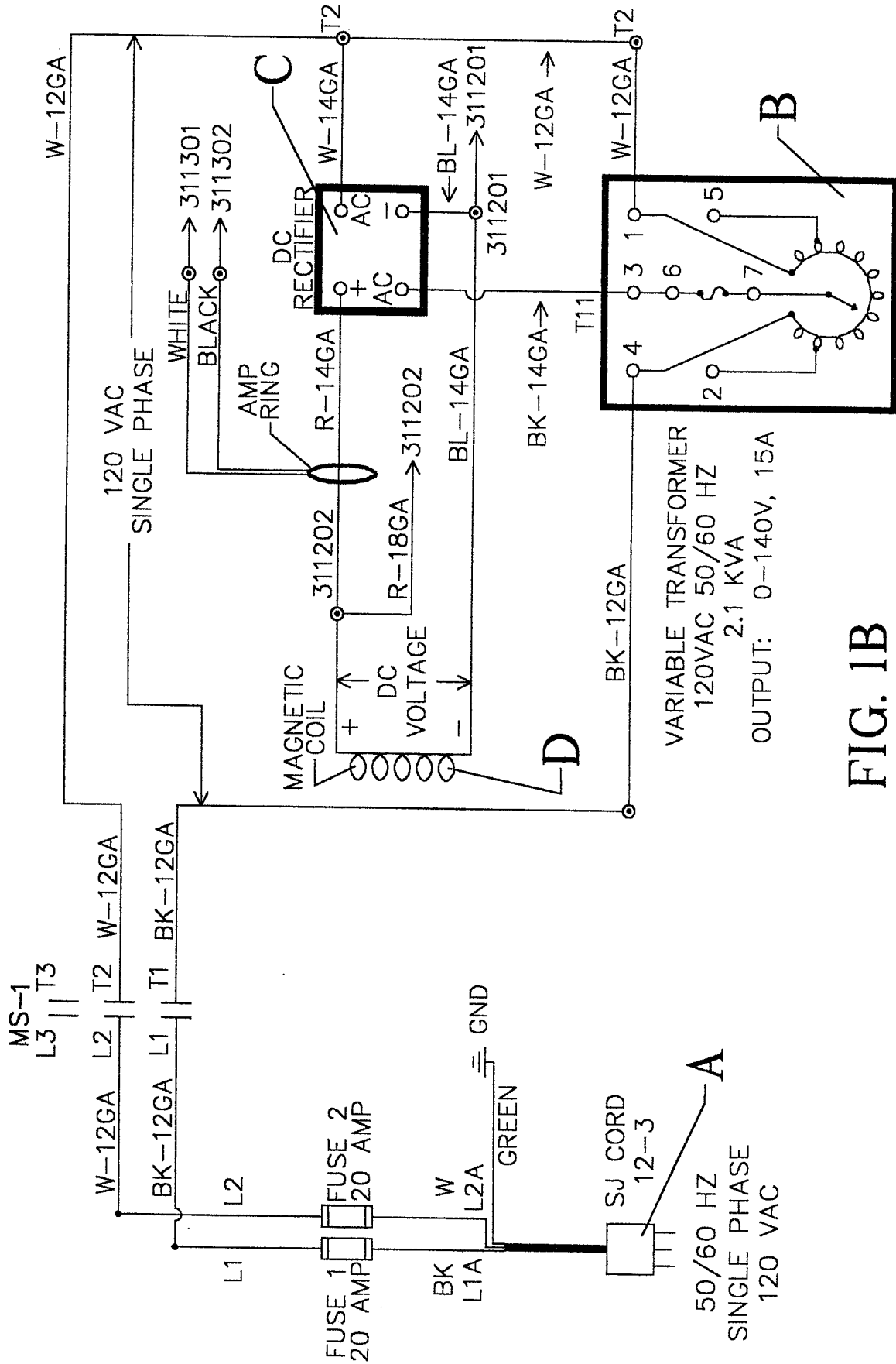

FIG. 1B

4/14

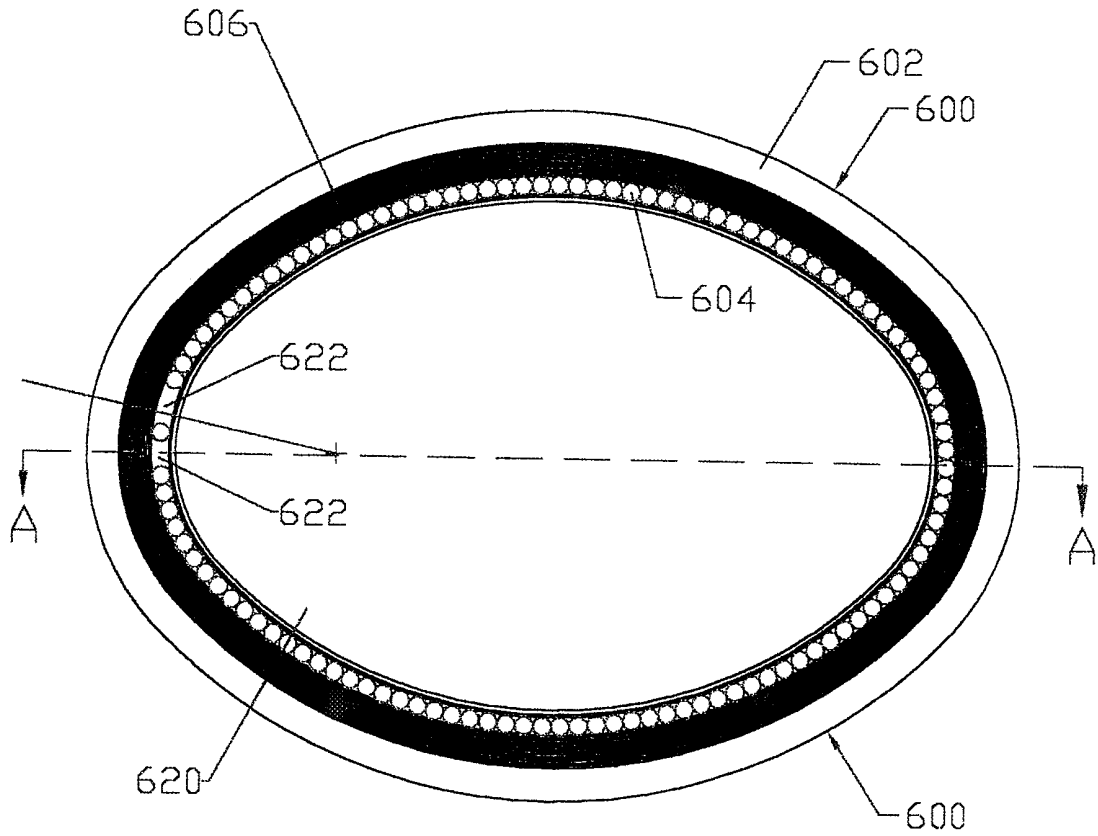

FIG. 2

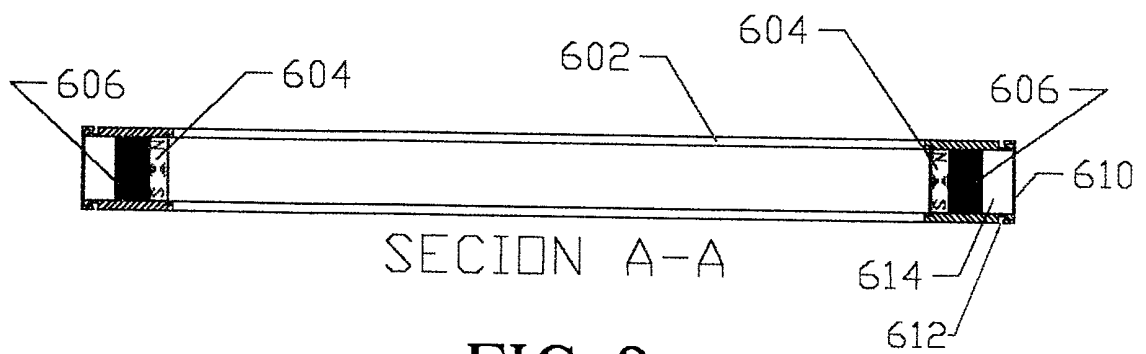

FIG. 3

5/14

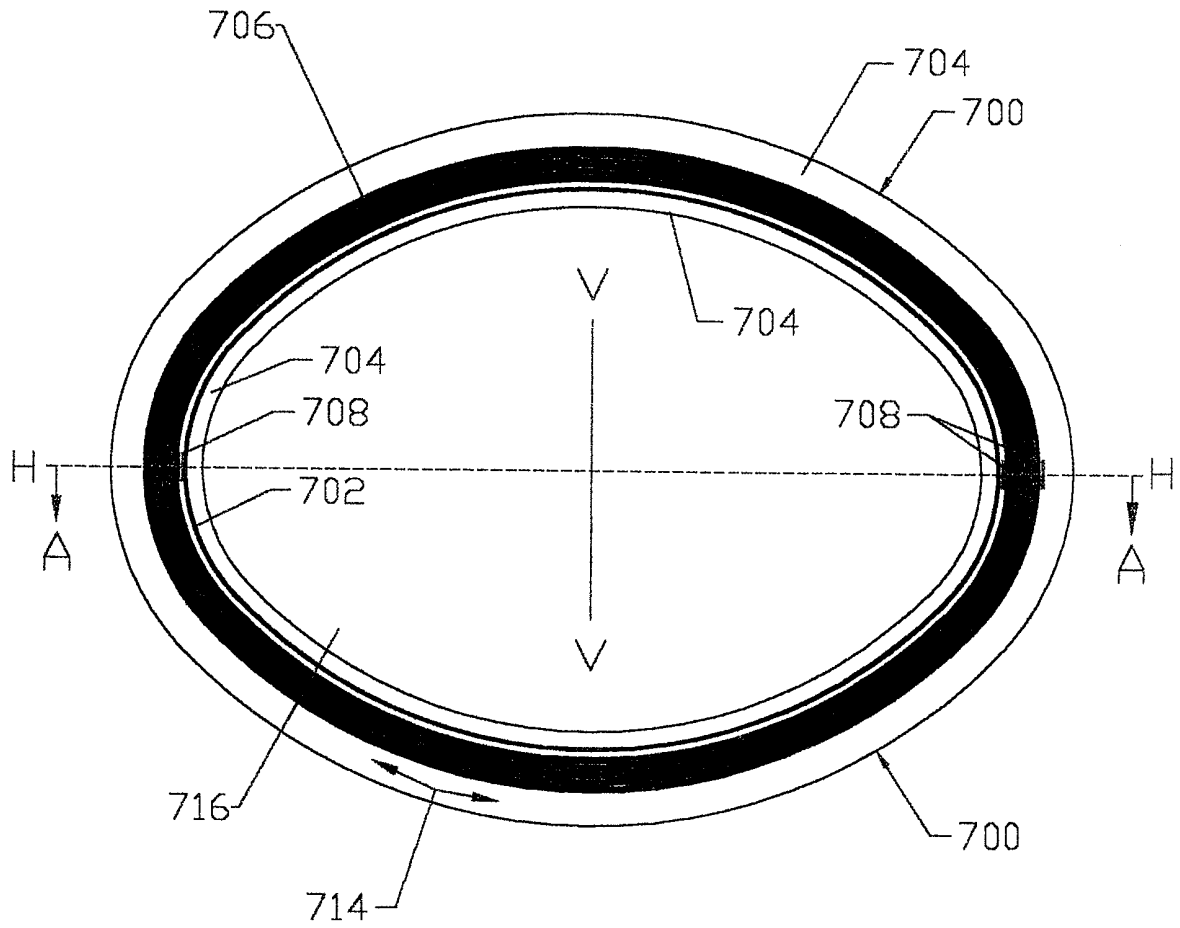

FIG. 4

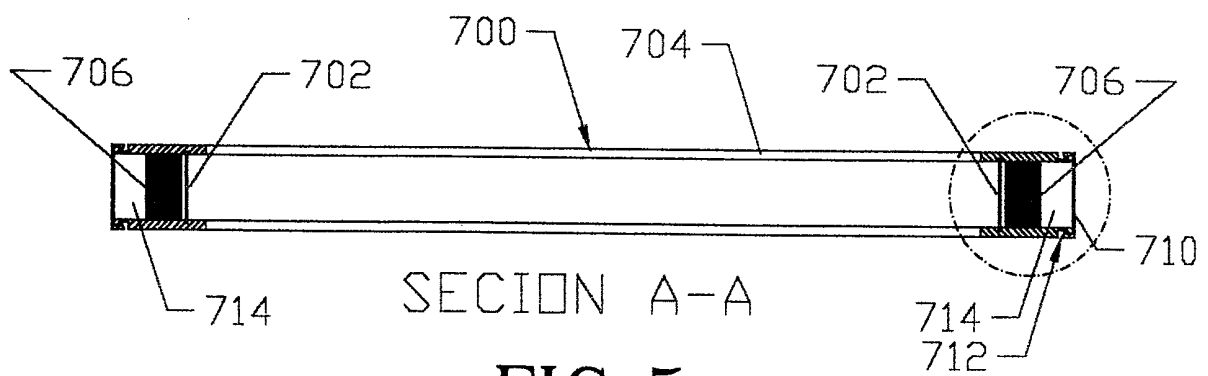

FIG. 5

6/14

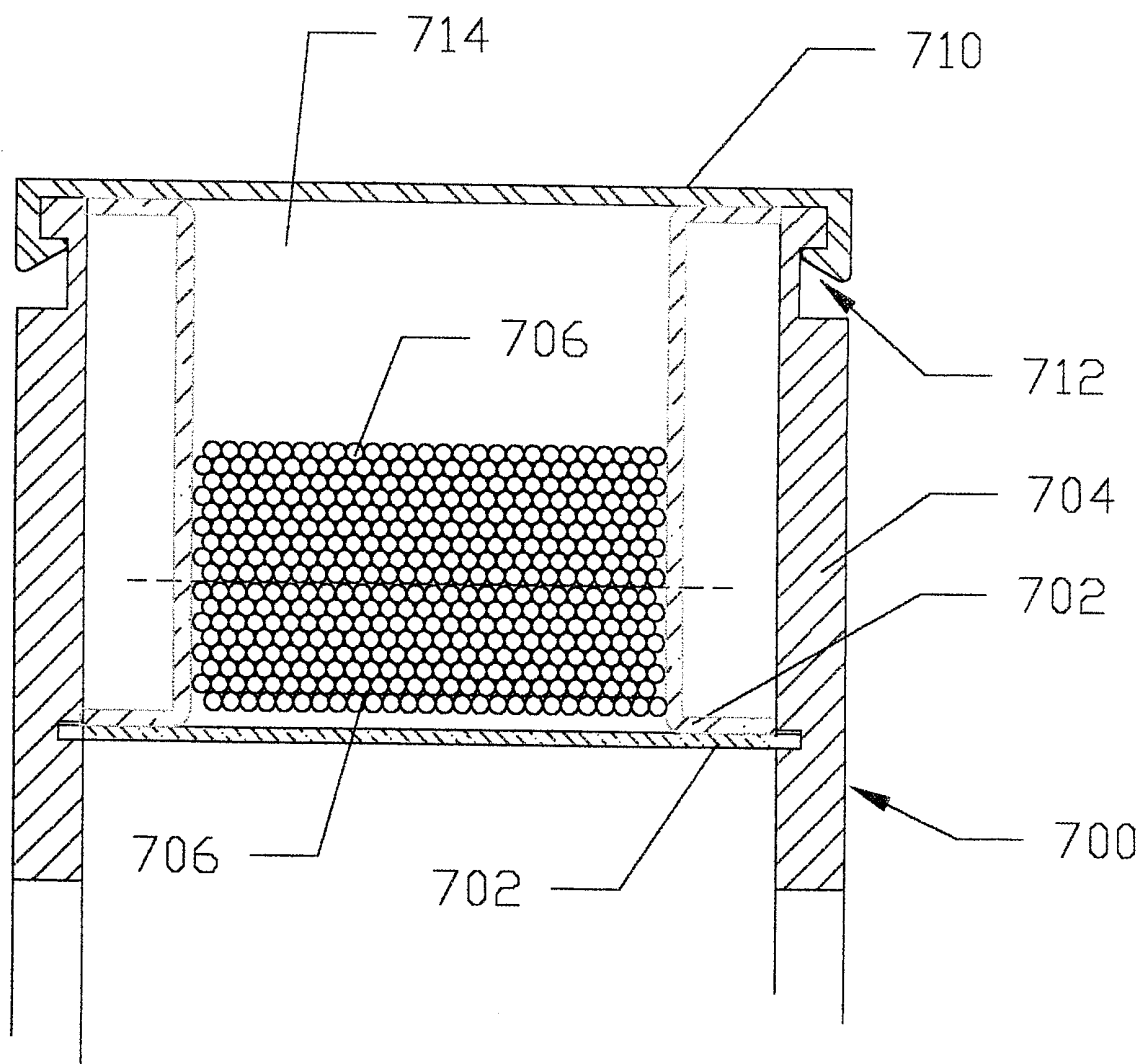

FIG. 6

7/14

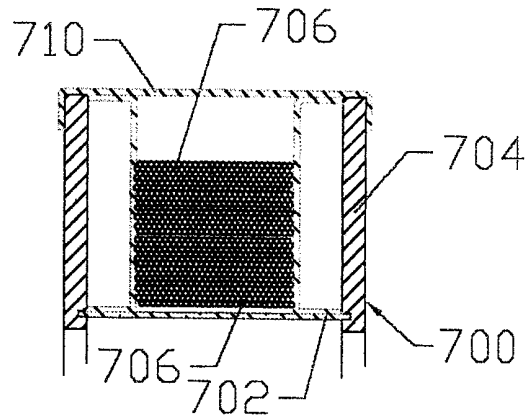

FIG. 7

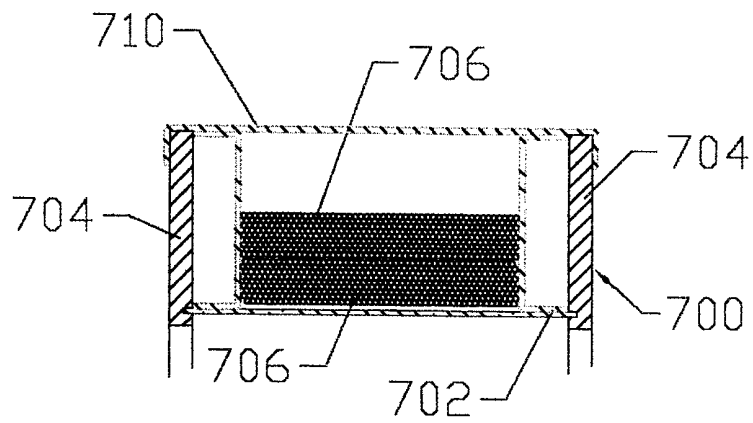

FIG. 8

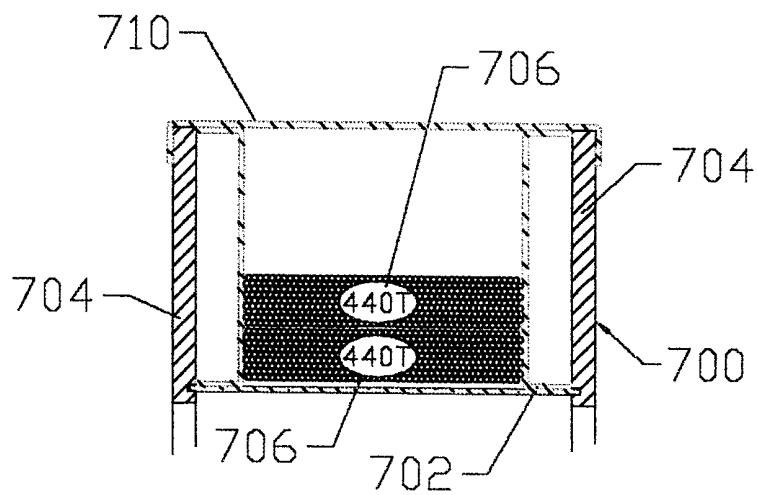

FIG. 9

8/14

Angiogenesis Assessment in 16/C Tumors  
Groups 1-8

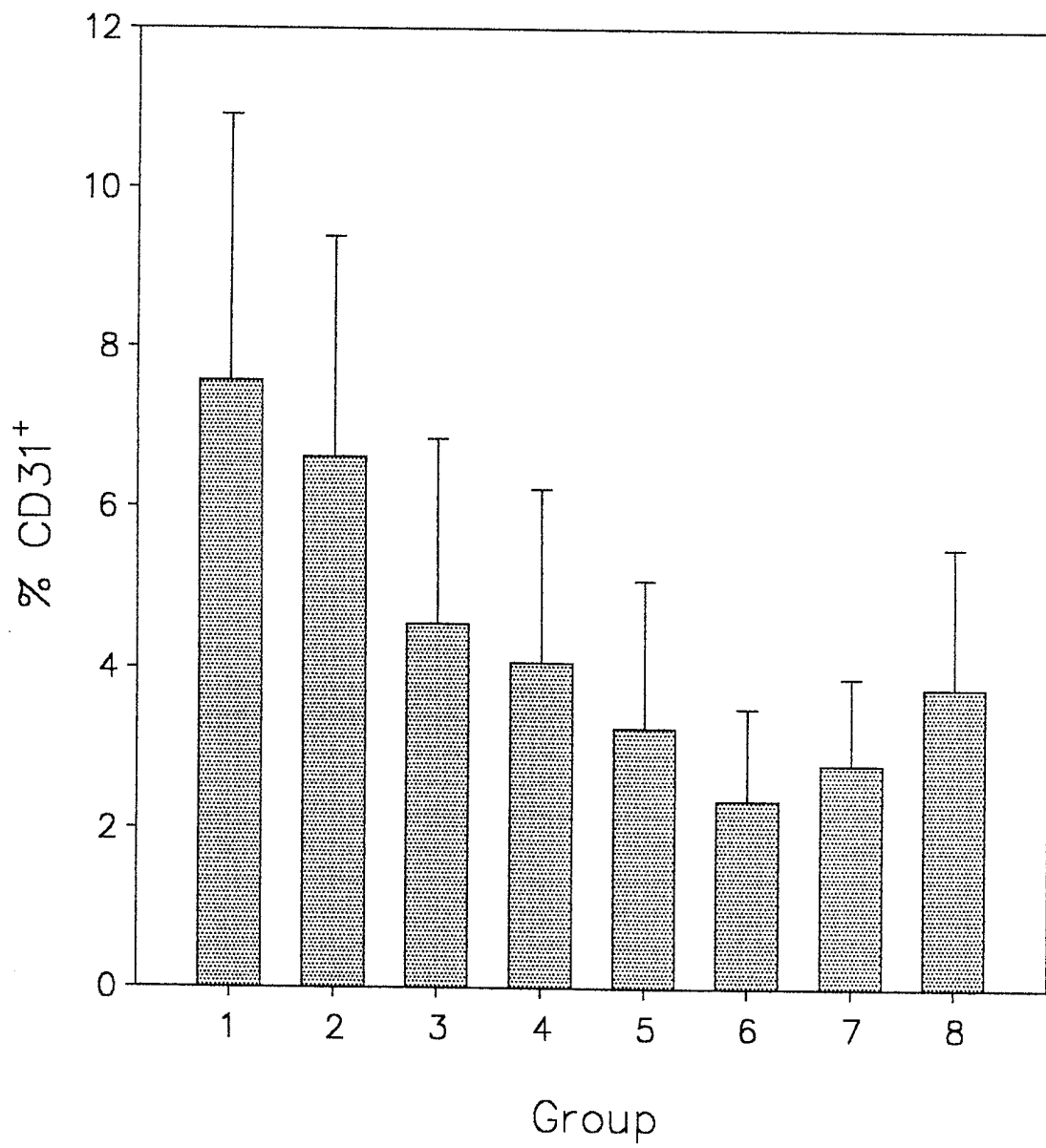

FIG. 10

9/14

Angiogenesis Assessment in 16/C Tumors  
Groups 1-5

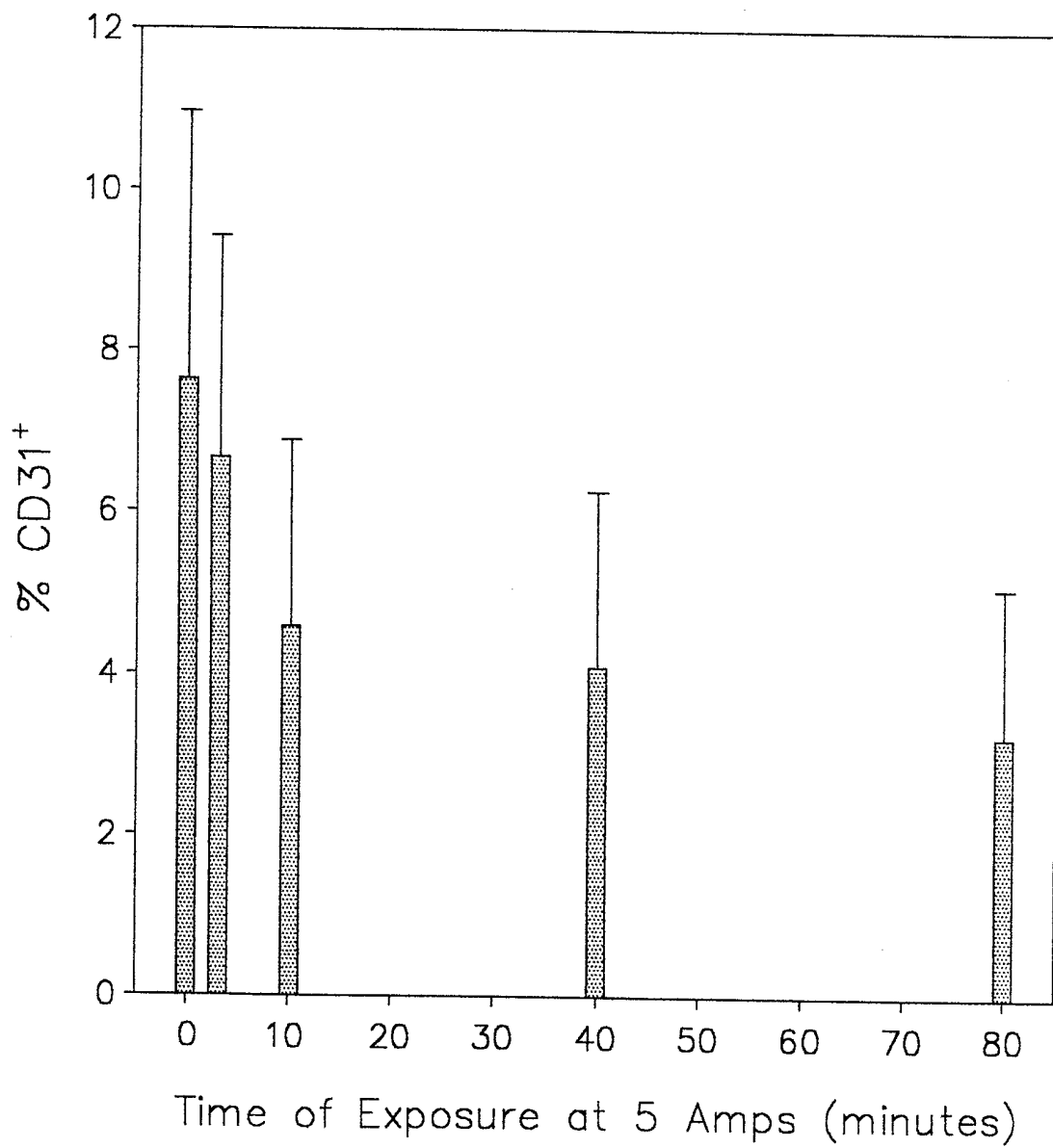

FIG. 11



10/14

Angiogenesis Assessment in 16/C Tumors  
Groups 1,3,6, and 7

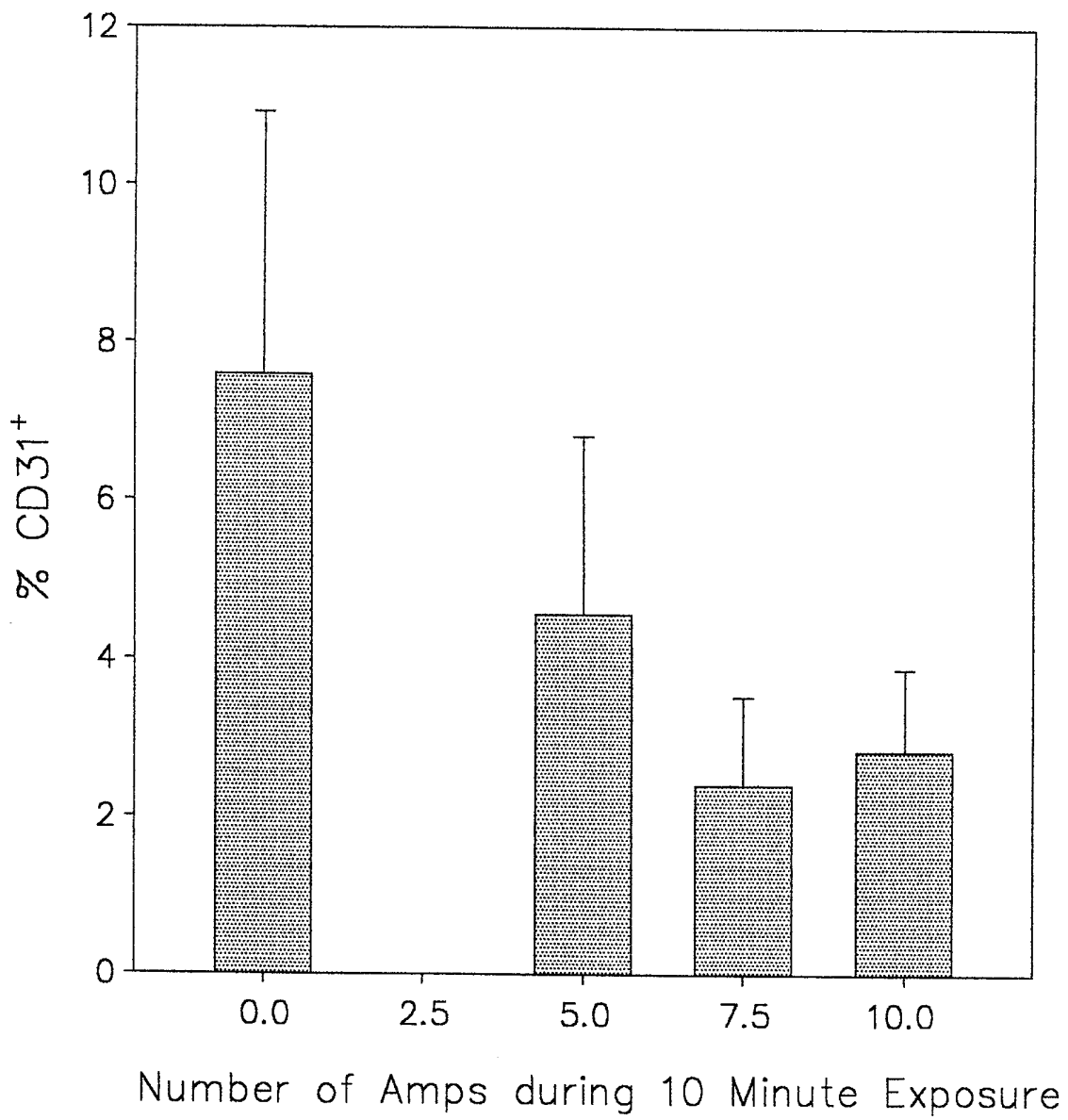

FIG. 12

11/14

Response of SC 16/C Mammary Tumor to Exposure to Electromagnetic Fields

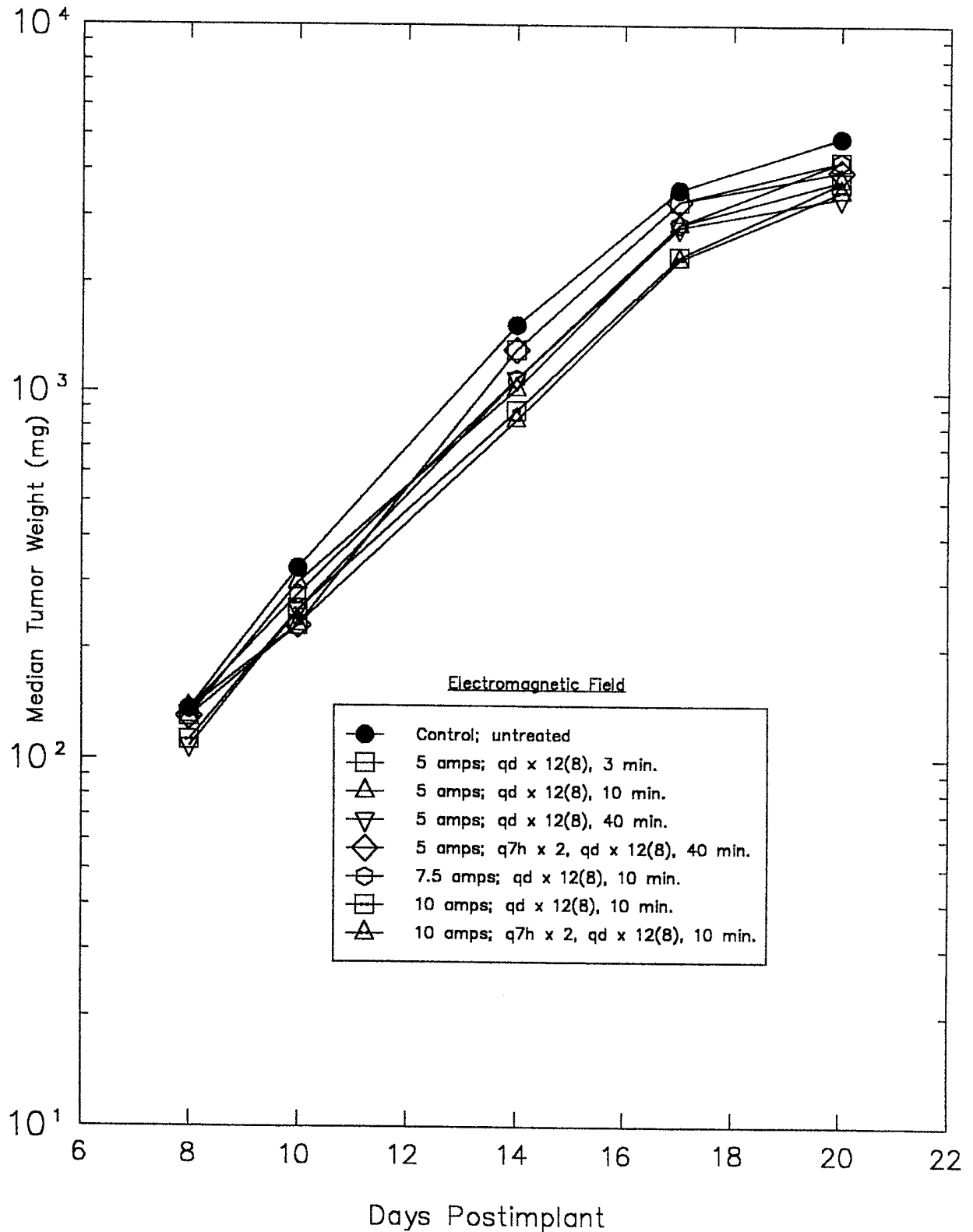

FIG. 13

12/14

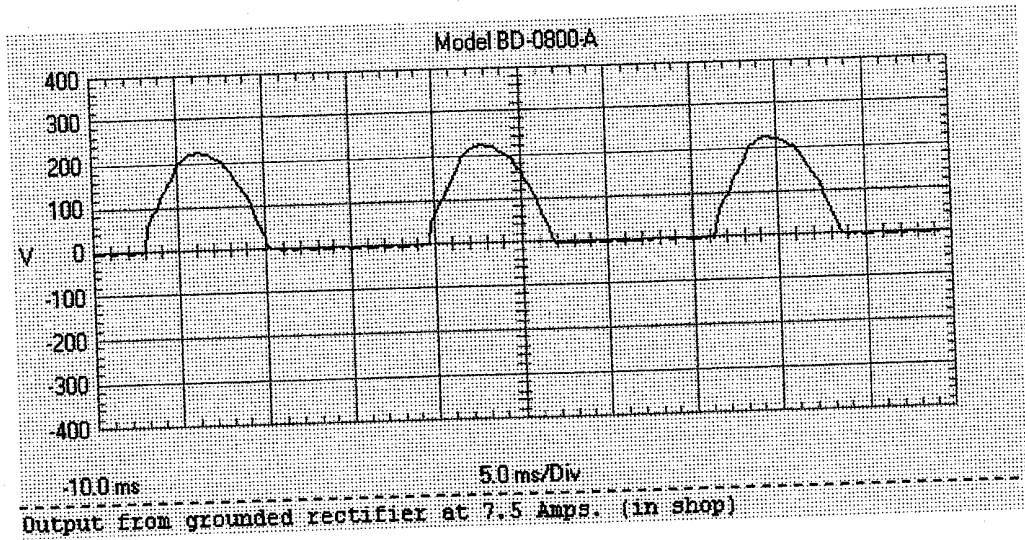

FIG. 14

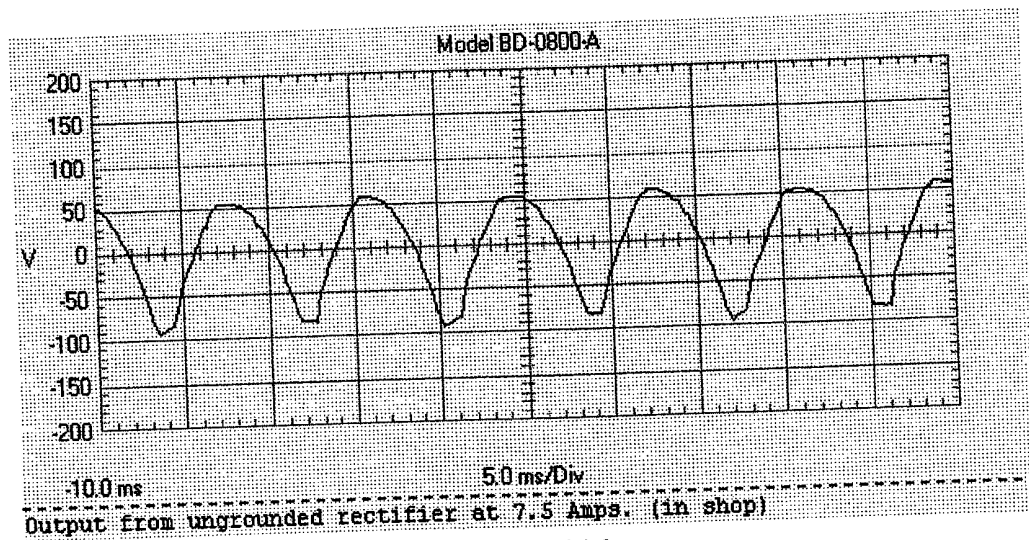

FIG. 15

13/14

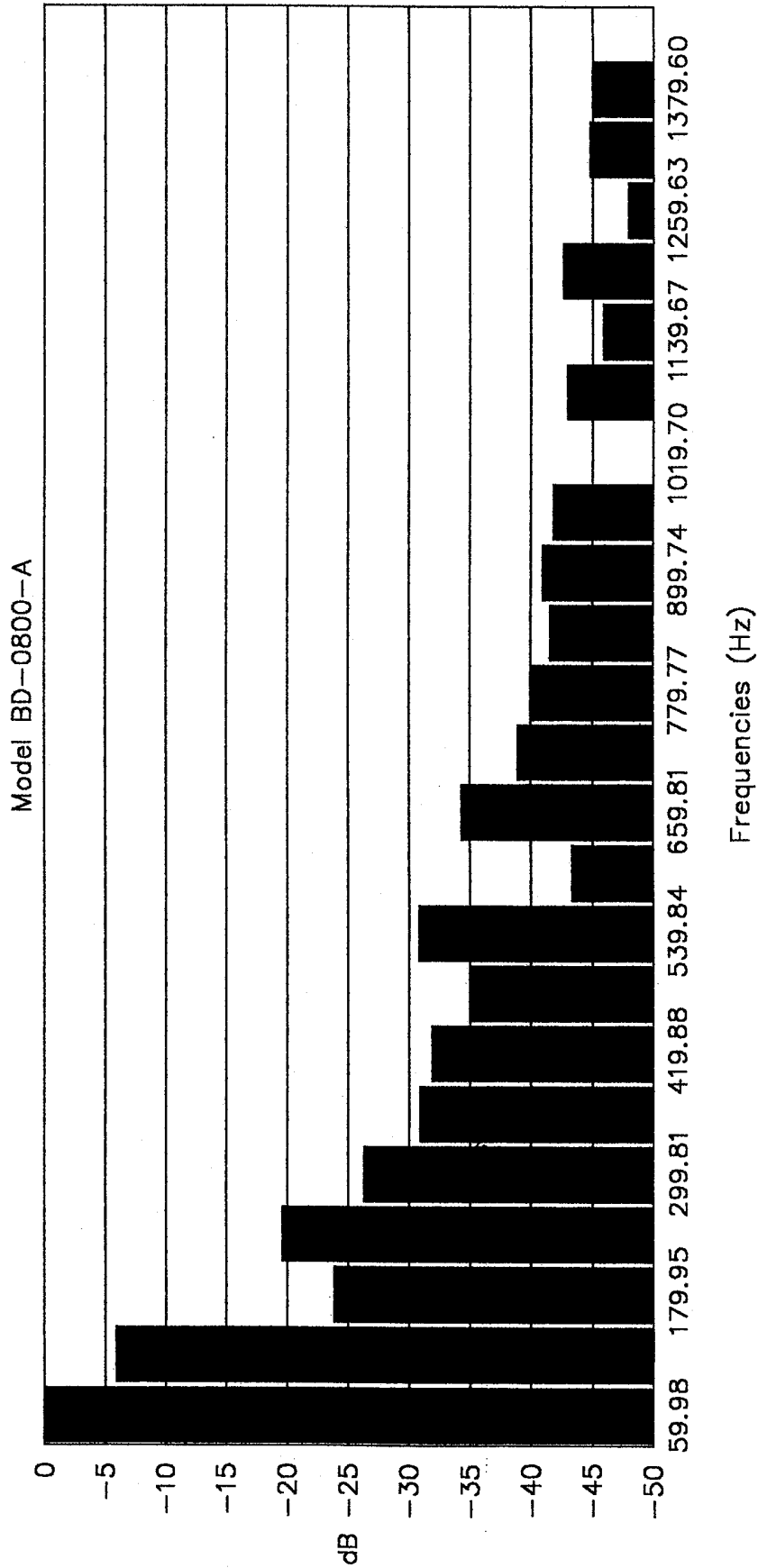

FIG. 16

14/14

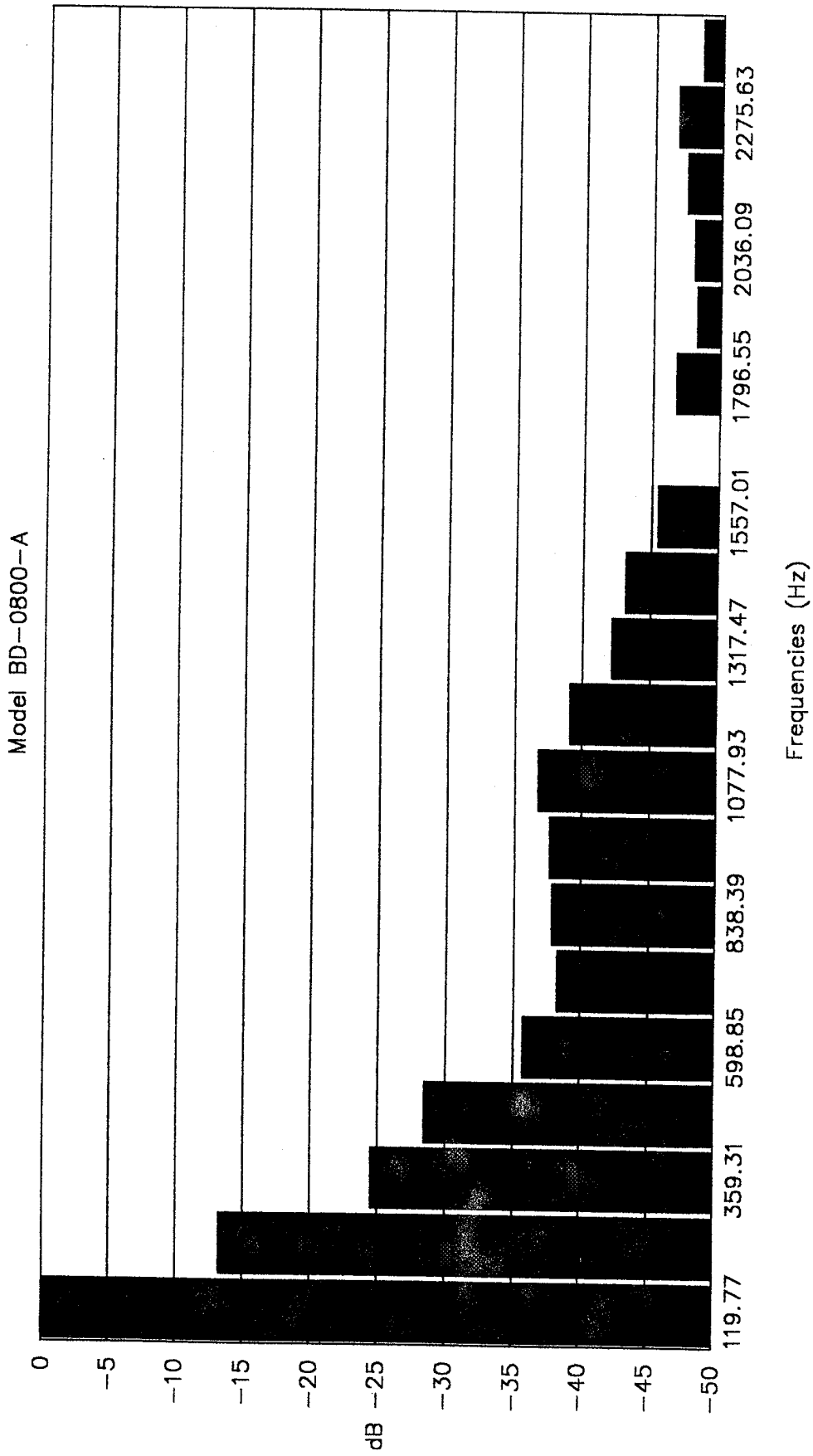

FIG. 17

# INTERNATIONAL SEARCH REPORT

International Application No

PCT/US 98/22135

**A. CLASSIFICATION OF SUBJECT MATTER**

IPC 6 A61K41/00 A61N2/02 A61N2/00

According to International Patent Classification (IPC) or to both national classification and IPC

**B. FIELDS SEARCHED**

Minimum documentation searched (classification system followed by classification symbols)

IPC 6 A61K A61N

Documentation searched other than minimum documentation to the extent that such documents are included in the fields searched

Electronic data base consulted during the international search (name of data base and, where practical, search terms used)

**C. DOCUMENTS CONSIDERED TO BE RELEVANT**

Category *	Citation of document, with indication, where appropriate, of the relevant passages	Relevant to claim No.
A	<p>CHEMICAL ABSTRACTS, vol. 128, no. 14, 6 April 1998 Columbus, Ohio, US; abstract no. 162643, IKEDA, SHIGEKI ET AL: "Enhancement of the effect of an angiogenesis inhibitor on murine tumors b hyperthermia" XP002101904 see abstract &amp; ONCOL. REP. (1998), 5(1), 181-184 CODEN: OCRPEW;ISSN: 1021-335X, ---</p> <p style="text-align: center;">-/--</p>	1-49

Further documents are listed in the continuation of box C.

Patent family members are listed in annex.

\* Special categories of cited documents :

- "A" document defining the general state of the art which is not considered to be of particular relevance
- "E" earlier document but published on or after the international filing date
- "L" document which may throw doubts on priority claim(s) or which is cited to establish the publication date of another citation or other special reason (as specified)
- "O" document referring to an oral disclosure, use, exhibition or other means
- "P" document published prior to the international filing date but later than the priority date claimed

- "T" later document published after the international filing date or priority date and not in conflict with the application but cited to understand the principle or theory underlying the invention
- "X" document of particular relevance; the claimed invention cannot be considered novel or cannot be considered to involve an inventive step when the document is taken alone
- "Y" document of particular relevance; the claimed invention cannot be considered to involve an inventive step when the document is combined with one or more other such documents, such combination being obvious to a person skilled in the art.
- "&" document member of the same patent family

Date of the actual completion of the international search

4 May 1999

Date of mailing of the international search report

18/05/1999

Name and mailing address of the ISA

European Patent Office, P.B. 5818 Patentlaan 2  
NL - 2280 HV Rijswijk  
Tel. (+31-70) 340-2040, Tx. 31 651 epo nl,  
Fax: (+31-70) 340-3016

Authorized officer

Berte, M

# INTERNATIONAL SEARCH REPORT

Interr. Application No

PCT/US 98/22135

C.(Continuation) DOCUMENTS CONSIDERED TO BE RELEVANT		
Category °	Citation of document, with indication, where appropriate, of the relevant passages	Relevant to claim No.
Y	CHEMICAL ABSTRACTS, vol. 124, no. 3, 15 January 1996 Columbus, Ohio, US; abstract no. 27689, ROBINS, H. IAN ET AL: "Cytokine induction by 41.8.degree.C whole body hyperthermia" XP002101905 see abstract & CANCER LETT. (SHANNON, IREL.) (1995), 97(2), 195-201 CODEN: CALEDQ;ISSN: 0304-3835,	1-49
A	DE 196 00 744 A (KAISER WERNER ALOIS PROF DIPL) 17 July 1997 see claims; figure 1	1-49
X	US 5 195 940 A (BAYLINK DAVID J) 23 March 1993 see claims	1-49
Y	see claims	1-49
A	EP 0 371 504 A (JACOBSON JERRY I) 6 June 1990 see claims	

# INTERNATIONAL SEARCH REPORT

International application No.

PCT/US 98/ 22135

## Box I Observations where certain claims were found unsearchable (Continuation of item 1 of first sheet)

This International Search Report has not been established in respect of certain claims under Article 17(2)(a) for the following reasons:

1.  Claims Nos.: 46-49  
because they relate to subject matter not required to be searched by this Authority, namely:  
Remark: Although claims 46-49  
are directed to a method of treatment of the human/animal  
body, the search has been carried out and based on the alleged  
effects of the compound/composition.
2.  Claims Nos.:  
because they relate to parts of the International Application that do not comply with the prescribed requirements to such  
an extent that no meaningful International Search can be carried out, specifically:
3.  Claims Nos.:  
because they are dependent claims and are not drafted in accordance with the second and third sentences of Rule 6.4(a).

## Box II Observations where unity of invention is lacking (Continuation of item 2 of first sheet)

This International Searching Authority found multiple inventions in this international application, as follows:

1.  As all required additional search fees were timely paid by the applicant, this International Search Report covers all  
searchable claims.
2.  As all searchable claims could be searched without effort justifying an additional fee, this Authority did not invite payment  
of any additional fee.
3.  As only some of the required additional search fees were timely paid by the applicant, this International Search Report  
covers only those claims for which fees were paid, specifically claims Nos.:
4.  No required additional search fees were timely paid by the applicant. Consequently, this International Search Report is  
restricted to the invention first mentioned in the claims; it is covered by claims Nos.:

Remark on Protest

- The additional search fees were accompanied by the applicant's protest.
- No protest accompanied the payment of additional search fees.



# INTERNATIONAL SEARCH REPORT

information on patent family members

Interr. Application No
PCT/US 98/22135

Patent document cited in search report	A	Publication date	Patent family member(s)	Publication date
DE 19600744	A	17-07-1997	AU 1310697 A WO 9725062 A	01-08-1997 17-07-1997
US 5195940	A	23-03-1993	US 5330410 A WO 9300131 A	19-07-1994 07-01-1993
EP 0371504	A	06-06-1990	AT 147646 T AU 641370 B AU 4568089 A CA 2004192 A DE 68927667 D DE 68927667 T JP 2195969 A US 5269746 A	15-02-1997 23-09-1993 07-06-1990 31-05-1990 27-02-1997 21-08-1997 02-08-1990 14-12-1993