

March 7, 1967

G. ALFIERI ET AL

3,307,580

DEVICE FOR COMMUTATIVELY CREATING SHUT-OFF MEMBERS FOR FLUIDS
IN GENERAL PARTICULARLY FOR RECIPROCATING MOTORS
Filed Sept. 18, 1964

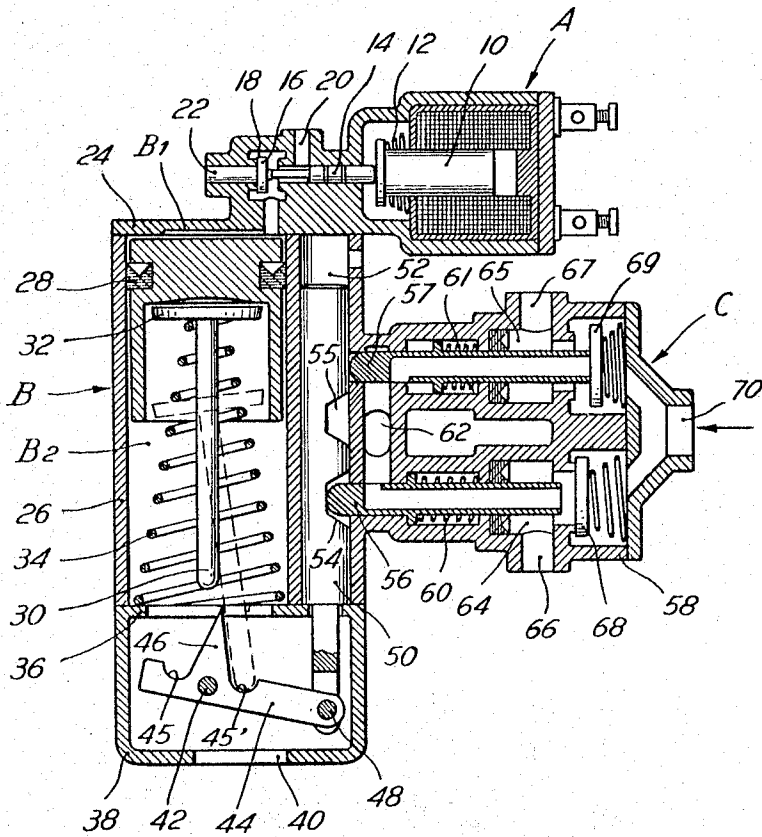

3,307,580

DEVICE FOR COMMUTATIVELY CREATING SHUT-OFF MEMBERS FOR FLUIDS IN GENERAL PARTICULARLY FOR RECIPROCATING MOTORS

Giuseppe Alfieri and Roberto Moriondo, Milan, Italy, assignors to Fabbrica Italiana Magneti Marelli S.p.A., Milan, Italy, a corporation of Italy

Filed Sept. 18, 1964, Ser. No. 397,409

Claims priority, application Italy, Sept. 16, 1963, 18,921/63

4 Claims. (Cl. 137—624.18)

This invention relates to a device for commutatively operating fluid shut-off members which finds an application in all of such apparatus utilizing a compressed fluid, such as for example, reciprocating motors in which two chambers of the considered fluid-operated apparatus are alternatively put into communication either with a source of pressure fluid or with the discharge.

Usually, in order to operate these types of pressure fluid apparatus, distributors are used, the operation of which requires particular constructional provisions; moreover, it is required that said control be made in a simple and quick manner, such as, for example, the one which may be obtained by pressing a pushing member acting on a push-button.

The device in question allows that the object be reached so that the supply, to a part or section of the fluid-operated apparatus, of the fluid under pressure, also establishes the connection with the discharge of the remaining portion of said fluid-operated apparatus.

The device according to this invention is characterized in that it comprises a pushing member provided with a fulcrumed spring-biased rod which is adapted to act on a rocker carrying a deflecting member adapted to alternatively bring in engagement said connecting rod with either one or the other of the ends of the rocker and means connected with said rocker to act on at least one commutable shut-off member, adapted to connect the fluid-operated apparatus with either the discharge or the source of fluid under pressure.

According to the invention, the pushing member is biased by spring means which maintain it in a predetermined rest position and said spring means also act on the connecting rod which is engageable commutatively with one or the other of the two arms of the rocker, the latter having, at its pivot pin, a deflecting tile with which the end of the connecting rod is alternatively engaged in order that it be deflected toward the end of the rocker to be actuated.

The above-stated principle can bring about different embodiments of the device and this depending on the characteristics of the use and the purposes to be reached. Thus, for example, the pushing means can be actuated by manual direct control or by mechanical, electronic, or pneumatic remote control. The rocker can directly or indirectly actuate, through slides, cams and the like, one or more commutable shut-off members; for example, in the case of reciprocating motors, the device can comprise two commutable shut-off members which may be alternatively actuated so that, when one of the chambers of said motor is supplied with the fluid under pressure, the other is connected with the discharge, and vice-versa.

The invention will now be disclosed in the following description by reference to the accompanying drawing in which the sole figure is a diagrammatic axial cross-section of a preferred embodiment of the device operated, through electromagnetic controls, by a fluid under pressure which commutatively acts on two shut-off members which are in turn commutable.

In said figure, A designates an electromagnet which

controls the actuation of the device B, which, in turn, actuates the shut-off members C which are connected with the fluid-operated apparatus, not shown.

The armature 10 of the electromagnet A is biased by a spring 12 and is connected by means of a rod 14 with a shut-off valve 16 of a changing-over or commutable type which is adapted to control the communication between a chamber 18 and either a discharge opening 20 or a passage 22 connected with a source of fluid under pressure.

Said armature 10 of the electromagnet A, biased by spring 12, maintains securely the shut-off valve 16 seated in its seat to intercept the communication between chamber 18 and passage 22.

Electromagnet A and the parts just considered are carried by a cover 24 which closes a cylinder 26 in which a piston 28 of the device B previously considered tightly slides, and chamber B1 defined in said cylinder by piston 28 is connected with chamber 18 as will be hereinafter explained.

The connecting rod 30 of piston 28 co-operates with said piston through a hinge comprising a cup 32 enabling said connecting rod to suitably oscillate, and a spring 34, which is held at the lower end by a flange 36 in a casing 38 which closes said cylinder 26, acts on said cup pressing piston 28 against cover 24.

Chamber B2 of this cylinder is connected with atmosphere through a port 40 in the bottom of casing 38.

Arranged normally to the axis of piston 28, there is a pivot pin 42 which is carried by the walls of casing 38, said pivot pin 42 mounting a rocker 44 having in its intermediate section (that is at pivot pin 42) a triangular lug 46 whereby the free end of connecting rod 30 may alternatively co-operate with the two inclined faces of said lug.

One of the ends of rocker 44 is connected, by means of a pivot pin 48, with a rod or slide 50 which is slidably guided in a chamber 52 which is arranged laterally of cylinder 26. Said slide has, in suitable positions, one or more notches (two, in the case illustrated) 54 and 55 in each of which the shaped end of bored pushrods 56 and 57 respectively may alternatively be engaged, said pushrods being guided in the body of shut-off members C and laterally placed with respect to cylinder 26.

Springs 60 and 61, the action of which causes the engagement of pushrods 56 and 57 within the respective notches in slide 50, act on said pushrods. Pushrods 56 and 57 have axial bases therein and both of said bores are connectable with a chamber which, by means of an opening 62, is connected with the discharge or vent.

The opposite ends of the bores of said pushrods lead to respective chambers 64 and 65 which are connected through connections or passages 66 and 67, with the fluid operated member, such as for example the two chambers of a piston-cylinder type reciprocating motor or a rotary blade type motor.

Chambers 64 and 65 are connected, through valves 68 and 69, with a connection 70 leading to the source of fluid under pressure.

Valves 68 and 69 are conventionally pressed against the respective seats to shut-off the communication between either connections 66-70 or 67-70, and said valves are moved away from the respective seats by the hollow ends of pushrods 56 and 57.

Owing to the arrangement of notches 54 and 55 in slide 50, either of said pushrods 56 and 57 raises the respective valve 68 and 69 to establish the communication between connection 70 and either connections 66 or 67, whereas the other pushrod connects the other connection 67, or 66, with discharge 62.

The operation of the device is clear; upon the energiza-

3

tion of A, the armature 10 of the latter is attracted and it displaces valve 16 which, on one hand, establishes communication between chamber 18 and connection 22 and, on the other hand, closes communication between said chamber 18 and connection 20.

Therefore, fluid under pressure from connection 22 is supplied to chamber B₁ of cylinder 26 and piston 28 is displaced against the action of spring 34.

Connection rod 30 of said piston is first displaced with its axis coincidental with the axis of cylinder 26. When the shaped end of said connecting rod reaches one of the faces of triangular lug 46, said connecting rod is misaligned and, clockwise rocked together with cup 32, is rocked clockwise and against the action of spring 34, due to the position assumed by lug 46.

The displacement of connecting rod 30 continues until the end of the latter reaches the bottom end 45 of lug 46 and further displacement of piston 28 provokes the oscillation counterclockwise of rocker 44 and slide 50. Piston 28, upon reaching the end of its stroke, is returned to its initial position, also because in the meantime the energization of the electromagnet A is interrupted, and valve 16 is returned to its initial position by means of spring 12; chamber B₁ is connected with the discharge, and spring 34 returns piston 28 and connecting rod 30 to the initial position and the latter, upon disengagement from lug 46 becomes aligned with the axis of piston 28.

Rocker 44, at the end of this operation, is arranged so that the apex of lug 46 is displaced relative to the axis of cylinder 26 at the side opposite the one considered, to reset thus the device for the next operation which occurs upon the re-energization of the electro-magnet A so that the end of connecting rod 30 engages the other face 45 of the triangular lug to return the rocker 44 to the position initially considered.

The oscillations of rocker 44 reciprocate slide 50 which has said notch 55 at the pushrod 57 and disengages notch 54 from pushrod 56. Therefore, connection 67 is connected with the discharge, while connection 66 is connected with connection 70 and, accordingly, with the source of compressed air.

The further operating movement impressed on rocker 44 returns member C to the initial position so as to revert again the supplying of the fluid operated apparatus to be actuated with a reciprocating movement depending on the communications which are established, from time to time, by the shut-off member C.

A complete embodiment of the device has been hereinbefore set forth; however, said embodiment may be subjected to modifications and variations, for example, piston 28 could be manually operated (that is, said piston may comprise a pushbutton which the operator depresses) or said piston can be directly operated by said

4

electromagnet A. Of course, other modifications and variations may be made, especially depending upon the characteristics of use of the device which may be incorporated in any fluid-operated apparatus, such as compressed air motors.

The aforementioned variations and modifications do not depart from the scope of the invention and, accordingly, from the scope of the patent.

We claim:

1. A device for commutatively controlling flow of fluids comprising a pivoted rocker member having a deflector thereon, a cylinder, a piston within said cylinder, a rod connecting with said piston, said rod being adapted to contact said deflector when said piston is actuated and be deflected alternately to one or another ends of said rocker member to move said rocker member about said pivot alternately in one or another direction, means for injecting fluid into said cylinder for actuating said piston, a slide member pivotally connected to one end of said rocker member and adapted to slide along a path to one position when said rocker member is moved in one direction and to another position when said rocker member is moved in another direction, a valve having a passage therein through which fluids may pass, and means responsive to the position of said slide for closing said passage when said slide is in said one position and opening said passage when said slide is in said other position.

2. A device as set forth in claim 1 wherein said means for injecting fluid includes a valve controlling flow of fluid to said cylinder, and electromagnetic means for opening and closing said valve.

3. A device as set forth in claim 1 wherein said rod is fitted with a cup and including a spring pressing said cup against said piston, whereby said rod is normally maintained axially of said cylinder but is permitted to move to one side upon contact with said deflector.

4. A device as set forth in claim 1 wherein said slide is mounted adjacent said cylinder and movable axially of said piston.

References Cited by the Examiner

UNITED STATES PATENTS

2,576,771	11/1951	Bentley	74—100 XR
2,867,235	1/1959	Hupp	137—636.1

FOREIGN PATENTS

581,313	8/1959	Canada.
1,180,445	6/1959	France.

M. CARY NELSON, *Primary Examiner*.

MARTIN P. SCHWADRON, *Examiner*.