

Sept. 1, 1964

E. LORETAN

3,146,582

SHOCK-ABSORBING BEARING FOR A MOVABLE WATCH OR CLOCK ELEMENT

Filed Nov. 14, 1962

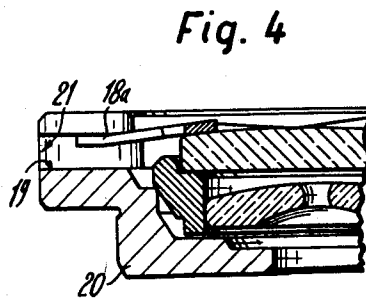
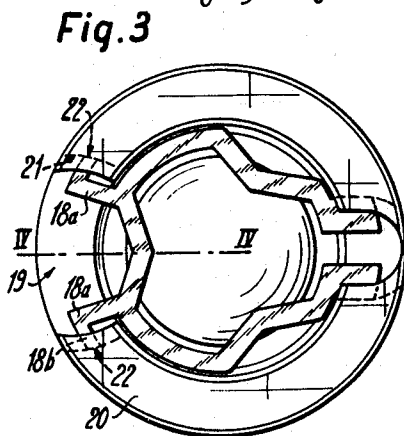
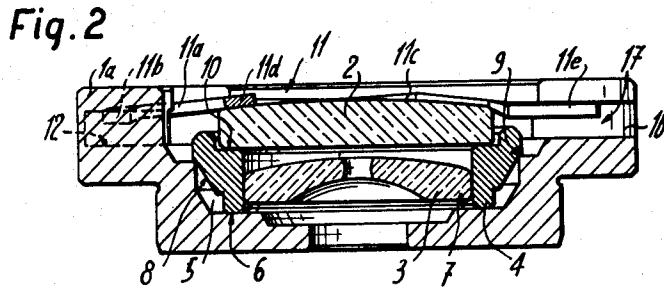
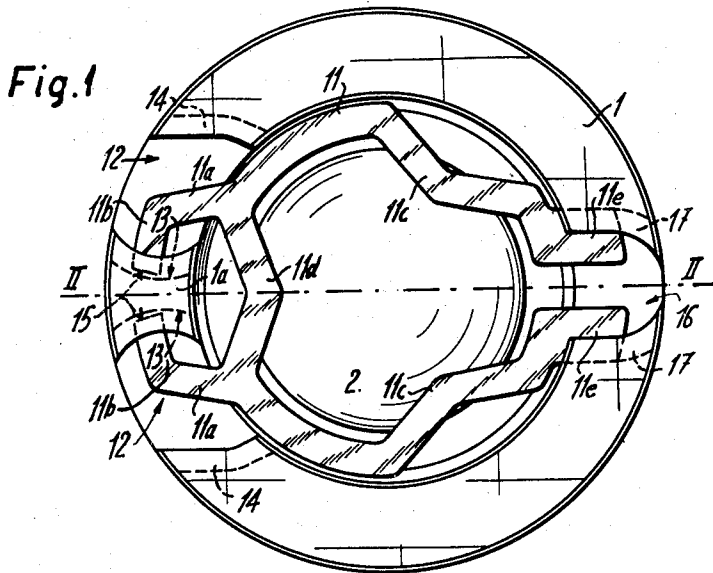

INVENTOR
EDOUARD LORETAN

1

2

3,146,582

SHOCK-ABSORBING BEARING FOR A MOVABLE WATCH OR CLOCK ELEMENT

Edouard Loretan, Le Sentier, Switzerland, assignor to Parechoc S.A., Le Sentier, Switzerland, a firm of Switzerland

Filed Nov. 14, 1962, Ser. No. 238,077

Claims priority, application Switzerland Nov. 29, 1961
13 Claims. (Cl. 58—140)

This invention relates to a shock-absorbing bearing for a movable watch or clock element, wherein a return spring acts on the bearing body to keep it in a centered position.

This bearing is characterized in that for the purpose of securing said spring adjacent the bearing support the said spring has a fork, the end of each arm of which is provided with a lateral pivot projection disposed in the general plane of the spring, said projections engaging in two recesses in the bearing support, the axes of which are disposed substantially perpendicularly to a diameter of the said support, the whole in such manner that the said spring is pivotally supported on the said support for movement between different angular positions in which the spring is self-supported.

The drawings illustrates two embodiments of the invention.

FIG. 1 is a plan view of a shock-absorbing bearing for a movable watch or clock element according to a first embodiment of the invention.

FIG. 2 is a section taken along line II—II in FIG. 1.

FIG. 3 is a plan view of an alternative embodiment of a shock-absorbing bearing for a movable watch or clock element and

FIG. 4 is a section taken along line IV—IV in FIG. 3.

The bearing shown in FIGS. 1 and 2 comprises a support 1 intended to be fitted into the plate of a watch or clock movement. A bearing body comprising an end-piece jewel 2 and a drilled jewel 3 surrounded by an in-setting 4 is housed inside the bearing support 1 in a recess 5 in the latter. The in-setting 4 has two centering surfaces, namely a plane front surface 6 co-operating with a plane seat 7 formed by the end of the recess 5 and a frusto-conical surface 8, co-operating with a circular ridge 9 formed by an inner shoulder of the support 1. The end-piece jewel 2 rests freely in a seat 10 with which the in-setting 4 is provided. It is held in place in the in-setting and the latter is held in the centered position in the support 1 by a return spring 11.

Said spring is mounted on the support 1. To this end it has a fork of which the two arms 11a are each bent at 11b so as to form a claw engaging a projection or web 1a of the support 1. Said web 1a is produced by forming two countersinks 12 in the outer annular surface of the support 1. The side surfaces of the projection 1a disposed opposite the ends 11b of the fork of the spring each have a groove 13, the end of which is shaped as an arc of a circle. Said grooves 13 are produced by the milling cutter used to produce the countersinks 12, this milling cutter being profiled. As a result the opposite edges of the countersinks 12 also have a groove of the same profile denoted by reference 14, which is of no special use but is a result of the production process. It should be noted that the end-faces 15 of the ends 11b of the spring situated opposite one another are inclined with respect to the central longitudinal plane of the spring to facilitate their introduction over the projection 1a. The spacing between the ends of the grooves 13 when viewed from the inside of the bearing is less than the distance separating the two surfaces 15 at the place where they are farthest apart. Thus the spring 11 only has to be pushed against the projection 1a and moved radially along the radius passing through the axis of the projection 1a to engage the

latter between the two arms 11a by resilient deformation of the latter. Once the spring is in position the ends 11b of its two arms 11a are engaged in the grooves 13. This assembly forms a spring articulation on the support 1 and enables the spring to be raised for dismantling of the bearing without the spring being able to become separated from the support.

The spring 11 also has two arms 11c forming a second spring diametrically opposite the first, which bear on the end-piece 2. A central part 11d forming a common base for the two forks of the spring also bears on the end-piece. The ends of the arms 11c denoted by reference 11e engage resiliently with the support 1. To this end the latter has a countersink 16 diametrically opposite the projection 1a, this countersink being produced with the same milling cutter as the countersinks 12, and the two opposite walls of said countersink 16 each have a groove 17. The ends 11e of the spring penetrate resiliently into these grooves and thus ensure that the spring is secured; the fork 11c simply has to be squeezed to free the ends 11e from the grooves 17 and release the spring 11 for free pivotal movement.

It should be noted that the pressure to which the fork 11c is subjected when its arms 11e are engaged in the grooves 17 tends to move the arms 11a of the articulation fork slightly apart so that the ends 11b are then free in the grooves 13 thus preventing the spring from being subjected to stresses which might produce undesirable bending. On the other hand, when the arms 11e are freed from the grooves 17 the articulation fork 11a closes up slightly so that the ends 11b press resiliently against the end of the grooves 13. The spring therefore remains in the position in which it has been placed, and does not of itself fall back onto the bearing, to form an obstacle to the watch or clock repairer for example.

The alternative embodiment shown in FIGS. 3 and 4 differs from the embodiment shown in FIGS. 1 and 2 in that the spring 18 has a fork, each of the two arms 18a of which is provided at the end with a projection 18b extending towards the outside of the fork and not the inside as in the embodiment shown in FIGS. 1 and 2. This fork is housed in a recess 19 formed in the outer annular surface of the support 20. The side surfaces of the recess 19 facing the projections 18b of the spring fork each have a groove 21, the end of which is shaped as an arc of a circle. These grooves 21 are produced by the same milling cutter used to produce the recess 19, the said milling cutter being profiled. It should be noted that the end surfaces 22 of the projection 18b on the spring are inclined with respect to the central longitudinal plane of the latter and this facilitates their introduction into the recess 19. The spacing between the ends of the grooves 21 when viewed from the inside of the bearing is less than the distance between the two surfaces 22 at the place where they are farthest apart. Thus, the fork 18a of the spring 18 simply has to be pushed into the recess 19 and displaced radially along the radius passing through the axis of the recess to cause the projections 18b to penetrate into the grooves 21 by resilient deformation of the arms 18a. This assembly forms a spring articulation on the support 20 to enable the spring to be lifted for dismantling of the bearing without the spring being able to be separated from the support by itself.

What I claim is:

1. A shock absorbing bearing for a timepiece comprising a support, a bearing body in said support and means detachably and pivotally supported on said support for removably securing the bearing body in the support, said means being constituted by a resilient spring member having opposite end portions, each of said end portions being constituted as a fork having opposed arms which are resiliently displaceable towards and away from one another,

3

said resilient member engaging said support with the forks at each of the end portions, said resilient spring member including a central arm adjacent one of the forks, the arms of the latter fork including projections in resilient engagement with the support for supporting the resilient member for self-supporting pivotal movement when the arms of the other of the forks are released from the support, said arms of the other of said forks being releaseable from the support solely by displacement of the arms relative to one another.

2. A bearing as claimed in claim 1 wherein said support is provided with arcuate recesses, the projections of the arms of the said one fork having straight ends accommodated in said recesses in resilient engagement with the support which thereby resists removal of the projections from the recesses.

3. In a shock absorbing bearing for a timepiece: a circular support, a bearing body in the support and a return spring member supported on the support and acting on the bearing body to keep the same in a centered position, said spring member including a pair of connected arms defining a plane of symmetry for said spring member, said arms having opposed ends which define forks at each of the ends of the spring member and whereat the arms can be displaced towards and away from one another, a lateral projection on each arm at one of the forks, the projections lying in a common plane, said support being provided with two recesses each of which accommodates a corresponding projection of the arms of the said one fork with the projections in contact with the support, said recesses being arcuate and extending substantially radially, said projections have straight ends which are inclined with respect to said plane of symmetry, said projections extending into the recesses substantially perpendicularly such that the spring member is pivotally secured to the said support by said one fork and is self-supporting in different angular positions of the spring member in the support.

4. In a bearing as claimed in claim 3 wherein said projections extend towards one another.

5. In a bearing as claimed in claim 4 wherein said support includes an annular portion which is provided with spaced countersinks defining a web therebetween as well as said recesses which are undercut in said web, said ends of the projections on the arms of the fork extending into said arcuate recesses into contact with the web thus formed in the annular portion.

6. In a bearing as claimed in claim 3 wherein said support is provided with a further pair of recesses at a location diametrically opposed to the location at which the projections of said one fork are engaged in the first mentioned recesses, said arms being resiliently engaged in the

4

further recesses and being detachable therefrom by resilient deformation of the arms towards one another, said projections remaining in contact with the support with the arms detached from the support at said further pair of recesses.

7. In a bearing as claimed in claim 3 wherein said spring member includes a central arm connecting the first mentioned arms at a location adjacent the said one fork, said spring member being adapted for engaging the bearing body with the central arm and with the other arms at a location between the central arm and the other of said forks.

8. In a bearing as claimed in claim 3 wherein said projections extend away from one another.

9. In a bearing as claimed in claim 5 wherein said ends of the projections are spaced apart at the location of maximum spacing a distance which is greater than the distance between the recesses at one of the ends of the web thereby facilitating insertion of the projections into the recesses for resilient engagement with the projection.

10. A return spring adapted for being secured in a bearing support to act on a bearing body to hold the same in said support, said spring being constituted of resilient material and including a pair of spaced symmetrical arms defining a central longitudinal plane of symmetry for said spring, said spring having opposite end portions each constituted as a fork, said spring further including a transverse portion extending between said arms to connect the same together at a location adjacent one of the forks whereby the free ends of the arms at both of the forks will be resiliently displaceable towards and away from one another while the degree of flexibility of the arms at the fork closer to said transverse portion will be reduced when compared to that of the arms at the other of the forks, said spring further including a pair of projections for said one fork extending from the free ends of the arms in a direction having a component perpendicular to the central longitudinal plane.

11. A spring as claimed in claim 10 wherein said projections have ends which are straight and which are inclined with respect to said longitudinal plane.

12. A spring as claimed in claim 10 wherein said projections extend away from one another.

13. A spring as claimed in claim 10 wherein said projections extend towards one another.

References Cited in the file of this patent

UNITED STATES PATENTS

2,746,239 Vuilleumier ----- May 22, 1956

FOREIGN PATENTS

343,318 Switzerland ----- Dec. 15, 1959