



May 13, 1930.

C. FENSKY ET AL  
AUTOMATIC SPACER

1,758,657

Filed Dec. 28, 1928

2 Sheets-Sheet 2

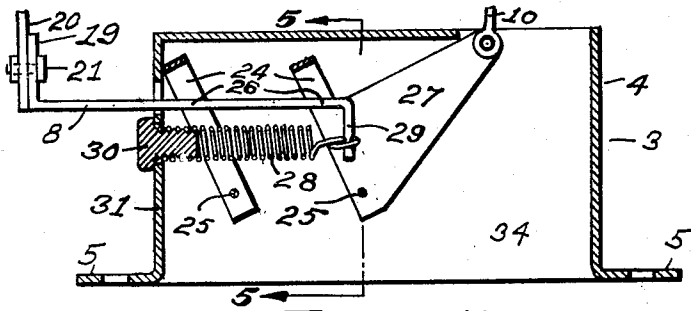

*Fig. 4.*

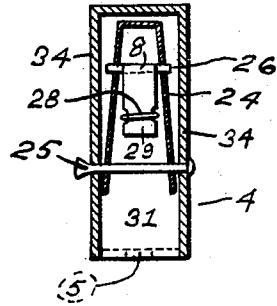

*Fig. 5.*

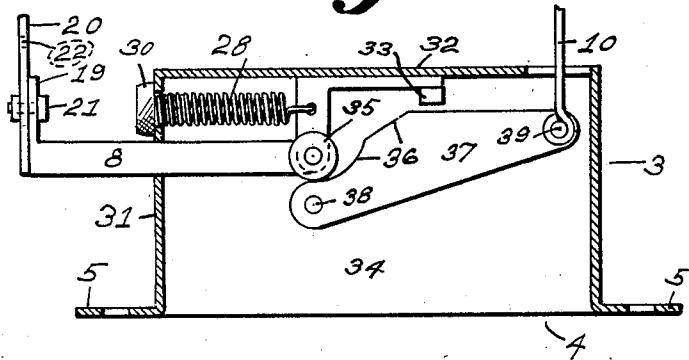

*Fig. 6.*

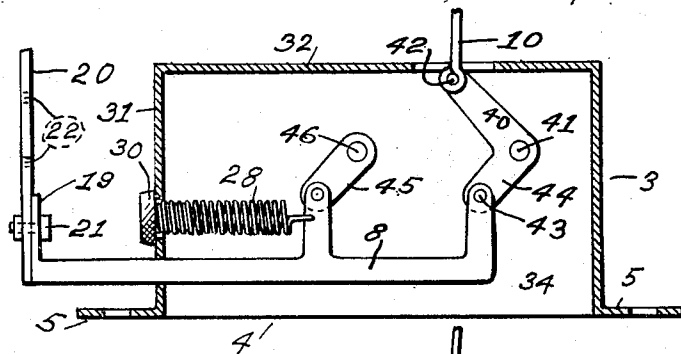

*Fig. 7.*

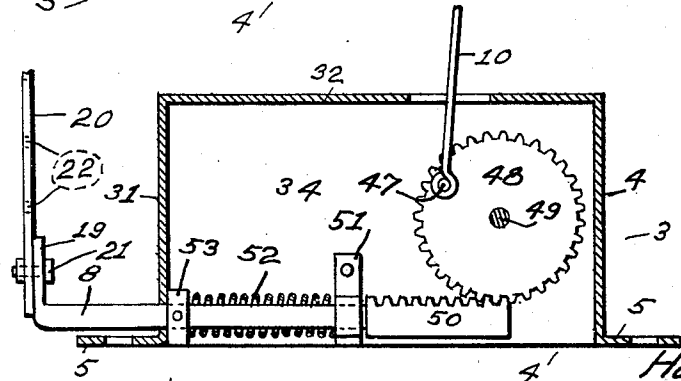

*Fig. 8.*

INVENTORS:  
Charles Fensky,  
Harvey J. Readey,  
BY Hugh H. Magner,  
ATTORNEY.

# UNITED STATES PATENT OFFICE

CHARLES FENSKY AND HARVEY J. READEY, OF ST. LOUIS, MISSOURI; ANNA K.  
READEY ADMINISTRATRIX OF SAID HARVEY J. READEY, DECEASED

## AUTOMATIC SPACER

Application filed December 28, 1928. Serial No. 328,956.

This invention relates to automatic means for operating copy-holders and is particularly applicable to a copy-holder of the type described and claimed by the same inventors in their prior application for patent, Serial No. 321,533, filed November 24, 1928. The copy-holder referred to is positioned in convenient proximity to the operator of a typewriter and embodies a line-indicating rule or guide that is lowered after a line has been copied in order to indicate the following line. The lowering of the guide is effected manually by the operator's depression of a lever; and the present invention aims to provide means whereby the depression of the lever is effected automatically by the movement of the typewriter carriage.

In the accompanying drawings forming part of this specification, in which like numbers of reference denote like parts wherever they occur,

Figure 1 is a front elevation exhibiting the device of this invention assembled in operative relation to a typewriter and copy-holder;

Figure 2 is a side elevation of the same;

Figure 3 is a plan view of the assembly;

Figure 4 is a vertical longitudinal central sectional view of one form of the device;

Figure 5 is a transverse sectional view of this form taken on the line 5—5 of Figure 4; and

Figures 6, 7 and 8 are vertical longitudinal central sectional views of divers other forms of the invention, selected as illustrative merely, and not in a limiting sense.

In the particular illustrative assembly of the operating device with the typewriter and copy-holder as herein shown, the copy-holder 1 is positioned immediately behind and slightly to the right of the typewriter 2; and the automatic operating device 3 is positioned at the right of the typewriter 2 and in front of the copy-holder 1. The device 3 preferably comprises a housing or other suitable enclosing frame 4, having lugs 5, apertured to receive screws or bolts 6, by means of which the housing may be secured to the typewriter table or desk 7 or a suitable plate underlying the assembled devices. The housing 4 en-

closes a horizontal rod 8 that is adapted to reciprocate in the direction of movement of the typewriter carriage 9, that is from left to right and the reverse, as shown in Figure 1. The rod 8 operates a rotary member that effects a substantially vertical reciprocation of a link 10, whose upper end is flexibly or pivotally connected to the outer end of copy-holder operating lever 11, preferably, though not necessarily, through the intermediation of a contractile coil spring 12. The depression of lever 11 operates ratchet wheel 13, that, through shaft 14, operates conveyor 15, that bears projections 16, that carry the line-indicating rule 17. The function of spring 12, which must be stronger than the spring 18 of the copy-holder that maintains lever 11 in its elevated position, is to enable link 10 to move through a greater distance than that permitted by the stroke of the lever 11, and thereby to compensate automatically for inaccuracies and to allow latitude in the connection of the device 3 to the lever 11 through the link 10. Rod 8 is provided with an upturned outer end 19, and a vertical bar 20 is adjustably secured on the end 19 through a bolt 21, passing through an aperture in the end 19 and any one of a series of alternative apertures 22 in the bar 20. Spring means are preferably employed to shift the rod 8 toward the left, so that the carriage need move the bar only toward the right, that is, on its return movement, the bar 20 being adjusted so that it acts as a target arranged in the path of any suitable part or projection of the typewriter carriage and is thereby pushed toward the right by such part or projection of the carriage at or near the end of the return movement of the latter. The said spring means, of course, must be strong enough to move the rod 8 toward the left against the opposition of springs 12 and 18. The portion of the rod 20 engaged by the carriage is provided with a rubber pad or bumper 23 to eliminate noise.

Referring now more particularly to the specific form of operating device shown in Figures 4 and 5, the rod 8 is confined to a translational movement by a parallel motion mechanism comprising parallel straddling

substantially upright U-shaped levers 24, pivoted at 25 to the casing 4, and at 26 to the rod 8. The lever 24 toward the right is formed with an extension or arm 27, whose outer end is pivoted to the lower end of the link 10, said arm 27 constituting one form of the rotary member of the device 3 hereinbefore referred to. The spring means employed to shift the rod 8 to the left in this specific form of the device consists of a contractile helical spring 28, one end of which is secured to a depending extension 29 on the inner end of the rod 8, and the other end of which fits the thread of a screw 30, extending through an aperture in the left wall 31 of the casing 4.

The form of the device 3 shown in Figure 6 comprises a substantially Z-shaped rod 8, one end of which is guided in an aperture of the left wall 31 of the casing, and the other end of which is guided between the top wall 32 of the casing 4 and a projection 33 on the inner side of the lateral wall 34 of the casing. Rod 8 bears an anti-friction roller 35 that engages the upper edge 36 of rotary lever 37, pivoted to the casing at 38, and to link 10 at 39. The edge 36 is preferably so shaped that any excess inward movement of rod 8 will not produce a further depression of lever 37.

Figure 7 exhibits a device 3 having a bell-crank shaped rotary member 40, pivoted to the casing at 41 and to the link 10 at 42. The rod 8 is restricted to a translational movement by being pivoted at 43 to the lower arm 44 of member 40, and to a parallel lever 45, pivoted to the casing at 46.

Figure 8 illustrates a rack and gear method of converting the horizontal reciprocatory motion of the rod 8 into the vertical reciprocatory motion of the link 10, the link 10 being pivoted at 47 to the gear 48, journaled on a pin 49 borne by the casing 4. Rack 50 is constrained to a longitudinal movement by a bracket 51 on the wall 34 and by the aperture in the wall 31 through which it passes, the rod 8 of the rack being preferably rectangular in cross-section and the aperture and bracket being likewise rectangular to fit the rod. An expansile spring 52 is coiled around the rod 8 between the bracket 51 and a collar 53 affixed to the rod 8.

It will be observed that, as the carriage 9 of the typewriter nears the end of its step-by-step movement to the right, it engages the pad 23 and moves arm 8 of device 3 to the right against the opposition of the three springs 12, 18, and 28, and, through the intermediation of the mechanism of the device 3, pulls link 10 down and depresses lever 11 until the carriage arrives at its extreme position toward the right, when lever 11 will have been depressed the full extent of its stroke and bar 17 will have been lowered to indicate the succeeding line to be copied from the original on the copy-holder. When the end of a line has been reached, the operator shifts

the typewriter carriage back toward its extreme left position, thereby allowing rod 8 to be returned to its initial position under the impulsion of springs, as 28 or 52, after which the foregoing cycle of operations may be re-enacted. If desired, the walls 34 of the casing 4 may be extended to the left and be provided with flanges 54 by means of which it may be secured to the side wall of the typewriter, as shown in broken lines in Figure 1.

Having thus fully described this invention, we hereby reserve the benefit of all changes in form, arrangement, order, or use of parts, as it is evident that many minor changes may be made therein without departing from the spirit of this invention or the scope of the following claims.

We claim:

1. The combination, with a copy-holder having relatively shiftable line-indicating means and a lever for shifting said means, of a device adapted to be secured in juxtaposition to a typewriter and embodying a member arranged in the path of the typewriter carriage so as to be shifted as said carriage nears the end of its movement to the right, and a connection between said device and said lever, whereby said member actuates said lever through the intermediation of said device.

2. The combination with a copy-holder having relatively shiftable line-indicating means and a substantially vertically movable lever for shifting said means, of a device adapted to be secured in juxtaposition to a typewriter and embodying a member arranged in the path of the typewriter carriage so as to be shifted substantially horizontally as the latter nears the end of its step-by-step movement to the right, and a connection between said device and said lever, the arrangement being such that said device converts the horizontal movement of said member into the vertical movement of said lever.

3. The combination, with a copy-holder having relatively shiftable line-indicating means and a lever for shifting said means, of a device adapted to be juxtaposed to a typewriter and embodying a member arranged in the path of the typewriter carriage so as to be shifted by the movement of the latter, and an automatically adjustable connection between said device and said lever, whereby said member actuates said lever through the intermediation of said device.

4. The combination, with a copyholder having relatively shiftable line-indicating means and a lever for shifting said means, of a device adapted to be juxtaposed to a typewriter and embodying a target arranged in the path of the typewriter carriage and adjustable transversely thereto and a connection between said device and said lever, whereby the target actuates said lever through the intervention of said device.

5. A copy-holder having relatively shiftable line-indicating means and a lever for shifting said means, and a device adapted to be juxtaposed to a typewriter and embodying a member arranged in the path of the typewriter carriage so as to be shifted by the movement of the latter, said device further including a frame, a member translationally borne thereby, a member rotatively borne by said frame and operated by the translationally movable member and means connected to said rotary member for operating the copy-holder lever.

6. A copy-holder having relatively shiftable line-indicating means and a lever for shifting said means, and a device for operating said lever and adapted to be operated itself by a typewriter carriage as the same nears the end of its movement, said device including a frame, a pair of members borne thereby and adapted to be oscillated in unison, means for oscillating said members as the carriage nears the end of its movement to the right and a reciprocatory link connecting one of said members and the copy-holder lever for shifting the line-indicating means.

7. A copy-holder having relatively shiftable line-indicating means and a lever for shifting said means, and a device for operating said lever and adapted to be operated itself by a typewriter carriage as the same nears the end of its movement, said device including a frame, a member rotatively borne by said frame, means for rotating said member as the carriage nears the end of its step-by-step movement, a link connected to said member and said lever for operating the line-indicating means of said copy-holder and spring means normally maintaining said member in one of its extreme positions.

8. A copy-holder having relatively shiftable line-indicating means and a lever for shifting said means, and a device for operating said lever and adapted to be operated itself by a typewriter carriage as the same nears the end of its step-by-step movement, said device including a reciprocating member operated by said carriage, a rotary member operated by said reciprocating member, a second reciprocating member connected to said rotary member and adapted to operate the lever for shifting said line-indicating means, a tension device interposed between the connection of said second-named reciprocating member and spring means for normally maintaining said rotary member in one of its extreme positions.

In testimony whereof we hereunto affix our signatures.

CHARLES FENSKY.  
HARVEY J. READEY.