

CORRECTED VERSION

(19) World Intellectual Property Organization  
International Bureau



(10) International Publication Number  
**WO 2024/250145 A9**

(43) International Publication Date  
12 December 2024 (12.12.2024)

(51) International Patent Classification:

*B32B 5/06* (2006.01)      *B32B 5/02* (2006.01)  
*B32B 7/09* (2019.01)      *A41D 31/18* (2019.01)  
*B32B 5/26* (2006.01)      *D06J 1/00* (2006.01)

pu, Shanghai, 200438 (CN). **KOSHKAROFF, Iustinia**; c/o Nike, Inc., One Bowerman Drive, Beaverton, OR 97005 (US).

(21) International Application Number:

PCT/CN2023/098315

(74) Agent: **AFD CHINA INTELLECTUAL PROPERTY LAW OFFICE**; Tower B, 21st Fl. Suite 2108, 38 Xueqing Road, Haidian District, Beijing 100083 (CN).

(22) International Filing Date:

05 June 2023 (05.06.2023)

(81) Designated States (unless otherwise indicated, for every kind of national protection available): AE, AG, AL, AM, AO, AT, AU, AZ, BA, BB, BG, BH, BN, BR, BW, BY, BZ, CA, CH, CL, CN, CO, CR, CU, CV, CZ, DE, DJ, DK, DM, DO, DZ, EC, EE, EG, ES, FI, GB, GD, GE, GH, GM, GT, HN, HR, HU, ID, IL, IN, IQ, IR, IS, IT, JM, JO, JP, KE, KG, KH, KN, KP, KR, KW, KZ, LA, LC, LK, LR, LS, LU, LY, MA, MD, MG, MK, MN, MU, MW, MX, MY, MZ, NA, NG, NI, NO, NZ, OM, PA, PE, PG, PH, PL, PT, QA, RO, RS, RU, RW, SA, SC, SD, SE, SG, SK, SL, ST, SV, SY, TH, TJ, TM, TN, TR, TT, TZ, UA, UG, US, UZ, VC, VN, WS, ZA, ZM, ZW.

(25) Filing Language:

English

(26) Publication Language:

English

(71) Applicant (for all designated States except US): **NIKE INNOVATE C.V.** [NL/US]; One Bowerman Drive, Beaverton, Oregon 97005 (US).

(71) Applicant (for US only): **NIKE, INC.** [US/US]; One Bowerman Drive, Beaverton, Oregon 97005 (US).

(72) Inventors: **STAUB, Andrea J.**; c/o NIKE, Inc., One Bowerman Drive, Beaverton, Oregon 97005 (US). **ZHU, Xiaojun**; c/o Nike Sourcing (Guangzhou) Co., Ltd., Yangpu Branch, Building 1, No. 99 Jiangwancheng Road, Yang-

(84) Designated States (unless otherwise indicated, for every kind of regional protection available): ARIPO (BW, CV, GH, GM, KE, LR, LS, MW, MZ, NA, RW, SC, SD, SL, ST,

(54) Title: PLEAT CONSTRUCTION FOR COMPOSITE NONWOVEN TEXTILE SUITABLE FOR WEARABLE ARTICLES AND METHODS OF MANUFACTURING THE SAME

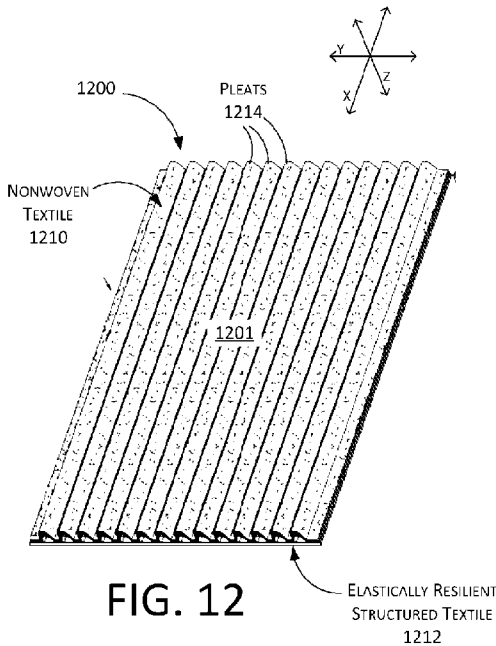

(57) Abstract: A pleated construction suitable for wearable articles comprises a nonwoven textile and an elastically resilient structured textile connected by at least two rows of stitches. The nonwoven textile extends in a z-direction away from the elastically resilient structured textile between the at least two rows of stitches.



WO 2024/250145 A9

SZ, TZ, UG, ZM, ZW), Eurasian (AM, AZ, BY, KG, KZ, RU, TJ, TM), European (AL, AT, BE, BG, CH, CY, CZ, DE, DK, EE, ES, FI, FR, GB, GR, HR, HU, IE, IS, IT, LT, LU, LV, MC, ME, MK, MT, NL, NO, PL, PT, RO, RS, SE, SI, SK, SM, TR), OAPI (BF, BJ, CF, CG, CI, CM, GA, GN, GQ, GW, KM, ML, MR, NE, SN, TD, TG).

**Published:**

- *with international search report (Art. 21(3))*
- *with information concerning authorization of rectification of an obvious mistake under Rule 91.3 (b) (Rule 48.2(i))*

**(48) Date of publication of this corrected version:**

06 March 2025 (06.03.2025)

**(15) Information about Correction:**

see Notice of 06 March 2025 (06.03.2025)

## Description

### **Title of Invention: PLEAT CONSTRUCTION FOR COMPOSITE NONWOVEN TEXTILE SUITABLE FOR WEARABLE ARTICLES AND METHODS OF MANUFACTURING THE SAME**

Rule 91,  
07.02.2025

#### **FIELD OF THE INVENTION**

[0001] This disclosure describes a recyclable, composite nonwoven textile with pleated construction suitable for wearable articles and other articles and methods for producing the same.

#### **BACKGROUND OF THE INVENTION**

[0002] Traditional nonwoven textiles have features that are generally not suitable for use in articles of apparel. Due to these features, as well as end uses in, for example, the cleaning industry and the personal hygiene industry, traditional nonwoven textiles can be incompatible with finishing processes and techniques that are commonly utilized in connection with knit and/or woven textiles. As a result, traditional nonwoven textiles typically lack aesthetically pleasing and/or functional features that are desirable in articles of apparel.

[0003] BRIEF DESCRIPTION OF THE DRAWING

[0004] Examples of aspects herein are described in detail below with reference to the attached drawing figures, wherein:

[0005] FIG. 1 illustrates an example lifecycle for an example composite nonwoven textile in accordance with aspects herein;

[0006] FIG. 2 illustrates a first web of fibers for use in the example composite nonwoven textile of FIG. 1 in accordance with aspects herein;

[0007] FIG. 3 illustrates a second web of fibers for use in the example composite nonwoven textile of FIG. 1 in accordance with aspects herein;

[0008] FIG. 4 illustrates a third web of fibers for use in the example composite nonwoven textile of FIG. 1 in accordance with aspects herein;

[0009] FIG. 5 illustrates an elastomeric layer for use in the example composite nonwoven textile of FIG. 1 in accordance with aspects herein;

[0010] FIG. 6 illustrates an example manufacturing process for use in making the example composite nonwoven textile of FIG. 1 in accordance with aspects herein;

[0011] FIG. 7 illustrates a first face of the example composite nonwoven textile of FIG. 1 in accordance with aspects herein;

- [0012] FIG. 8 illustrates an opposite second face of the example composite nonwoven textile of FIG. 1 in accordance with aspects herein;
- [0013] FIG. 9 illustrates a cross-section view of the example composite nonwoven textile of FIG. 7 in accordance with aspects herein;
- [0014] FIG. 10 illustrates a cross-section view of an alternative construction for the example composite nonwoven textile in accordance with aspects herein;
- [0015] FIG. 11 illustrates the cross-section view of FIG. 9 depicting only silicone-coated fibers in accordance with aspects herein;
- [0016] FIG. 12 illustrates a first outer facing side of an example pleated construction in accordance with aspects herein;
- [0017] FIG. 13 illustrates a second outer facing side of the example pleated construction of FIG. 12 in accordance with aspects herein;
- [0018] FIG. 14 illustrates an example manufacturing process for use in making in forming the pleated construction of FIG. 12 and for further use in making an apparel item using the pleated construction of 12 in accordance with aspects herein;
- [0019] FIG. 15 illustrates an example stitching machine with the nonwoven textile and elastically resilient structured textile material layer loaded on the machine;
- [0020] FIGS 16 and 17 illustrate rows of stitches applied to the nonwoven textile and elastically resilient structured textile material layer;
- [0021] FIG. 18 illustrates a pleat construction; and
- [0022] FIG. 19 illustrates a pleat construction forming a portion of a wearable article.

## **DETAILED DESCRIPTION OF THE INVENTION**

- [0023] This specification describes a pleating construction for a nonwoven textile that is sustainable and that provides a pleasing finish. For example, the pleat construction can include lower amounts of adhesive or other less recyclable materials as compared with conventional pleat constructions. In some instances, the pleat can include at least one nonwoven material textile layer, an elastically resilient structured textile material layer (e.g., power mesh), and a series of stitches (e.g., running stitch or other linear arrangement of stitches) in rows that connect the at least one nonwoven material textile layer to the elastomeric layer. For example, to construct the pleat, the elastically resilient structured textile material layer can be positioned next to the nonwoven textile layer and stretched (e.g., stretched in the machine direction). Then, with the elastically resilient structured textile material layer under tension, the series of stitches in rows can be applied. After the series of stitches in rows are applied (e.g., in a serpentine-line pattern), the tension applied to the elastically resilient structured textile material layer can be released, which draws together the rows of stitches and causes the nonwoven

material textile layer to protrude outward, away from the elastically resilient structured textile material layer, and in a rib-like manner.

- [0024] Some conventional approaches can apply heat, adhesives, chemicals, and/or other components to form pleats; however, these approaches can suffer from various drawbacks. For example, heat alone can be insufficient to hold a pleat for longer periods of time. In addition, chemicals and adhesives can cause the underlying textile to be less sustainable (e.g., less recyclable due to contamination) and/or can require larger amounts of energy to create the pleat. Further, these can negatively impact the hand-feel of the pleat structure and/or can result in a pleat that is too stiff. In contrast, the pleat construction of the present disclosure is more sustainable based on not contaminating the underlying textile and by using less energy to execute. In addition, the pleat construction of the present disclosure provides a pleasing aesthetic and a good hand-feel.
- [0025] Aspects herein further contemplate that the nonwoven textile is recyclable, and in some aspects, the textile may be fully recyclable. Thus, in aspects, the fibers or filaments selected to form the nonwoven textile can include recycled materials, including recycled polymers and/or recycled thermopolymers. Additionally, materials selected to form other parts of the pleat, such as the stitches and the elastically resilient structured textile material layer may also be fully recyclable. Use of recycled fibers and materials reduces the carbon footprint of the composite nonwoven textile.
- [0026] As used herein, the term “article of apparel” is intended to encompass articles worn by a wearer, which can also be referred to as “wearable articles”. Wearable articles can include, among other things, upper-body garments (e.g., tops, t-shirts, pullovers, hoodies, jackets, coats, vests, and the like), lower-body garments (e.g., pants, shorts, tights, capris, unitards, and the like), hats, gloves, sleeves (e.g., arm sleeves, calf sleeves), articles of footwear (e.g., uppers for shoes), and the like. As used herein, the term “finished goods” may include articles of apparel or wearable articles, equipment such as bags, furniture, and other such items. As used herein, the term “roll goods” may include, for example, rolls of textile, scraps or remnants remaining after pieces are cut from rolls, and the like.
- [0027] The term “inner-facing surface” when referring to the wearable article means the surface that is configured to face mostly towards a body surface of a wearer, and the term “outer-facing surface” means the surface that is configured to substantially face away from the body surface of the wearer and toward an external environment. The term “innermost-facing surface” means the surface closest to the body surface of the wearer with respect to other layers of the wearable article, and the term “outermost-facing surface” means the surface that is positioned furthest away from the body surface of the wearer with respect to the other layers of the wearable article.

- [0028] As used herein, the term “nonwoven textile” refers to a textile having fibers or filaments that are held together by mechanical and/or chemical interactions without being in the form of a knit, woven, braided construction, or other structured construction. In a particular aspect, the nonwoven textile includes a collection of fibers or filaments that are mechanically manipulated to form a mat-like material. Stated differently nonwoven textiles are directly made from fibers or filaments. The nonwoven textile may include different webs of fibers formed into a cohesive structure, where the different webs of fibers may have a different or similar composition of fibers and/or different properties. Examples of nonwoven textiles can include a fiber web formed with staple fibers, spun-bonded textile, spunlace textile, melt-blown textile, and the like, and any and all combinations thereof.
- [0029] The term “web of fibers” or “fiber web” refers to a layer of fibers prior to undergoing a mechanical entanglement process with one or more other webs of fibers. The web of fibers includes fibers that have undergone a carding and lapping process that generally aligns the fibers in one or more common directions that extend along an x, y plane and that achieves a desired basis weight. The web of fibers may also undergo a light needling process or mechanical entanglement process that entangles the fibers of the web to a degree such that the web of fibers forms a cohesive structure that can be manipulated (e.g., rolled on to a roller, un-rolled from the roller, stacked, and the like) . In examples, a “fiber-web roll good” refers to fibers that have been formed into a cohesive structure (e.g., by carding, lapping, and/or light needling) and rolled onto a core. The web of fibers may also undergo one or more additional processing steps such as printing prior to being entangled with other webs of fibers to form the composite nonwoven textile. The term “entangled web of fibers” when referring to the composite nonwoven textile refers to a web of fibers after it has undergone mechanical entanglement (e.g., needled, water entangled, air entangled, etc. ) with one or more other webs of fibers. As such, a web of entangled fibers may include fibers originally present in the web of fibers forming the layer as well as fibers that are present in other webs of fibers that have been moved through the entanglement process into the web of entangled fibers.
- [0030] Mechanical entanglement processes contemplated herein can include needle entanglement (commonly known as needlepunching) using barbed or structured needles (e.g., forked needles) , and/or fluid entanglement. In aspects contemplated herein, needlepunching may be utilized based on the small denier of the fibers being used and the ability to fine tune different parameters associated with the needlepunching process. Needlepunching generally uses barbed or spiked needles to reposition a percentage of fibers from a generally horizontal orientation (an orientation extending along an x, y plane) to a generally vertical orientation (az-direction orientation) .

Referring to the needlepunching process in general, the carded, lapped, and pre-needled webs may be stacked with other carded, lapped, and pre-needled webs and other layers such as an elastomeric layer and passed between a bed plate and a stripper plate positioned on opposing sides of the stacked web configuration.

- [0031] Barbed needles, which are fixed to a needle board, pass in and out through the stacked web configuration, and the stripper plate strips the fibers from the needles after the needles have moved in and out of the stacked web configuration. The distance between the stripper plate and the bed plate may be adjusted to control web compression during needling. The needle board repeatedly engages and disengages from the stacked web configuration as the stacked web configuration is moved in a machine direction along a conveyance system such that the length of the stacked web configuration is needed.
- [0032] Aspects herein contemplate using multiple needle boards sequentially positioned at different points along the conveyance system where different needle boards may engage the stacked web configuration from different faces of the stacked web configuration (e.g., an upper face and a lower face) as the stacked web configuration moves in the machine direction. Each engagement of a needle board with the stacked web configuration is known herein as a “pass.”
- [0033] Parameters associated with particular needle boards may be adjusted to achieve desired properties of the resulting needled nonwoven textile (e.g., basis weight, thickness, and the like). The different parameters may include stitch density (SD) which is the number of needles per  $\text{cm}^2$  ( $\text{n}/\text{cm}^2$ ) used during an entanglement pass and penetration depth (PD) which is how far the needle passes through the stacked web configuration before being pulled out of the stacked web configuration. Parameters associated with the needlepunching process in general may also be adjusted such as the spacing between the bed plate and the stripper plate and/or the speed of conveyance of the stacked web configuration.
- [0034] Examples of this disclosure contemplate using a barbed needle (a needle having a pre-set number of barbs arranged along a length of the needle) although other needle types are contemplated herein. The barbs on the needle “capture” fibers as the barb moves from a first face to an opposing second face of the stacked web configuration. The movement of the needle through the stacked web configuration effectively moves or pushes fibers captured by the barbs from a location near or at the first face to a location near or at the second face and further causes physical interactions with other fibers helping to “lock” the moved fibers into place through, for example, friction.
- [0035] It is also contemplated herein that the needles may pass through the stacked web configuration from the second face toward the first face. In example aspects, the number of barbs on the needle that interact with fibers may be based on the penetration depth

of the needle. For example, all the barbs may interact with fibers when the penetration depth is a first amount, and fewer than all the barbs may interact with fibers as the penetration depth decreases.

- [0036] In further example aspects, the size of the barb may be adjusted based on the denier of fibers used in the web (s). For example, the barb size may be selected so as to engage with small denier (e.g. fine) fibers but not with large denier fibers so as to cause selective movement of the small denier fibers but not the large denier fibers. In another example, the barb size may be selected so as to engage with both small denier and large denier fibers so as to cause movements of both fibers through the webs.
- [0037] After entanglement, the nonwoven textile may include a first face and an opposite second face which both face outward with respect to an interior of the nonwoven textile and comprise the outermost faces of the nonwoven textile. As such, when viewing the nonwoven textile, the first face and the second face are each fully visible. The first face and the second face may both extend along x, y planes that are generally parallel and offset from each other. For instance, the first face may be oriented in a first x, y plane and the second face may be oriented in a second x, y plane generally parallel to and offset from the first x, y plane.
- [0038] The term “elastomeric layer” as used herein refers to a layer that has stretch and recovery properties (e.g., is elastically resilient) in at least one orientational axis, which includes both a layer having stretch and recovery in a single orientational axis and a layer having stretch and recovery in multiple orientational axes. Examples of an orientational axis include a length direction, a width direction, an x-direction, a y-direction, and any direction angularly offset from a length direction, a width direction, an x-direction, and a y-direction.
- [0039] The elastomeric layer may be formed from thermoplastic elastomers such as thermoplastic polyurethane (TPU), thermoplastic polyether ester elastomer (TPEE), combinations of TPU and TPEE and the like. The elastomeric layer may comprise a spunbond layer, a meltblown layer, a film, a web, a scrim, and the like. In example aspects, the elastomeric layer may include a spunbond TPEE or a meltblown TPU. Nonwoven elastomeric materials such as a spunbond TPEE or a meltblown TPU allow for lower basis weights than elastomeric films. As well, they are generally more breathable and permeable due to the fibrous nature of the web versus a film, and they are generally more pliable (e.g., less stiff) than films. These factors (low basis weight, breathable and permeable, pliable) make them ideal for use in the example composite nonwoven textile described herein especially in the apparel context where these are desirable features.
- [0040] When referring to fibers, the term denier or denier per fiber is a unit of measure for the linear mass density of the fiber and more particularly, it is the mass in grams per

9000 meters of the fiber. In one example aspect, the denier of a fiber may be measured using ASTM D1577-07. The diameter of a fiber may be calculated based on the fiber's denier and the fiber's density, and in general, the diameter of a fiber has a direct correlation to the denier of the fiber (i.e., a smaller denier fiber has a smaller diameter) .

[0041] Fibers contemplated herein may be formed of a number of different materials (e.g., cotton, nylon and the like) including polyester, such as polyethylene terephthalate (PET) . The fibers may include virgin fibers (fibers that have not been recycled) , and/or recycled fibers. Recycled fibers include “shredded-article fibers” and “re-pelletized-polymer fibers. ” As used herein, shredded-article fibers include fibers that are direct by-products of shredding a fiber-containing article (e.g., knit, woven, nonwoven, etc. ) . In some examples, shredded-article fibers may be derived without pelletizing and extrusion through processes that consume less energy, and as such, textiles that incorporate shredded-article fibers may have a lower carbon footprint. Re-pelletized-polymer fibers include fibers that are extruded from pelletized or chipped by-products derived from polymer-containing sources (e.g., polymer-containing bottles or containers; polymer-fiber articles that are knit, woven, nonwoven; roll goods; textile manufacturing scrap; fiber webs at various stages of carding, lapping, pre-needling, and needling; etc. ) . In some examples, the fibers can be monofilament, bicomponent, or multicomponent. In some examples, a multicomponent fiber can include side-by-side, sheath core, pie, striped, islands-in-a-sea, and various other configurations. In addition, a fiber can include various cross-section profiles, such as circular, ovular, flat, trilobal, squared, rectangular, polygonal, etc.

[0042] The term “silicone-coated fiber” as used herein may mean a fiber having a continuous silicone coating such that the silicone coating completely covers the fiber along its length. In one example, the fiber may form a core and the silicone may form a sheath surrounding the core. In other example aspects, the term “silicone-coated fiber” may mean a fiber that has an intermittent coating of silicone in at least some areas along the length of the fiber. For instance, the fiber may be sprayed with a silicone coating. In this aspect, if a particular web of fibers includes 100%by weight of silicone-coated fibers, it is contemplated herein that the fibers that form the web may have areas that do not include the silicone coating. It is contemplated herein that the silicone-coated fibers are incorporated into the webs of fibers that form the composite nonwoven textile. Said differently, the silicone coating on the fibers is not applied to the fibers after the composite nonwoven textile is formed using, for example, a silicone spray finish.

[0043] The term “color” or “color property” as used herein when referring to the nonwoven textile generally refers to an observable color of fibers that form the textile. Such aspects contemplate that a color may be any color that may be afforded to fibers using

dyes, pigments, and/or colorants that are known in the art. As such, fibers may be configured to have a color including, but not limited to red, orange, yellow, green, blue, indigo, violet, white, black, and shades thereof. In one example aspect, the color may be imparted to the fiber when the fiber is formed (commonly known as dope dyeing). In dope dyeing, the color is added to the fiber as it is being extruded such that the color is integral to the fiber and is not added to the fiber in a post-formation step (e.g., through a piece dyeing step).

[0044] Aspects related to a color further contemplate determining if one color is different from another color. In these aspects, a color may comprise a numerical color value, which may be determined by using instruments that objectively measure and/or calculate color values of a color of an object by standardizing and/or quantifying factors that may affect a perception of a color. Such instruments include, but are not limited to spectroradiometers, spectrophotometers, and the like. Thus, aspects herein contemplate that a “color” of a textile provided by fibers may comprise a numerical color value that is measured and/or calculated using spectroradiometers and/or spectrophotometers. Moreover, numerical color values may be associated with a color space or color model, which is a specific organization of colors that provides color representations for numerical color values, and thus, each numerical color value corresponds to a singular color represented in the color space or color model.

[0045] In these aspects, a color may be determined to be different from another color if a numerical color value of each color differs. Such a determination may be made by measuring and/or calculating a numerical color value of, for instance, a first textile having a first color with a spectroradiometer or a spectrophotometer, measuring and/or calculating a numerical color value of a second textile having a second color with the same instrument (i.e., if a spectrophotometer was used to measure the numerical color value of the first color, then a spectrophotometer is used to measure the numerical color value of the second color), and comparing the numerical color value of the first color with the numerical color value of the second color.

[0046] In another example, the determination may be made by measuring and/or calculating a numerical color value of a first area of a textile with a spectroradiometer or a spectrophotometer, measuring and/or calculating a numerical color value of a second area of the textile having a second color with the same instrument, and comparing the numerical color value of the first color with the numerical color value of the second color. If the numerical color values are not equal, then the first color or the first color property is different than the second color or the second color property, and vice versa.

[0047] Further, it is also contemplated that a visual distinction between two colors may correlate with a percentage difference between the numerical color values of the first color and the second color, and the visual distinction will be greater as the percentage

difference between the color values increases. Moreover, a visual distinction may be based on a comparison between colors representations of the color values in a color space or model. For instance, when a first color has a numerical color value that corresponds to a represented color that is black or navy and a second color has a numerical color value that corresponds to a represented color that is red or yellow, a visual distinction between the first color and the second color is greater than a visual distinction between a first color with a represented color that is red and a second color with a represented color that is yellow.

[0048] The term “pill” or “pilling” as used herein refers to the formation of small balls of fibers or fibers ends on a facing side of the nonwoven textile. The pill may extend away from a surface plane of the face. Pills are generally formed during normal wash and wear due to forces (e.g., abrasion forces) that cause the fiber ends to migrate through the face of the nonwoven textile and entangle with other fiber ends. A textile’s resistance to pilling may be measured using standardized tests such as Random Tumble and Martindale Pilling tests. The term “pile” as used herein generally refers to a raised surface or nap of a textile consisting of upright loops and/or terminal ends of fibers that extend from a face of the textile in a common direction.

[0049] Various measurements are provided herein with respect to the pre-entangled webs and the resulting composite nonwoven textile. Thickness of the resulting composite nonwoven may be measured using a precision thickness gauge. To measure thickness, for example, the textile may be positioned on a flat anvil and a pressure foot is pressed on to it from the upper surface under a standard fixed load. A dial indicator on the precision thickness gauge gives an indication of the thickness in mm. Basis weight is measured using ISO3801 testing standard and has the units grams per square meter (gsm) . Textile stiffness, which generally corresponds to drape is measured using ASTM D4032 (2008) testing standard and has the units kilogram force (Kgf) . Fabric growth and recovery is measured using ASTM2594 testing standard and is expressed as a percentage.

[0050] The term “stretch” as used herein means a textile characteristic measured as an increase of a specified distance under a prescribed tension and is generally expressed as a percentage of the original benchmark distance (i.e., the resting length or width) . The term “growth” as used herein means an increase in distance of a specified benchmark (i.e., the resting length or width) after extension to a prescribed tension for a time interval followed by the release of tension and is usually expressed as a percentage of the original benchmark distance. “Recovery” as used herein means the ability of a textile to return to its original benchmark distance (i.e., its resting length or width) and is expressed as a percentage of the original benchmark distance. Thermal

resistance, which generally corresponds to insulation features, is measured using ISO11092 testing standard and has the units of RCT ( $M^2 *K/W$ ) .

[0051] Unless otherwise noted, all measurements provided herein are measured at standard ambient temperature and pressure (25 degrees Celsius or 298.15 K and 1 bar) with the nonwoven textile in a resting (un-stretched) state.

[0052] As used herein, the term “about” means generally within  $\pm 10\%$  of an indicated value unless indicated otherwise.

[0053] FIG. 1 is a schematic depiction of an example lifecycle for an example composite nonwoven textile contemplated herein. Reference numeral 100 generally indicates a first web of fibers 110, a second web of fibers 112, a third web of fibers 114, and an elastomeric layer 116 in a stacked configuration prior to entanglement. It is contemplated herein that in some example aspects, one or more of the webs of fibers may be optional. In example aspects, the fibers used to form the first, second, and third web of fibers 110, 112, and 114 may include recycled fibers and, in particular, recycled PET fibers. Additionally, the elastomeric layer 116, in example aspects, may be formed of a material that is recyclable. Arrow 118 schematically represents an entanglement step where the fibers in the first web of fibers 110, the second web of fibers, 112, and the third web of fibers 114 are entangled with each other such that one or more of the fibers extend through the elastomeric layer 116 to form a cohesive composite nonwoven textile 120. Arrow 122 schematically represents a processing step where the composite nonwoven textile 120 is formed into an article of apparel 124. Although the article of apparel 124 is shown as an upper-body garment, it is contemplated herein that the article of apparel 124 may take other forms such as a lower-body garment, an upper of a shoe, a hat, gloves, sleeves, and the like. At the end of the life of the article of apparel 124, it is contemplated that a wearer may return the article of apparel 124 to, for example, the manufacturer/retailer where the article of apparel 124 may be fully recycled as indicated by arrow 126 to form shredded fibers and/or re-extruded fibers that are used to form webs of fibers such as the webs of fibers 110, 112, and 114 and potentially an elastomeric layer such as the elastomeric layer 116 thus creating a self-sustaining loop. This self-sustaining loop reduces the carbon impact typically associated with creating articles of apparel including knit, woven, and nonwoven articles of apparel.

[0054] FIG. 2 depicts the first web of fibers 110 prior to being entangled with other webs. In example aspects, properties associated with the first web of fibers 110 may be selected to achieve desired end properties for the composite nonwoven textile 120. As discussed above, when entangled with other webs, it is contemplated herein that the first web of fibers 110 forms a first face of the composite nonwoven textile 120. When the composite nonwoven textile 120 is formed into an article of apparel, it is

contemplated that the first face forms an outer-facing surface, and in some aspects an outermost-facing surface of the article of apparel. As such, desired properties associated with the first web of fibers 110 include, for example, durability and resistance to abrasion and coverage for modesty. In example aspects, the first web of fibers 110 has a basis weight of from about 20 grams per square meter (gsm) to about 150 gsm, from about 35 gsm to about 65 gsm, from about 40 gsm to about 60 gsm, from about 45 gsm to about 55 gsm, or about 50 gsm. As used herein, the term “about” means generally within  $\pm 10\%$  of an indicated value unless indicated otherwise. Targeting a basis weight in this range for the first web of fibers 110 provides for a resulting nonwoven textile having a basis weight in a desired range after the first web of fibers 110 is combined with other webs and/or elastomeric layers.

[0055] The first web of fibers 110 is formed of fibers, such as fibers 210 (depicted schematically) that may be oriented generally in a common direction, or two or more common directions, due to a carding and cross-lapping process. In example aspects, the fibers 210 may include PET fibers (recycled or virgin) although other virgin and recycled fiber types are contemplated herein (e.g., polyamide, cotton, and the like). In one example aspect, the fibers 210 may include 100% by weight of recycled fibers such as 100% by weight of recycled PET fibers. However, in other aspects, the fibers 210 may include 100% by weight virgin fibers, or other combinations of virgin and recycled fibers, as desired. The staple length of the fibers 210 may range from about 40 mm to about 60 mm, from about 45 mm to about 55 mm, or about 51 mm. Use of this fiber length provides optimal entanglement. For instance, when below 40 mm, the fibers may not have sufficient length to become entangled, and when above 60 mm, the fibers may actually become un-entangled when the needle is withdrawn from the nonwoven textile during entanglement. In example aspects, the fibers 210 may comprise a uniform length such as when the fibers are formed from virgin extruded PET or re-extruded PET and cut to a defined length. In other aspects, the fibers 210 may include a variation of staple length such as when the fibers 210 are derived from a shredded fiber source. Any and all aspects, and any variation thereof, are contemplated as being within aspects herein.

[0056] The fibers 210 may include a denier of greater than or equal to about 1.2 D, or from about 1.2 D to about 3.5 D, from about 1.2 D to about 1.7 D, from about 1.3 D to about 1.6 D, or about 1.5 D. Utilizing a denier within this range makes the fibers 210 less susceptible to breakage which, in turn, enhances the durability and abrasion resistance of the first face of the composite nonwoven textile 120. Moreover, selecting a denier within this range while still achieving the basis weight of the first web of fibers 110 provides good, uniform coverage of the first face which helps enhance the durability features of the first face. Selecting a denier of greater than, for instance

3.5 D while still maintaining the basis weight for the first web of fibers 110 may not provide uniform coverage for the first face.

[0057] In example aspects, the fibers 210 used to form the first web of fibers 110 may include a first color property. The first color property may be imparted to the fibers 210 during, for example, the extrusion process when the fibers 210 are being formed such that the fibers 210 are dope dyed. In one example aspect, the color property may be white although other colors are contemplated herein. Forming the composite nonwoven textile 120 using dope dyed fibers eliminates post-processing dyeing steps which further helps to reduce the carbon footprint of the nonwoven textile 120. For example, it is contemplated herein that the composite nonwoven textile 120 is not piece dyed.

[0058] FIG. 3 depicts the second web of fibers 112 prior to being entangled with other webs. In example aspects, properties associated with the second web of fibers 112 may be selected to achieve desired end properties for the composite nonwoven textile 120. As discussed above, when entangled with other webs, it is contemplated herein that the second web of fibers 112 forms an opposite second face of the composite nonwoven textile 120. When the composite nonwoven textile 120 is formed into an article of apparel, it is contemplated herein that the second face forms an inner-facing surface, and in some aspects an innermost-facing surface of the article of apparel. As such, properties associated with the second web of fibers 112 include, for example, a soft hand or feel. In example aspects, the second web of fibers 112 has a basis weight of from about 20 gsm to about 150 gsm, from about 35 grams per square meter (gsm) to about 65 gsm, from about 40 gsm to about 60 gsm, from about 45 gsm to about 55 gsm, or about 50 gsm. In example aspects, the second web of fibers 112 has generally the same basis weight as the first web of fibers 110. Targeting a basis weight in this range for the second web of fibers 112 provides for a resulting nonwoven textile having a basis weight in a desired range after the second web of fibers 112 is combined with other webs and/or elastomeric layers.

[0059] In example aspects, the second web of fibers 112 may be formed of two types of fibers, such as fibers 310 (depicted schematically) and fibers 312 (depicted schematically) that may be oriented generally in a common direction, or two or more common directions, due to a carding and cross-lapping process. In example aspects, the fibers 310 may include PET fibers (recycled or virgin) although other virgin and recycled fiber types are contemplated herein (e.g., polyamide, cotton, and the like) . In one example aspect, the fibers 310 may include 100%by weight of recycled fibers such as 100%by weight of recycled PET fibers. However, in other aspects, the fibers 310 and/or 312 may include 100%by weight virgin fibers, or other combinations of virgin and recycled fibers, as desired.

[0060] The fibers 312 are shown in dashed line to indicate that they have different features than the fibers 310. For example, the fibers 312 include silicone-coated fibers. The fibers 312 may be coated with silicone prior to incorporating the fibers 312 into the second web of fibers 112. In example aspects, the second web of fibers 112 may include about 10% to about 95% by weight of the fibers 312, about 40% by weight of the fibers 310 and about 60% by weight of the fibers 312, about 45% by weight of the fibers 310 and about 55% by weight of the fibers 312, about 50% by weight of the fibers 310 and about 50% by weight of the fibers 312, about 55% by weight of the fibers 310 and about 45% by weight of the fibers 312, or about 60% by weight of the fibers 310 and about 40% by weight of the fibers 312. In particular aspects, the second web of fibers 112 may include about 50% by weight of the fibers 310 and about 50% by weight of the fibers 312. As stated, it is contemplated herein that the fibers 312 may be intermittently coated with silicone along their length, or the fibers 312 may have a core/sheath configuration. Utilizing the fibers 312 in the ranges above provides a good hand feel to the second face formed by the second web of fibers 112. It also provides a good drape to the composite nonwoven textile 120. Stated differently, the resulting nonwoven textile 120 is not as stiff as traditional nonwovens used in the cleaning space and the personal hygiene space. Further, utilizing the fibers 310 and the fibers 312 in the ranges above may reduce the amount of needle force needed to entangle the web of fibers described herein since the silicone-coated fibers may move more easily during the entanglement process. When incorporating silicone-coated fibers below the ranges described above, the second face may feel dry and uncomfortable during wear. Conversely, when incorporating silicone-coated fibers above the ranges described above, the second face may feel slick, which also may be unpleasant to a wearer. Moreover, using silicone-coated fibers above the ranges described above may make the carding process difficult since the card wires may not be able to frictionally engage with the fibers to achieve a uniform carded web. In addition, using silicone-coated fibers above the ranges described above may also fail to create adequate entanglement between the fibers since frictional forces are reduced due to the silicone thus impacting the structural integrity of the composite nonwoven textile 120.

[0061] Utilizing the silicone-coated fibers 312 eliminates the need for adding a silicone finish to the composite nonwoven textile 120 in a post-processing step. As known in the textile space, it is common practice to add silicone softener finishes to knitted or woven products in a post-processing step. By eliminating this step, the carbon footprint of the composite nonwoven textile 120 is further reduced.

[0062] The staple length of each of the fibers 310 and 312 may range from about 40 mm to about 60 mm, from about 45 mm to about 55 mm, or about 51 mm. Similar to the fibers 210, this length may provide for optimal entanglement. In example aspects,

the fibers 310 and/or 312 may comprise a uniform length such as when the fibers are formed from virgin extruded PET or re-extruded PET and cut to a defined length. In other aspects, the fibers 310 and/or 312 may include a variation of staple length such as when the fibers 310 and/or 312 are derived from a shredded fiber source. Any and all aspects, and any variation thereof, are contemplated as being within aspects herein.

[0063] Each of the fibers 310 and 312 may include a denier of less than or equal to about 1 D. For example, the denier may be about 0.1 D, about 0.2 D, about 0.3 D, about 0.4 D, about 0.5 D, about 0.6 D, about 0.7 D, about 0.8 D, or about 0.9 D. In example aspects, the denier of the fibers 310 and 312 may be from about 0.6 D to about 1 D, from about 0.7 D to about 0.9 D, or about 0.8 D. Utilizing a denier within this range helps to provide a soft feel or hand to the second face formed from the second web of fibers 112. Moreover, selecting a denier within this range while still achieving the basis weight of the second web of fibers 112 provides good coverage of the second face.

[0064] In example aspects, each of the fibers 310 and 312 used to form the second web of fibers 112 may include a color property which may be the same or different. In example aspects, both of the fibers 310 and 312 include the first color property of the fibers 210. Similar to the fibers 210, each of the fibers 310 and 312 may be dope dyed further reducing the need for post-processing dyeing steps for the resulting composite nonwoven textile.

[0065] FIG. 5 depicts the elastomeric layer 116. In example aspects, the elastomeric layer 116 may have a basis weight from about 20 gsm to about 150 gsm, from about 50 gsm to about 70 gsm, from about 55 gsm to about 65 gsm, or about 60 gsm. The basis weight of the elastomeric layer 116 may be selected to achieve a desired basis weight for the resulting composite nonwoven textile. Aspects herein contemplate forming the elastomeric layer 116 from a thermoplastic elastomer such as a thermoplastic polyurethane (TPU), a thermoplastic polyether ester elastomer (TPEE), combinations of TPU and TPEE, and the like. The elastomeric layer may include a spunbond layer, a meltblown layer, a film, a web, and the like. In a particular example aspect, the elastomeric layer 116 may comprise a TPEE spunbond layer, and in another particular aspect, the elastomeric layer 116 may comprise a TPU meltblown layer. In general, the elastomeric layer 116 is selected to provide desirable stretch and recovery properties to the composite nonwoven textile 120 while generally maintaining structural integrity during the entanglement process. The elastomeric layer 116 may also be selected to have a low basis weight to maintain a low basis weight for the resulting composite nonwoven textile 120, to be breathable and permeable which contributes to the comfort features of an apparel item formed from the composite nonwoven textile 120, and to be pliable to reduce the stiffness of the composite nonwoven textile 120. It is con-

templated herein that the elastomeric layer 116 has a color property. In example aspects, the color property may be the first color property associated with the fibers 210, 310, and 312, although different color properties (e.g., a second color property) are contemplated herein.

[0066] FIG. 4 depicts the optional third web of fibers 114 prior to being entangled with other webs. When incorporated into the composite nonwoven textile 120, it is contemplated herein that the third web of fibers 114 is positioned between the first web of fibers 110 and the second web of fibers 112. In example aspects, properties associated with the third web of fibers 114 may be selected to achieve desired end properties for the composite nonwoven textile 120. In example aspects, the third web of fibers 114 may be incorporated into the composite nonwoven textile 120 to achieve a desired basis weight for the composite nonwoven textile 120, to achieve a desired thickness for the composite nonwoven textile 120, to achieve a desired insulation property for the composite nonwoven textile 120, to achieve a desired pile for the composite nonwoven textile 120, and the like. As explained further below, to impart a visual aesthetic to the composite nonwoven textile 120, fibers forming the third web of fibers 114 may have a different color property than fibers used to form the first web of fibers 110 and the second web of fibers 112. Similar to the first web of fibers 110 and the second web of fibers 112, the third web of fibers 114 has a basis weight of from about 20 gsm to about 150 gsm, from about 35 grams gsm to about 65 gsm, from about 40 gsm to about 60 gsm, from about 45 gsm to about 55 gsm, or about 50 gsm. Targeting a basis weight in this range for the third web of fibers 110 provides for a resulting nonwoven textile having a basis weight in a desired range after the third web of fibers 114 is combined with other webs and/or elastomeric layers.

[0067] The third web of fibers 114 is formed of fibers, such as fibers 410 (depicted schematically) that may be oriented generally in a common direction, or two or more common directions, due to a carding and cross-lapping process. In example aspects, the fibers 410 may include PET fibers (recycled or virgin) although other virgin and recycled fiber types are contemplated herein (e.g., polyamide, cotton, and the like) . In one example aspect, the fibers 410 may include 100%by weight of recycled fibers such as 100%by weight of recycled PET fibers. However, in other aspects, the fibers 410 may include 100%by weight virgin fibers, or other combinations of virgin and recycled fibers, as desired. Similar to the fibers 210, 310 and 312, the staple length of the fibers 410 may range from about 40 mm to about 60 mm, from about 45 mm to about 55 mm, or about 51 mm. In example aspects, the fibers 410 may comprise a uniform length such as when the fibers are formed from virgin extruded PET or re-extruded PET and cut to a defined length. In other aspects, the fibers 410 may include a variation of staple length such as when the fibers 410 are derived from a shredded

fiber source. Any and all aspects, and any variation thereof, are contemplated as being within aspects herein.

[0068] The fibers 410 may include a denier of greater than or equal to about 1.2 D, from about 1.2 D to about 3.5 D, from about 1.3 D to about 1.6 D, or about 1.5 D. Utilizing a denier within this range makes the fibers 410 less susceptible to breakage which, in turn, enhances the durability and abrasion resistance of the composite nonwoven textile 120. Since the third web of fibers 114, when used, is positioned between the first web of fibers 110 and the second web of fibers 112, having a soft hand is not as important as, for example, the second web of fibers 112. Selecting a denier within this range while still achieving the basis weight of the third web of fibers 114 enhances the overall coverage and/or opacity of the composite nonwoven textile 120.

[0069] In example aspects, the fibers 410 used to form the third web of fibers 114 may include a second color property different from the first color property. This is depicted in FIG. 4 through the use of diagonal shading lines. It is contemplated herein that the fibers 410 are dope dyed further reducing the carbon footprint of the composite nonwoven textile 120. As will be explained in greater detail below, during the entanglement of the first, second, and third webs of fibers 110, 112 and 114, the fibers 410 may be moved more toward one face than the other face such that the second color property is visually discernible or distinguishable to a greater degree on the one face compared to the other face. It is contemplated herein that the fibers 210 of the first web of fibers 110, the fibers 310 of the second web of fibers 112, and the fibers 410 of the third web of fibers 114 are not coated with silicone.

[0070] FIG. 6 illustrates an example manufacturing process, referenced generally by the numeral 600, for use in making the example composite nonwoven textile 120. The depiction of the manufacturing components in FIG. 6 is illustrative only and is meant to convey general features of the manufacturing process 600. FIG. 6 depicts a conveyance system 610 that transports a stacked configuration 612 of the first web of fibers 110, the second web of fibers 112, the third web of fibers 114, and the elastomeric layer 116 in a machine direction. In one example aspect, the third web of fibers 114 is positioned between the first web of fibers 110 and the elastomeric layer 116 as shown. In another example aspect, the third web of fibers 114 is positioned between the second web of fibers 112 and the elastomeric layer 116. As described, each of the first web of fibers 110, the second web of fibers 112, and the third web of fibers 114 has been carded and lapped to achieve a desired basis weight. As well, each of the webs 110, 112, and 114 has been lightly needled to achieve a cohesive structure. Because the fibers in each of the first, second, and third web of fibers 110, 112, and 114 are in a generally loose web state, they are available for movement during the needle entanglement process. In example aspects, the conveyance system

610 may convey the stacked configuration 612 at a rate from about 2 m/min to about 2.5 m/min, from about 2.1 m/min to about 2.4 m/min, or about 2.3 m/min. This rate provides for a needed level of entanglement via needle beds to produce desired end properties of the composite nonwoven textile (e.g., basis weight, thickness, growth and recovery). Slower rates may cause increased entanglement, which impacts the desired end properties of the composite nonwoven textile 120, and increased rates may cause insufficient entanglement which also impacts the desired end properties of the composite nonwoven textile 120.

[0071] The stacked configuration 612 passes a first needle board indicated as Pass 1 at reference numeral 614. The needles used in the needle boards of the manufacturing process 600 may be selected to optimally interact with the specific denier of the fibers used in the first, second, and third web of fibers 110, 112, and 114. They also may be selected to include a desired number of barbs to achieve a desired degree of entanglement. In example aspects, Pass 1 614 occurs from the first web of fibers 110 in a direction toward the second web of fibers 112 and functionally has the effect of moving and entangling the fibers 210 from the first web of fibers 110 into the third web of fibers 114 and into the second web of fibers 112 and further moving and entangling the fibers 410 from the third web of fibers 114 into the second web of fibers 112. Having Pass 1 614 occur in this direction helps to ensure that the barbs are full of fibers from the first web of fibers 110 and, optionally, the third web of fibers 114 before contacting the elastomeric layer 116 thereby reducing the chances of empty barbs cutting the elastomeric layer 116 and impacting the resulting growth and recovery properties of the composite nonwoven textile 120.

[0072] In example aspects, Pass 1 614 may have a stitch density from about 40 n/cm<sup>2</sup> to about 60 n/cm<sup>2</sup>, from about 45 n/cm<sup>2</sup> to about 55 n/cm<sup>2</sup>, or about 50 n/cm<sup>2</sup>. The penetration depth for Pass 1 614 may be from about 10 mm to about 14 mm, from about 11 mm to about 13 mm, or about 12 mm. A penetration depth of this amount, in example aspects, will generally engage all the barbs of the needles. In one example aspect, all the barbs may comprise five barbs. This penetration depth ensures that the needles pass entirely through the stacked configuration 612 such that fibers in each of the webs 110, 112, and 114 are engaged with the needles. Stated differently, having a penetration depth as described for Pass 1 614 ensures that at least some of the fibers 210 from the first web of fibers 110 are entangled with the fibers 410 of the third web of fibers 114 and entangled with the fibers 310 and 312 of the second web of fibers 112, and at least some of the fibers 410 of the third web of fibers 114 are entangled with the fibers 310 and 312 of the second web of fibers 112. In example aspects, there is an inverse relationship between stitch density and penetration depth. This is to avoid

overworking the fibers and potentially breaking them. Stated differently, when penetration depth is high as with Pass 1 614, the stitch density is lower to avoid potentially breaking the fibers. After Pass 1 614 is complete, the stacked configuration 612 may have a decreased thickness due to the z-direction movement and entanglement of the fibers from the different webs. The stacked configuration 612 may also grow slightly in the cross-machine direction due to cross-machine draft.

[0073] Pass 2 indicated by reference numbers 616 and 618, which occurs subsequent to (i.e., temporally after) Pass 1, occurs from both sides of the stacked configuration 612 in an alternating manner. Stated differently, Pass 2 occurs from both the first web of fibers 110 toward the second web of fibers 112 (reference numeral 616) and from the second web of fibers 112 toward the first web of fibers 110. Thus, Pass 2 616 acts to move the fibers 210 from the first web of fibers 110 into the third web of fibers 114 and into the second web of fibers 112. It also moves the fibers 410 from the third web of fibers 114 through the elastomeric layer 116 and into the second web of fibers 112. Pass 2 618 moves the fibers 310 and 312 through the elastomeric layer 116 and into the third web of fibers 114 and into the first web of fibers 110.

[0074] Both Pass 2 616 and Pass 2 618 have a stitch density of from about 40 n/cm<sup>2</sup> to about 60 n/cm<sup>2</sup>, from about 45 n/cm<sup>2</sup> to about 55 n/cm<sup>2</sup>, or about 50 n/cm<sup>2</sup>. Keeping the stitch density relatively low helps to prevent overworking of the elastomeric layer 116 and thus helps to maintain the desired growth and recovery properties for the resulting composite nonwoven textile 120. The penetration depth for Pass 2 616 and Pass 2 618 is from about 6 mm to about 8 mm. In one example aspect, the penetration depth for Pass 2 616 is about 6 mm, and the penetration depth for Pass 2 618 is about 8 mm. In another example aspect, the penetration depth for Pass 2 616 is about 8 mm, and the penetration depth for Pass 2 618 is about 6 mm. Because the thickness of the stacked configuration 612 is decreased because of Pass 1 614, the penetration depth is reduced for Pass 2 616 and Pass 2 618. It is contemplated herein that the penetration depth for Pass 2 616 and Pass 2 618 is sufficient such that the needles pass completely through the stacked configuration 612. In one example aspect, when the penetration depth is 8 mm, it is contemplated herein that three of the needle barbs are engaged, and when the penetration depth is 6 mm, it is contemplated herein that two of the needle barbs are engaged. After Pass 2 616 and Pass 2 618 are complete, the stacked configuration 612 has even further reduced thickness compared to the stacked configuration 612 after Pass 1 614 and may grow slightly in the cross-machine direction. The end result of Pass 2 216 and Pass 2 618 is further entanglement of the fibers forming the first web of fibers 110, the second web of fibers 112, and the third web of fibers 114.

- [0075] Pass 3 which is indicated by reference numeral 620, occurs subsequent to Pass 2 616 and Pass 2 618 and occurs from the second web of fibers 112 toward the first web of fibers 110. The stitch density for Pass 3 620 is from about 175 n/cm<sup>2</sup> to about 225 n/cm<sup>2</sup>, from about 180 n/cm<sup>2</sup> to about 220 n/cm<sup>2</sup>, from about 190 n/cm<sup>2</sup> to about 210 n/cm<sup>2</sup>, or about 200 n/cm<sup>2</sup>. The higher stitch density of Pass 3 620 achieves a more uniform texturing or working of the stacked configuration 612 compared to passes with lower stitch densities such as Pass 1 614, Pass 2 616, and Pass 3 618. The penetration depth for Pass 3 620 is from about 1 mm to about 5 mm, from about 2 mm to about 4 mm, or about 3 mm. In example aspects, this engages one barb of the needle. The purpose of Pass 3 620 is to tuck some of the fibers into the stacked configuration 612 that are present on the face of the second web of fibers 112 without necessarily creating more entanglement. Said differently, Pass 3 620 helps to reduce the hairiness on the face of the second web of fibers 112.
- [0076] Pass 4 which is indicated by reference numeral 622, occurs subsequent to Pass 3 620 and occurs from the first web of fibers 110 toward the second web of fibers 112. Similar to Pass 3 620, the stitch density for Pass 4 622 is from about 175 n/cm<sup>2</sup> to about 225 n/cm<sup>2</sup>, from about 180 n/cm<sup>2</sup> to about 220 n/cm<sup>2</sup>, from about 190 n/cm<sup>2</sup> to about 210 n/cm<sup>2</sup>, or about 200 n/cm<sup>2</sup>. Also similar to Pass 3 620, the penetration depth for Pass 4 622 is from about 1 mm to about 5 mm, from about 2 mm to about 4 mm, or about 3 mm. In example aspects, this engages one barb of the needle. The purpose of Pass 4 622 is to tuck some of the fibers into the stacked configuration 612 that are present on the face of the first web of fibers 110 without necessarily creating more entanglement. Stated differently, Pass 4 622 helps to reduce the hairiness on the face of the first web of fibers 110. In total, the overall stitch density for the composite nonwoven textile 120 is about 550 with a stitch density of about 300 on the first face formed, at least in part, from the first web of fibers 110 and a stitch density of about 250 on the second face formed, at least in part, from the second web of fibers 112. An overall stitch density of 550 is lower than stitch densities associated with typical nonwovens such as felts in order to achieve more loft and a better hand feel. Moreover, having a lower overall stitch density works less of the fibers such that the fibers from the different webs 110, 112, and 114 are unevenly distributed through the composite nonwoven textile 120, which produces, at least in part, the asymmetric features associated with the different faces. As a result of the different entanglement passes, some of the fibers forming the composite nonwoven textile 120 may be broken such that a staple length of at least some of the fibers forming the composite nonwoven textile 120 may be from about 30 mm to about 45 mm.

- [0077] After Pass 4 622, in example aspects, the entanglement process is complete and the composite nonwoven textile 120 is formed. This is schematically illustrated by the dashed line 624. After Pass 4 622, in example aspects, the composite nonwoven textile 120 may have grown in the machine direction (i.e., the length direction) and in the cross-machine direction (i.e., the width direction) . This concept is known as machine drafting. For example, growth in the cross-machine direction may occur because as the needle passes through the webs of fibers 110, 112, and 114, it creates a void which is filled with fibers which may cause a gradual increase in width dependent upon the stitch density. Growth in the machine direction generally depends on the rate of conveyance and the penetration depth. The stacked configuration 612 continues to move during the entanglement process so an increase in penetration depth may cause a deflection of the fibers based on the dwell time of the needle (i.e., the conveyance rate) . This stretches the composite nonwoven textile 120 in the machine direction.
- [0078] In further example aspects, the composite nonwoven textile 120 exhibits a greater resistance to stretch in the length direction (i.e., the machine direction) compared to the width direction (i.e., the cross-machine direction) . Stated differently, the textile 120 exhibits an anisotropic stretch property. This difference may be due to the machine drafting as discussed above. For instance, the growth in the machine direction may place the fibers forming the first, second, and third webs 110, 112, and 114 under tension resulting in a greater stretch resistance in the machine direction. This anisotropic stretch feature may impact how pattern pieces are cut and positioned on an article of apparel. For example, with respect to an article of apparel such as an upper-body garment, a greater degree of stretch is generally desired in the horizontal direction (e.g., from a first sleeve opening to a second sleeve opening) compared to the vertical direction (e.g., from a neck opening to a waist opening) . Thus, a pattern piece for the upper-body garment would be cut and positioned such that the width of the textile 120 would extend in the horizontal direction and the length of the textile 120 would extend in the vertical direction. Stated differently, the cross-machine direction of the textile 120 would extend in the horizontal direction and the machine direction of the textile 120 would extend vertically.
- [0079] In example aspects, after entanglement, the composite nonwoven textile 120 is ironed. The ironing process, in example aspects, may help to flatten terminal fiber ends extending from facing surfaces of the composite nonwoven textile 120 such that the terminal fiber ends are generally planar with the faces of the composite nonwoven textile 120. This, in turn, may reduce pilling tendencies. Moreover, the ironing process may utilize rollers, and as the composite nonwoven textile 120 wraps around the rollers under tension and is pre-strained, some of the fiber entanglement causes by the manufacturing process 600 may be loosened which may improve the drape and recovery

characteristics of the composite nonwoven textile 120. After ironing, the composite nonwoven textile 120 is rolled to form a rolled good 626, which can later be used for forming articles of apparel. It is also contemplated herein that the composite nonwoven textile 120 may undergo processing steps. For example, the composite nonwoven textile 120 may be conveyed to a patterning station where different pattern shapes may be cut from the nonwoven textile 120. The composite nonwoven textile 120 may also be conveyed to a printing station where various prints are applied to faces of the nonwoven textile 120. The nonwoven textile 120 may also be subject to calendaring, embossing, or different coatings to increase resistance to pilling when this attribute is desired. Any and all aspects, and any variation thereof, are contemplated as being within aspects herein.

[0080] In general, based on the properties selected for each of the first web of fibers 110, the second web of fibers 112, and the third web of fibers 114 (basis weight, fiber denier, staple length, silicone coating, type of fiber, and the like), the properties selected for the elastomeric layer 116 (type of thermoplastic elastomer, construction (film, spunbond, meltblown, web, and the like)), and selection of the entanglement parameters, the composite nonwoven textile 120 includes desired properties. For example, the composite nonwoven textile 120 may have a final thickness of from about 1.8 mm to about 2.7 mm, from about 1.9 mm to about 2.6 mm, or from about 2 mm to about 2.5 mm. The composite nonwoven textile 120 may have a basis weight from about 40 gsm to about 450 gsm, from about 100 gsm to about 350 gsm, from about 150 gsm to about 190 gsm, or about 180 gsm. The final basis weight may be impacted by the number of layers (fiber webs) used in the construction, fiber loss due to stripping, machine draft, and the like. In example aspects, the composite nonwoven textile 120 may have a thermal resistance from about 50 RCT to about 95 RCT, from about 55 RCT to about 90 RCT, from about 60 RCT to about 85 RCT, or from about 65 RCT to about 80 RCT. Thus, as seen, the composite nonwoven textile 120 may exhibit insulation properties associated with typical knit fleeces but have a lower basis weight and/or thickness.

[0081] Due to the elastomeric layer 116, the composite nonwoven textile 120 may have minimal growth properties and good recovery properties. Using the ASTM D2594 testing standard, the composite nonwoven textile 120 may have a growth in the length direction (i.e., the machine direction) of less than or equal to about 5%, less than or equal to about 4%, less than or equal to about 3%, less than or equal to about 2%, less than or equal to about 1%, less than or equal to about 0.1%, or less than or equal to 0%. The composite nonwoven textile 120 may have a growth in the width direction (i.e., the cross machine direction) of less than or equal to about 10%, less than or equal to about 9%, less than or equal to about 8%, less than or equal to about 7%,

less than or equal to about 6%, less than or equal to about 5%, less than or equal to about 4%, less than or equal to about 3%, less than or equal to about 2%, less than or equal to about 1%, less than or equal to about 0.1%, or less than or equal to 0%. Using the ASTM D2594 testing standard, the composite nonwoven textile 120 may have a recovery of within about 10% of its resting length and width, within about 9% of its resting length and width, within about 8% of its resting length and width, within about 7% of its resting length and width, within about 6% of its resting length and width, within about 5% of its resting length and width, within about 4% of its resting length and width, within about 3% of its resting length and width, within about 2% of its resting length and width, or within about 1% of its resting length and width. The stiffness of the composite nonwoven textile 120, which relates to the drapability of the textile 120, is less than or equal to about 0.4 Kgf, less than or equal to about 0.3 Kgf, less than or equal to about 0.2 Kgf, less than or equal to about 0.1 Kgf, or from about 0.1 Kgf to about 0.4 Kgf.

[0082] The features described above (basis weight, thickness, thermal resistance, growth and recovery, and stiffness) may, in some example aspects, make the composite nonwoven textile 120 suitable for a lightweight, thermal article of apparel for use in cool to cold weather conditions (e.g., a pullover, a hoodie, sweat pants, and the like). In other aspects, the features described above may make the composite nonwoven textile 120 suitable for uses in other articles where asymmetric faces are desired such as an upper for an article of footwear.

[0083] FIGS. 7 and 8 illustrate the different faces of the composite nonwoven textile 120. FIG. 7 depicts a first face 710 of the composite nonwoven textile 120 along with the layers of the composite nonwoven textile 120. The first face 710 is formed from a first entangled web of fibers 712. In turn, the first entangled web of fibers 712 includes the fibers 210 from the first web of fibers 110, the fibers 310 and 312 from the second web of fibers 112, and the fibers 410 from the third web of fibers 114. In example aspects, due to the entanglement parameters, the first entangled web of fibers 712 primarily includes the fibers 210 from the first web of fibers 110, while the fibers 310, 312, and 410 are present in smaller amounts. Thus, a unit area, defined herein as a 1 cm x 1 cm area (cm<sup>2</sup>) of the first entangled web of fibers 712 includes a first number of fibers having a first denier from about 1.2 D to about 3.5 D, or about 1.5 denier such as the fibers 210 and the fibers 410 and a second number of fibers having a second denier from about 0.6 D to about 1 D, or about 0.8 D such as the fibers 310 and 312, where the first number of fibers is greater than the second number of fibers. Described differently, the unit area of the first entangled web of fibers 712 has a ratio of the first denier to the second denier in a range of from about 1.5: 1 to about 2: 1 or about 1.9: 1. Another way to describe this is that the first entangled web of fibers 712 has a first

average denier per  $\text{cm}^2$ . The first average denier may be determined by taking a set number of fibers (e.g., 100 fibers) per  $\text{cm}^2$ , determining the denier of the fibers, and determining the average denier. In example aspects, the first average denier per  $\text{cm}^2$  may be from about 1.1 D to about 1.4 D.

[0084] FIG. 7 further depicts a second entangled web of fibers 718 that forms a second face 810 of the composite nonwoven textile 120 as shown in FIG. 8. The second entangled web of fibers 718 includes the fibers 310 and 312 from the second web of fibers 112, the fibers 410 from the third web of fibers 114, and the fibers 210 from the first web of fibers 110. In example aspects, due to the entanglement parameters, the second entangled web of fibers 718 primarily includes the fibers 310 and 312 from the second web of fibers 112, while the fibers 210 and 410 are present in smaller amounts. Thus, a unit area of the second entangled web of fibers 718 includes a third number of fibers having a third denier from about 0.6 to about 1 D, or about 0.8 D such as the fibers 310 and 312, and a fourth number of fibers having a fourth denier from about 1.2 D to about 3.5 D, or about 1.5 denier such as the fibers 210 and the fibers 410, where the third number of fibers is greater than the fourth number of fibers. Described differently, a unit area of the second entangled web of fibers 718 has a ratio of the third denier to the fourth denier in a range of from about 0.3: 1 to about 0.7: 1, or about 0.5: 1. Another way to describe this is that the second entangled web of fibers 718 has a second average denier per  $\text{cm}^2$ . The second average denier per  $\text{cm}^2$  may be less than the first average denier per  $\text{cm}^2$ . In example aspects, the second average denier per  $\text{cm}^2$  may be from about 0.9 D to about 1 D.

[0085] As shown in both FIGs. 7 and 8, the composite nonwoven textile 120 further includes a third entangled web of fibers 714. The third entangled web of fibers 714 includes the fibers 410 from the third web of fibers 114, the fibers 310 and 312 from the second web of fibers 112, and the fibers 210 from the first web of fibers 110. In example aspects, due to the entanglement parameters, the third entangled web of fibers 714 primarily includes the fibers 410 from the third web of fibers 114, while the fibers 310, 312, and 210 are present in smaller amounts. More particularly, because the needles pass through the first web of fibers 110 and/or the second web of fibers 112 before contacting the third web of fibers 114, the needle barbs are generally full of fibers and thus there may not be a lot of movement of the fibers 410 during the entanglement process. Thus, a unit area of the third entangled web of fibers 714 includes a fifth number of fibers having a fifth denier from about 1.2 D to about 3.5 D, or about 1.5 denier such as the fibers 410 and the fibers 210 and a sixth number of fibers having a sixth denier from about 0.6 D to about 1 D, or about 0.8 D such as the fibers 310 and 312, where the fifth number of fibers is greater than the sixth number of fibers.

Described differently, a unit area of the third entangled web of fibers 714 has a ratio of the fifth denier to the sixth denier in a range of from about 1.5: 1 to about 2: 1 or about 1.9: 1. Another way to describe this is that the third entangled web of fibers 714 has a third average denier per  $\text{cm}^2$ . In example aspects, the third average denier per  $\text{cm}^2$  may be greater than the second average denier per  $\text{cm}^2$ . In example aspects, the third average denier per  $\text{cm}^2$  may be from about 1.1 D to about 1.4 D.

[0086] The composite nonwoven textile 120 shown in FIGs. 7 and 8 further includes the elastomeric layer 116. In the configuration shown in FIGs. 7 and 8 where the elastomeric layer 116 is positioned between second entangled web of fibers 718 and the third entangled web of fibers 714, at least some of the fibers from the first entangled web of fibers 712 and the third entangled web of fibers 714 extend through the elastomeric layer 116 and are entangled with the fibers of the second entangled web of fibers 718, and at least some of the fibers of the second entangled web of fibers 718 extend through the elastomeric layer 116 and are entangled with the fibers of the first entangled web of fibers 712 and the third entangled web of fibers 714. In example aspects, portions of the elastomeric layer 116 do not appreciably move in the z-direction during the entanglement process. Stated differently, the elastomeric layer 116 extends generally uniformly along an x, y plane and generally remains as a cohesive, unitary structure except for holes through which fibers of the different entangled webs 712, 714, and 718 extend.

[0087] Although the different entangled webs 712, 714 and 718 are shown as distinct layers in FIGs. 7 and 8, it is contemplated herein, that the entangled webs 712, 714 and 718 are entangled to form a cohesive structure. That said, in example aspects, each of the webs 712, 714, and 718 retains features of a distinct layer such that the entangled webs 712, 714 and 718 are distinctly visible in a cross-section of the composite nonwoven textile 120 thus providing a unique aesthetic to cut edges of the composite nonwoven textile 120.

[0088] As further shown in FIG. 7 and 8, the second face 810 formed from the second entangled web of fibers 718 includes the silicone-coated fibers 312 (shown in dashed line) in a greater number than the silicone-coated fibers 312 present on the first face 710 formed from the first entangled web of fibers 712. Stated differently, a unit area of the second entangled web of fibers 718 includes a greater number of the silicone-coated fibers 312 than a unit area of the first entangled web of fibers 712. Further, a unit area of the third entangled web of fibers 714 includes a smaller number of silicone-coated fibers 312 as compared to a unit area of the second entangled web of fibers 718. In example aspects, it is contemplated herein that the composite nonwoven textile 120 may comprise from about 10% to about 25% by weight of the silicone-

coated fibers 312. As stated previously, having the second face 810 of the composite nonwoven textile 120 include silicone-coated fibers provides a soft hand to the second face 810 and reduces the stiffness (i.e., increases the drapability) of the composite nonwoven textile 120.

[0089] FIG. 9 depicts a cross-section of the composite nonwoven textile 120 of FIG. 7 and illustrates the entanglement of fibers from the different entangled webs of fibers. As shown, the composite nonwoven textile 120 includes the first entangled web of fibers 712 that forms the first face 710, the second entangled web of fibers 718 that forms the second face 810, the third entangled web of fibers 714, and the elastomeric layer 116. In the cross-section shown in FIG. 9, the third entangled web of fibers 714 is positioned between the first entangled web of fibers 712 and the elastomeric layer 116 although other aspects contemplate that the third entangled web of fibers 714 is positioned between the second entangled web of fibers 718 and the elastomeric layer 116. As stated previously, it is contemplated herein that one or more of the entangled webs of fibers 712, 714, and/or 718 may be optional.

[0090] Moving from left to right, the fiber 210 from the first entangled web of fibers 712 is shown entangled with the fibers 310 and/or 312 from the second entangled web of fibers 718, and the fiber 210 from the first entangled web of fibers 712 is shown entangled with the fiber 410 from the third entangled web of fibers 714. The fiber 410 from the third entangled web of fibers 714 is shown entangled with the fibers 310 and/or 312 from the second entangled web of fibers 718, and the fiber 410 from the third entangled web of fibers 714 is shown entangled with the fiber 210 from the first entangled web of fibers 712. The fibers 310 and/or 312 from the second entangled web of fibers 718 is shown entangled with the fiber 210 from the first entangled web of fibers 712, and the fibers 310 and/or 312 is shown entangled with the fiber 410 from the third entangled web of fibers 714. As shown, one or more of the fibers 210, 310, 312, and 410 extend through the elastomeric layer 116. Some of the fibers in FIG. 9 are shown as darkened but this is for illustrative purposes only.

[0091] FIG. 10 depicts an alternative cross-section of the composite nonwoven textile 120. As shown in FIG. 10, instead of the elastomeric layer 116 being positioned between the third entangled web of fibers 714 and the second entangled web of fibers 718, the elastomeric layer 116 is positioned between the first entangled web of fibers 712 and the third entangled web of fibers 714. The fibers of the different layers are shown entangled together and extending through the elastomeric layer 116 as described for FIG. 9.

[0092] FIG. 11 depicts the cross-section of FIG. 9 with only the silicone-coated fibers 312 shown. As shown in FIG. 11, the silicone-coated fibers 312 are present in a greater amount in the second entangled web of fibers 718 but extend through the elastomeric

layer 116 into the first entangled web of fibers 712 and the third entangled web of fibers 714.

[0093] In some examples, it can be desirable to have a pleated construction for a nonwoven textile, such as the nonwoven textile 120. For example, referring to FIGS. 12 and 13. An example of a pleated construction 1200 is illustrated, which includes a nonwoven textile 1210 (FIG. 12), an elastically resilient structured textile 1212 (FIG. 13), and a plurality of pleats 1214.

[0094] In examples, the nonwoven textile 1210 can include the nonwoven textile 120 or any one or more of the other layers described in this disclosure. For example, the nonwoven textile 1210 may include any one or more of the layers 110, 112, 114, 712, 714, or 718. The nonwoven textile 1210 can include any one or more of a web of entangled staple fibers, spun-bonded textile, spunlace textile, melt-blown textile, and the like, and any and all combinations thereof. In examples in which the nonwoven textile 1210 includes a cross direction, this axis, direction, or orientation can be referred to as “x” or “x-axis” or “x-direction,” and includes a machine direction, this axis, direction, or orientation can be referred to as “y” or “y-axis” or “y-direction.” In some examples a general plane or planar orientation of the nonwoven textile can be referred to as the x-y plane.

[0095] As used herein, the term “structured textile” means a textile that has one of a knit or woven construction, and the term “elastically resilient” means that the textile returns to substantially its original length after being subject to tensioning forces. In some examples, the an elastically resilient structure textile can include a power mesh material layer.

[0096] FIG. 12 illustrates a first side or face 1201 of the pleated construction 1200 that is formed, at least in part, from the nonwoven textile 1210, and FIG. 13 illustrates a second side or face 1202 of the pleated construction 1200 that is formed, at least in part, from the elastically resilient structured textile 1212. Moreover, as discussed hereinafter, the pleated construction 1200 is configured in a manner such that peaks of the plurality of pleats 1214 are formed at the first side 1201 and valleys of the plurality of pleats 1214 are formed at the second side 1202. In examples, the pleats 1214 can include the nonwoven textile extending in a z-direction away from the elastically resilient structured textile 1212.

[0097] In examples, a construction of the pleats 1214 can include the elastically resilient structured textile 1212 coupled to the nonwoven textile 1210 via a series of stitches 1216 that are arranged in rows.

[0098] FIG. 14 illustrates an example manufacturing process. In at least some examples, a nonwoven textile 1210 is stacked relative to an elastically resilient structure textile 1212. For example, the nonwoven textile 1210 and the elastically resilient structure

textile 1212 can be loaded into a stitching machine (e.g., FIG. 15) , such as a quilting machine or other stitching machine that can apply a series of stiches in a series of rows.

- [0099] In some examples, the nonwoven textile 1210 and the elastically resilient structure textile 1212 can include rolled goods that are loaded into a stitching machine.
- [0100] With continued reference to FIG. 14, tension can be applied the elastically resilient structure textile 1212 such that the elastically resilient structure textile 1212 is elongated or stretched relative to the nonwoven layer 1210. For example, tension can be applied to the rolled good form of the elastically resilient structure textile 1212 that is loaded into the stitching machine (e.g., FIG. 15) .
- [0101] In some example, the elastically resilient structure textile 1212 is elongated in a direction that is substantially aligned with the machine direction (MD) of the nonwoven textile 1210.
- [0102] In examples, while the elastically resilient structure textile 1212 is elongated or stretched relative to the nonwoven layer 1210, a series of stitches 1216 is applied to the nonwoven layer 1210 and the elastically resilient structured textile 1212. That is, stitches are applied such that the stitched thread passes through both the nonwoven layer 1210 and the elastically resilient structure textile 1212 and effectively couples the layers together at the stitch locations.
- [0103] In some examples, the series of stitches are applied in a serpentine-like pattern. As such, a resulting textile with a pleat construction (e.g., 1200) can also include a series of stitches organized in a serpentine-like pattern. In examples, serpentine-like pattern can include two or more rows of stitches, in which adjacent rows of stitches are connect at only one end. In some examples, the series of stitches are a continuous series.
- [0104] In some examples, the rows of stitches in the serpentine-like pattern can be relatively straight. In some examples, the rows of stitches can be substantially parallel relative to one another.
- [0105] In some examples, the rows of stitches can be wavy. In some examples, the rows of stitches can be non-parallel relative to one another.
- [0106] In some examples, a row of stiches (e.g., a single row of stitches) can extend in a direction that is substantially perpendicular to the direction in which the elastically resilient structured textile 1212 is stretched or elongated.
- [0107] In some examples, a row of stiches (e.g., a single row of stitches) and/or each row of multiple rows of stitches can extend in a direction that is substantially perpendicular to the machine direction associated with the nonwoven textile 1210. As such, a resulting textile, pattern piece, or trim piece (e.g., cuff or hem) with a pleat construction (e.g.,

1200) can also include one or more rows of stitches that extend in a direction substantially perpendicular to the machine direction.

[0108] In some examples, two or more sets of rows of stitches (e.g. 1402 and 1404 and 1406) can be applied to the nonwoven textile 1210 and the elastically resilient structured textile 1212. In some examples, the two or more sets of rows of stitches can be simultaneously applied. For example, the two or more sets of rows of stitches can be simultaneously applied by as quilting machine (or other stitching machine) , such as the machine shown in FIG. 15 and as the resulting stitch rows show in FIG. 16. In some examples, a margin is provided between the sections (e.g., 1402, 1404, and 1406) , such that when a section is cut away (e.g., for incorporation into a wearable article) , the stitch rows are not cut) . In other words, the margin is configured to be cut without severing the stitches. In some examples, the margin can provide a portion of the pleat construction to be affixed to a wearable article (e.g., the margin, after being cut, can also serve as a connecting edge or portion for seaming onto a wearable article) .

[0109] In some examples, the tension that was applied to the elastically resilient structured material 1212 is released, such that the stitch rows are drawn towards one another, and the nonwoven textile 1210 is biased outward and away from the elastically resilient structured material 1212. As such, the nonwoven textile 1210 that is between the stitch rows forms a rib or pleat structure (e.g. 1214) . Stated differently, the nonwoven textile can extend in the z-direction and away from the elastically resilient structured material.

[0110] In some examples, the nonwoven textile 1210 can include a fiber (e.g., as part of a fiber web that extends through multiple pleats and/or intersects with multiple stitch rows. In some examples, a cross-pleat fiber can extend at least partially in one or more of the x-y directions associate with the cross direction and machine direction of the nonwoven textile, as well as the z-direction associated with the height of the pleat. Among other things, these cross-pleat fibers can improve the strength of the pleated construction, such as by forming a continuous structure.

[0111] In some examples, the pleated construction 1200 can be formed into at least a portion of a wearable article, such as a cuff, hem, collar, or other portion of an upper-body garment, lower-body garment, or footwear article. For example, referring to FIG. 17, a segment of the pleated construction 1700 can be cut along the margins between the sections (e.g., 1402, 1404, and 1406) . In some examples, the margin can include an offset between the nonwoven textile and the elastically resilient structured material that is less than the height of the pleat in the z-direction, which can be conducive to cutting, seaming, and other processing.

[0112] Another example of a pleated construction 1800 is depicted in FIG. 18.

[0113] Referring to FIG. 19, an example of a pleated construction 1900 forming a cuff on an arm sleeve is shown. For example, a section that has been cut away from the larger

rolled good can be folded in half and seamed onto another part of the wearable article (e.g., onto the arm sleeve, leg sleeve, waist band, ankle collar, etc. ) .

- [0114] In examples, the pleated construction can include various properties. For example, in some instances, the stitches can include a stitch density that is large enough to maintain, for a given pleat, a z-height. That is, in some instances, if the stitch density is too low, the pleat may at least partially collapse, such that it flattens out (or at least fails to maintain a target z-height).
- [0115] In some examples, the stitch density is in a range of about 3 stitches per inch (SPI) to about 20 SPI. In some examples, the stitch density is in a range of about 5 SPI to about 15 SPI. In some examples, the stitch density is in a range of about SPI to about 12 SPI.
- [0116] In some examples, the stitch density can be configured based on a basis weight of the nonwoven textile.
- [0117] In some examples, the stitch density can be based on a bending property or stiffness of the nonwoven textile.
- [0118] In some examples, the
- [0119] In some examples, at least a portion of the nonwoven textile can include fibers or filaments that extend in one or more orientations relative to the orientation of a stitch row. For example, if the orientation of the stitch row is associated with a y-axis, then the nonwoven textile can include fibers or filaments that are substantially aligned with the y-axis, that are skewed relative to the y-axis, or any combination thereof. In some examples, the variability of the fiber or filament orientation can provide relatively even shaped pleats that maintain their shape.
- [0120] As indicated, in some examples, each row of stitches can extend in the cross direction (e.g., x-direction or perpendicular to the machine direction) , and as such, a pleat that protrudes in the z-direction between two rows of stitches can include a longitudinal orientation that is also aligned in the cross direction. One or more pleats having a longitudinal orientation extending in the cross direction can include a first set of properties (e.g., bending stiffness transverse to the pleat (s) , collapse resistance, etc. ) . In some examples, each row of stitches can extend in the machine direction (e.g., x-direction or perpendicular to the machine direction) , and as such, a pleat that protrudes in the z-direction between two rows of stitches can include a longitudinal orientation that is also aligned in the machine direction. One or more pleats having a longitudinal orientation extending in the machine direction can include a second set of properties (e.g., bending stiffness transverse to the pleat (s) , collapse resistance, etc. ) , which is different from the first set of properties. In some examples, an orientation of the stich rows can be configured to achieve desired pleat properties.
- [0121] In some examples, a chemical binder can be applied to the nonwoven textile (e.g., prior to attaching the nonwoven textile to the elastically resilient structured material)

to reduce the formation of pills on at least the outer face of the nonwoven textile. As used herein, the term “chemical bonding” refers to the use of chemical binders (e.g., adhesive materials) that are used to hold fibers together. The chemical binder joins fibers together at fiber intersections and fiber bonding results. In one example aspect, the chemical binder may form an adhesive film the bonds the fibers together at, for example, fiber intersections. Because the fibers are adhered together, the terminal ends of the fibers are less prone to migration and pilling and the overall pilling resistance of at least the outer face of the nonwoven textile is increased.

[0122] In examples, chemical binders can include those that comprise polymers and may include vinyl polymers and copolymers, acrylic ester polymers and copolymers, rubber and synthetic rubber, and natural binders such as starch. The chemical binder may be applied in an aqueous dispersion, an oil-based dispersion, a foam dispersion, and the like. In example aspects, a base coating or primer may be applied to the composite nonwoven textile before application of the chemical binder. In one example aspect, the chemical binder may include an oil-based polyurethane binder. The term “chemical bonding site,” as used herein refers to the location of the chemical bond and it further refers to the chemical binder itself as applied to the composite nonwoven textile at the chemical bonding site.

[0123] In example aspects, the chemical binder can compositionally comprise an oil-based dispersion of a polyurethane binder, a polyurethane binder in a dispersion that contains silica, and combinations thereof. In example aspects, the use of silica reduces the friction between fibers to which the chemical binder is applied, which will make the fibers less likely to pill when exposed to abrasion or external friction (i.e., they slide more easily relative to each other). As stated, the chemical binder acts as an adhesive helping to secure fibers together in areas where it is applied. Because the fibers are adhered together, the terminal ends of the fibers are less prone to pilling and the overall pilling resistance of at least the outer first face of the nonwoven textile is increased. For example, the pilling resistance may be about 2, 2.5, or more on the Martindale Pilling test.

[0124] As previously described, in example aspects, when the pleated construction is incorporated into a garment (e.g., as a cuff, waistband, hem, neck collar, ankle collar etc.), the pleated construction can be folded and affixed to another portion of the garment, such that the nonwoven textile with the pleats forms the outer-facing surface that faces away from the wearer and the inner-facing surface that faces towards the wearer. Thus, the application of the chemical binder to the nonwoven textile helps to increase the pilling resistance of the outer-facing portion of the cuff, waistband, hem, neck collar, ankle collar, etc., which may be more prone to abrasion from environmental elements, as well as to the portion of the cuff, waistband, hem, neck collar,

ankle collar, etc. that faces towards the wearer (e.g., the inner-facing) , which can be susceptible to higher wear, abrasion, and/or contact with the wearer (and thus susceptible to higher pilling) .

[0125] In some examples, a thermal bonding process may be applied to one or more faces of the nonwoven textile, (e.g., prior to attaching the nonwoven textile to the elastically resilient structured material) to reduce the formation of pills on at least the outer face of the nonwoven textile. As used herein, the term “thermal bonding” refers to a process that may include locally heating fibers to melt, partially melt, and/or soften the fibers. This permits polymer chain relaxation and diffusion or polymer flow across fiber-fiber interfaces between two crossing fibers. Subsequent cooling of the fibers causes them to re-solidify and to trap the polymer chain segments that diffused across the fiber-fiber interfaces. The thermal bonds trap the terminal ends of the fibers and makes the fibers ends less prone to interacting with other fiber ends to form pills. As used herein, the term “thermal bonding site, ” refers to the location of the thermal bond on the composite nonwoven textile, and the term “thermal bond structure” refers to the actual structure formed by the re-solidified fibers and/or materials and typically includes fibers and materials from the different webs of fibers used to form the nonwoven textile. The term “film form” as used herein also refers to a structure formed by the re-solidified fibers and/or materials.

[0126] As previously described, in example aspects, when the pleated construction is incorporated into a garment (e.g., as a cuff, waistband, hem, neck collar, ankle collar etc. ) , the pleated construction can be folded and affixed to another portion of the garment, such that the nonwoven textile with the pleats forms the outer-facing surface that faces away from the wearer and the inner-facing surface that faces towards the wearer. Thus, the application of the thermal bonding sites to the nonwoven textile helps to increase the pilling resistance of the outer-facing portion of the cuff, waistband, hem, neck collar, ankle collar, etc., which may be more prone to abrasion from environmental elements, as well as to the portion of the cuff, waistband, hem, neck collar, ankle collar, etc. that faces towards the wearer (e.g., the inner-facing) , which can be susceptible to higher wear, abrasion, and/or contact with the wearer (and thus susceptible to higher pilling) .

[0127] This detailed description is provided in order to meet statutory requirements. However, this description is not intended to limit the scope of the invention described herein. Rather, the claimed subject matter may be embodied in different ways, to include different steps, different combinations of steps, different elements, and/or different combinations of elements, similar or equivalent to those described in this disclosure, and in conjunction with other present or future technologies. The examples herein are intended in all respects to be illustrative rather than restrictive. In this sense,

alternative examples or implementations can become apparent to those of ordinary skill in the art to which the present subject matter pertains without departing from the scope hereof.

## Claims

- [Claim 1] A pleated construction comprising:  
a nonwoven textile;  
an elastically resilient structured textile; and  
at least two rows of stitches connecting the nonwoven textile to the elastically resilient structured textile, wherein:  
the nonwoven textile and the elastically resilient structured textile extend in an x-y planar orientation; and  
between the at least two rows of stitches, the nonwoven textile extends in a z-direction away from the elastically resilient structured textile.
- [Claim 2] The pleated construction of claim 1, wherein an x-direction of the x-y planar orientation is generally aligned with a cross direction associated with the nonwoven textile, and wherein a y-direction of the x-y planar orientation is generally aligned with a machine direction associated with the nonwoven textile.
- [Claim 3] The pleated construction of claim 1 or claim 2, wherein the nonwoven textile comprises a fiber having a first portion that extends at least partially in the x-direction, a second portion that extends at least partially in the y-direction, and a third portion that extends at least partially in the z-direction.
- [Claim 4] The pleated construction of any of claims 1 through 3, wherein the at least two rows generally extend along the x-direction.
- [Claim 5] The pleated construction of any of claims 1 through 4, wherein the nonwoven textile comprises an entangled fiber web.
- [Claim 6] The pleated construction of claim 5, wherein:  
the entangled fiber web comprises a first entangled fiber web;  
the nonwoven textile comprises a second entangled fiber web and an elastomeric layer positioned between the first entangled fiber web and the second entangled fiber web; and  
at least some fibers of the first entangled fiber web extend through the elastomeric layer and are entangled with the second entangled fiber web.
- [Claim 7] The pleated construction of any of claims 1 through 6, wherein the at least two rows of stitches comprises a stitch density in a range of 3 stitches per inch (SPI) to 20 SPI.
- [Claim 8] The pleated construction of any of claims 1 through 7, wherein:

- the nonwoven textile comprises a machine direction and a cross direction; and
- a stretch property of the nonwoven textile is different in the machine direction than in the cross direction.
- [Claim 9] The pleated construction of claim 8, wherein the stretch property comprises a modulus of elasticity.
- [Claim 10] The pleated construction of any of claims 1 through 9, wherein the nonwoven textile comprises a plurality of chemical bonding sites on a face oriented away from the elastically resilient structured textile.
- [Claim 11] The pleated construction of claim 10, wherein the pleated construction forms a portion of a wearable article.
- [Claim 12] The pleated construction of claim 11, wherein:  
the pleated construction forms at least one of a cuff, a waistband, a hem, an ankle collar, or a neck collar; and  
the chemical binder is on a face configured to be oriented away from a wearer and on a face configured to be oriented towards the wearer.
- [Claim 13] The pleated construction of any of claims 1 through 14, wherein the nonwoven textile comprises a plurality of thermal bonding sites on a face oriented away from the elastically resilient structured textile.
- [Claim 14] The pleated construction of any of claims 1 to 13, wherein the nonwoven textile comprises a basis weight in a range of 100 gsm to 350 gsm.
- [Claim 15] The pleated construction of claim 14, wherein the basis weight is about 180 gsm.
- [Claim 16] The pleated construction of any of claims 1 to 15, wherein the at least two rows of stitches are connected to each other only at one end by one or more stitches.
- [Claim 17] A pleated construction comprising:  
a nonwoven textile;  
an elastically resilient structured textile;  
a first set of stitches attaching the nonwoven textile to the elastically resilient structured textile;  
a second set of stitches attaching the nonwoven textile to the elastically resilient structured textile, wherein the first set of stitches are separated from the second set stitches by a margin.
- [Claim 18] The pleated construction of claim 17, wherein the margin comprises a seam allowance configured to be cut without severing stitches of the first set of stitches or the second set of stitches.

- [Claim 19] The pleated construction of claim 17 or claim 18, wherein:  
the first set of stitches comprises at least two rows of stitches; and  
the second set of stitches comprises at least two rows of stitches.
- [Claim 20] The pleated construction of claim 19, wherein the at least two rows of stitches of at least the first set of stitches are connected at only one end by one or more stitches.
- [Claim 21] The pleated construction of claim 19, wherein the at least two rows of stitches of at least the first set of stitches comprise a continuous series of stitches.
- [Claim 22] The pleated construction of any of claims 19 to 21, wherein  
the at least two rows of stitches of the first and second sets of stitches extend in a cross direction associated with the nonwoven textile; and  
the first set of stitches are separated from the second set stitches in the cross direction.
- [Claim 23] The pleated construction of any of claims 19 to 22, wherein:  
the nonwoven textile and the elastically resilient structured textile extend in an x-y planar orientation; and  
between the at least two rows of stitches of the first set of stitches, the nonwoven textile extends in a z-direction away from the elastically resilient structured textile.
- [Claim 24] The pleated construction of claim 23, wherein between the at least two rows of stitches of the first set of stitches, the nonwoven textile extends in the z-direction by an amount that is greater than an offset between the nonwoven textile and the elastically resilient structured textile associated with the margin.
- [Claim 25] A method of making a pleat construction, the method comprising:  
stacking a nonwoven textile and an elastically resilient structured textile;  
stretching the elastically resilient structured textile by applying a force;  
applying at least two rows of stitches to the nonwoven textile and an elastically resilient structured textile; and  
releasing the force.
- [Claim 26] The method of claim 25, wherein the at least two rows of stitches are applied in a direction aligned with a cross direction associated with the nonwoven textile.
- [Claim 27] The method of claim 25 or claim 26 further comprising, applying two or more sets of two or more rows of stitches side-by-side.

[Claim 28]

The method of claim 27 further comprising, omitting stitches from a margin between the two or more sets.

[ Fig. 1 ]

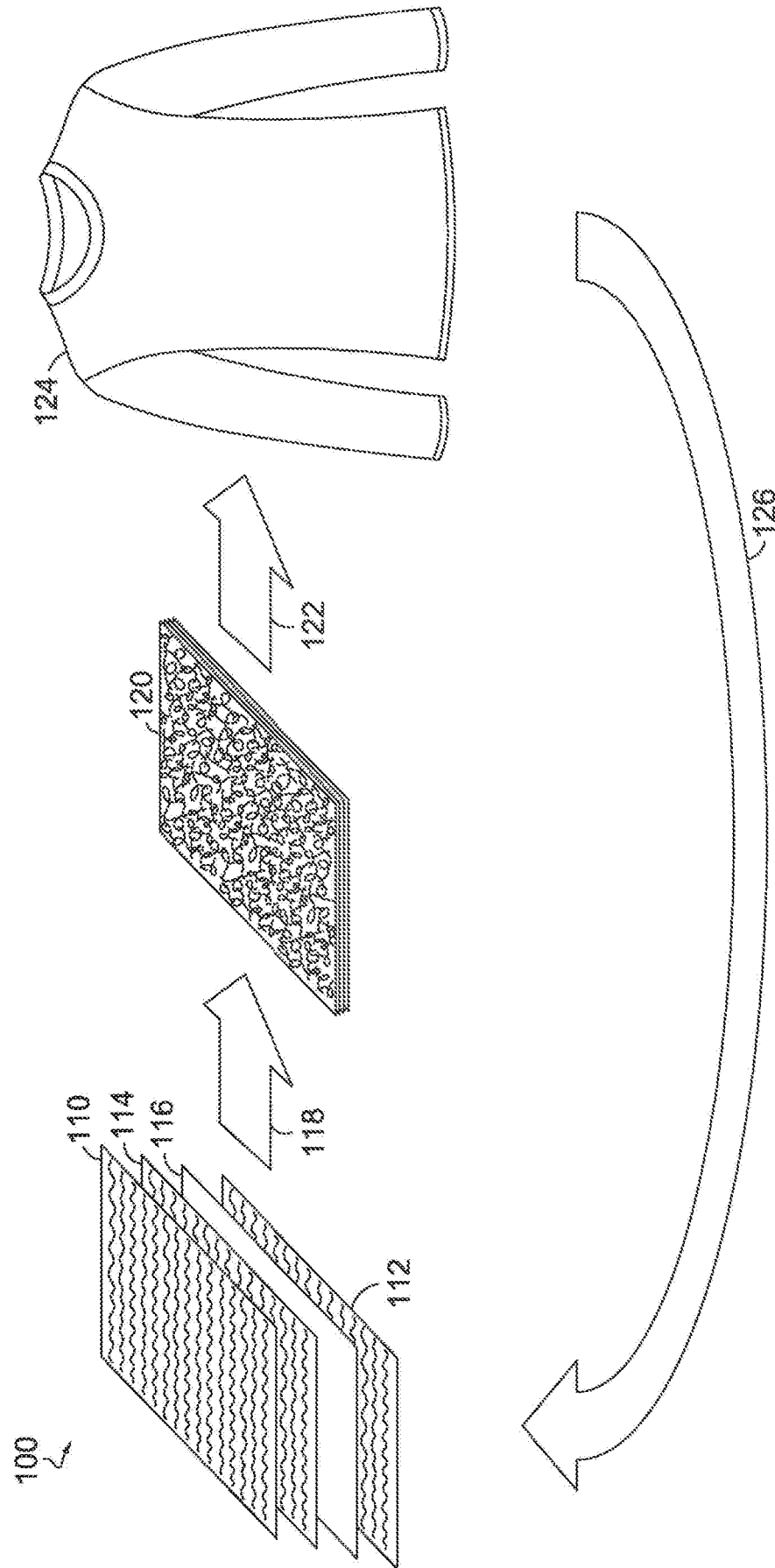

[ Fig. 2 ]

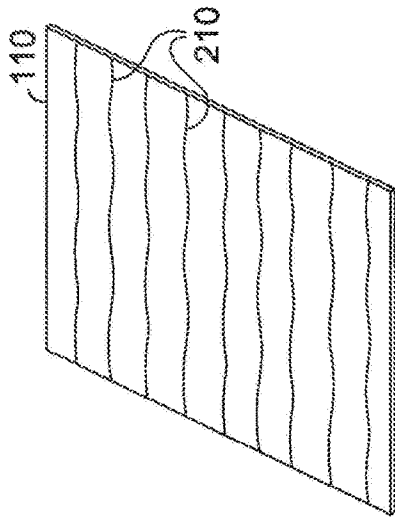

[ Fig. 3 ]

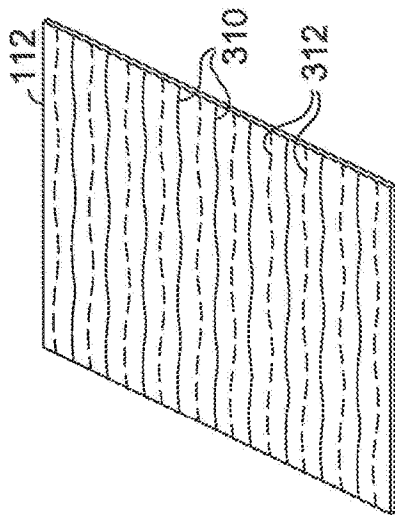

[ Fig. 4 ]

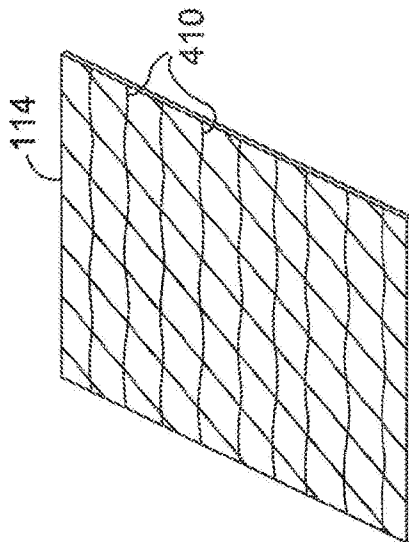

[ Fig. 5]

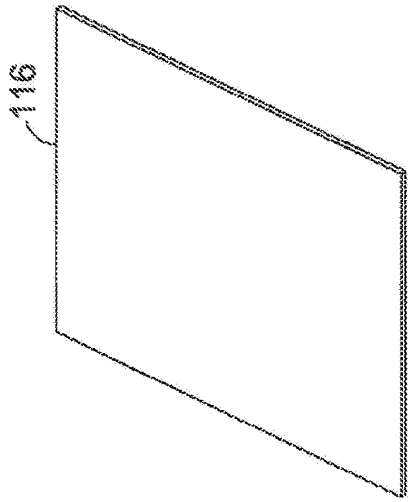

[ Fig. 6 ]

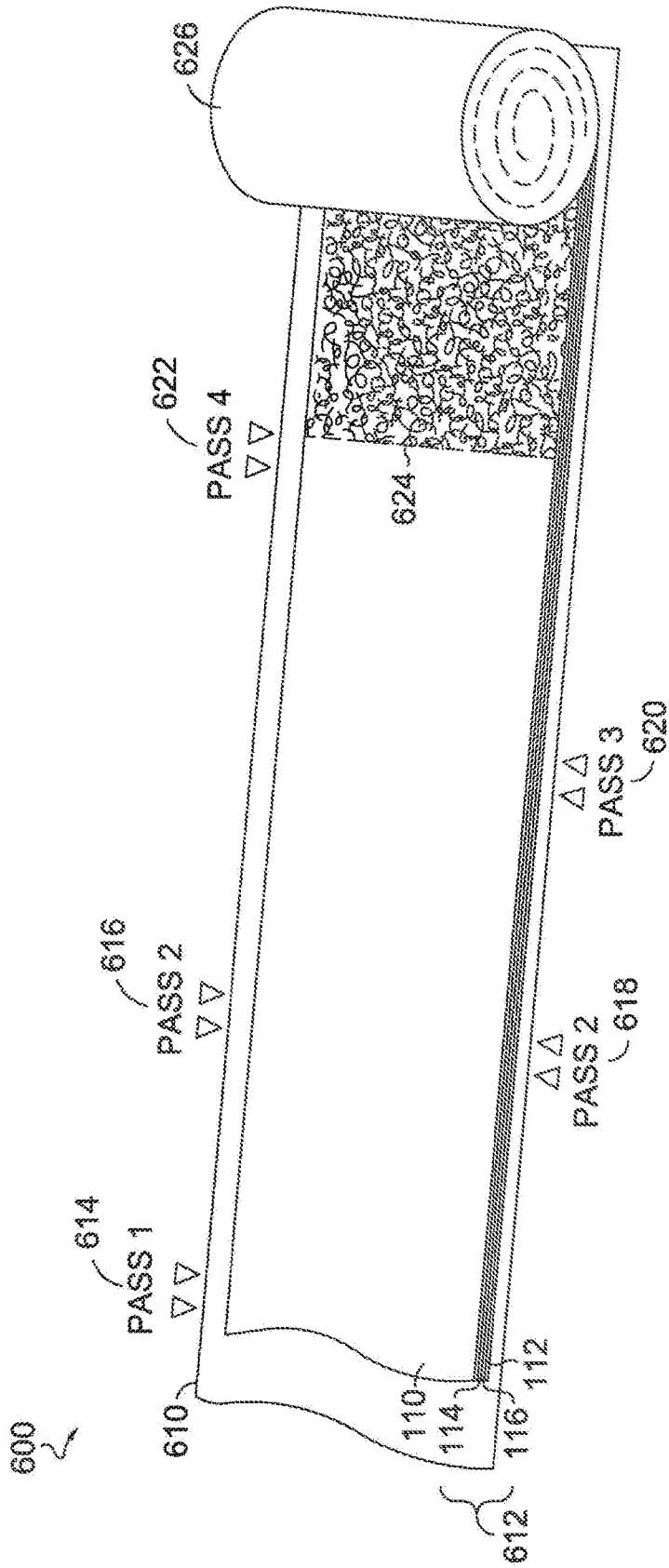

[ Fig. 7 ]

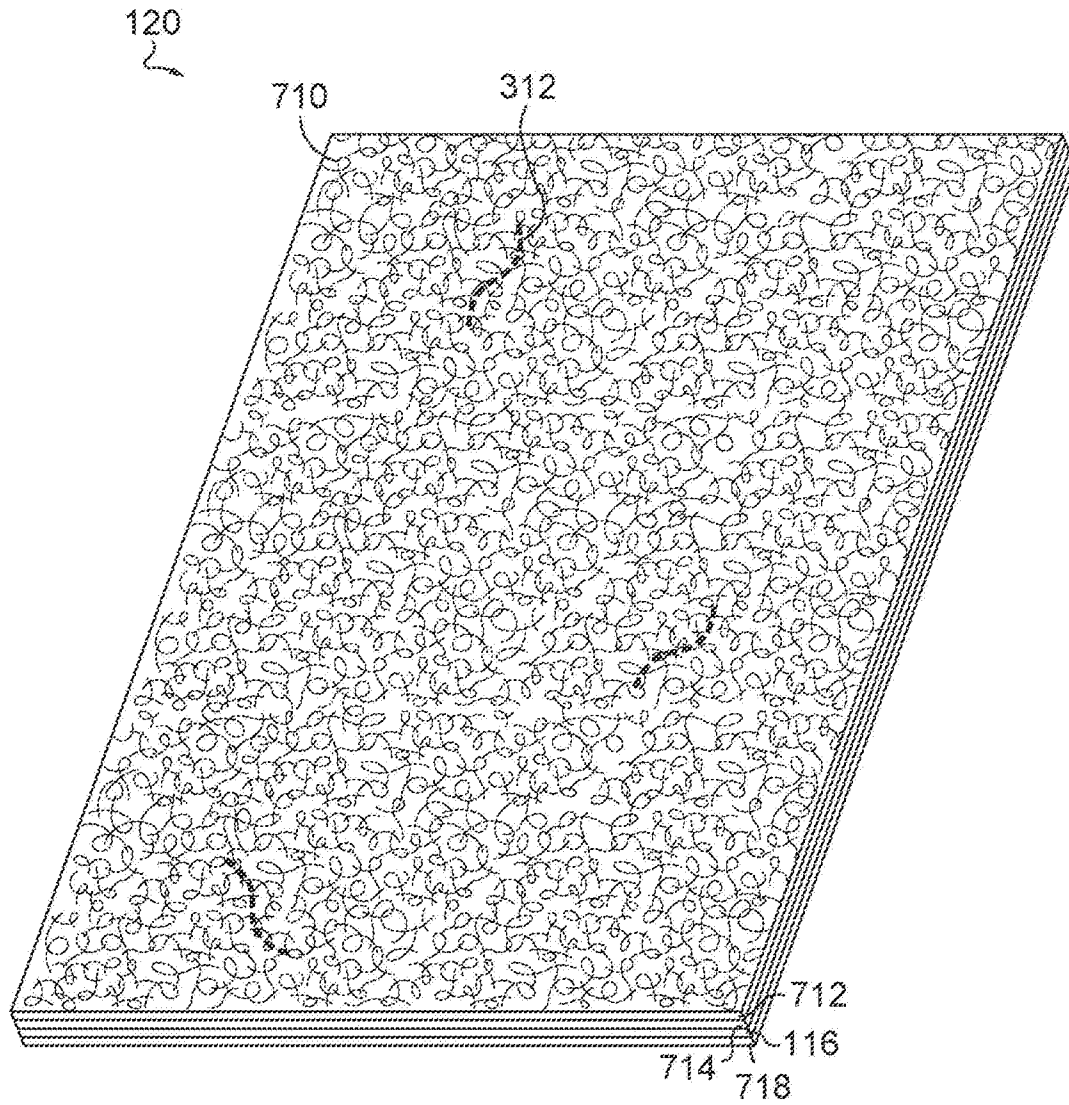

[ Fig. 8 ]

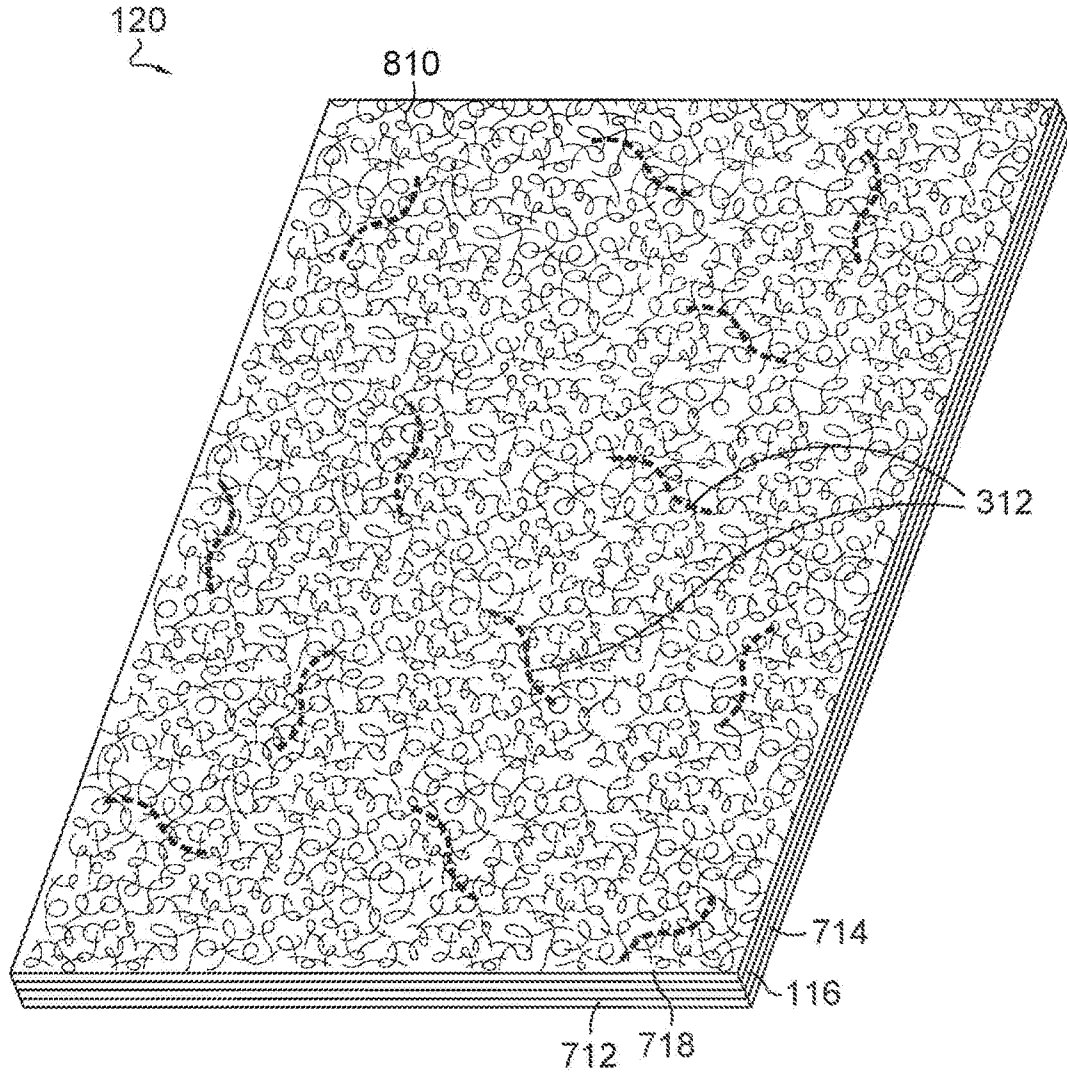

[ Fig. 9 ]

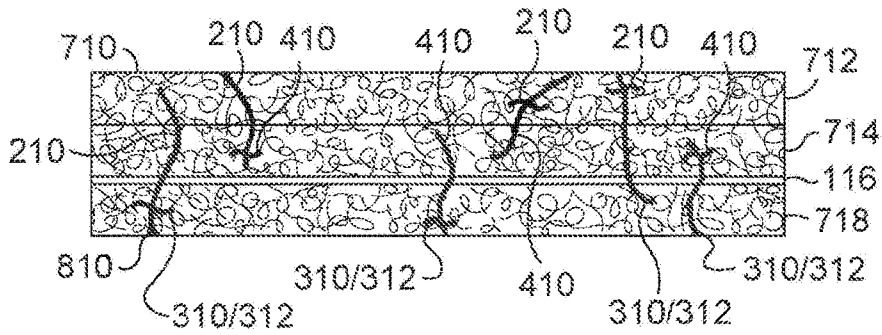

[ Fig. 10 ]

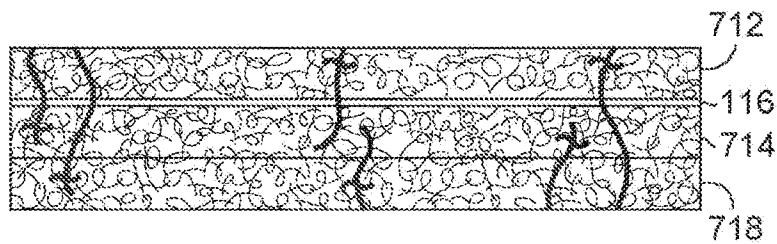

[ Fig. 11 ]

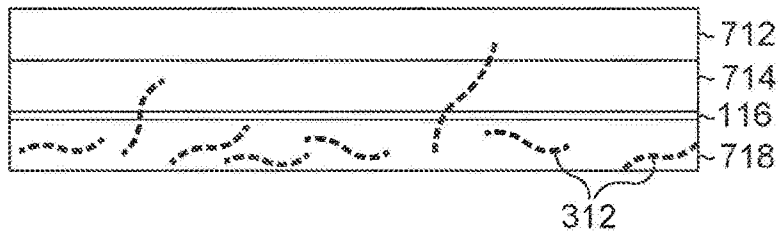

[ Fig. 12 13 ]

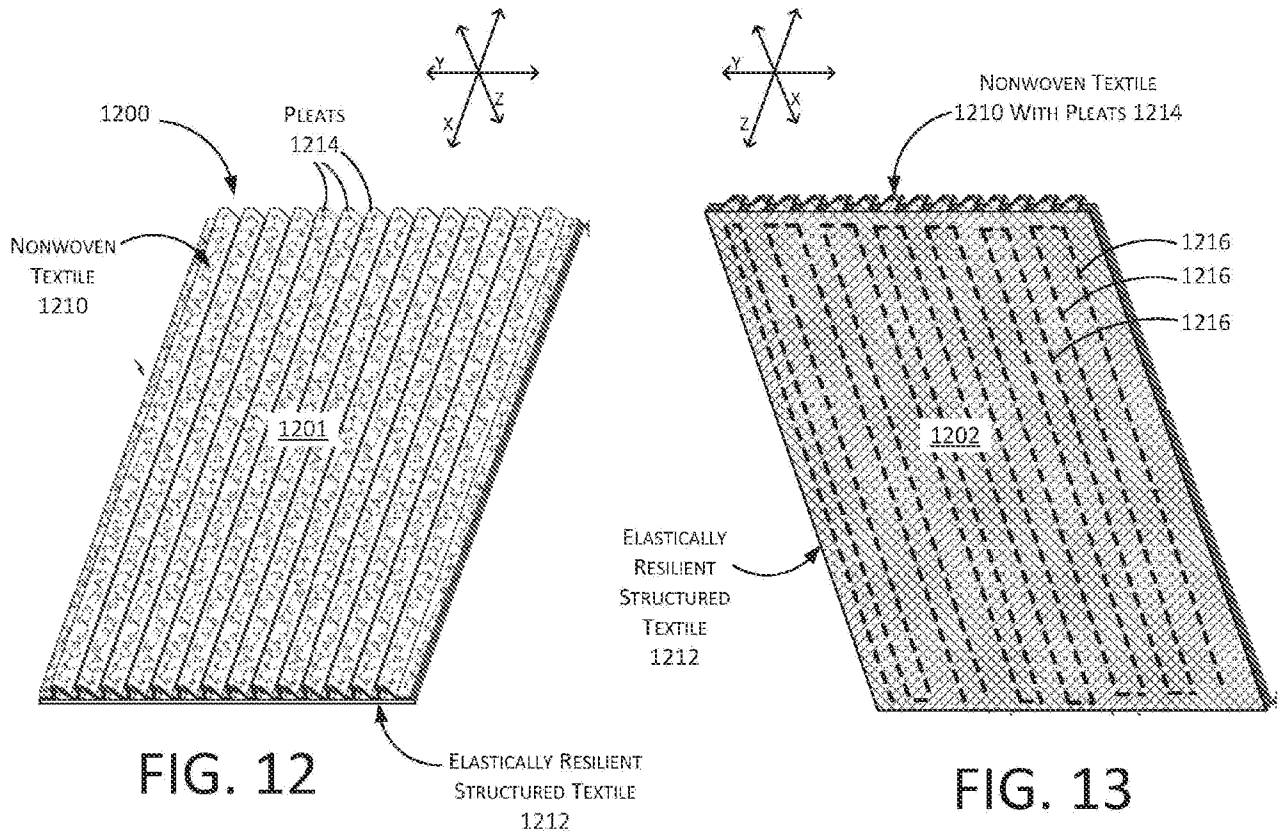

[ Fig. 14 ]

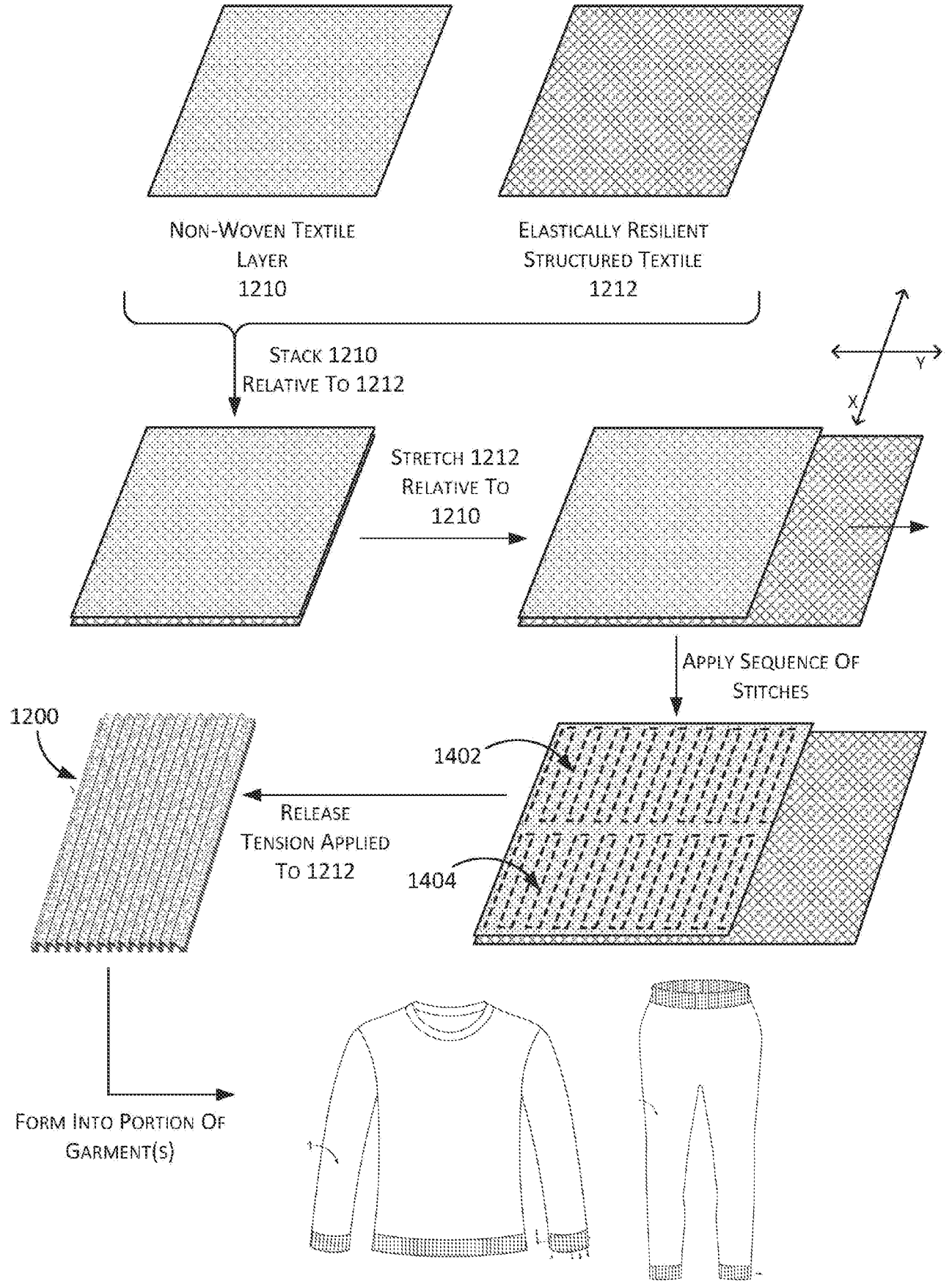

[ Fig. 15]

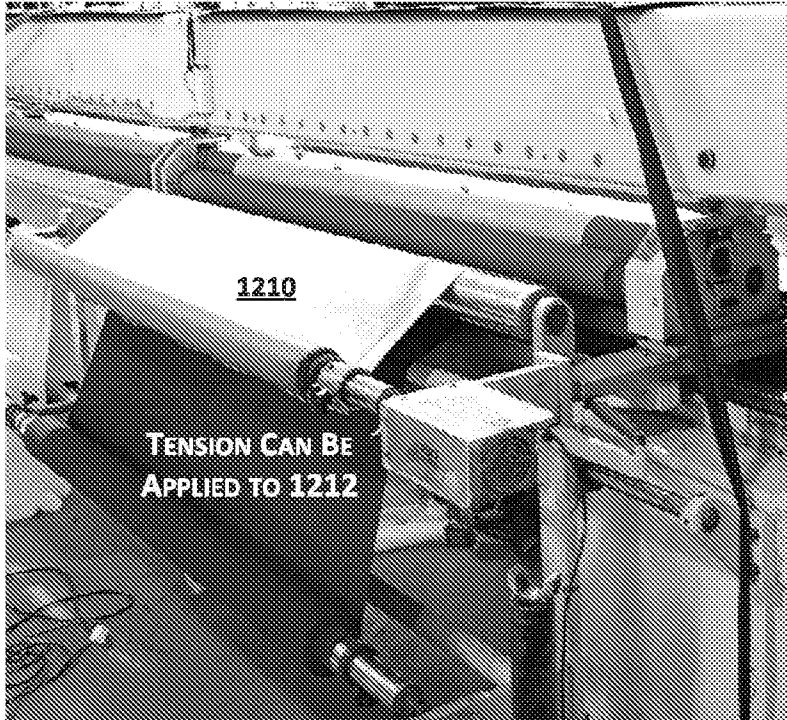

Note: Layer 1212 is the black rolled good and layer 1210 is the lighter colored rolled good.

Rule 26,  
01.08.2023

[ Fig. 16]

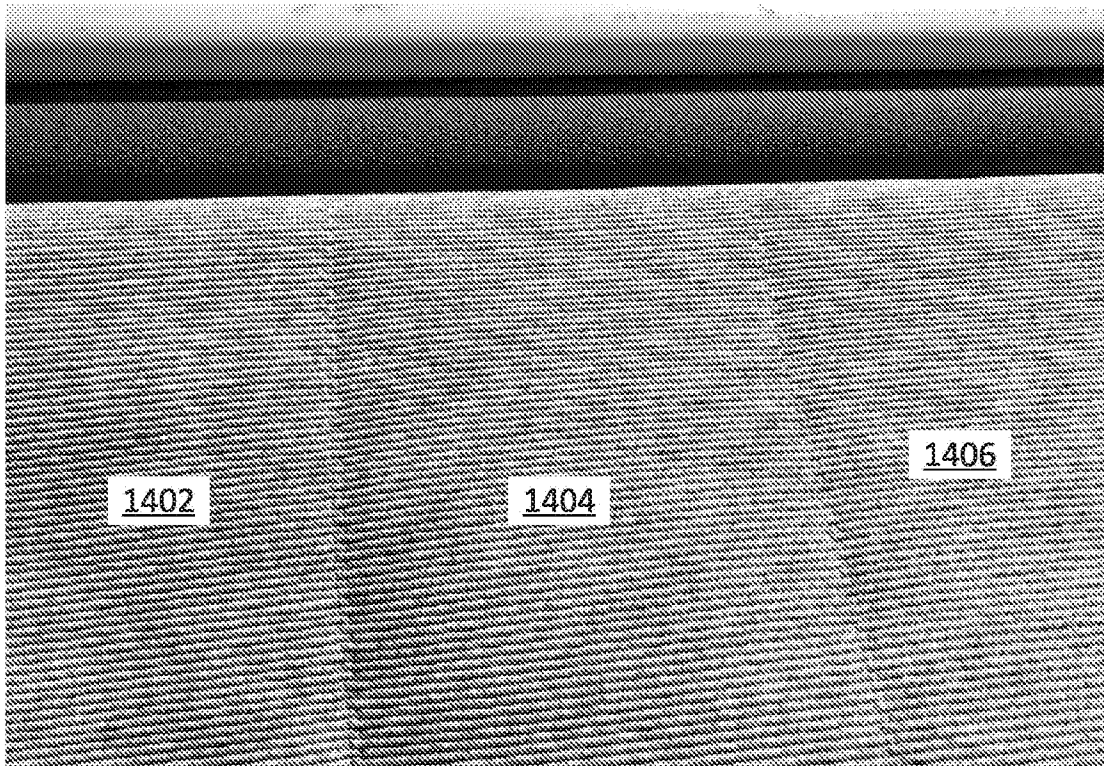

One or more needles apply stitches in a sequence/series (e.g., serpentine-like)

Rule 26,  
01.08.2023

[ Fig. 17]

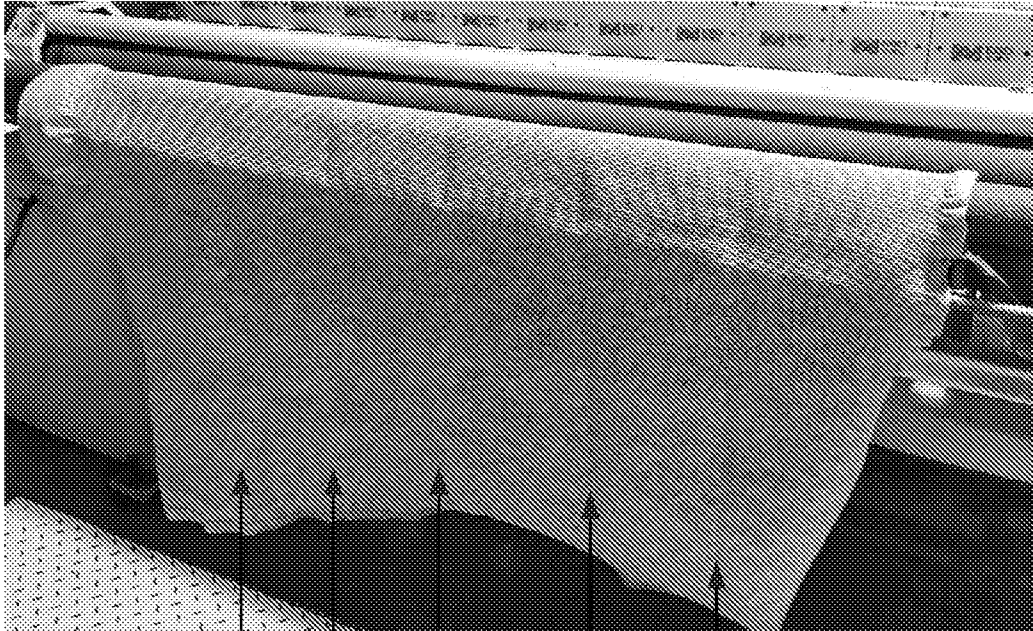

Each section can be cut away along the margin to form a separate ribbed panel

[ Fig. 18]



[ Fig. 19]

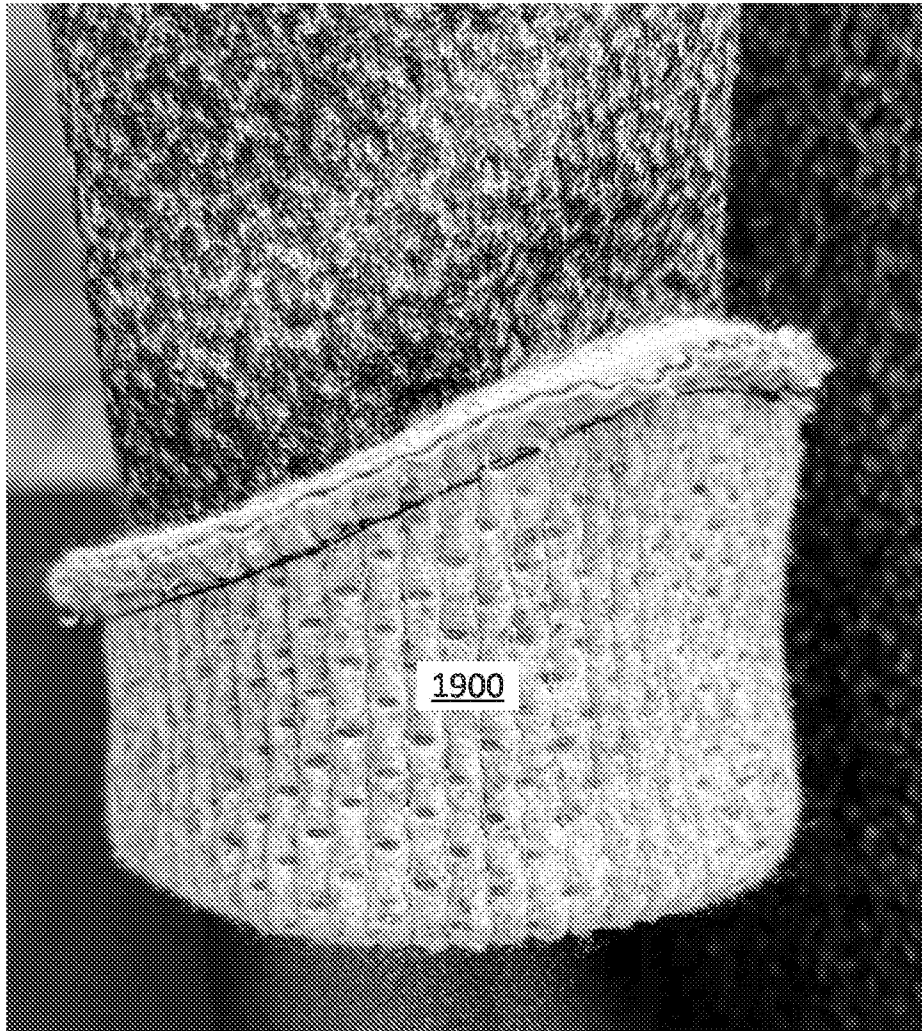

Rule 26,  
01.08.2023

# INTERNATIONAL SEARCH REPORT

International application No <b>PCT/CN2023/098315</b>
----------------------------------------------------------

<b>A. CLASSIFICATION OF SUBJECT MATTER</b>		
INV. <b>B32B5/06</b>	<b>B32B7/09</b>	<b>B32B5/26</b>
ADD. <b>D06J1/00</b>	<b>B32B5/02</b>	<b>A41D31/18</b>
According to International Patent Classification (IPC) or to both national classification and IPC		
<b>B. FIELDS SEARCHED</b>		
Minimum documentation searched (classification system followed by classification symbols) <b>B32B A41D D06J</b>		
Documentation searched other than minimum documentation to the extent that such documents are included in the fields searched		
Electronic data base consulted during the international search (name of data base and, where practicable, search terms used) <b>EPO-Internal</b>		
<b>C. DOCUMENTS CONSIDERED TO BE RELEVANT</b>		
Category*	Citation of document, with indication, where appropriate, of the relevant passages	Relevant to claim No.
<b>X</b>	<b>US 2021/114345 A1 (TORONJO ALAN [US] ET AL) 22 April 2021 (2021-04-22) paragraphs [0035], [0036], [0046], [0067]; figures 3, 4C</b> -----	<b>1-28</b>
<b>A</b>	<b>US 2006/162050 A1 (KAUFMAN REBECCA A [US] ET AL) 27 July 2006 (2006-07-27) abstract</b> -----	<b>1-28</b>
<b>A</b>	<b>WO 2022/093594 A2 (NIKE INNOVATE CV [US]; NIKE INC [US]) 5 May 2022 (2022-05-05) claim 11; figures 1-10</b> -----	<b>1-28</b>
<b>A</b>	<b>WO 2023/024022 A1 (NIKE INNOVATE CV [US]; NIKE INC [US]) 2 March 2023 (2023-03-02) figures 1-6, 19-21</b> -----	<b>1-28</b>
<input type="checkbox"/> Further documents are listed in the continuation of Box C. <span style="margin-left: 100px;"><input checked="" type="checkbox"/> See patent family annex.</span>		
* Special categories of cited documents :		
"A" document defining the general state of the art which is not considered to be of particular relevance	"T" later document published after the international filing date or priority date and not in conflict with the application but cited to understand the principle or theory underlying the invention	
"E" earlier application or patent but published on or after the international filing date	"X" document of particular relevance; the claimed invention cannot be considered novel or cannot be considered to involve an inventive step when the document is taken alone	
"L" document which may throw doubts on priority claim(s) or which is cited to establish the publication date of another citation or other special reason (as specified)	"Y" document of particular relevance; the claimed invention cannot be considered to involve an inventive step when the document is combined with one or more other such documents, such combination being obvious to a person skilled in the art	
"O" document referring to an oral disclosure, use, exhibition or other means	"&" document member of the same patent family	
"P" document published prior to the international filing date but later than the priority date claimed		
Date of the actual completion of the international search	Date of mailing of the international search report	
<b>16 November 2023</b>	<b>30/11/2023</b>	
Name and mailing address of the ISA/ European Patent Office, P.B. 5818 Patentlaan 2 NL - 2280 HV Rijswijk Tel. (+31-70) 340-2040, Fax: (+31-70) 340-3016	Authorized officer  <b>Saunders, Thomas</b>	

# INTERNATIONAL SEARCH REPORT

Information on patent family members

International application No

PCT/CN2023/098315

Patent document cited in search report	Publication date	Patent family member(s)	Publication date
US 2021114345 A1	22-04-2021	US 2021114345 A1	22-04-2021
		US 2022118738 A1	21-04-2022
-----			
US 2006162050 A1	27-07-2006	NONE	
-----			
WO 2022093594 A2	05-05-2022	NONE	
-----			
WO 2023024022 A1	02-03-2023	CN 115726099 A	03-03-2023
		CN 115726100 A	03-03-2023
		CN 218812488 U	07-04-2023
		CN 218812489 U	07-04-2023
		TW 202310765 A	16-03-2023
		TW 202325173 A	01-07-2023
		WO 2023024022 A1	02-03-2023
-----			