

19



Europäisches Patentamt
European Patent Office
Office européen des brevets



11 Publication number:

0 319 248 B1

12

EUROPEAN PATENT SPECIFICATION

45 Date of publication of patent specification: 23.06.93 51 Int. Cl.⁵: G08B 13/24

21 Application number: 88311299.7

22 Date of filing: 29.11.88

54 Economic, multi-directionally responsive marker for use in electronic article surveillance systems.

30 Priority: 30.11.87 US 126749

43 Date of publication of application:
07.06.89 Bulletin 89/23

45 Publication of the grant of the patent:
23.06.93 Bulletin 93/25

64 Designated Contracting States:
BE CH DE ES FR GB IT LI NL SE

56 References cited:
GB-A- 2 148 668
US-A- 3 790 945
US-A- 3 938 125
US-A- 4 222 517
US-A- 4 527 152

73 Proprietor: MINNESOTA MINING AND MANUFACTURING COMPANY
3M Center, P.O. Box 33427
St. Paul, Minnesota 55133-3427(US)

72 Inventor: Eisenbels, Clyde T. c/o Minnesota Mining and Manufacturing Company 2501 Hudson Road P.O. Box 33427 St. Paul Minnesota 55133(US)

74 Representative: Baillie, Iain Cameron et al
c/o Ladas & Parry, Althelmer Eck 2
W-8000 München 2 (DE)

EP 0 319 248 B1

Note: Within nine months from the publication of the mention of the grant of the European patent, any person may give notice to the European Patent Office of opposition to the European patent granted. Notice of opposition shall be filed in a written reasoned statement. It shall not be deemed to have been filed until the opposition fee has been paid (Art. 99(1) European patent convention).

Description

Technical Field

This invention relates to electronic article surveillance (EAS) systems and markers used therein, and in particular, to such markers in which the magnetization of a piece of magnetic material in the marker is changed by an alternating magnetic field in an interrogation zone to produce detectable signals indicating the presence of the marker.

Background Art

It is now well known to utilize a piece of low coercive force, high permeability magnetic material as an EAS marker. Such markers were perhaps first disclosed in the French Patent No. 763,681, issued in 1934 to Pierre Arthur Picard. More recently, it has become relatively well known to use particularly configured pieces, such as elongated strips of high permeability material, in order to enhance the production of very high order harmonics, thereby improving the reliability with which such markers can be distinguished over signals from other articles such as briefcase frames, umbrellas, etc. Such uses are exemplarily set forth in U.S. Patent Nos. 3,665,449, 3,790,945 and 3,747,086. As such elongated strips are generally detectable only when the interrogating field is aligned with the strips, it is also known from such disclosures to provide for multi-directional response by providing multi-directional fields in the interrogation zone and by providing additional strips in an L, T or X configuration. Alternatively, in U.S. Patent No. 4,074,249 (Minasy), it is proposed that multi-directional response may be obtained by making the strip crescent-shaped. Furthermore, it is known from U.S. Patent No. 4,249,167 (Purinton et al.) to make a deactivatable multi-directionally responsive marker by providing two elongated strips of permalloy arranged in an X configuration with a few hard magnetic pieces adjacent and co-linear to each of the permalloy strips.

While still recognizing that an elongated, or "open-strip" configuration is desired in order to obtain a very high order harmonic response, U.S. Patent No. 4,075,618 (Montean) discloses that a marker capable of generating very high order harmonics, thereby being operative in a system such as described in the '449 patent, could be made by adding flux collectors to a short strip of high permeability material which is insufficiently long to meet the definition of an "open-strip". Picard also suggests that polar extensions may be provided to increase the sensitivity, while Fearon '945 suggest the use of pole piece coupons to collect flux.

Markers such as disclosed by Elder, Fearon, Peterson, Minasy and Montean in the above patents have all enjoyed certain commercial success. However, the use of the markers has been restricted by the size, and still primarily elongated shape heretofore believed to be necessary.

EAS systems in which the markers of the present invention are particularly useful typically produce within the interrogation zone fields in a variety of directions. For example, as disclosed in U.S. Patent No. 4,300,183 (Richardson), such differently directed fields may be produced by providing currents in coils on opposite sides of the interrogation zone which are alternately in-phase and out-of-phase. The resulting aiding and opposing fields at any given location may be appreciably weaker in one direction than another. Accordingly, a given marker may be unacceptable if reliably detectable only when oriented in the direction associated with the strongest fields produced by the EAS system. Preferably, a commercially viable marker would have sensitivity so as to be reliably detectable regardless of how it is oriented in the zone, however, in a practical sense, it is not necessary to detect markers in each and every orientation and/or location in the zone.

Typical EAS systems designed to be used with elongated "open-strip" type markers are the Model WH-1000 and 1200 systems marketed by Minnesota Mining and Manufacturing Company. For example, such systems typically produce within the interrogation zones magnetic fields alternating at 10 kHz, and having minimum intensities at the center of the zone of approximately 96 A/m when the fields generated in coils on opposite sides of the zone are in an opposing configuration and of approximately 192 A/m when in an aiding configuration. The receiver portions of such systems process signals from receiver coils positioned within panels adjacent to the interrogation zone, and activate an alarm circuit in the event signals corresponding to very high order harmonics of the applied field are detected.

To compare the performance of various markers, it is convenient to use a test apparatus which generates fields alternating at a predetermined frequency and has controllable strength comparable to those encountered in such EAS systems. The test apparatus should detect signals in accordance with the harmonic characteristics relied upon in such systems and provide sensitivity values, based on a standard marker to ensure valid comparative results.

Such a test apparatus is preferably calibrated against a present commercially available marker such as type WH-0117 Whispertape brand detection strip manufactured by Minnesota Mining and Manufacturing Company, which is formed of an amorphous metal 6.7 cm long, 1.6 mm wide and 0.02 mm thick and having the following nominal composition (at %): Co:69%; Fe:4.1%; Ni:3.4%; Mo:1.5%; Si:10%; and B:12%, and which is available from Allied-Signal Corporation as type 2705M. Such a marker is inserted parallel with the field of the test apparatus and the gain is adjusted to indicate a standardized sensitivity value of 1.0 at a 10 kHz field of 96 A/m that being the minimum field strength at which such a marker would be expected to be reliably detected. At a higher field of 112 A/m, a sensitivity of 4.8 was observed when the amorphous marker was similarly aligned.

It has long been desired to minimize the length of such elongated markers. However, short strips do not have sufficient sensitivity to be even marginally acceptable even at a high field strength and even when dimensioned to maximize high order harmonic response. Similarly, when short pieces are further dimensioned with polar extensions proportional to that depicted in Figure 7 of Picard, in which the length of the center section is about eight times the center width and the overall length about 13 times the center width, the sensitivity is still unacceptable. For example, a 0.02 mm thick ribbon of the amorphous metal described above was cut to provide 2.5 cm long strips 1.6 mm, 0.8 mm and 0.5 mm wide. Also, a 2.5 cm long piece, 1.6 mm wide was provided with polar extensions according to "Picard". Relative sensitivities shown in the following table were then determined using the same procedure described above.

Field Strength A/m	"Picard" marker with polar extensions on each end of a 1.6 mm wide strip	Strip Width (mm) and (L/\sqrt{A} ratio)		
		1.6 (140)	0.08 (198)	0.5 (250)
96	0.02	0.014	0.034	0.037
192	0.26	0.18	0.18	0.017
240	0.46	0.28	0.25	0.025

It may thus be recognized that regardless of whether the strips were made very narrow, thus minimizing the demagnetization effects, or were made wider, thus providing a greater total mass, in all cases an unacceptable sensitivity level resulted. While the standardized sensitivity values of 0.02, 0.26 and 0.46 observed at the three field strengths noted above for the "Picard" type marker were superior to that observed for a strip alone, showing that increases in sensitivity do result by adding polar extensions as taught by the prior art, such benefits are still not sufficient to result in even a marginally acceptable marker.

Disclosure of Invention

In contrast to the elongated "open-strip" markers described above, wherein a desired high order harmonic response was obtained by keeping the length to square foot of cross sectional area above a certain minimum, and wherein a multi-directional response was suggested by combining such "open-strips" in an "X" or "L" configuration, the marker of the present invention obtains a high order harmonic, multi-directional response without requiring strips of the "open-strip" dimensions to be present. The present marker employs a plurality of short strips in which pairs of the strips are positioned parallel to each other at opposite sides of a closed planar shape, such as a square. Preferably, the ends of each strip are positioned to just overlap with the outside edge of an intersecting strip, however, the strips may also be inset a distance of up to 25% of the overall length, thus forming a "tic-tac-toe" configuration. The intersecting strips are magnetically coupled together. Accordingly, a first pair of pieces adjacent the opposite ends of a second pair of pieces collect and concentrate flux associated with a field parallel to the second pair of pieces within the second pair. Furthermore, with such a configuration, a multi-directional response is obtained, as flux associated with a field at an angle to the first field, and hence parallel the aforementioned first pair of pieces, will now be collected and concentrated by the second pair of pieces.

Each respective pair of pieces may function as flux collectors if appropriately aligned with respect to an external magnetic field, or will alternatively function as switching sections to generate the desired very high order harmonic response so long as the adjacent flux collecting pieces collect and concentrate a significant amount of flux. By so concentrating the magnetic flux, the effective flux density is increased so that the magnetization in switching pieces is very rapidly reversed upon each reversal of the applied field and very high order harmonics are generated at a given applied field intensity. It has also been found that the signals produced by such markers, while containing very high order harmonics upon which detection can be

reliably based, also contain various other isolatable characteristics making the markers useful in other systems in which harmonics per se may not be isolated.

The magnetic pieces comprising the present marker preferably have overall lengths in the range between 10-40mm and widths in the range between 0.8 to 4.8mm, and preferably are formed of thin sheets, foils or ribbons ranging in thickness between 0.01 to 0.05mm. The above dimensions are provided only as a guide, and are not critical. Longer and narrower pairs of pieces behave more like "open-strips", hence the flux gathering benefits of the other pair of pieces become less necessary, however, the marker becomes objectionably large for many applications. Alternatively, while shorter pieces with flux collectors may be better for those applications, size reductions will ultimately preclude the generation of an acceptably detectable signal.

The pieces are desirably formed of high permeability, low coercive force magnetic materials such as permalloy, supermalloy or the like and of analogous amorphous materials such as the Metglas® alloys 2826MB2 and 2705M, etc. manufactured by Allied-Signal Corporation, and the Vitrovac® alloys 6025X, 6025Z-2, etc., manufactured by Vacuumschmelze GmbH.

A marker such as described above is conveniently made dual-status, i.e., reversibly deactivatable and reactivatable by including at least one piece of remanently magnetizable material adjacent the high permeable, low coercive force pieces, which piece when magnetized provides fields which bias the magnetization of the adjacent low coercive force piece to alter the response of the marker resulting from the alternating magnetic field encountered in the interrogation zones.

Brief Description of Drawings

Figure 1 is a perspective view of one embodiment of a deactivatable marker of the present invention;

Figure 2 is a top view of another embodiment of the marker of the present invention;

Figure 3 is a perspective view of another deactivatable marker according to another embodiment of the present invention;

Figure 4 illustrates a method for economically producing the markers of the present invention;

Figure 5 is a partial top view of a sheet containing a number of as yet unseparated markers made according to the method of Figure 4; and

Figure 6 is a side view taken along the line 6-6 in Figure 5.

Detailed Description

As shown in the perspective view of Figure 1, in one embodiment of the present invention the marker 10 comprises a substrate 12 on which are positioned four strips, 14, 16, 18 and 20 respectively, of a low coercive force, high permeability material, such as permalloy. As is also there shown, each of the strips is positioned so as to be magnetically coupled to an intersecting strip near the respective ends. As the operation of the marker is largely dependent upon the extent of magnetic coupling between the intersecting strips, it is desirable that the strips at the points of intersection be positioned as closely together as possible. Accordingly, while the strips may be joined together via a thin layer of adhesive, it is preferred that each of the strips be adhered to the supporting substrate 12 such that no adhesive is at all present between the strips at the respective points of intersection. If further desired, a protective overlayer (not shown) may be added and further adhered to the substrate 12 so as to sandwich the strips therebetween, and further press the strips together at the respective intersections.

In the embodiment of Figure 1, the marker 10 is further made dual status so as to be selectively deactivatable and reactivatable. Such a feature is provided by including with each of the strips 14, 16, 18 and 20 respectively at least one section, of a remanently magnetizable material such as vicalloy. Thus as shown in Figure 1, strip 14 is provided with two pieces 22 and 24 of vicalloy, strip 16 is provided with two such pieces 26 and 28, strip 18 is provided with two pieces 30 and 32 and strip 20 is provided with two pieces 34 and 36. In a manner similar to that discussed above, the magnetizable pieces must be magnetically coupled to the adjacent low coercive force, high permeability pieces such that when the magnetizable pieces are magnetized, the external magnetic field associated with the magnetized state of each piece is coupled to the adjacent high permeability piece so as to bias that piece and affect the magnetization reversal of that piece when the marker is exposed to the alternating field typically present in an interrogation zone. Thus each of the magnetizable pieces are desirably positioned on top of the high permeability piece without an intervening adhesive layer, however, such a layer may be present, and the total assembly maintained in position via an adhesively bonded top cover layer (not shown).

In a preferred construction, a marker of Figure 1 desirably has overall dimensions approximately 2.54 cm square. Thus the substrate 12 may be provided of a dielectric sheet such as Kraft paper, relatively stiff plastic or the like. Each of the high permeability pieces 14 through 20 is desirably a strip of permalloy approximately 2.54 cm long and 2.5 mm wide, such strips being cut from a sheet of such material 15 μ m thick. In such a construction, the magnetizable pieces 22 through 36 are small rectangles of vicalloy having approximately the same width (2.5 mm) and a length extending along the length of each of the underlying strips of approximately 0.6 mm. Such chips are readily cut from a sheet of such a material.

The performance of the marker as shown in Figure 1 is strongly effected by the magnetic coupling at the intersections of the adjoining strips. Thus, the strips may be joined at the respective intersections by a thin layer of pressure-sensitive adhesive or the like. However, it is preferable that the gap resulting from such an adhesive layer be maintained as thin as possible. In a more preferred construction, a layer of pressure-sensitive adhesive may be utilized to adhere each of the respective strips directly to the substrate 12 such that the strips are in intimate physical contact at the intersecting locations without any adhesive or the like separating the respective strips. Furthermore, also not shown in Figure 1, a top protective layer may be added to both protect the strips, provide a printable surface for suitable customer identification indicia to be added and further, as it may be directly bonded to the substrate 12 to press the respective strips together at the intersections, so as to further improve the extent of magnetically coupling.

In order to demonstrate the effectiveness of a "tic-tac-toe" configuration such as shown in Figure 1, a series of experiments were performed in which strips of constant length but varying width foils were assembled, with varying amounts of each strip overlapping the ends of the adjacent intersecting strip. Specifically, strips of an amorphous material, type 2705M obtained from Allied-Signal Corporation, which material has the following nominal composition (at %): Co:69%; Fe:4.1%; Ni:3.4%; Mo:1.5%; Si:10% and B:12%, 0.8 mils thick, were prepared in strips of 2.54 cm long and in widths ranging in 0.51 mm increments from 0.51 to 3.05 mm. These strips were assembled in three sets, one set having the ends directly abutting so that there was no material extending beyond the intersections, while the second and third sets had 2.5 mm and 5.1 mm of the material extending beyond the intersections, respectively. Such sample markers were then tested in the aforescribed apparatus which generates alternating fields at a predetermined frequency and intensities comparable to those encountered in electromagnetic article surveillance (EAS) systems. This apparatus was constructed to detect signals in accordance with harmonic characteristics relied upon in such EAS systems and to provide sensitivity values based on a standard marker to ensure valid comparative results. Such a standard marker is desirably formed of a strip of the same composition, amorphous metal foil, 6.67 cm long by 1.59 mm wide by 20.3 μ m thick.

When such a marker was inserted parallel with the field of test apparatus and the gain was adjusted to a standardized sensitivity, a sensitivity value of approximately 4 volts at a peak field intensity of 160 A/m was obtained. To provide a direct comparison with the 2.54 cm long strips used in the samples of the present invention, such a standardized marker was then cut to a length of 2.54 cm and the equivalent sensitivity at a peak intensity of 160 A/m was determined to be 0.08 volts. Similarly, when two such 2.54 cm long strips were assembled side-by-side and spaced approximately 2.54 cm apart but without a pair of opposing and magnetically coupled intersecting strips present, the sensitivity of the two strips was not quite double that previously observed, i.e., a sensitivity value of about 0.13 volts was observed. The resultant sensitivities observed for the series of markers of varying widths and varying amounts of overlap are set forth below in Table I. These markers were prepared with each adjacent metal strip being in intimate ohmic contact with the intersecting piece. Furthermore, two markers of each dimension were prepared and each was measured in the test apparatus by first inserting the marker along to have one pair of strips parallel to the applied field, then by removing it, rotating it 90° and inserting it so that the other pair of strips was parallel to the applied field. The measured sensitivity values for all four cases were then averaged. The average results are indicated in Table I.

As noted above, the response of a single elongated strip, such as used in forming the "tic-tac-toe" marker, is known to be extremely sensitive to the extent of elongation, such an extent being generally characterized by the ratio of the length over the square root of the cross sectional area (L/\sqrt{A}). Thus, for example, the L/\sqrt{A} ratio for the standardized 6.67 cm long marker is approximately 370, which is known to produce a readily highly detectable signal. In contrast, the 2.54 cm strip of such a piece has an equivalent ratio of about 140, which is less than that required to produce an adequate signal. The equivalent ratio for the strips in the samples set forth in Table I is there indicated. The effect of providing the flux collectors at right angles may be seen in Table I to raise the corresponding sensitivity from 0.13 up nearly a factor of 5 when the respective strips were inset a distance of 0.51 mm, and nearly a factor of 7 when the strips were positioned with 0 extensions.

Table I

Extension Beyond End of Strips						
Width of Strips (mm)	0		2.54 mm		5.1 mm	
	L/\sqrt{A}	Sensitivity	L/\sqrt{A}	Sensitivity	L/\sqrt{A}	Sensitivity
0.51	277	1.04	219	0.81	162	0.61
1.02	188	0.72	147	0.69	106	0.56
1.52	147	0.85	113	0.69	80	0.58
2.03	121	0.88	92	0.66	63	0.51
2.54	103	0.72	77	0.67	52	0.48
3.05	90	0.86	66	0.64	42	0.43

The effect of efficiently coupling the pieces together at the intersections is further set forth in Table II in which 1.52 mm wide, 2.54 cm long strips of the same material as used in the previous examples were assembled with zero extensions at the intersections but in which varying thicknesses of adhesive were provided separating the adjoined pieces. As shown, when as much as 0.25 mm thick layer of adhesive separated the intersecting pieces, the resultant sensitivity was decreased nearly to the extent noted above, wherein two pieces of the same length were placed 2.54 cm apart side-by-side and no intersecting flux collectors were present.

Table II

Adhesive Thickness (mm)	Sensitivity
0	0.85
0.025	0.46
0.076	0.35
0.25	0.22

An alternative embodiment to that described in Figure 1 is set forth in Figure 2, wherein the four strips 40, 42, 44, and 46 of high permeability, low coercive force material were assembled as noted above with approximately 20% of the entire width of each strip extending beyond the intersections of an intersecting strip. In this embodiment, a single magnetizable element 48, 50, 52 and 54 respectively was positioned at the center of each of the strips 40 through 46. While such a configuration has been found to produce a significant change in the sensitivity of the resultant marker depending upon whether or not the magnetizable elements 48 through 54 are in fact magnetized or not, the change in the resultant response was found not to be as significant as found when two such materials are provided on each strip as shown in Figure 1.

A yet more desirable embodiment is shown in Figure 3 wherein elongated strips 56, 58, 60 and 62 are shown assembled on an underlying substrate 64 as in Figure 1 but wherein magnetizable elements 66, 68, 70 and 72 are positioned at the intersections of each of the respective strips. In an embodiment in which a 1.52 mm wide strips of 2.54 cm long amorphous metal as described above were assembled with zero adhesive between the adjoining strips, the sensitivity in a 160 A/m field was observed to be about 0.8 volts, and, the presence of an unmagnetized 4.76 mm square chip of vicalloy at each intersection was found to not result in any observable change in the sensitivity. The same marker, but with 6.35 mm square vicalloy chips at each of the four intersections was observed to have a slightly lower sensitivity of 0.49 volts. When the vicalloy chips were magnetized, it was found that the signals from the markers were at least two orders of magnitude less intense.

Mass produced multi-directionally responsive markers of the present invention are desirably made by a series of laminating and slitting operations. Thus, for example, as shown in Figure 4, rolls 74, 76, 78, 80, 82 and 84 respectively, of high permeability material having the appropriate width and thickness, such as 1.52 mm wide and 0.015 mm thick rolls of permalloy, are provided with a layer of pressure-sensitive adhesive on the bottom surface. The respective rolls 74 and 76, and 78 and 80, are positioned at a center-to-center distance of 2.54 cm from each other, with the distance between the rolls 76 and 78 and 82 and 84 being adjusted to control the extent of desired extension at the intersections of the adjacent strips of the markers to be formed. As shown, the material on the rolls 74 through 80 and a support web from roll 90 are passed

between rollers 86 and 88, causing the respective strips to adhere to the support web. The rolls 82 and 84 are similarly positioned and in a start-stop operation, the material from those rolls is also adhered to the support. A hopper containing 2.54 cm square chips 91 of vicalloy is positioned down-web and suitably activated to thereafter position squares of that material as there shown. Markers 92, 94, 96 and 98 were thus formed, albeit not yet separated.

As further shown in the top view of Figure 5, the resultant laminations may be subsequently separated by shearing along the dashed lines 100, 102, 104 and 106 respectively. In a particularly preferred embodiment, where rolls of the resultant markers are desirably provided, a full cut through the support web 90 may be provided along the cut lines 100 and 102, while the web is left only partially severed along cut lines 104 and 106, thus allowing the resultant markers to be dispersed in roll form and subsequently broken apart while the magnetic material is completely severed at the respective shear lines 104 and 106.

Further details of the resultant strips after the final laminates are formed are shown in the cross sectional view of Figure 6, taken along the lines 6-6 of Figure 5. In Figure 6 it may be seen that the top surface of the metal strips 74, 76, 78, 80 and 82A are covered by a protective top layer 108 which also forces the pieces of high coercive force magnetizable materials 91 into close magnetic coupling with the intersecting strips of high permeability, low coercive force material. Likewise, the piece 108 will thus be similarly secured to the underlying support 90 in the regions where no strips occur, resulting in a tightly bonded together, finished construction, having both upper and lower surfaces suitable for the addition of customer indicia.

In the multi-directionally responsive markers described above with regard to Figures 4-6, keeper chips 91 are shown to have been placed above the intersections of each of the adjoining strips of low coercive force, high permeability material. When the keeper chips are magnetized, the external field associated therewith prevents the magnetization in the portions of the strips adjacent the keeper chips from reversing, thereby both eliminating any flux collecting action on the part of the strips normal to an applied field of an interrogation zone and appreciably shortening the length of the strips that are parallel to the applied field such that a non characteristic response thus occurs. While such an embodiment is preferably due to the high level of desensitization thus produced, it is similarly within the scope of the present invention that a single or multiple keeper chips may be disposed along the length of each of the elongated strips as set forth in Figures 1 and 2.

While the markers described above with regard to the preferred embodiments of the present invention are desirably made of an amorphous alloy of a given composition, it is also within the scope of the present invention that a number of high permeability, low coercive force materials may be used. Thus, for example, a number of amorphous alloys, both iron and nickel based, as well as the cobalt based alloy described above, may be utilized, as may be a large variety of crystalline materials, such as permalloy, supermalloy and the like. Similarly, the material used as the keeper chips may be formed of a variety of permanently magnetizable, yet relatively low coercive force materials. While vicalloy has been described hereinabove as a preferred material, similar chips for desirable markers may be formed of silicon steel, magnetic stainless steels, and the like.

Claims

1. A marker for use in an electronic article surveillance system of the type in which an alternating magnetic field in an interrogation zone produces remotely detectable magnetization changes in the marker, wherein the marker comprises at least two pairs (14 and 18, and 16 and 20; 40 and 42 and 44 and 46; 56 and 60 and 58 and 62) of strips of a high permeability, low coercive force, magnetic material, both pairs of strips being positioned in substantially the same plane, with the strips of each pair being positioned to be substantially parallel to each other and intersecting with the strips of the other pair and dimensioned so as to overlap and be magnetically coupled therewith, the extent of such overlap being such that less than 25% of the length of each strip extends beyond the side of an intersecting strip of another pair, the strips of a first pair thereby forming flux collectors to concentrate flux from fields extending substantially parallel to the strips of the second pair into the strips of the second pair.
2. A marker according to claim 1, wherein all of said strips are substantially the same dimension.
3. A marker according to claim 1, wherein all of said strips are substantially the same composition.

4. A marker according to claim 1, further comprising at least one section (22, 24, 26, 28, 30, 32, 34, 36; 48, 50, 52, 54; 66, 68, 70, 72) of permanently magnetizable material positioned adjacent to each of said strips, and magnetically coupled thereto such that when so magnetized the detectable response resulting from the marker is altered.
5. A marker according to claim 4, wherein a piece (66, 68, 70, 72) of permanently magnetizable material is positioned over the intersections of said strips.

Patentansprüche

10

1. Etikett zur Verwendung in einem elektronischen Artikelüberwachungssystem der Art, bei der ein wechselndes Magnetfeld in einer Abfragezone aus der Ferne erfaßbare Änderungen der Magnetisierung in dem Etikett erzeugt, dadurch gekennzeichnet, daß das Etikett mindestens zwei Paare (14 und 18 sowie 16 und 20; 40 und 42 sowie 44 und 46; 56 und 60 sowie 58 und 62) von Streifen aus einem magnetischen Material mit hoher Permeabilität und niedriger Koerzitivfeldstärke umfaßt, und beide Streifenpaare sind im wesentlichen in derselben Ebene angeordnet, wobei die Streifen von jedem Paar so angeordnet sind, daß sie im wesentlichen parallel zueinander sind und sich mit den Streifen von dem anderen Paar kreuzen und so dimensioniert sind, daß sie diese überlappen und magnetisch damit gekoppelt sind, wobei der Grad dieser Überlappung so ist, daß weniger als 25% der Länge jedes Streifens über die Seite eines kreuzenden Streifens von einem anderen Paar hinausragt, und die Streifen von einem ersten Paar dadurch Flußkollektoren bilden, die den Magnetfluß von Feldern, die im wesentlichen parallel zu den Streifen des zweiten Paares verlaufen, in die Streifen des zweiten Paares konzentrieren.
2. Etikett nach Anspruch 1, dadurch gekennzeichnet, daß alle diese Streifen im wesentlichen dieselben Abmessungen besitzen.
3. Etikett nach Anspruch 1, dadurch gekennzeichnet, daß alle diese Streifen im wesentlichen dieselbe Zusammensetzung besitzen.
4. Etikett nach Anspruch 1, ferner umfassend mindestens einen Abschnitt (22, 24, 26, 28, 30, 32, 34, 36; 48, 50, 52, 54; 66, 68, 70, 72) aus einem dauerhaft magnetisierbaren Material, der angrenzend an diese Streifen positioniert ist und magnetisch damit gekoppelt ist, so daß dann, wenn er derart magnetisiert ist, die von dem Etikett kommende erfaßbare Antwort geändert ist.
5. Etikett nach Anspruch 4, dadurch gekennzeichnet, daß ein Stück (66, 68, 70, 72) aus dauerhaft magnetisierbaren Material über den Kreuzungspunkten der Streifen positioniert ist.

15

20

25

30

35

Revendications

1. Dispositif marqueur destiné à une utilisation dans un système électronique de surveillance d'objets du type dans lequel un champ magnétique alternatif dans une zone d'interrogation produit des modifications de magnétisation détectables à distance dans le dispositif marqueur, caractérisé en ce que le dispositif marqueur comprend au moins deux paires (14 et 18 et 16 et 20; 40 et 42 et 44 et 46; 56 et 60 et 58 et 62) de bandes d'une matière magnétique d'une haute perméabilité et de faible force coercitive, les deux paires de bandes étant positionnées sensiblement dans le même plan, les bandes de chaque paire étant positionnées de manière à être sensiblement parallèles l'une à l'autre et coupant les bandes de l'autre paire et étant dimensionnées de manière à recouvrir et à être couplées magnétiquement avec celles-ci, l'étendue de ce recouvrement étant tel que moins de 25 % de la longueur de chaque bande s'étend au-delà du côté d'une bande d'intersection d'une autre paire, les bandes d'une première paire formant ainsi des collecteurs de flux pour concentrer le flux provenant de champs s'étendant sensiblement parallèlement aux bandes de la seconde paire dans les bandes de la seconde paire.
2. Dispositif marqueur suivant la revendication 1, caractérisé en ce que toutes les bandes ont sensiblement la même dimension.

40

45

50

55

3. Dispositif marqueur suivant la revendication 1, caractérisé en ce que toutes les bandes ont sensiblement la même composition.
- 5 4. Dispositif marqueur suivant la revendication 1, caractérisé en ce qu'il comprend en outre au moins une section (22, 24, 26, 28, 30, 32, 34, 36; 48, 50, 52, 54; 66, 68, 70, 72) d'une matière susceptible d'une magnétisation rémanente positionnée à proximité de chacune de ces bandes et couplée magnétiquement à celles-ci de telle sorte que, lorsque magnétisée de la sorte, la réponse détectable résultant du dispositif marqueur soit modifiée.
- 10 5. Dispositif marqueur suivant la revendication 4, caractérisé en ce qu'un morceau (66, 68, 70, 72) d'une matière susceptible d'une magnétisation permanente est positionnée sur les intersections des bandes susdites.

15

20

25

30

35

40

45

50

55

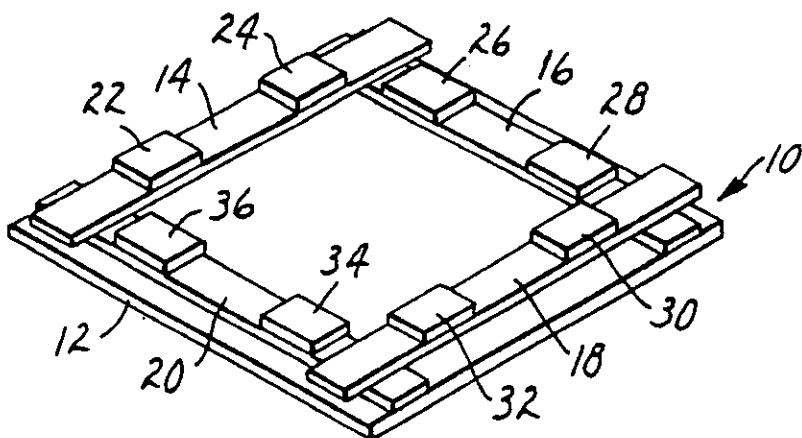

FIG. 1

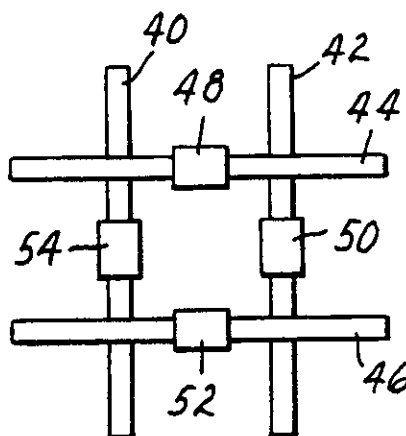

FIG. 2

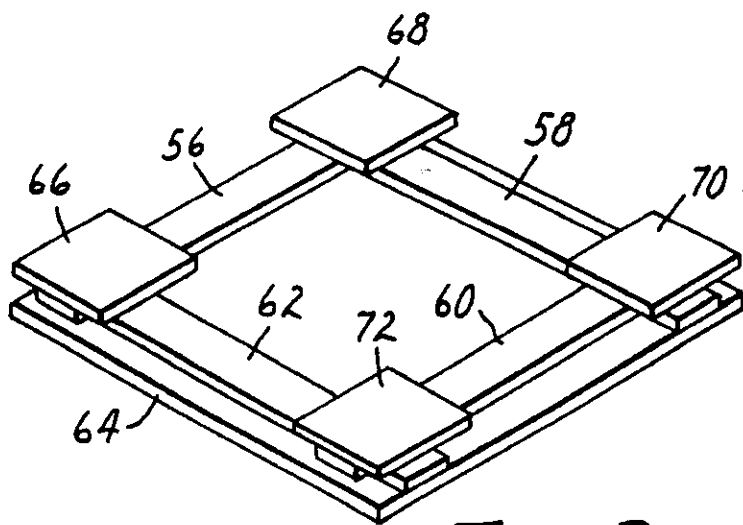

FIG. 3

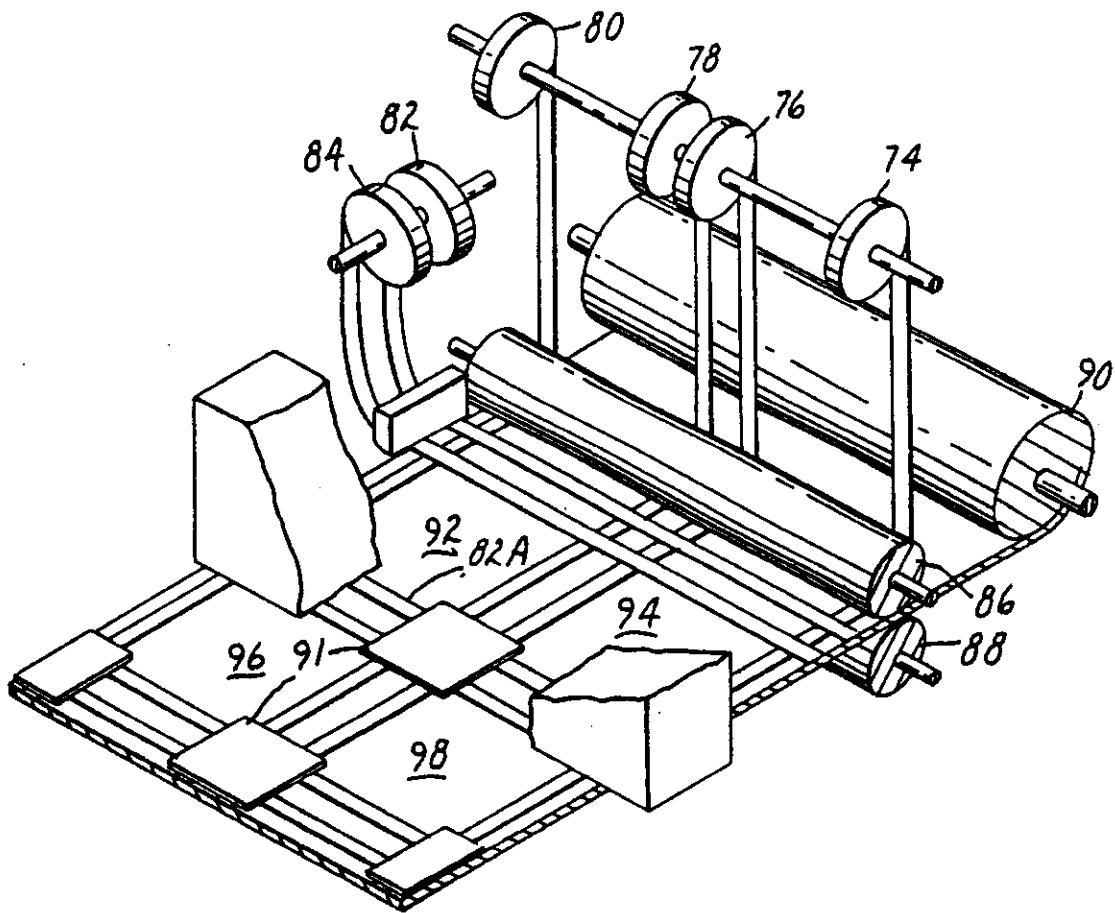

FIG. 4

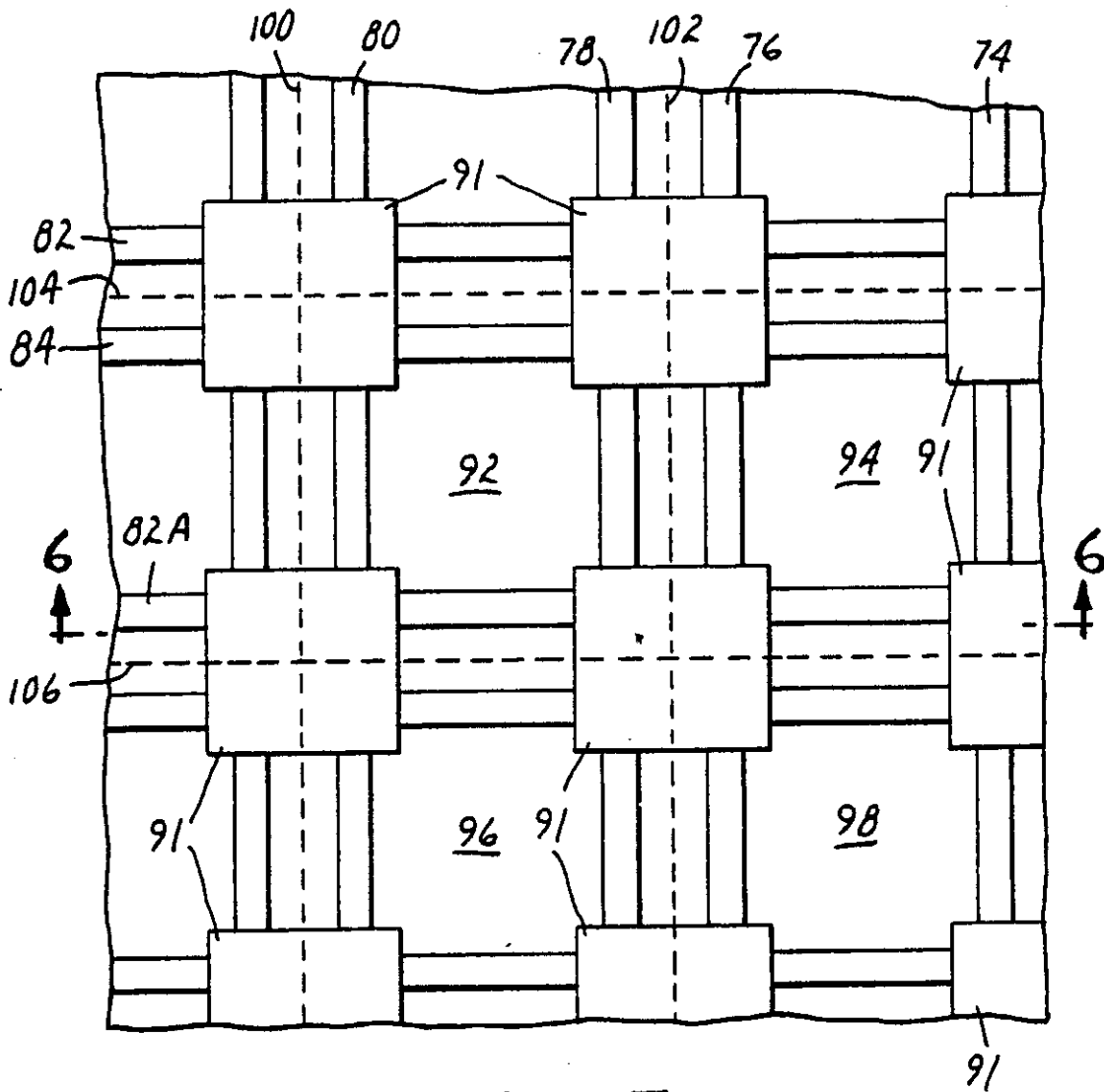

FIG. 5

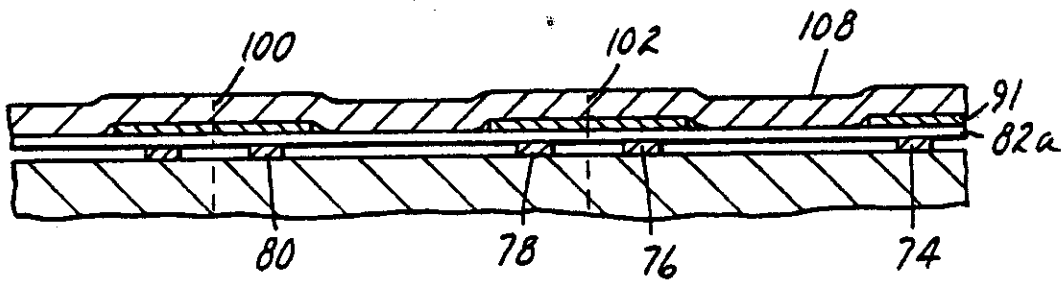

FIG. 6

REGISTER ENTRY FOR EP0319248

European Application No EP88311299.7 filing date 29.11.1988

Priority claimed:

30.11.1987 in United States of America - doc: 126749

Designated States BE CH DE ES FR GB IT LI NL SE

Title ECONOMIC, MULTI-DIRECTIONALLY RESPONSIVE MARKER FOR USE IN ELECTRONIC
ARTICLE SURVEILLANCE SYSTEMS.

Applicant/Proprietor

MINNESOTA MINING AND MANUFACTURING COMPANY, 3M Center, P.O. Box 33427, St.
Paul, Minnesota 55133-3427, United States of America [ADP No. 50012772006]

Inventor

CLYDE T. EISENBEIS, c/o Minnesota Mining and Manufacturing Company 2501
Hudson Road, P.O. Box 33427 St. Paul Minnesota 55133, United States of
America [ADP No. 56605280001]

Classified to

G08B

Address for Service

LANGNER PARRY, High Holborn House, 52-54 High Holborn, LONDON, WC1V 6RR,
United Kingdom [ADP No. 00001032001]

EPO Representative

IAIN CAMERON BAILLIE, c/o Ladas & Parry Isartorplatz 5, D-8000 München 2,
Federal Republic of Germany [ADP No. 50848357001]

Publication No EP0319248 dated 07.06.1989

Publication in English

Examination requested 17.09.1990

Patent Granted with effect from 23.06.1993 (Section 25(1)) with title
ECONOMIC, MULTI-DIRECTIONALLY RESPONSIVE MARKER FOR USE IN ELECTRONIC
ARTICLE SURVEILLANCE SYSTEMS.

18.06.1990 EPO: Search report published on 18.07.1990

Entry Type 25.11 Staff ID. Auth ID. EPT

24.05.1993 Notification from EPO of change of Applicant/Proprietor details
from

MINNESOTA MINING AND MANUFACTURING COMPANY, 3M Center, P.O. Box
33427, St. Paul, Minnesota 55133-3427, United States of America
[ADP No. 50012772006]

to

MINNESOTA MINING AND MANUFACTURING COMPANY, 3M Center, P.O. Box
33427, St. Paul, Minnesota 55133-3427, United States of America
[ADP No. 50012772006]

Entry Type 25.14 Staff ID. RD06 Auth ID. EPT

- 24.05.1993 Notification from EPO of change of EPO Representative details from
IAIN CAMERON BAILLIE, c/o Ladas & Parry Isartorplatz 5, D-8000
München 2, Federal Republic of Germany [ADP No. 50848357001]
to
IAIN CAMERON BAILLIE, c/o Ladas & Parry, Altheimer Eck 2, W-8000
München 2, Federal Republic of Germany [ADP No. 50848357001]
Entry Type 25.14 Staff ID. RD06 Auth ID. EPT
- 28.05.1993 LANGNER PARRY, High Holborn House, 52-54 High Holborn, LONDON, WC1V
6RR, United Kingdom [ADP No. 00001032001]
registered as address for service
Entry Type 8.11 Staff ID. ALC1 Auth ID. AA

**** END OF REGISTER ENTRY ****

OA80-01
EP

OPTICS - PATENTS

13/05/94 09:26:11
PAGE: 1

RENEWAL DETAILS

PUBLICATION NUMBER EP0319248

PROPRIETOR(S)

MINNESOTA MINING AND MANUFACTURING COMPANY, 3M Center, P.O. Box
33427, St. Paul, Minnesota 55133-3427, United States of America

DATE FILED 29.11.1988
DATE GRANTED 23.06.1993
DATE NEXT RENEWAL DUE 29.11.1994
DATE NOT IN FORCE
DATE OF LAST RENEWAL 28.10.1993
YEAR OF LAST RENEWAL 06
STATUS PATENT IN FORCE