

(No Model.)

J. STERN.  
HORSE DETACHER.

No. 455,241.

Patented June 30, 1891.

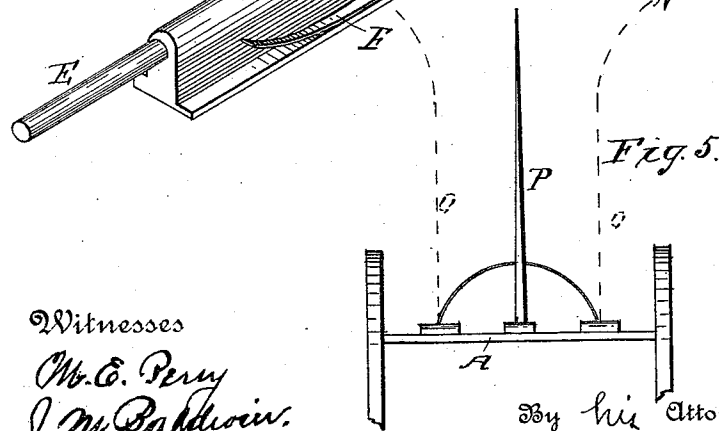
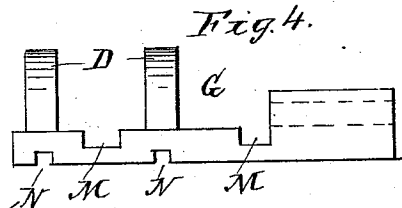
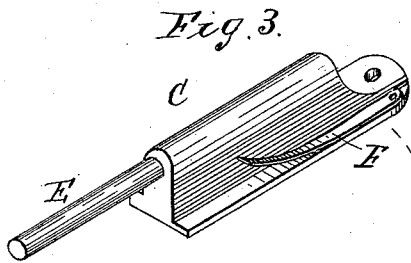
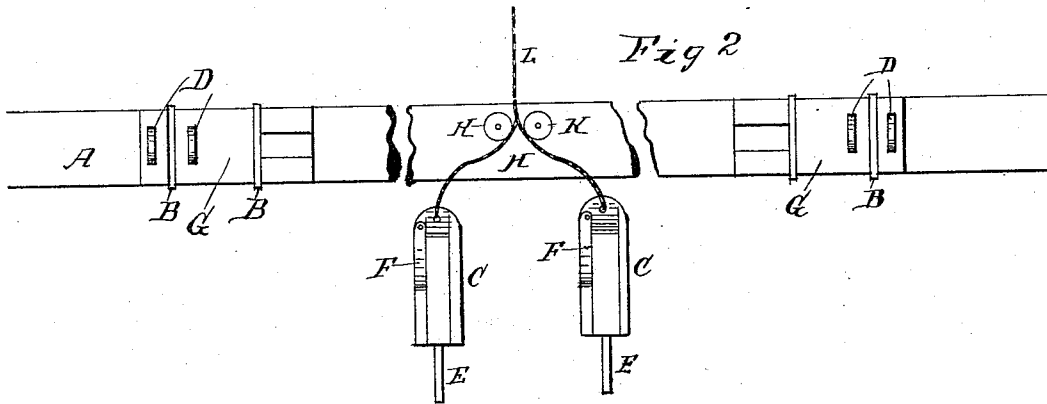
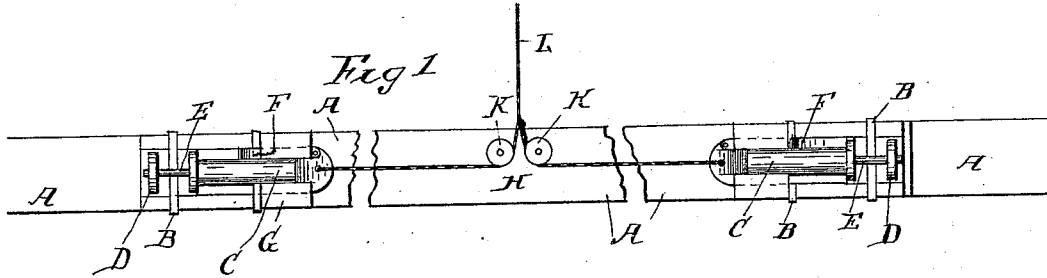

Witnesses  
Chas. E. Perry  
J. M. Baldwin.

Inventor  
Joseph Stern  
By his Attorney  
W. R. Stringfellow

# UNITED STATES PATENT OFFICE.

JOSEPH STERN, OF NEW ORLEANS, LOUISIANA.

## HORSE-DETACHER.

SPECIFICATION forming part of Letters Patent No. 455,241, dated June 30, 1891.

Application filed March 9, 1891. Serial No. 384,378. (No model.)

To all whom it may concern:

Be it known that I, JOSEPH STERN, a citizen of the United States, residing at New Orleans, in the parish of Orleans and State of Louisiana, have invented certain new and useful Improvements in a Shaft Detacher and Attacher; and I do declare the following to be a full, clear, and exact description of the invention, such as will enable others skilled in the art to which it appertains to make and use the same.

My invention relates to an improvement in a detacher and attacher for a vehicle shaft or pole, and its novelty will be fully understood from the following description and claim, when taken in connection with the annexed drawings; and the objects of my invention are to provide a device that will enable the shaft or pole of a buggy to be readily detached in case the animals harnessed to the vehicles should run or attempt to kick. I attain these objects by the mechanism illustrated in the accompanying drawings, in which—

Figure 1 is a top view of a front axle with my improved device in position. Fig. 2 is a similar view with the device displaced. Fig. 3 is an enlarged perspective view of the slide. Fig. 4 is an enlarged side elevation of the bed-plate, and Fig. 5 is a top view of a front axle with my device in position to operate the vehicle-pole or a pair of shafts.

Similar letters refer to similar parts throughout the several views.

In the drawings, A refers to a front axle. B are bands which hold bed-plate G to axle. C is a slide which rests on bed-plate G when device is in position as shown in Fig. 1, showing end of bed-plate. The slide is made of metal and has a projecting arm or rod E, which engages metal pieces D by entering the eye in said pieces. Said pieces D are inserted in bed-plate G through slots N and are held in position by their peculiar construction, the

flanges on D forming a brace under the bed-plate G, and M showing slots in G, in which the bands B rest when clasp the plates G to axle. Upon one side of the slide C, I place a spring, as shown by F, which holds slide in position to bed-plate G when inserted in end of bed-plate.

O represents a vehicle-shaft, and P a pole.

At a point shown by H, I place a box, in which there are two pulleys K, over which passes a small chain L, which extends upward, and by suitable means—say a ring on end of chain—is attached to dash-board of vehicle.

In attaching a pair of shafts or a pole to a vehicle the rod E performs the same functions as an ordinary thill-coupling and holds shaft or pole in position to axle, occupying position shown in Fig. 1. Should the animal, when attached to shaft, or a team hitched to a vehicle-pole, become unruly and attempt to run, by simply pulling upon the chain L the slide C is released from bed-plate G and occupies the position shown in Fig. 2 and enables shaft or pole to be detached from vehicle and prevents occupants of same from being injured.

Having described my invention, what I claim, and desire to secure by Letters Patent, is—

In a horse-detacher, the combination of the plate G, having grooves or slots, and the bands B, whereby the plate is attached to the axle of a vehicle, with the slide C, having the projection E, and the spring F, secured to the slide, so as to connect the said plate and slide, substantially as shown and described.

In testimony whereof I affix my signature in presence of two witnesses.

JOSEPH STERN.

Witnesses:

ISAAC L. HASPE,  
PERCY D. PARKS.