

July 20, 1926.

E. EHRHARDT

1,593,164

APPARATUS FOR THE ELECTRIC TRANSMISSION OF SIGNS

Filed August 5, 1924

2 Sheets-Sheet 1

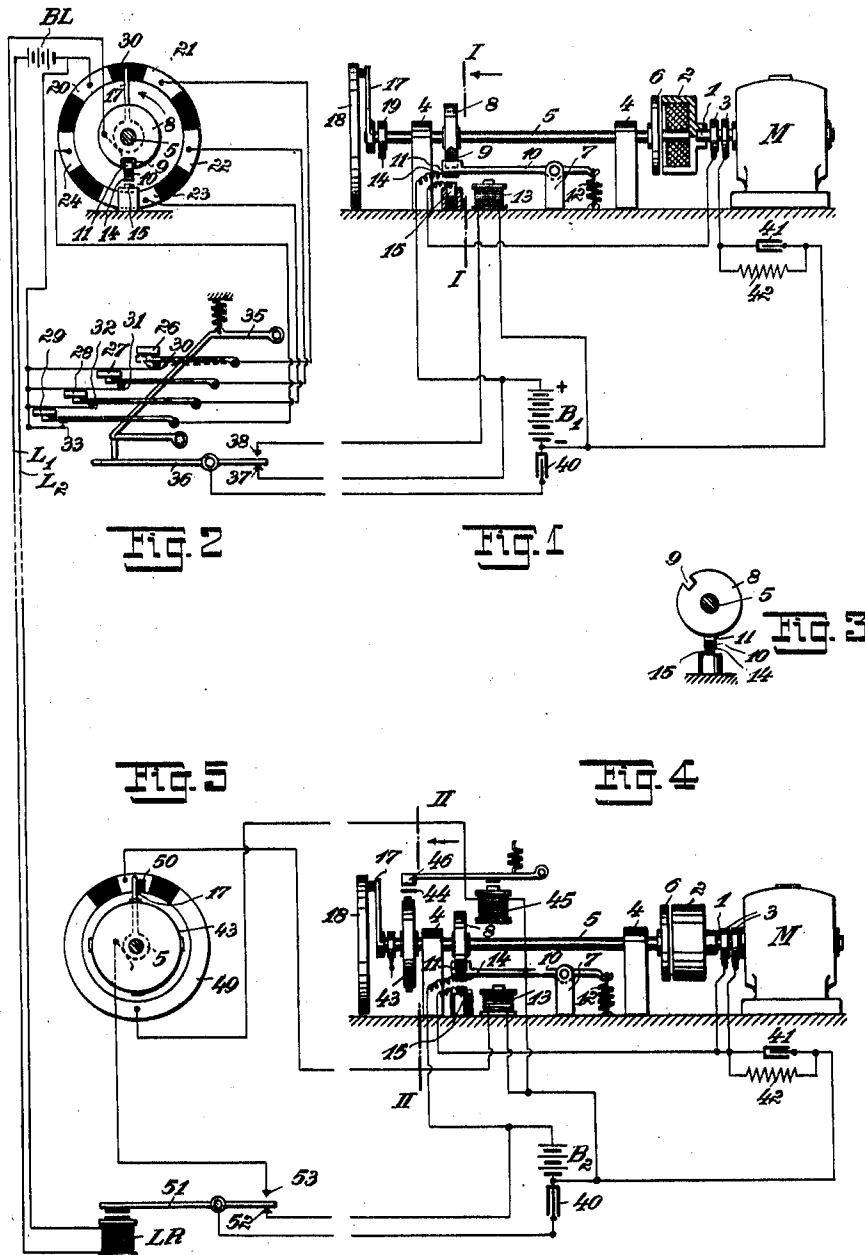

Inventor
Ewin Ehrhardt
by Knight Bros
attorneys

July 20, 1926.

1,593,164

E. EHRHARDT

APPARATUS FOR THE ELECTRIC TRANSMISSION OF SIGNS

Filed August 5, 1924

2 Sheets-Sheet 2

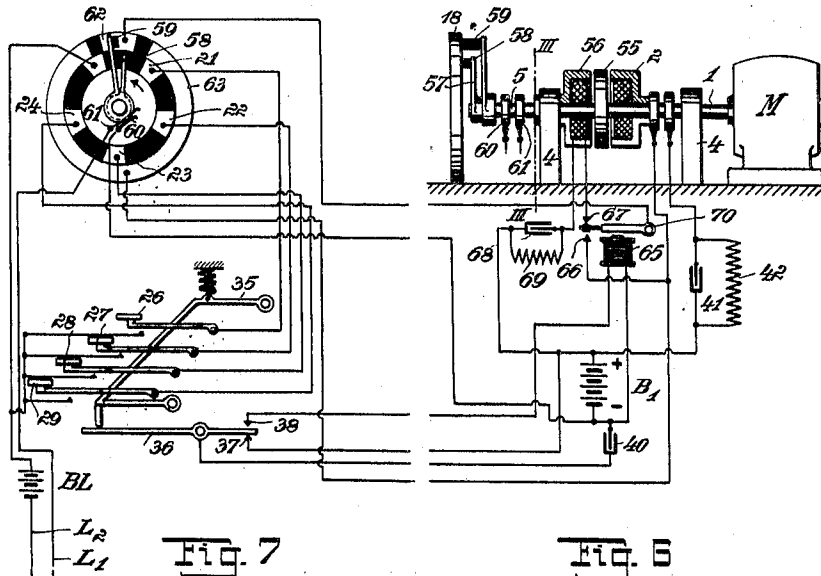

Fig. 7

Fig. 6

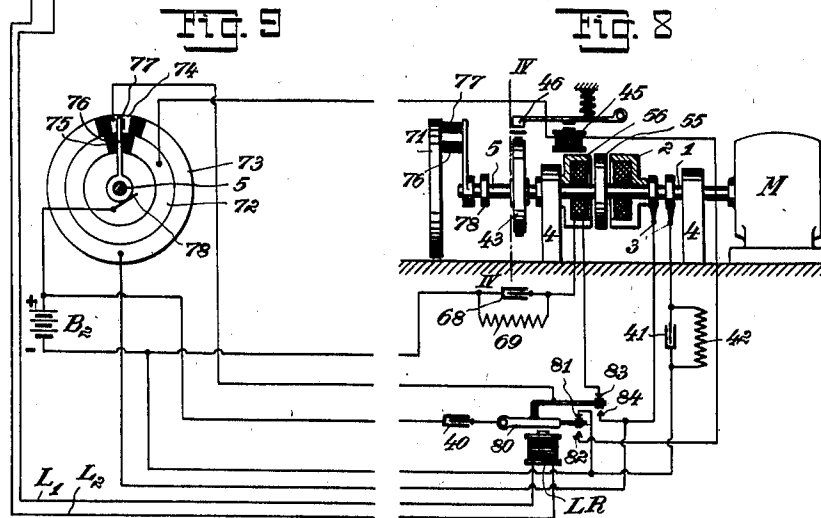

Fig. 9

Fig. 8

Inventor
Erwin Ehrhardt
by Knight Bros
Attorneys

UNITED STATES PATENT OFFICE.

ERWIN EHRHARDT, OF HERMSDORF, NEAR BERLIN, GERMANY, ASSIGNOR TO SIEMENS & HALSKE, AKTIENGESELLSCHAFT, OF SIEMENSSTADT, NEAR BERLIN, GERMANY, A CORPORATION OF GERMANY.

APPARATUS FOR THE ELECTRIC TRANSMISSION OF SIGNS.

Application filed August 5, 1924, Serial No. 730,210, and in Germany August 8, 1923.

My invention relates to improvements in apparatus for the electric transmission of signs and is particularly suitable for type-printing telegraphs in which the imprint of the type at the receiver is effected by a type wheel rotating synchronously with the moving parts of the transmitter. In carrying out my invention the transmission systems known for the purpose are made use of and my invention consists essentially in the feature that by means of an electro-magnetic coupling rendered operative by the giving of a sign at the transmitter the moving parts of the transmitter and the receiver are each coupled with continuously rotating driving shafts and are each arrested by a locking device when the starting position is reached, which locking device is rendered inoperative simultaneously with the switching in of the coupling magnets and operative with the cutting out of said magnet, the reproduction of the sign transmitted and more particularly the imprint of the type taking place instantaneously at the moving part of the receiver when the angular position of the type-wheel corresponding with the sign to be printed has been reached.

In the drawings affixed to this specification and forming part thereof two embodiments of my invention are illustrated by way of example.

In the drawing:—

Fig. 1 is a sectional side-elevation of the transmitter of a type-printing telegraph with mechanical locking device,

Fig. 2 is a section along line I—I of Fig. 1, and shows the distributing disc in front elevation,

Fig. 3 shows the locking disc in the released position,

Fig. 4 shows the receiver of this telegraph system in side elevation,

Fig. 5 is a section along line II—II of Fig. 4,

Fig. 6 is a sectional side-elevation of the transmitter of a type-printing telegraph with an electro-magnet locking device,

Fig. 7 is a section along line III—III of Fig. 6,

Fig. 8 shows the receiver of this system in side elevation and

Fig. 9 is a section along line IV—IV of Fig. 8.

Similar parts are indicated by similar letters or numbers of reference throughout all the figures of the drawings.

Referring to Figs. 1 to 3, M is the driving motor which during the operation of the system continuously rotates the driving shaft 1. Upon said driving shaft is mounted a pot-shaped magnet 2 which receives its exciting current by means of sliding brushes 3. The shaft 5 to be driven is journaled in bearings 4 and at its front end is mounted an iron coupling disc 6 in such a manner that it firmly adheres to the pot-shaped magnet 2 when said magnet is excited. This disc 6 may either be adapted to slide upon the shaft 5 axially while rotating with it or the entire shaft with the fixed half-coupling may have slight axial play in its bearings in order to enable the coupling operations to take place. Upon the shaft 5 is mounted a disc 8, also shown in side-elevation in Figs. 2 and 3. Said disc is provided with a recess or notch 9 which in the initial position of the transmitter is engaged by a lever 10 with a nose or projection 11. The lever 10 is fulcrumed in a bearing or standard 7 and is controlled by a spring 12 having the tendency to force it against the disc 8. The lever forms the armature of a magnet 13 and carries an insulated contact 14 which when the lever is attracted by its magnets cooperates with a back contact 15. The contacts 14 and 15 also remain closed as long as the nose 11 of the lever 10 rests upon the circumference of the disc 8.

Upon the rear end of the shaft 5 is mounted a brush arm 17 which rotates above a distribution disc 18. The brush is connected with one conductor L_1 of the telegraph line by means of a slip-ring. The other conductor L_2 of this line contains the line or main battery BL and is connected with one contact segment 20 of the distributing disc 18. With the other segments 21, 22, 23, 24 of the disc are connected the keys 26, 27, 28, 29. In the starting position of the apparatus the brush arm 17 is upon an insulated portion 30 of the distribution disc 30.

For the sake of simplifying the illustrations four type keys 26 to 29 only are illustrated. Their number as well as the number of the corresponding segments 21 to 24 upon the distributing disc 18 corresponds in the actual construction of the apparatus with all the letters of the alphabet and signs. The key board is also only diagrammatically illustrated in other respects as it is perfectly well known and is only described with a view of more easily explaining the complete type transmitting system. To the various keys belong contacts 30, 31, 32 and 33 which are closed when the keys are depressed. All the keys control a contact rail 35 which during the depression of any key moves a lever 36 change over the contacts 37 and 38.

The manner of operation of this system is as follows:

The motor M continuously drives the pot-shaped coupling magnet 2. When a key is depressed, for instance the key 26, the lever 36 is changed over and its tail and moves from the contact 37 to the contact 38. The release magnet 13 now receives the discharge current rush of a condenser 40 which in the position of rest of the lever 36 was charged by the local battery B_1 by way of the contact 37. The magnet 13 attracts the lever 10 so that on the one hand the nose 11 is withdrawn from the notch of the locking disc 8 and on the other hand the contacts 14, 15 are closed. The shaft 5 is thus released and the pot-shaped magnet 2 receives exciting current from the battery B_1 . This current is in the first moment the charging current of a condenser 41 and corresponding therewith very strong. A considerably weaker holding current flows across a resistance 42 connected in parallel with the condenser 41. As soon as the shaft 5 has performed a complete revolution the nose of the lever 10 again engages the notch 9 in the locking disc 8 whereby the exciter circuit of the coupling magnet 2 is interrupted and the shaft 5 is arrested. The condenser 41 then discharges across its resistance 42 connected in parallel with it.

During the rotation of the shaft 5 the brush arm 17 has first passed from the insulating segment 30 to the segment 20 and a current surge is sent from the line battery BL across the two line conductors L_1 , L_2 by way of the segment 20 and the slip-ring 19 which effects the release of the receiver. A further surge or rush of current takes place as soon as the brush arm 17 sweeps the segment 21 connected with the depressed key 26 which surge effects the reproduction of the corresponding letter or sign.

Referring to Figs. 4 and 5, it will be seen that the receiver consists essentially of a device or mechanism very similar to the trans-

mitter and from which it only differs in so far as a type wheel 43 is mounted on the driven shaft 5 across which wheel a paper tape 44 is passed. The imprint of the type on said tape is effected by the printing magnet 45 knocking its hammer 46 on the back of the tape and against the type on the wheel. The distributing disc again shown separately in side elevation in Fig. 5 consists of a ring 49 and a contact segment 50 insulated upon it.

The manner of operation of the receiver is the following: during the first current rush in the line L_1 , L_2 passing over the segment 20 of the transmitter the line relay LR is excited for a short period and by attracting its contact lever 51 opens the contact 52 and closes the contact 33. In correspondence herewith the condenser 40 which had been charged from the battery B_2 while the contact 52 was closed now discharges over the distributing switch 17, the segment 50 and the releaser magnet 13. This magnet releases the shaft 5 exactly as in the case of the transmitter and closes the contacts 14 and 15 so that the coupling magnet 2 receives current and couples the shaft 5 with the motor shaft 1. The brush arm 17 then passes on to the distributing ring 49 connected with the printing magnet 45 and in the moment in which the second sign surge of the transmitter takes place (in the case mentioned across the segment 21), the line relay LR is again excited and the discharge current rush of the condenser 40 passes across the lever 51, contact 53, brush arm 17, ring 49 and the printing magnet 45. The latter knocks the hammer 45 against the paper tape 44 and the type wheel 43 so that the sign given at the transmitter is imprinted on the tape. After a complete revolution of the shaft 5 said shaft is arrested at the locking disc 8 by means of the locking lever 10, 11 in exactly the same manner as at the transmitter.

Referring to Fig. 6 which shows a type-printing telegraph apparatus in sectional side-elevation in which the locking or arresting mechanism is operated electro-magnetically and Fig. 7 which is a transverse section along the line III—III of Fig. 6 and shows the distributing disc in front elevation, M is again the motor which continuously drives the shaft 1 on which the pot-shaped coupling magnet 2 is mounted. The armature disc 55 mounted on the shaft 5 is effected on the one hand by the coupling magnet 2 and on the other hand by the stationary brake magnet 56. The disc armature 55 is again adapted to slide axially upon the shaft 5 or the shaft 5 is axially movable to such an extent that the armature 55 can come in contact either with the pot-shaped magnet 8 or the brake magnet 56. Upon the shaft 5 are mounted brush arms

57 which carry insulated brushes 58, 59 of which the brush 58 is connected by means of a sliding brush 60 with one pole of the local battery B_1 and the brush 59 by means of a sliding brush 61 with one branch L_1 of the line. The distributing disc 18 contains two concentric contact rings. The outer comprises a contact segment 62 in the initial position of the brush and an annular contact 63 connected with the terminal of the coupling magnet 2. The inner contact ring comprises a release contact segment 20 next to the insulated initial position of the corresponding contact brush 58. Its further sign contacts 21 to 24 are connected with the printing keys 26 to 29 the construction of which corresponds with that shown in Figs. 1 and 2. A modification as compared with the first example consists in the feature that instead of the release magnet a change-over magnet 65 is provided here across the contacts 66 or 67 of which either the coupling magnet 2 or the brake magnet 56 is excited.

The manner of operation of the transmitting mechanism is the following: in the inoperative position the brake magnet 56 receives current from the battery B_1 , sliding brush 60, contact brush 59, segment 62, back contact 67 of the magnet 65 and a resistance 69 connected in parallel with the condenser 68. As soon as a key, for instance the key 28 is depressed the key rail 35 changes the key lever 36 over against the contact 38 so that the discharge current rush of the condenser 40, which had been charged in the inoperative position of the mechanism across the contact 37, flows by way of the contact 38 through the coils of a magnet 65. This magnet sharply attracts its armature 70 and thus interrupts the exciter circuit of the brake magnet 56 at the contact 67. Simultaneously it closes at the contact 66 the circuit of the coupling magnet 2 which includes the distributing brush 59, the back contact segment 62, armature 70, contact 66, exciter coil 2, condenser 41 and the battery B_1 so that first a strong charging current surge is produced at the condenser which is later on followed by a weaker holding current across the resistance 42. The shaft 5 rotates and the contact brush 59 passes on to the ring contact 63 so that the holding circuit for the coupling magnet remains closed. The brush 58 first passes on to the release segment 20 so that a current surge takes place from the line battery BL across the line conductors L_1, L_2 as in the first described example. Later on a current surge is despatched for imprinting the sign across the contact segment 23 in the manner already described, for instance by depressing the key 28. When the shaft 5 has completed a revolution the brush arm 59 passes over the insulation on to the segment 62 whereby the

holding circuit for the coupling magnet 2 is interrupted and on the other hand the brake magnet 56 is again made operative which arrests the driven parts in the initial position.

The receiver cooperating with the just described transmitter is illustrated in the Figures 8 and 9. Referring to these figures the type wheel 43 is mounted on the shaft 5 similar to the mechanism illustrated in Fig. 4. This type wheel cooperates with the hammer 46 actuated by the printing magnet 45. The distributor 71 is shown in front elevation in Fig. 9 which is a cross section along the line IV—IV of Fig. 8. It consists of two ring contacts 72, 73 the former of which is provided with an insulating segment 75 in the starting position while the latter ring 73 is furnished with a conducting part 74 for this position. The two brushes 76, 77 are connected with each other and by means of a sliding brush 78 with the local battery B_2 . This circuit is controlled by the line relay LR the armature 80 of which operates two pairs of contacts 81, 82 and 83, 84.

The manner of operation of this mechanism is as follows: in the operative position the brake magnet 56 receives the current of the battery B_2 by means of the sliding brush 78, the contact brush 77, the contact segment 74, the line relay contact 83 and the resistance 69 which is connected in parallel to the condenser 68. In the inoperative position the circuit of the condenser 40 is closed by means of the contact 81 of the line relay LR so that the condenser is charged by the battery B_2 . As soon as the release current surge passes across the lines L_1, L_2 and the line relay attracts its armature 80 a changing over from the contact 83 to the contact 84 takes place and the coupling magnet 2 receives the charging current surge of the condenser 41 across the contacts 84 and the segment 74. Simultaneously the brake magnet 55 is cut out so that the receiver shaft 5 begins to revolve. The brush 77 then passes on to the ring contact 73 and the holding circuit of the coupling magnet 2 across the resistance 42 is closed. The changing over at the contacts 81, 82 taking place simultaneously with the first excitation of the line relay has no effect because the brush 72 controlling the printing magnet 45 still stands on the insulation 75. On arrival of the sign giving current surge the line relay LR is excited again. Now the discharge current surge of the condenser 40 passes over the contact 82, the printing magnet 45, the ring contact 72 and the brushes 76 and 78 so that the imprint of the type or the like takes place at the right moment. The changing over at the relay contacts 83, 84 taking place during the printing current surge remains without effect. Only when the contact brushes 75, 77 reach the initial position the

exciter circuit of the coupling magnet 2 is interrupted and the circuit of the brake magnet 56 closed so that the moving parts come to rest again in the initial position.

5 It will be readily understood that I do not limit myself to the exact details of construction of the mechanisms illustrated by way of example and that these may be modified within the ambit of my claims without
10 departing from the spirit of my invention.

What I claim as my invention and desire to secure by Letters Patent is:—

1. In apparatus for the electric transmission of signs in combination, continuously
15 revolving driving shafts at the transmitter and at the receiver station, mechanism for transmitting signs at the transmitter station, mechanism for receiving and reproducing
20 said signs at the receiver station and an electro-magnetic coupling for connecting said transmitting and receiving mechanisms with said continuously revolving shafts, and means for releasing said coupling after
a complete revolution.

2. In apparatus for the electric transmission of signs in combination, continuously
25 revolving driving shafts at the transmitter and at the receiver station, mechanism for transmitting signs at the transmitter station, mechanism for receiving and reproducing
30 said signs at the receiver station, an electro-magnetic coupling for connecting said transmitting and receiving mechanisms with said continuously revolving shafts, and means for
35 automatically releasing said coupling after a complete revolution of said transmitting and receiving mechanisms.

3. In apparatus for the electric transmission of signs in combination, continuously
40 revolving driving shafts at the transmitter and receiver stations, shafts adapted to be driven by said driving shafts, locking discs upon said driven shafts provided with
45 notches, locking levers adapted to engage said notches, release magnets adapted to control said levers, electro-magnetic couplings adapted to connect said driving shafts with
50 said driven shafts, said locking levers being adapted to keep the exciter circuit of said coupling closed when sliding upon the circumference of said locking disc and to open
it when engaging the notch in said locking disc.

4. In apparatus for the electric transmission of signs in combination, continuously
55 revolving driving shafts at the transmitter and at the receiver stations, mechanism for transmitting signs at the transmitter station comprising a driven shaft, mechanism for
60 receiving and reproducing said signs at the receiving station comprising a driven shaft, an electro-magnetic coupling for connecting said transmitting and said receiving mechanism with said continuously revolving shafts,
65 a brake magnet mounted upon said driven

shaft at the transmitter and receiver station and a change-over magnet at each of said stations adapted to lead the exciter current either over said brake magnet or said coupling magnet.

5. In apparatus for the electric transmission of signs in combination, continuously
70 revolving driving shafts at the transmitter and at the receiver station, mechanism for transmitting signs at the transmitter station comprising a driven shaft, mechanism for receiving and reproducing said signs at
75 the receiver station comprising a driven shaft, electro-magnetic couplings for connecting said transmitting and said receiving mechanism with said continuously revolving shafts, additional current sources for energizing
80 said couplings, and means for controlling the currents from said sources to increase the intensity of the energizing currents when the energizing circuit is first closed and to subsequently decrease the intensity
85 during the remainder of the energization.

6. In apparatus for the electric transmission of signs in combination, continuously
90 revolving driving shafts at the transmitter and at the receiver station, mechanism for transmitting signs at the transmitter station comprising a driven shaft, mechanism for
95 receiving and reproducing said signs at the receiver station comprising a driven shaft, electro-magnetic couplings for connecting said transmitting and said receiving mechanism with said continuously revolving shafts,
100 additional current sources for energizing said couplings, a brake magnet mounted upon said driven shaft at the transmitter and receiver station and a change-over magnet at
105 each of said stations adapted to lead the exciter current either over said brake or said coupling magnet, and means for controlling the current from said additional sources to increase the intensity of the energizing currents
110 when the energizing circuit is first closed and to subsequently decrease the intensity during the remainder of the energization.

7. In apparatus for the electric transmission of signs in combination, continuously
115 revolving driving shafts at the transmitter and at the receiver station, mechanism for transmitting signs at the transmitter station comprising a driven shaft, mechanism for receiving and reproducing said signs at the
120 receiver station comprising a driven shaft, electro-magnetic couplings for connecting said transmitting and said receiving mechanism with said continuously revolving shafts, a current source and a circuit for each coupling,
125 a condenser in said circuit and a resistance bridging said condenser, the starting excitation of the magnets directly controlling the driven parts being effected by the charging current for said condenser and the
130

current for the permanent excitation being conducted over the resistance bridging said condenser.

8. In apparatus for the electric transmission of signs in combination, continuously revolving driving shafts at the transmitter and at the receiver station, mechanism for transmitting signs at the transmitter station comprising a driven shaft, mechanism for receiving and reproducing said signs at the receiving station comprising a driven shaft, electro-magnetic couplings for connecting said transmitting and said receiving mechanism with said continuously revolving shafts, a current source and a circuit for each cou-

pling, a brake magnet mounted upon said driven shaft at the transmitter and receiver station and a change-over magnet at each of said stations adapted to lead the exciter current either over said brake magnet or said coupling magnet, a condenser in circuit with each source and a resistance bridging said condenser, the starting excitation of the magnet directly controlling the driven parts being effected by the charging of said condenser current and the current for the permanent excitation being conducted over the resistance bridging said condenser.

In testimony whereof I affix my signature.
ERWIN EHRHARDT.