



(86) Date de dépôt PCT/PCT Filing Date: 2012/04/13
 (87) Date publication PCT/PCT Publication Date: 2012/10/18
 (85) Entrée phase nationale/National Entry: 2014/10/14
 (86) N° demande PCT/PCT Application No.: US 2012/033442
 (87) N° publication PCT/PCT Publication No.: 2012/142360
 (30) Priorité/Priority: 2011/04/15 (US13/088,243)

(51) Cl.Int./Int.Cl. *A61B 17/132* (2006.01),
A61B 17/135 (2006.01), *A61B 5/022* (2006.01),
A61H 9/00 (2006.01)

(71) Demandeur/Applicant:
 CELLAEGIS DEVICES INC., CA

(72) Inventeurs/Inventors:
 GANSKE, ROCKY, CA;
 GIL, LAHAV, CA;
 SHEPPERDLEY, ADAM, CA;
 CRACAUER, RAYMOND, US;
 ROYBLAT, IGAL, CA;
 CHRISTENSEN, KRISTOPHER THOMAS, CA;

(74) Agent: SMART & BIGGAR

(54) Titre : SYSTEME PERMETTANT D'EFFECTUER UN CONDITIONNEMENT ISCHEMIQUE A DISTANCE
 (54) Title: SYSTEM FOR PERFORMING REMOTE ISCHEMIC CONDITIONING

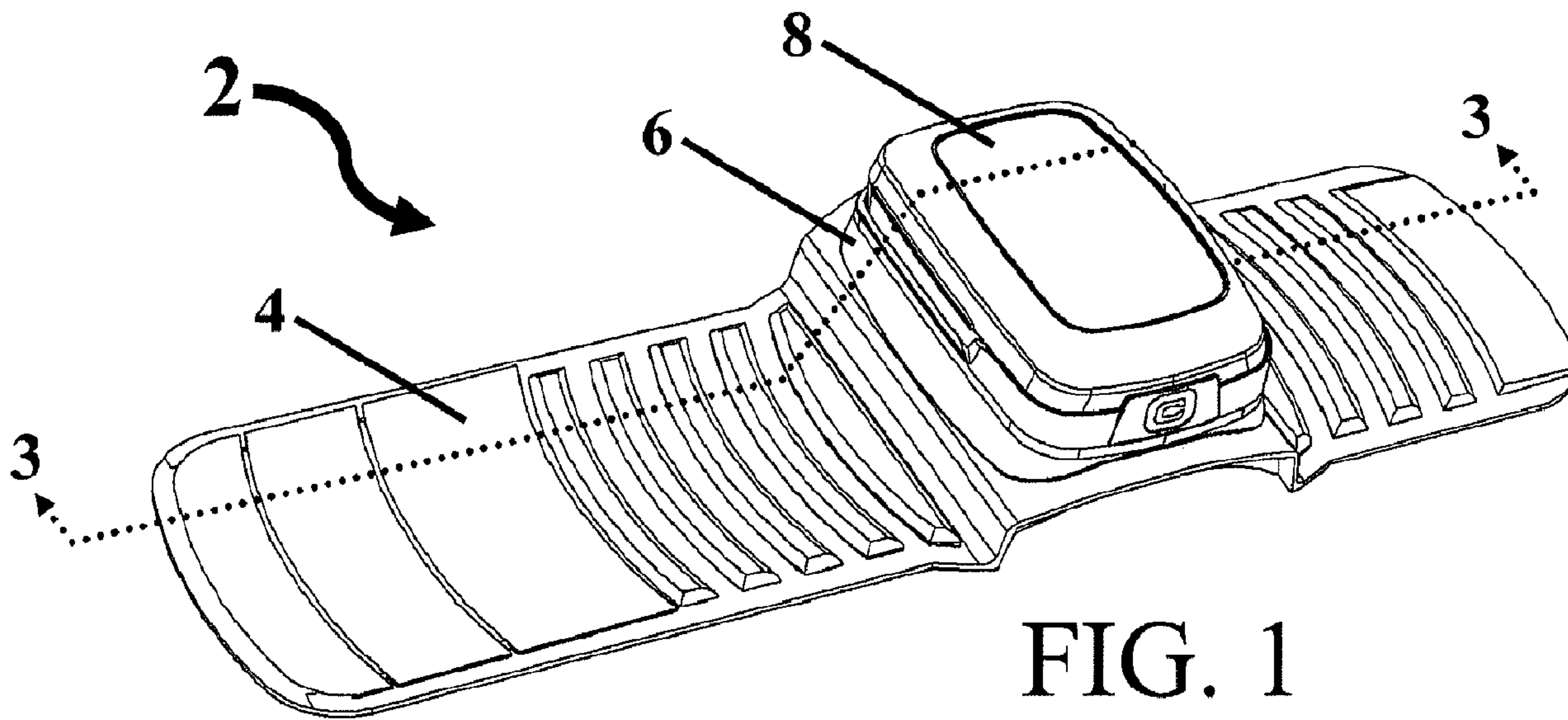

(57) Abrégé/Abstract:

A system (2) for performing remote ischemic conditioning includes an inflatable cuff (4) configured to encircle a limb of a subject and a controller (8) removably attached to the cuff. The controller includes a pump (62); a manifold (64) in fluid communication with the pump; a connector in fluid communication with the manifold and in removable fluid communication with the inflatable cuff; a pressure sensor; and a control circuit configured to implement a remote ischemic conditioning treatment protocol.

(72) Inventeurs(suite)/Inventors(continued): GADZIC, RADE, CA; CALDARONE, CHRISTOPHER, CA;
REDINGTON, ANDREW, CA

(12) INTERNATIONAL APPLICATION PUBLISHED UNDER THE PATENT COOPERATION TREATY (PCT)

(19) World Intellectual Property
Organization
International Bureau(43) International Publication Date
18 October 2012 (18.10.2012)(10) International Publication Number
WO 2012/142360 A3

- (51) **International Patent Classification:**
A61B 17/132 (2006.01) **A61B 5/022** (2006.01)
A61B 17/135 (2006.01) **A61H 9/00** (2006.01)
- (21) **International Application Number:**
PCT/US2012/033442
- (22) **International Filing Date:**
13 April 2012 (13.04.2012)
- (25) **Filing Language:** English
- (26) **Publication Language:** English
- (30) **Priority Data:**
13/088,243 15 April 2011 (15.04.2011) US
- (71) **Applicant (for all designated States except US):** **CEL-LAEGIS DEVICES INC.** [CA/CA]; 139 Mulock Avenue, 1st Floor, Toronto, Ontario M6N 1G9 (CA).
- (72) **Inventors; and**
- (75) **Inventors/Applicants (for US only):** **GANSKE, Rocky** [US/CA]; 3360 Petrie Way, Oakville, Ontario L6L 6V8 (CA). **GIL, Lahav** [CA/CA]; 5 Adrian Ave, Unit 110, Toronto, Ontario M6N 5G4 (CA). **SHEPPERDLEY, Adam** [CA/CA]; 5-151 Brunswick Ave., Toronto, Ontario M5S 2M3 (CA). **CRACAUER, Raymond** [US/US]; 55 League Trail, Beulah, CO 81023 (US). **ROYBLAT, Igal** [CA/CA]; 25 Owl Ridge Dr., Richmond Hill, Ontario L4S 1P7 (CA). **CHRISTENSEN, Kristopher, Thomas** [CA/CA]; 2243 Constance Drive, Oakville, Ontario L6J 5L8 (CA). **GADZIC, Rade** [CA/CA]; 240-179 Bleecker Street, Toronto, Ontario M4X 1L9 (CA). **CALDARONE, Christopher** [US/CA]; 96 Highland Avenue, Toronto, Ontario M4W 2A6 (CA). **REDINGTON, Andrew** [GB/CA]; 44 Warren Road, Toronto, Ontario M4V 2R5 (CA).
- (74) **Agent:** **GREEN, Lawrence, M.**; Wolf, Greenfield & Sacks, P.C., 600 Atlantic Avenue, Boston, MA 02210-2206 (US).
- (81) **Designated States (unless otherwise indicated, for every kind of national protection available):** AE, AG, AL, AM, AO, AT, AU, AZ, BA, BB, BG, BH, BR, BW, BY, BZ, CA, CH, CL, CN, CO, CR, CU, CZ, DE, DK, DM, DO, DZ, EC, EE, EG, ES, FI, GB, GD, GE, GH, GM, GT, HN, HR, HU, ID, IL, IN, IS, JP, KE, KG, KM, KN, KP, KR, KZ, LA, LC, LK, LR, LS, LT, LU, LY, MA, MD, ME, MG, MK, MN, MW, MX, MY, MZ, NA, NG, NI, NO, NZ, OM, PE, PG, PH, PL, PT, QA, RO, RS, RU, RW, SC, SD, SE, SG, SK, SL, SM, ST, SV, SY, TH, TJ, TM, TN, TR, TT, TZ, UA, UG, US, UZ, VC, VN, ZA, ZM, ZW.
- (84) **Designated States (unless otherwise indicated, for every kind of regional protection available):** ARIPO (BW, GH, GM, KE, LR, LS, MW, MZ, NA, RW, SD, SL, SZ, TZ, UG, ZM, ZW), Eurasian (AM, AZ, BY, KG, KZ, MD, RU, TJ, TM), European (AL, AT, BE, BG, CH, CY, CZ, DE, DK, EE, ES, FI, FR, GB, GR, HR, HU, IE, IS, IT, LT, LU, LV, MC, MK, MT, NL, NO, PL, PT, RO, RS, SE, SI, SK, SM, TR), OAPI (BF, BJ, CF, CG, CI, CM, GA, GN, GQ, GW, ML, MR, NE, SN, TD, TG).
- Published:**
- with international search report (Art. 21(3))
 - before the expiration of the time limit for amending the claims and to be republished in the event of receipt of amendments (Rule 48.2(h))
- (88) **Date of publication of the international search report:**
31 January 2013

(54) **Title:** SYSTEM FOR PERFORMING REMOTE ISCHEMIC CONDITIONING

FIG. 1

(57) **Abstract:** A system (2) for performing remote ischemic conditioning includes an inflatable cuff (4) configured to encircle a limb of a subject and a controller (8) removably attached to the cuff. The controller includes a pump (62); a manifold (64) in fluid communication with the pump; a connector in fluid communication with the manifold and in removable fluid communication with the inflatable cuff; a pressure sensor; and a control circuit configured to implement a remote ischemic conditioning treatment protocol.

SYSTEM FOR PERFORMING REMOTE ISCHEMIC CONDITIONING

5

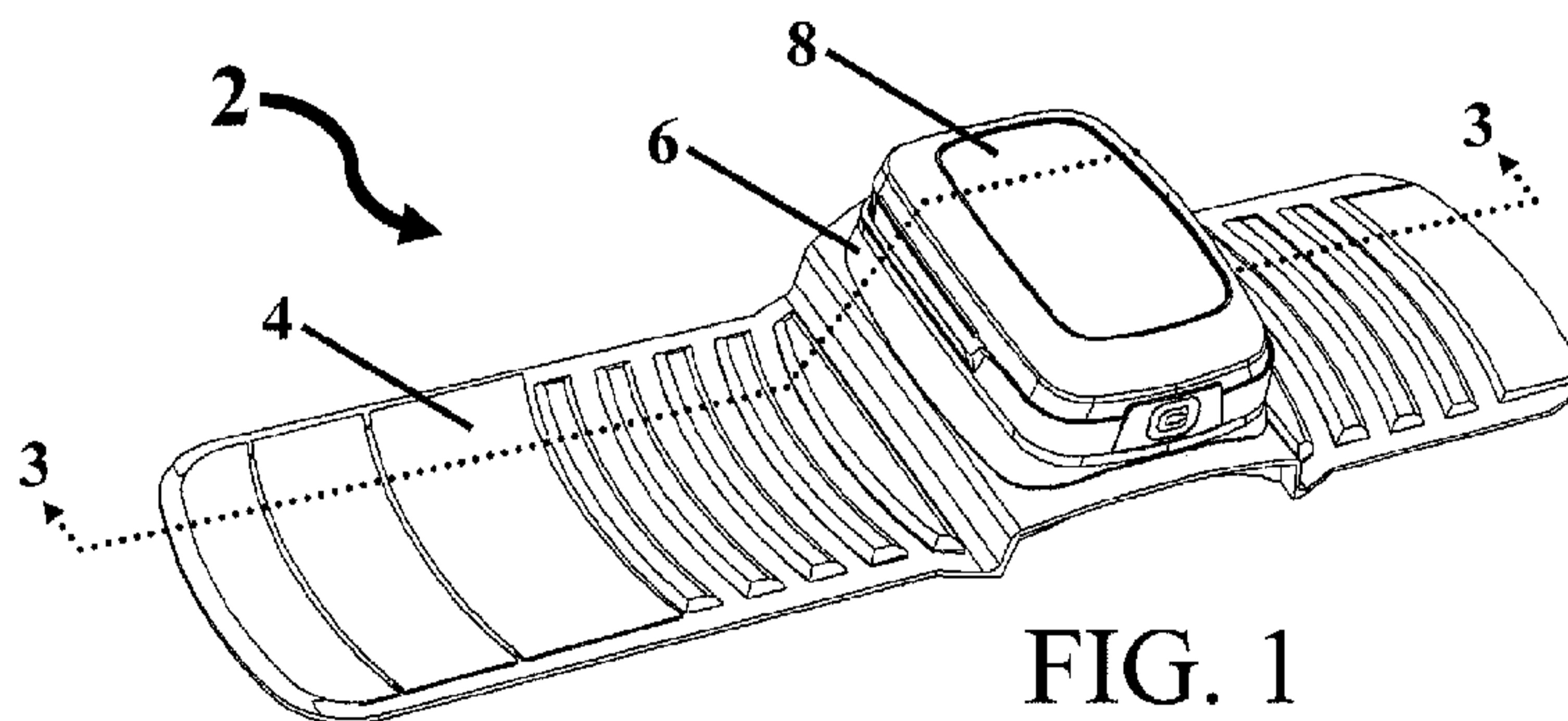
FIELD

This invention relates generally to systems for performing remote ischemic conditioning, and more particularly, to systems for performing remote ischemic conditioning incorporating a removable controller.

10

BACKGROUND

Ischemic diseases are significant causes of mortality in industrialized nations. It is well established that tissue damage results from ischemia (insufficient blood flow to a tissue) followed by reperfusion (reflow of blood to the tissue). Ischemia and reperfusion cause disturbance of microcirculation with ensuing tissue damage and organ dysfunction. Organs such as the kidney, heart, liver, pancreas, lung, brain and intestine are known to sustain damage following ischemia and reperfusion.

15

In ischemic conditioning (IC), a tissue or organ or region of a subject's body is deliberately subjected to brief ischemic episodes, followed by brief reperfusion episodes. IC has been found to render the tissue, organ or region resistant to injury during subsequent ischemic episodes. The phenomenon of ischemic conditioning has been demonstrated in most mammalian tissues. IC is now recognized as one of the most potent innate protective mechanisms against ischemia-reperfusion (I-R) injury.

20

Remote ischemic conditioning (RIC) refers to the deliberate induction of transient ischemia in a subject at a region remote from at least some of the tissue to be protected. Often, RIC includes inducing transient ischemia in a subject's limb to protect organs remote from the limb, such as the myocardium. Myocardial protection has been demonstrated by a variety of remote stimuli, including renal ischemia, liver ischemia, mesenteric artery ischemia, and skeletal muscle hind limb ischemia.

25

RIC, in the broadest sense, involves deliberate induction of an ischemic period followed by a reperfusion period. The ischemic period may involve complete cessation of blood flow (blood flow occlusion). Such ischemic periods may be induced by applying super-

30

systolic pressures on a region of the body, such as for example a limb. Alternatively, ischemic periods may also be induced by applying a less than systolic pressure.

RIC may be performed prior to (pre-), during (per-) and/or following (post-) an ischemic injury or other injury which benefits from RIC. RIC has shown benefit in reducing or preventing damage resulting from, myocardial infarction and trauma, inter alia,

SUMMARY

In one aspect, a device for performing RIC includes an inflatable cuff configured to encircle a limb of a subject and a controller removably attached to the cuff. The controller includes a pump; a manifold in fluid communication with the pump; an outlet in fluid communication with the manifold and in removable fluid communication with the inflatable cuff; a pressure sensor; and a control circuit configured to implement a RIC treatment protocol.

In another aspect, a cuff assembly may be adapted to encircle a limb of a subject. The cuff assembly includes an inner layer, an outer layer, and a bladder disposed between the inner layer and the outer layer. The outer layer includes two flexible foam sections spaced apart in a longitudinal direction of the cuff assembly. The outer layer also includes an intermediate section disposed between the two flexible foam sections. The intermediate section may have a greater rigidity than the two flexible foam sections.

In a further aspect, a device includes an inflatable cuff and a controller attachment section. The inflatable cuff may be configured to encircle a limb of a subject. The cuff has an axial direction substantially parallel to an axis of the limb when the cuff is in the fitted state. The controller attachment section may be operatively attached to the cuff by at least one attachment joint oriented substantially parallel to the axial direction of the cuff. The controller attachment section may include a connector adapted for removable attachment of a controller. The controller attachment section may provide fluid communication between the controller and cuff in a location removed from the connector when the controller is in an attached state.

It should be appreciated that all combinations of the foregoing aspects and additional concepts discussed in greater detail below (provided such concepts are not mutually inconsistent) are contemplated as being part of the inventive subject matter disclosed herein.

The foregoing and other aspects, embodiments, and features of the present teachings can be more fully understood from the following description in conjunction with the accompanying drawings.

BRIEF DESCRIPTION OF THE DRAWINGS

The accompanying drawings are not intended to be drawn to scale. In the drawings, each identical or nearly identical component that is illustrated in various figures is represented by a like numeral. For purposes of clarity, not every component may be labeled in every drawing. Various embodiments of the invention will now be described, by way of example, with reference to the accompanying drawings, in which:

Fig. 1 is a schematic perspective view of an assembled system for remote ischemic conditioning with a removable controller;

Fig. 2 is a schematic perspective view of the system for remote ischemic conditioning depicted in Fig. 1 with the controller removed;

Fig. 3 is a cross sectional view of the system for remote ischemic conditioning depicted in Fig. 1 taken along the line 3-3 in Fig. 1;

Fig. 4 is an exploded schematic perspective view of the cuff of the system depicted in Fig. 1;

Fig. 5 is a schematic top perspective view of the controller attachment section of the system depicted in Fig. 1;

Fig. 6 is a schematic bottom perspective view of the controller attachment section of the system depicted in Fig. 1;

Fig. 7 is a schematic bottom perspective view of the controller of the system depicted in Fig. 1;

Fig. 8 is a schematic top perspective view of the controller of the system depicted in Fig. 1;

Fig. 9 is a cross sectional view of the controller and controller attachment section while coupled to the system depicted in Fig. 1;

Fig. 9A is a detailed view of Fig. 9 corresponding to box A of Fig. 9;

Fig. 10 is a schematic perspective view of the controller of the system depicted in Fig. 1 with the cover removed;

Fig. 11 is a schematic perspective view of the controller of the system depicted in Fig. 1 with the cover and PCB removed;

Fig. 12. is a schematic perspective view of a charging cradle to be used with the controller; and

Fig. 13 is a schematic perspective view of the charging cradle of Fig. 12 with an optional wall mount.

DETAILED DESCRIPTION

5 The illustrative embodiments described herein are not necessarily intended to show all aspects of the invention. Aspects of the invention are not intended to be construed narrowly in view of the illustrative embodiments. It should be appreciated that the various concepts and embodiments introduced above and those discussed in greater detail below may be implemented in any of numerous ways, as the disclosed concepts and embodiments are not
10 limited to any particular manner of implementation. In addition, it should be understood that aspects of the invention may be used alone or in any suitable combination with other aspects of the invention.

In one aspect, a system for performing RIC includes an inflatable cuff, a controller attachment section joined to the cuff, and a controller selectively removable from the controller
15 attachment section. The controller may control the inflation and deflation of the inflatable cuff. Furthermore, the controller may include a control circuit programmed to implement an RIC protocol. In another aspect the cuff may be soft, rigid, and made from thermoformable materials.

Turning now to the figures, several possible embodiments are described in further
20 detail.

Figs. 1 and 2 illustrate one embodiment of a system 2 for RIC. System 2 may include an inflatable cuff 4, a controller attachment section 6, and a controller 8. In some embodiments, as depicted in Fig. 2, the controller 8 is selectively removable from system 2. The controller attachment section 6 may include an interlocking retaining tab 10 adapted to
25 provide removable attachment of the controller. The controller attachment section may also include a conduit 12 that provides, sealed, fluid communication between the controller 8 and inflatable cuff 6.

In one aspect, cuff 4 is axially rigid while being soft or non-irritating to the skin. In one embodiment, cuff 4 may include an inner layer 16, a layer 18, and a selectively inflatable
30 bladder 20 disposed between layers 16 and 18, as depicted in Fig. 4. Cuff 4 may be adapted to encircle a limb of an individual. Axis 15 represents the approximate center of a circular configuration formed when cuff 4 is wrapped about a patient's limb. An axial direction of cuff 4 corresponds to the approximate direction of axis 15. Cuff 4 has a longitudinal direction

extending down the length of cuff 4 which is substantially perpendicular to the above defined axial direction. Cuff 4 may also be intended to be a disposable item for use with removable controller 8. Inner layer 16 typically is positioned adjacent to, and often in contact with, the skin of an individual wearing system 2. Since inner layer 16 may be in contact with skin, the inner layer may be made from a soft and/or non-irritating material. The inner layer 16 may be made from a knit, woven, or felted cloth. The cloth may include either natural or synthetic materials. Possible cloths include brushed polyester, brushed nylon, and/or other suitable materials as would be apparent to one of skill in the art. Alternatively, inner layer 16 may be made from a foam. In some embodiments, inner layer 16 may be further adapted to provide moisture absorption, wicking, and/or breathability to cuff 4.

In some embodiments, cuff 4 may include two sections 22 spaced apart in a longitudinal direction and an intermediate section 24 disposed between the sections 22. Intermediate section 24 may be constructed to have a greater rigidity than sections 22. The increased rigidity of the intermediate section 24 may be created either by an inherent material property difference, a difference in the physical construction (e.g. a thicker section and/or inclusion of reinforcing features), or both. In one embodiment, the intermediate section 24 may include a substantially flat outer surface 25 for attachment to the controller attachment section 6. Intermediate section 24 may also include an inner surface 26 which is curved in the longitudinal direction of the cuff 4. The curved inner surface 26 may be constructed so as to generally conform to the curvature of a limb. In some embodiments, the size and curvature of the cuff 4 may be suited for a variety of sizes and ages of patients ranging from neonates to obese adults. The cuff 4 may also be sized for either attachment to an arm or a leg. The intermediate section 24 may be constructed from thermosetting plastics, thermoforming plastics, and/or foamed materials. Sections 22 and the intermediate section 24 may be integrally formed with one another, or they may be formed separately and subsequently joined using any appropriate method including, but not limited to, a sewn seam, ultrasonic welds, adhesives, rivets, clamping structures, and/or mechanically interlocking features. Section 22 may be formed of a foam material or any other suitably flexible yet strong material.

In one embodiment, cuff 4 may also include a plurality of reinforcing structures 28 substantially aligned in the axial direction of the cuff assembly. Reinforcing structures 28 typically may be formed in outer layer 18 of sections 22. Reinforcing structures 28 provide axial rigidity to the cuff 4. The increased axial rigidity provided by reinforcing structures 28 helps to distribute the pressure applied by cuff 4 in the axial direction to provide a substantially

uniform pressure across the axial width of the cuff 4. Reinforcing structures 28 may also help to prevent kinks in cuff 4 when it is placed around the arm or leg of an individual. Reinforcing structures 28 may be spaced apart in a longitudinal direction to permit the cuff 4 to easily bend around an encircled limb while still providing increased axial rigidity. Reinforcing structures 28 may be curved or straight in shape in the axial direction. In some embodiments, the reinforcing structures 28 may be integrally formed with the foam in sections 22 such as by the application of heat and/or pressure (e.g. thermoforming) to selectively melt and/or compress portions of the foam in sections 22. The uncompressed and/or unmelted portions of foam in sections 22 form the raised reinforcing structures 28. Alternatively, reinforcing structures 28 may be separately formed and subsequently joined to sections 22.

Layer 18 may also include a cloth layer 19 applied to an exterior surface. Cloth layer 19 may be formed of a low stretch or non-stretch cloth. The low stretch or non-stretch properties may be an inherent property of the cloth selected. Alternatively, cloth layer 19 may be made from thermoformable materials and may be laminated to the exterior surface of layer 18. The lamination process may alter the thermoformable fabric to be a low stretch or non-stretch material. In one embodiment, the cloth may be applied to and laminated with layer 18 in a flat layout prior to forming reinforcing structures 28. Reinforcing structures 28 may subsequently be thermoformed to a final desired shape. The resulting sections 22 may be soft and have low stretch or non-stretch properties. Furthermore, sections 22 may be thermoformable enabling subsequent processing steps.

Selectively inflatable bladder 20 may be disposed between inner layer 16 and layer 18. Bladder 20 may have a valve 30 arranged and adapted to provide a fluid inlet to the interior of bladder 20. Valve 30 extends through a hole 32 in the intermediate section 24 of cuff 4. Valve 30 may be placed in sealed fluid communication with a corresponding structure 33 on controller attachment section 6 which may also be in sealed fluid communication with an outlet 48 of controller 8. When connected to outlet 48 of controller 8 through structure 33 of the controller attachment section 6, valve 30 may provide pressurized gas such as air to bladder 20. In some embodiments, bladder 20 may be a component separate from layers 16 and 18. Bladder 20 may be formed such as by bonding two separate sheets of thermoplastic polyurethane together. In other embodiments, bladder 20 may be formed from air impermeable layers incorporated into layers 16 and 18 of cuff 4. Layers of bladder 20 may be bonded together in an air tight manner using any number of methods including adhesives, ultrasonic welding, beads of material around the edges, and/or other appropriate methods as

would be apparent to one of skill in the art. Bladder 20 may also be formed as a unitary structure without separate layers.

Layers 16, 18, 19, and bladder 20 of cuff 4 may be held together at their edges in any suitable fashion, such as by a binding material 36 wrapped around the edge of cuff 4 and sewn to cuff 4, as shown in Fig. 4. Alternatively, cuff 4 may be held together using adhesives, rivets, ultrasonic welds, or other appropriate methods as would be apparent to one of skill in the art.

In one aspect, it may be desirable to provide a non-slip interface to prevent cuff 4 from moving on the limb of a subject, since system 2 may be worn for protracted periods of time. To provide a non-slip interface, at least one non-slip structure 34 may be disposed on the face of inner layer 16. The non-slip structure 34 may be printed, glued, sewn, applied as a bead of material using a guided tool, or by hand. The non-slip structure 34 may include, but is not limited to, one or more strips of silicone.

The cuff 4 may also include fasteners to hold the cuff on a limb of a subject and to adjust the circumferential size of the cuff 4 when in the fitted state. Such fasteners include, but are not limited to, hook and loop fasteners, latches, ratchet mechanisms, clasps, snaps, buckles, and other appropriate structures as would be apparent to one of skill in the art. For example, the fastener may be a hook and loop fastener including a plurality of adjacent unconnected hook sections 38a disposed on layer 18 or 19 and loop sections 38b disposed on inner layer 16. Hook sections 38a may extend in the axial direction of the cuff 4. The width of each hook section 38a, with respect to the longitudinal direction of the cuff, may be selected to provide a flexible cuff able to wrap around different sized limbs.

The controller attachment section 6 of Fig. 1 is shown in more detail in Figs. 3, 5 and 6. In one embodiment, controller attachment section 6 may include an upper surface 40 for supporting controller 8 in the attached state, a lower surface 44, and an upstanding wall 42 surrounding surface 40. A raised portion 43 of upstanding wall 42 may be located adjacent to and block a power inlet 52 of controller 8 in the attached state. By blocking access to power inlet 52 in the attached state, raised portion 43 may prevent use of the device while controller 8 is connected to an external power source. The controller attachment section 6 may also include a connector, such as retaining tab 10, arranged to provide removable attachment of controller 8. In one embodiment, tab 10 is mounted at one end to surface 40 and includes a projecting edge 41 spaced from surface 40 that faces outwardly towards wall 42. Bosses 45 are disposed on wall 42 on the opposite side of section 6 from tab 10. When controller 8 is attached to attachment section 6, the upper portion of tab 10 is pushed inwardly away from wall 42 so that

it passes through slot 49 that is disposed between the body of controller 8 and an outer band 51, as shown in Fig. 7. At the same time, bosses 45 extend into recesses 53 of controller 8, as shown in Fig. 8. Tab 10 has sufficient resilience that when snapped into place, this resilience creates an outward bias on tab 10 that causes edge 41 to overlie the upper edge of band 51. To
5 release controller 8, the upper portion of tab 10 is again pushed inwardly against its bias toward controller 8 until edge 41 overlies slot 49 and is clear of band 51 at which time controller 8 may be pulled out of attachment section 6 at the end closest to tab 10.

In one embodiment, lower surface 44 and/or bottom edge 46 of controller attachment section 6 may be disposed on and substantially conform to the shape of an outer surface of
10 cuff 4. In some embodiments, bottom surface 44 and/or bottom edge 46 of the controller attachment section 6 may be disposed on and substantially conform to the shape of outer surface 25 of intermediate section 24 of cuff 4 shown in Fig. 4. As shown in Fig. 3, the controller attachment section 6 may be joined to outer surface 25 of intermediate section 24 of inflatable cuff 4 along lower surface 44 by at least one and typically two attachment joints 14.
15 In one embodiment, the attachment joint(s) 14 may be oriented substantially parallel to axis 15 of the cuff. The attachment joint 14 may be formed using any appropriate method including, but not limited to, a sewn seam, an ultrasonic weld, an adhesive, and/or rivets. When two or more attachment joints 14 are included, the joints 14 may be spaced apart in the longitudinal direction to allow the cuff 4 to bend and conform to the shape of different sized limbs.

20 As shown in Figs. 9 and 9A, controller attachment section 6 may provide fluid communication between the controller 8 and bladder 20 of cuff 4 via structure 33. Structure 33 may include a conduit 12 which is provided in a location spaced from retaining tab 10, when the controller 8 is in an attached state. Conduit 12 fluidly couples controller 8 to valve 30 of bladder 20. Conduit 12 may include a female section 12a that is constructed and arranged to
25 mate with an outlet 48 of controller 8 and a male section 12b that is constructed and arranged to mate with valve 30 of bladder 20. While a male and female connection have been described, the male and female portions could be reversed or even replaced with other comparable fluid connections, such as a tube or the like. A seal, such as O-ring 60, may be disposed on a shoulder 59 located in structure 33. The O-ring 60 may create a gland seal
30 between female section 12a and outlet 48. Alternatively, a compression seal with O-ring 60 may be used. A retaining structure 61 may be included in structure 33 to retain O-ring 60. Retaining structure 61 may be joined to structure 33 using any appropriate method including, but not limited to, press fitting, ultrasonic welding, and/or adhesives.

As shown in Fig. 8, controller 8 has a front cover 50, which may include controls and displays, and a power inlet 52. Guide structures 54 may be included in controller 8 for alignment and/or engagement with a charging mechanism

The internal components of controller 8 are best shown in Figs. 10 and 11, where front cover 50 of controller 8 has been removed. Controller 8 may include a pump 62 in fluid communication with a manifold 64. Manifold 64 is in fluid communication with relief valve 68 and outlet 48. Controller 8 may also include a printed circuit board (PCB) 66 which may include a control circuit and memory. The controller 8 may also include a pressure sensor associated with the pressurized components of the system and the control circuit. The pressure sensor (not shown) may be incorporated into pump 62 and/or placed in pressure sensing communication with manifold 64. Furthermore, the pressure sensor may communicate with the control circuit of PCB 66. The control circuit may be programmed to implement an RIC treatment protocol. The controller may also determine blood pressure during, or as part of, an RIC treatment protocol. To provide convenient mobile usage of system 2, batteries 70 may be arranged, typically in series, to provide a higher operating voltage. Alternatively, batteries 70 may be in electrical communication with a transformer adapted to provide a higher operating voltage. In one embodiment, the operating voltage may be approximately 5 to 6 VDC. In other embodiments, the operating voltage may be approximately 12 VDC or any other appropriate voltage. As shown in Fig. 11, PCB 66 may be connected to the other controller components through plug connector 72.

The control circuit of PCB 66 may be programmed with certain error conditions which may cause the procedure to be aborted or which may cause an indication of the error to appear on a display or which can be used in other known ways. These error conditions may include, but are not limited to: the cuff is not pressurized within a predefined period, such as 20 seconds, 30 seconds, 40 seconds, 50 seconds, or one minute; there is no communication between pump 62 and PCB 66 upon start up; there is no communication between pump 62 and PCB 66 for more than a predefined period, such as two, three, four, or five seconds; multiple consecutive repumps are needed to maintain cuff pressure; pump 62 continues to run and does not respond to an abort signal after a predefined number of retries, such as three, four, or five retries; pressure in cuff 4 is not near zero gage pressure within a predefined period, such as 20 seconds, 30 seconds, 40 seconds, 50 seconds, or one minute after the end of an inflation cycle; pressure in cuff 4 is above a predetermined pressure such as 200, 220, 240 or 260 mmHg for longer than a predefined period, such as 5, 10, 20, or 30 seconds; and the pump 62 CPU does

not wake up after a command is sent to it by the control circuit. The error condition may be cleared and/or the system may be reset such as by pressing a stop button 76 on the face of controller 8.

During usage, controller 8 may be attached to controller attachment section 6 to place
5 controller outlet 48 into fluid communication with cuff 4. Pressurized gas may then be pumped through controller outlet 48 to inflate the cuff 4. The cuff pressure may be controlled by selectively opening valve 68 in response to a command from the control circuitry of PCB 66. In some embodiments, valve 68 may include a pressure safety relief feature that opens
10 valve 68 in response to an over pressure event during an RIC treatment. In one embodiment, valve 68 opens when the pressure in cuff 4 exceeds 260 mmHg. Valve 68 may open in response to either an error command from the control circuitry of PCB 66, or the valve 68 may include an automatically actuated mechanical system. Controller 8 may also include a slow continuous relief valve. Such a valve would continuously release gas from inflated bladder 20 at a selected rate lower than the rated flow rate of the pump 62. The slow continuous release of
15 gas from bladder 20 could be used to deflate bladder 20 in case of a mechanism failure.

In some embodiments, the control circuit of PCB 66 may be programmable by a health professional and/or an end user according to a prescribed treatment protocol. Alternatively, the control circuit may only be programmed at the factory and may not be altered afterwards by the end user. The control circuitry may also include non-volatile memory for the logging and
20 storage of treatment history. A health care professional may be able to access this memory to determine the treatment history of a patient and determine compliance with a prescribed treatment regime. In another embodiment, the controller may send this information via wireless, or hard wired, communication to a separate receiver for patient records, monitoring, or call center purposes. In one embodiment, controller 8 may include a start button 74 and stop
25 button 76. In some embodiments, the start and stop buttons 74 and 76 may be incorporated into a single button. Controller 8 may also include a hard wired and/or emergency stop button and/or a quick release valve (not shown). In other embodiments, other controls may be included to allow expanded control of an RIC treatment.

In addition to controls, controller 8 may include displays related to the current cycle,
30 the number of cycles left in a treatment, whether the treatment is completed, error signals, charge of the system, and other relevant information. In one embodiment, controller 8 may include a cycle time display 78. Cycle time display 78 may indicate the remaining portion of the inflation/deflation cycle by using illuminated indicators 78a arranged in a circular pattern

corresponding to a full inflation/deflation cycle. Each indicator 78a of cycle time display 78 may correspond to a set fraction of the inflation/deflation cycle. When all of the indicators 78a of cycle time display 78 are illuminated, the inflation/deflation cycle is complete.

Alternatively, the indicators 78a of cycle time display 78 may start a cycle fully illuminated and sequentially turn off as the cycle proceeds. When each indicator 78a of cycle time display 78 is dark, the particular inflation/deflation cycle is complete. While a circular display has been disclosed, cycle time display 78 could also be arranged in other linear, or non-linear, shapes corresponding to a full cycle. Controller 8 may also include a current cycle display 80, or a digital numeric display, indicating whether the current cycle is the first, second, third, or other cycle. A procedure complete indicator 82 may be illuminated with a solid color or it may blink when the RIC treatment is complete to indicate the end of the procedure. An error display 84 may indicate when an error has occurred by blinking or being fully illuminated. Alternatively, error display 84 may blink in a preset pattern or display a particular color to indicate which error has occurred. A battery charge indicator 86 may indicate the approximate charge remaining in the batteries 70, and may also signal that that the remaining charge is only sufficient for one cycle by blinking.

The above described system may be used for implementing an RIC treatment. The treatment includes placing cuff 4 on a limb of a user and attaching controller 8 to controller attachment section 6 on cuff 4. A user may then press start button 74 to initiate the treatment. Once started the control circuitry of PCB 66 monitors the pressure sensor and turns pump 62 on to inflate the cuff 4. The pressure is then increased to a desired pressure, such as a blood flow occlusion pressure. In one embodiment, the control circuitry of PCB 66 maintains the cuff pressure between preselected pressure limits such as 200 mmHg to 210 mmHg. In other embodiments, the control circuitry of PCB 66 may first determine a systolic blood pressure. After determining a systolic blood pressure, the control circuitry of PCB 66 may subsequently initiate the RIC treatment protocol with a desired pressure such as a pressure greater than the measured systolic blood pressure. Regardless of the specific pressure used, the pressure may be maintained for a selected ischemic duration. Ischemic durations may last on the order of seconds or minutes. After completing the ischemic duration, the controller may activate valve 68 to deflate cuff 4 and initiate the reperfusion duration. Reperfusion durations generally last for at least a minute, although shorter reperfusion durations may be used. After completion of the reperfusion duration another RIC cycle may be conducted. An RIC treatment may include a single cycle or multiple cycles. In one embodiment, an RIC treatment may include four

cycles with ischemic durations of approximately 5 minutes, and reperfusion durations of approximately 5 minutes. At the end of the last cycle the cuff 4 may deflate within 30 seconds and the controller 8 may confirm a near zero gage pressure prior to shutting down.

In some embodiments, controller 8 may be charged using a charging cradle 88, as shown in Fig. 12. Charging cradle 88 may include a power connector 90 and mating guide structures 92. In one embodiment, mating guide structures 92 on the charging cradle mate with guide structures 54 on the controller. Mating guide structures 92 act as alignment features. In other embodiments, mating guide structures 92 may be actuated when controller 8 is inserted into the charging cradle 88 to turn the power on and off to power connector 90. Charging cradle 88 may also include a raised area 94 to prevent insertion of the controller while controller 8 is connected to cuff 4 or a patient. In addition to the above, charging cradle 88 may optionally connect with a wall mount portion 96 as shown in Fig. 13.

While the present teachings have been described in conjunction with various embodiments and examples, it is not intended that the present teachings be limited to such embodiments or examples. On the contrary, the present teachings encompass various alternatives, modifications, and equivalents, as will be appreciated by those of skill in the art. Accordingly, the foregoing description and drawings are by way of example only.

What is claimed is:

CLAIMS

1. A device for remote ischemic conditioning comprising:
an inflatable cuff configured to encircle a limb of a subject;
a controller removably attached to the cuff, wherein the controller comprises:
5 a pump;
a manifold in fluid communication with the pump;
an outlet in fluid communication with the manifold and in removable fluid
communication with the inflatable cuff;
a pressure sensor; and
10 a control circuit configured to implement a remote ischemic conditioning
treatment protocol.
2. The device of claim 1, wherein the controller further comprises at least one valve
configured to open in response to an over pressure event.
15
3. The device of claim 1, wherein the control circuit maintains a cuff pressure between
preselected pressure limits during an ischemic duration of the remote ischemic conditioning
treatment protocol.
- 20 4. The device of claim 3, wherein the preselected pressure limits are 200 and 210 mmHg.
5. The device of claim 1, wherein the controller is removably attached to the cuff by
selective attachment to a controller attachment section disposed on the cuff.
- 25 6. A cuff assembly for encircling a limb of a subject comprising:
an inner layer;
an outer layer comprising two flexible foam sections spaced apart in a longitudinal
direction of the cuff assembly and an intermediate section disposed between the two flexible
foam sections having a greater rigidity than the two flexible foam sections; and
30 a bladder disposed between the inner cloth layer and the outer layer.
7. The cuff assembly of claim 6, wherein the intermediate section includes a curved inner
surface extending in a longitudinal direction of the cuff assembly.

8. The cuff assembly of claim 6, wherein the two flexible foam sections include a plurality of reinforcing structures substantially aligned in an axial direction of the cuff assembly.

5 9. The cuff assembly of claim 6 further comprising at least one non-slip structure disposed on an exterior face of the inner layer.

10. The cuff assembly of claim 9, wherein the non-slip structure comprises a strip of silicone.

10

11. The cuff assembly of claim 6 wherein the inner layer comprises a cloth.

12. The cuff assembly of claim 11 wherein the cloth comprises a felt.

15 13. The cuff assembly of claim 6, wherein a fluid inlet to the bladder extends from the bladder through the intermediate section of the outer layer.

14. The cuff assembly of claim 6 further comprising a fastener.

20 15. The cuff assembly of claim 14 wherein the fastener comprises a hook and loop fastener.

16. A device comprising;

an inflatable cuff configured to encircle a limb of a subject, wherein an axial direction of the cuff is substantially parallel to an axis of the limb when the cuff is in the fitted state; and

25 a controller attachment section operatively attached to the cuff by at least one attachment joint oriented substantially parallel to the axial direction of the cuff, wherein the controller attachment section includes a connector adapted for removable attachment of a controller, wherein the controller attachment section provides fluid communication between the controller and cuff in a location removed from the connector when the controller is in an
30 attached state.

17. The device of claim 16, wherein the at least one joint comprises at least two joints oriented substantially parallel to the axial direction of the cuff and spaced apart in a longitudinal direction of the cuff.

5 18. The device of claim 16, wherein a bottom surface of the controller attachment section substantially conforms to an outer surface of the cuff.

19. The device of claim 16, wherein the at least one joint comprises a sewn seam, an ultrasonic weld, an adhesive, and/or rivets.

10

20. The device of claim 16, wherein the connector comprises a retaining tab located along a periphery of the controller attachment section.

21. The device of claim 16, wherein fluid communication to the bladder is provided
15 through the controller attachment section.

22. The device of claim 16, wherein the controller attachment section further comprises a conduit that seats in an appropriately configured and sealed receptacle of the inflatable cuff.

20

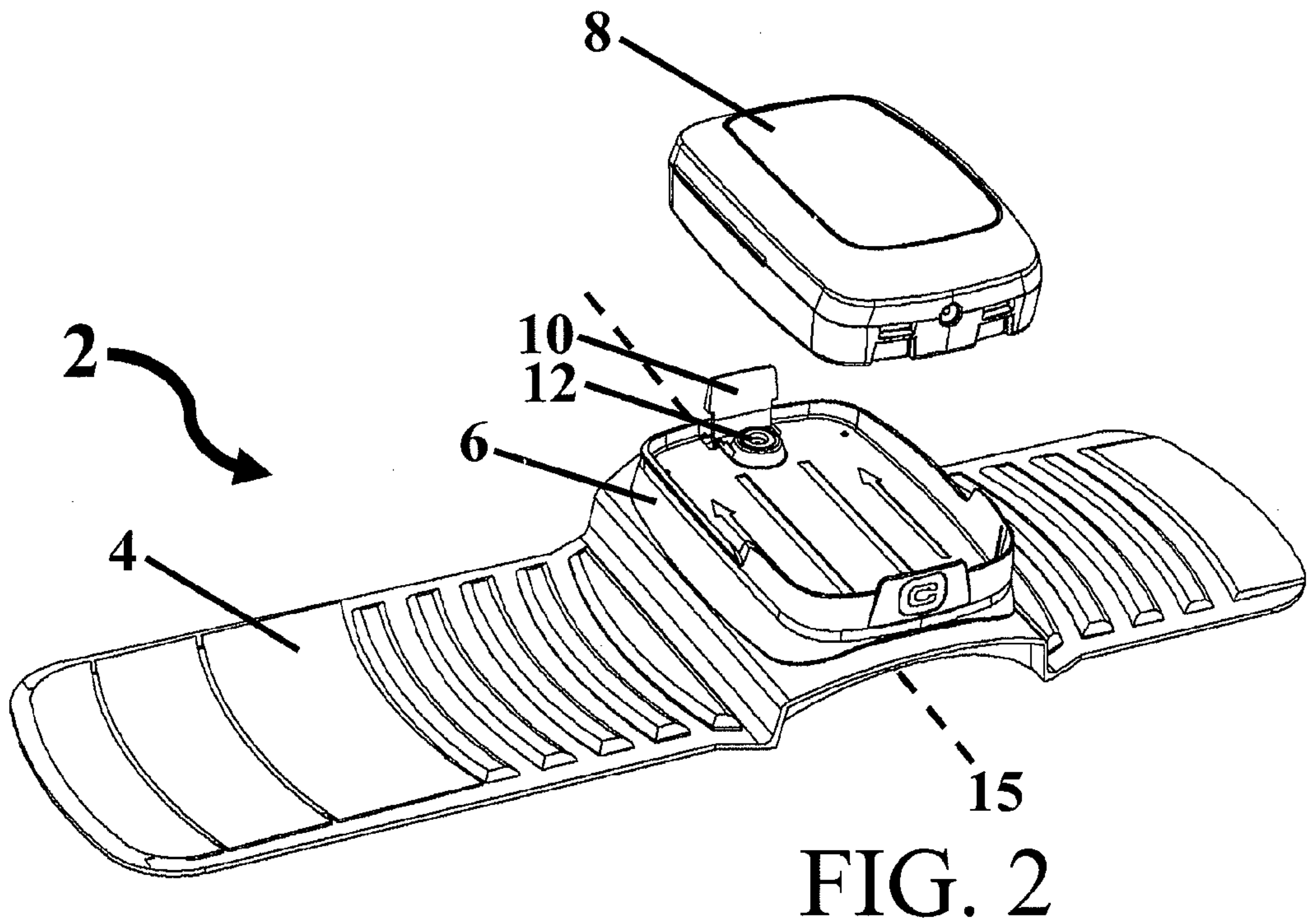
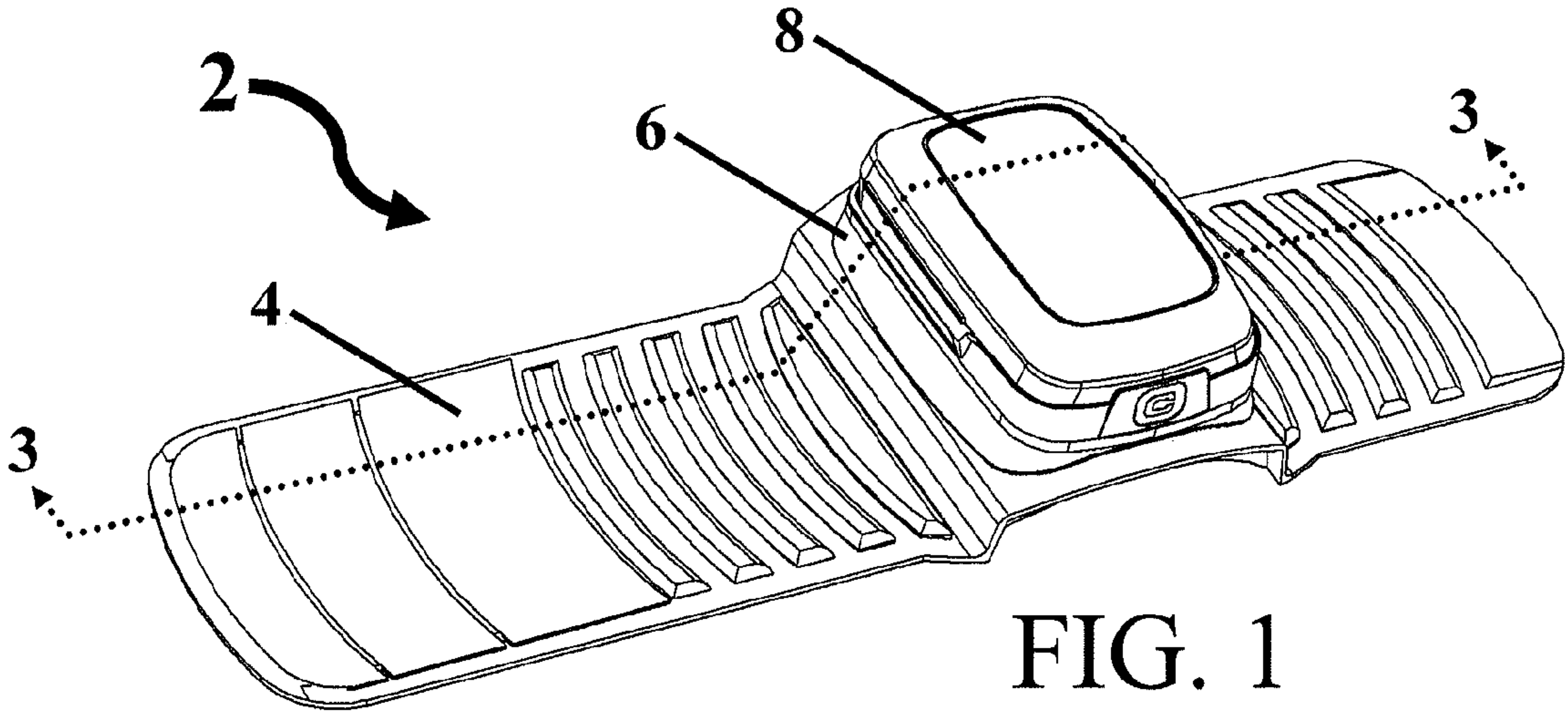

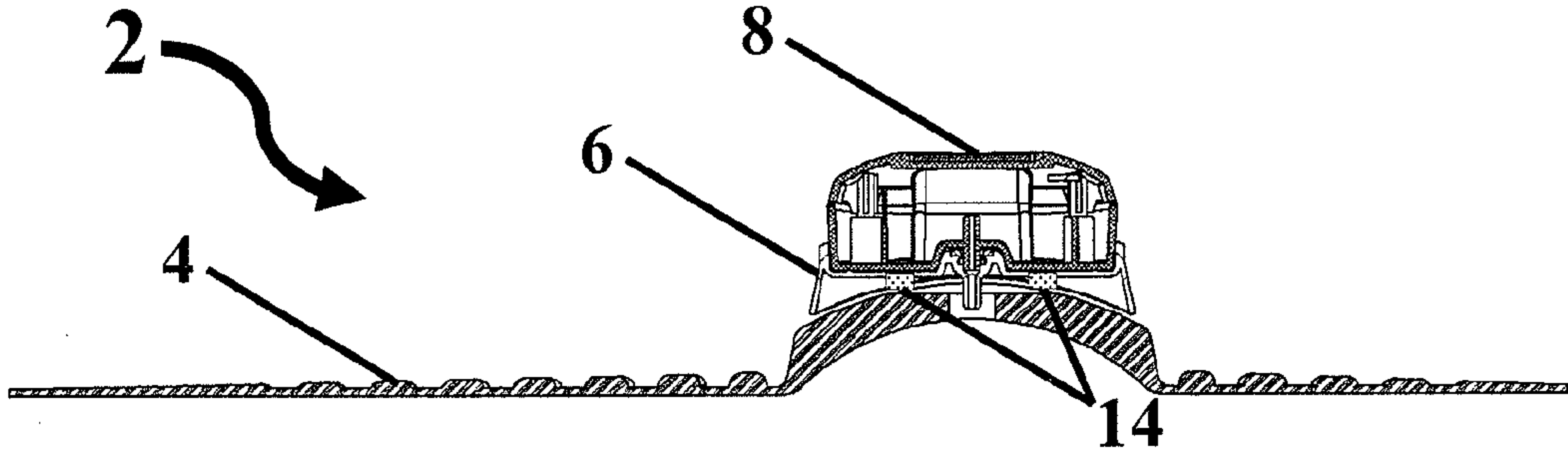

FIG. 3

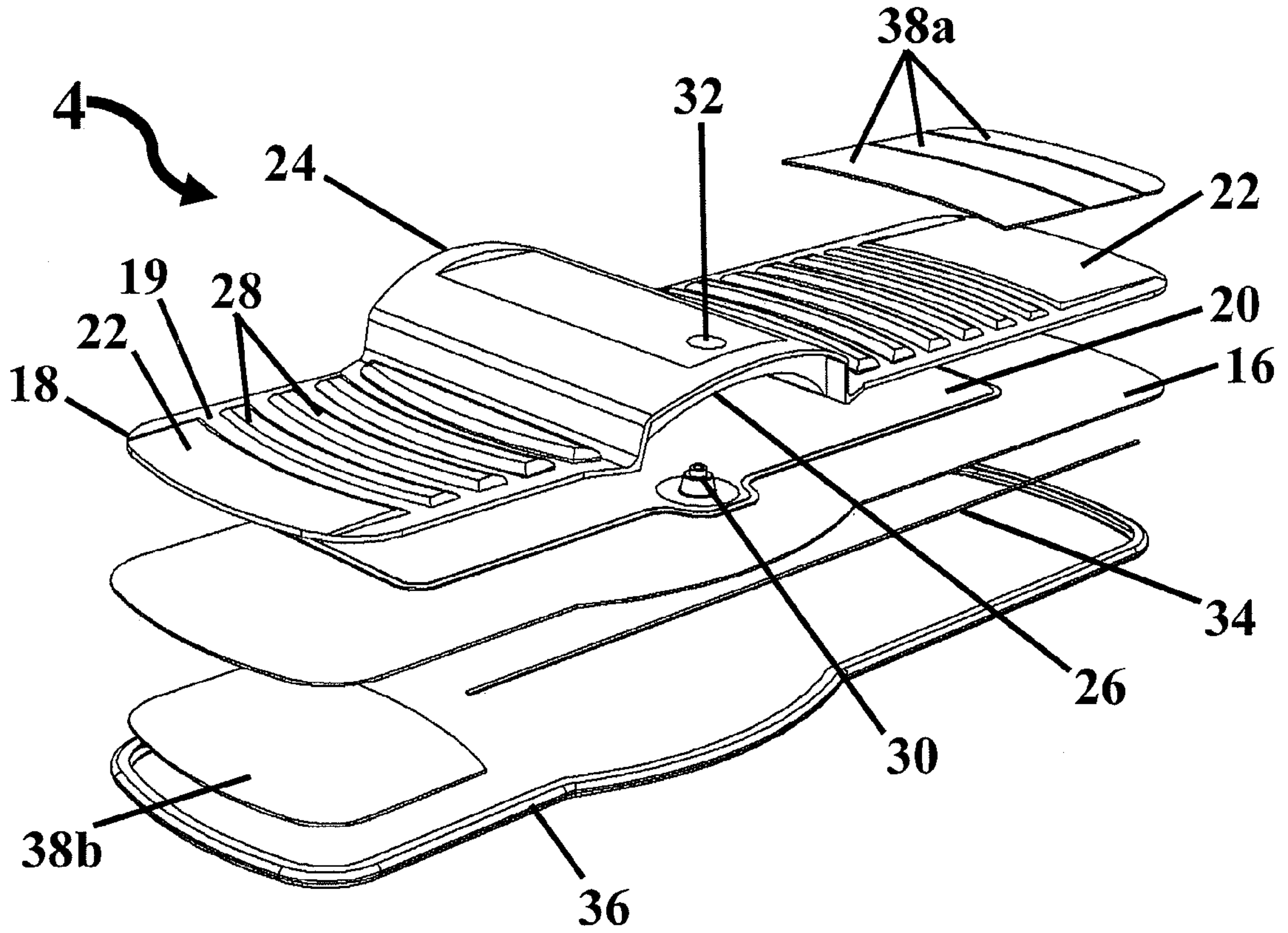
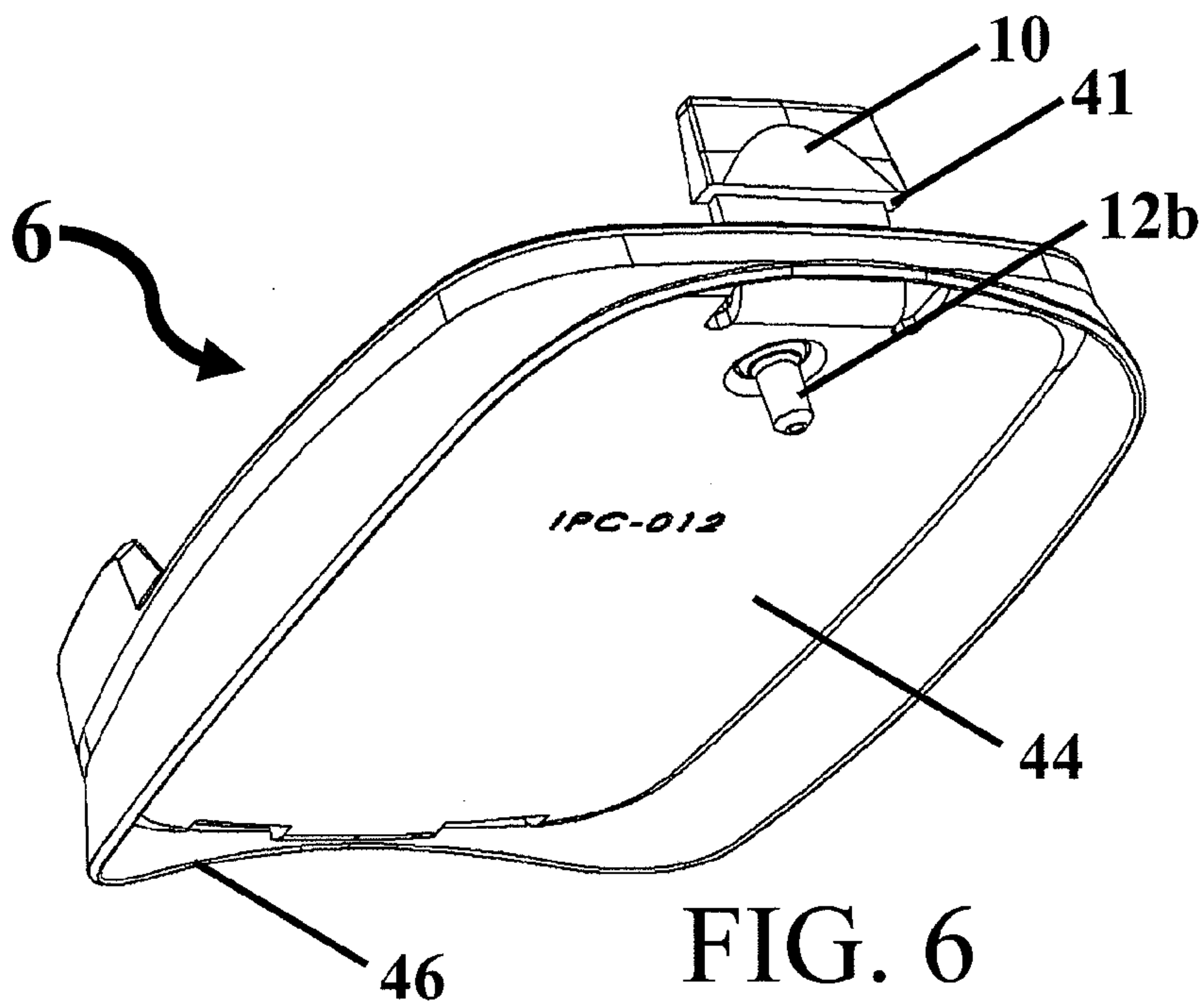
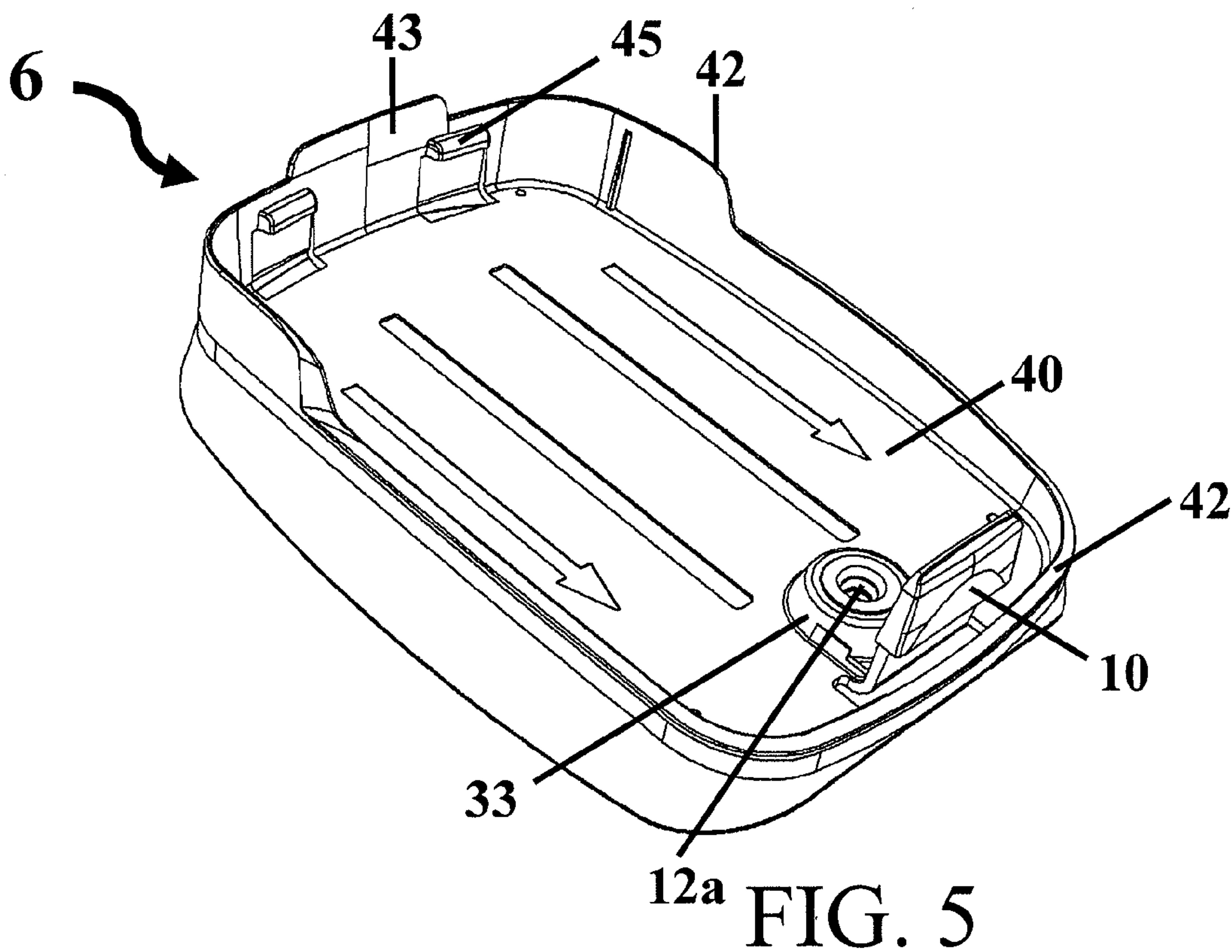

FIG. 4



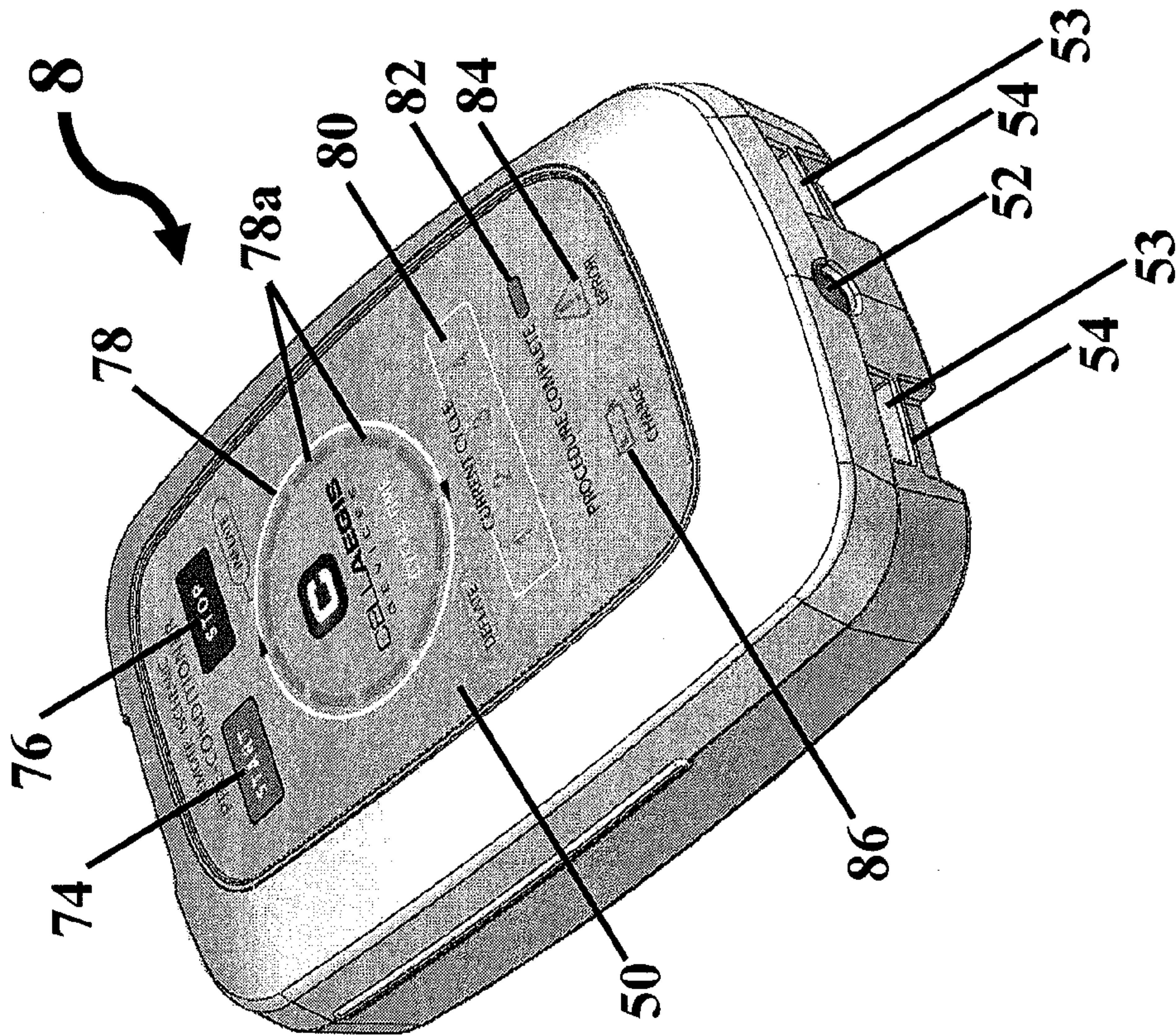

FIG. 8

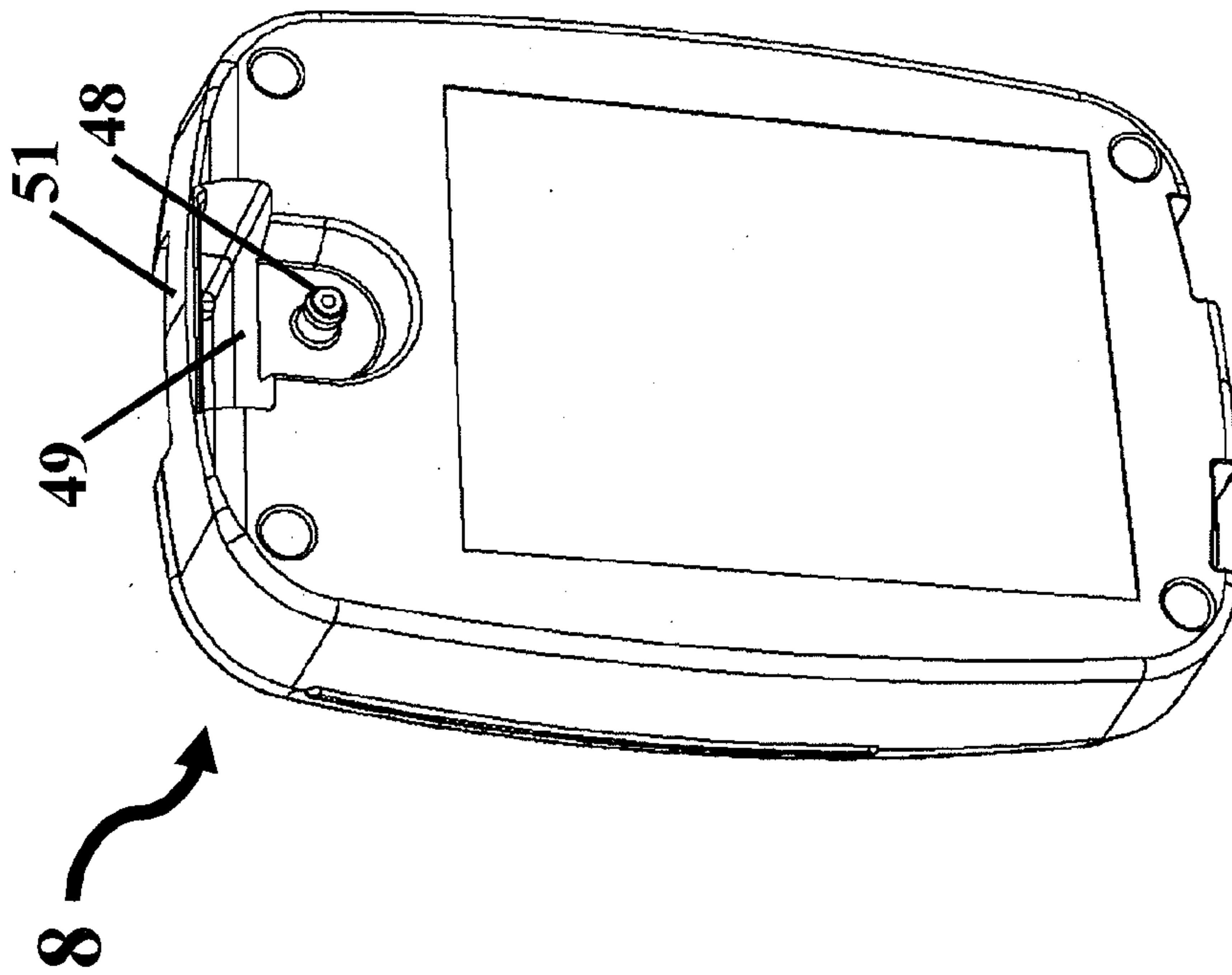

FIG. 7

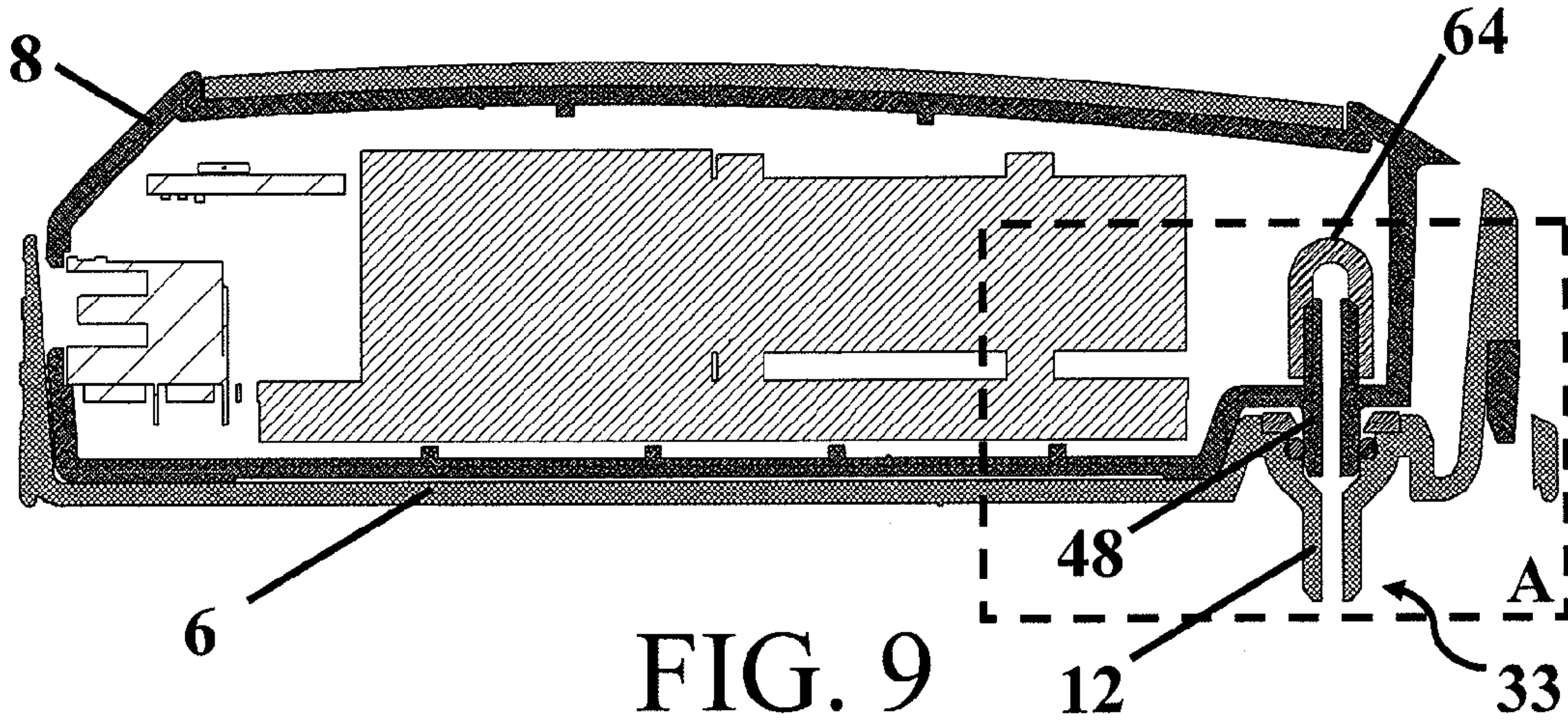

FIG. 9

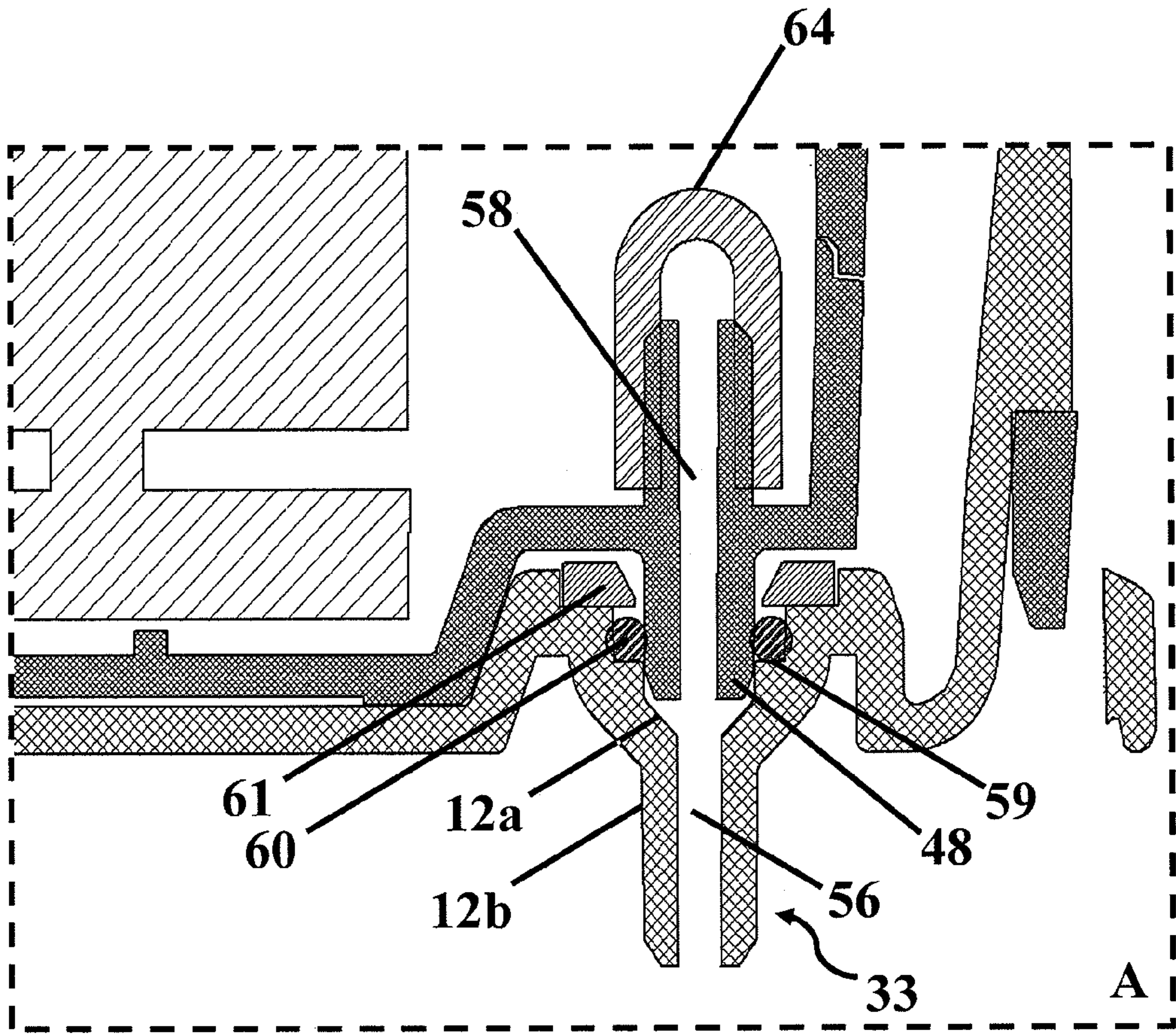

FIG. 9A

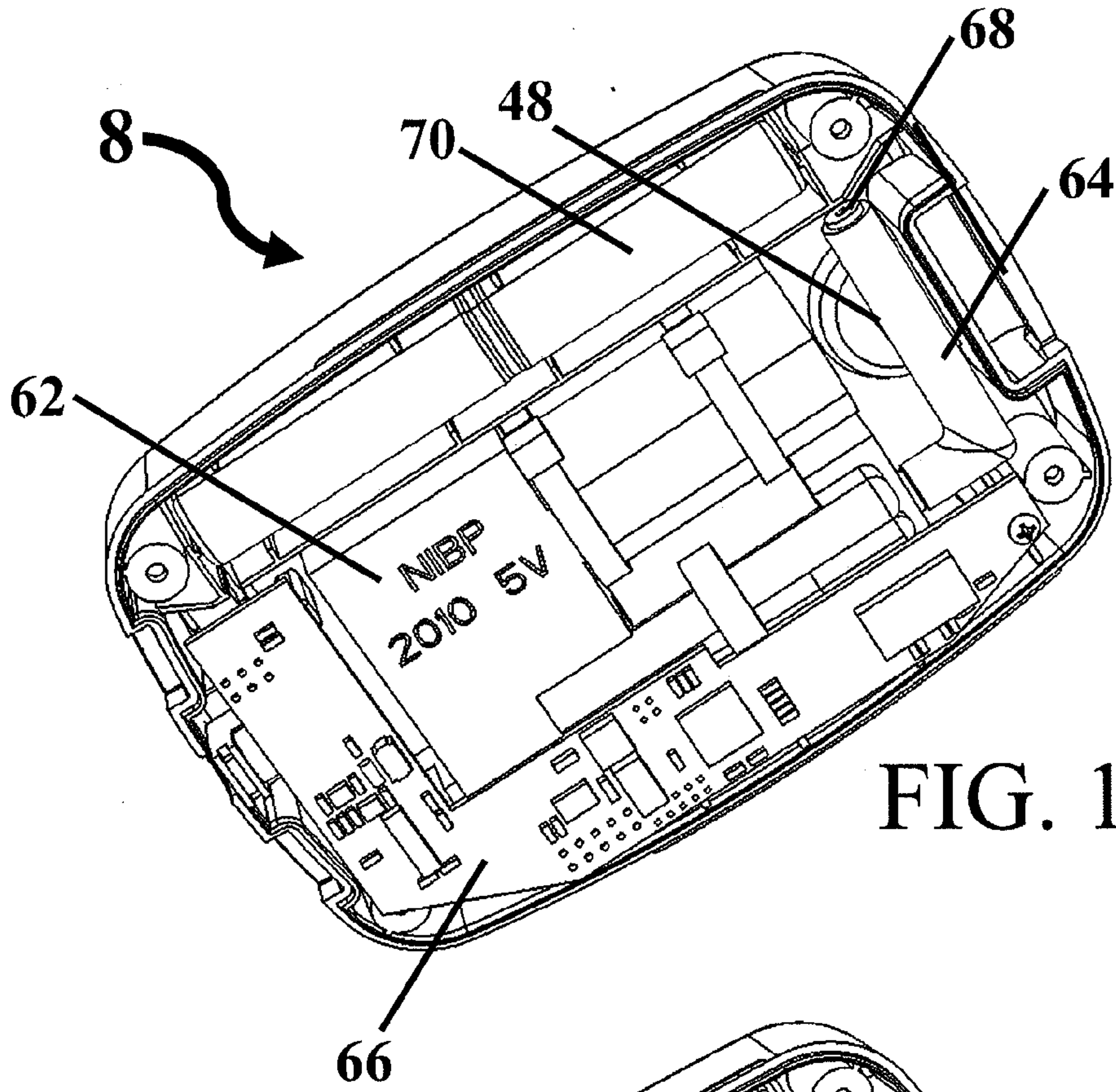

FIG. 10

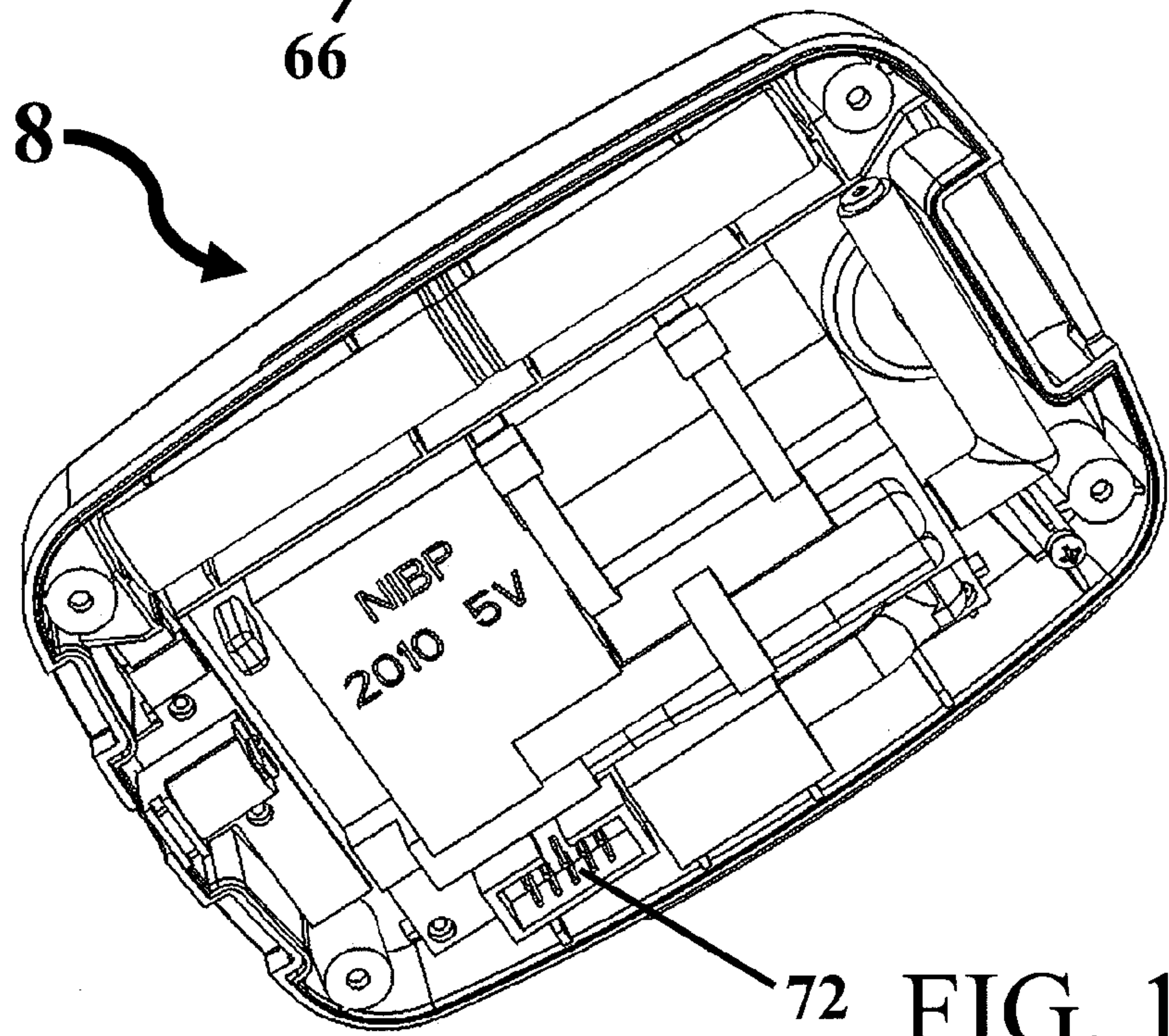

FIG. 11

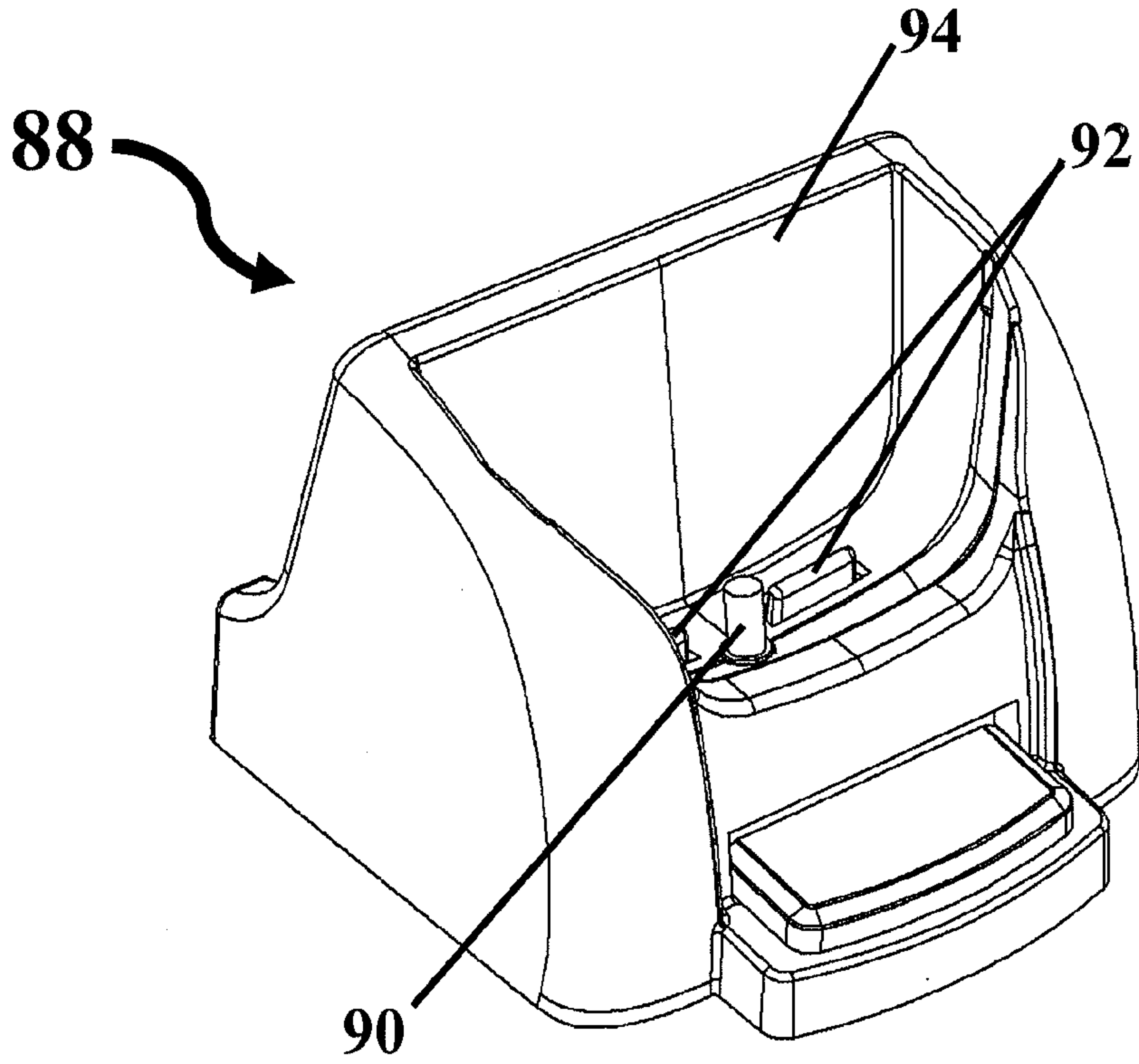

FIG. 12

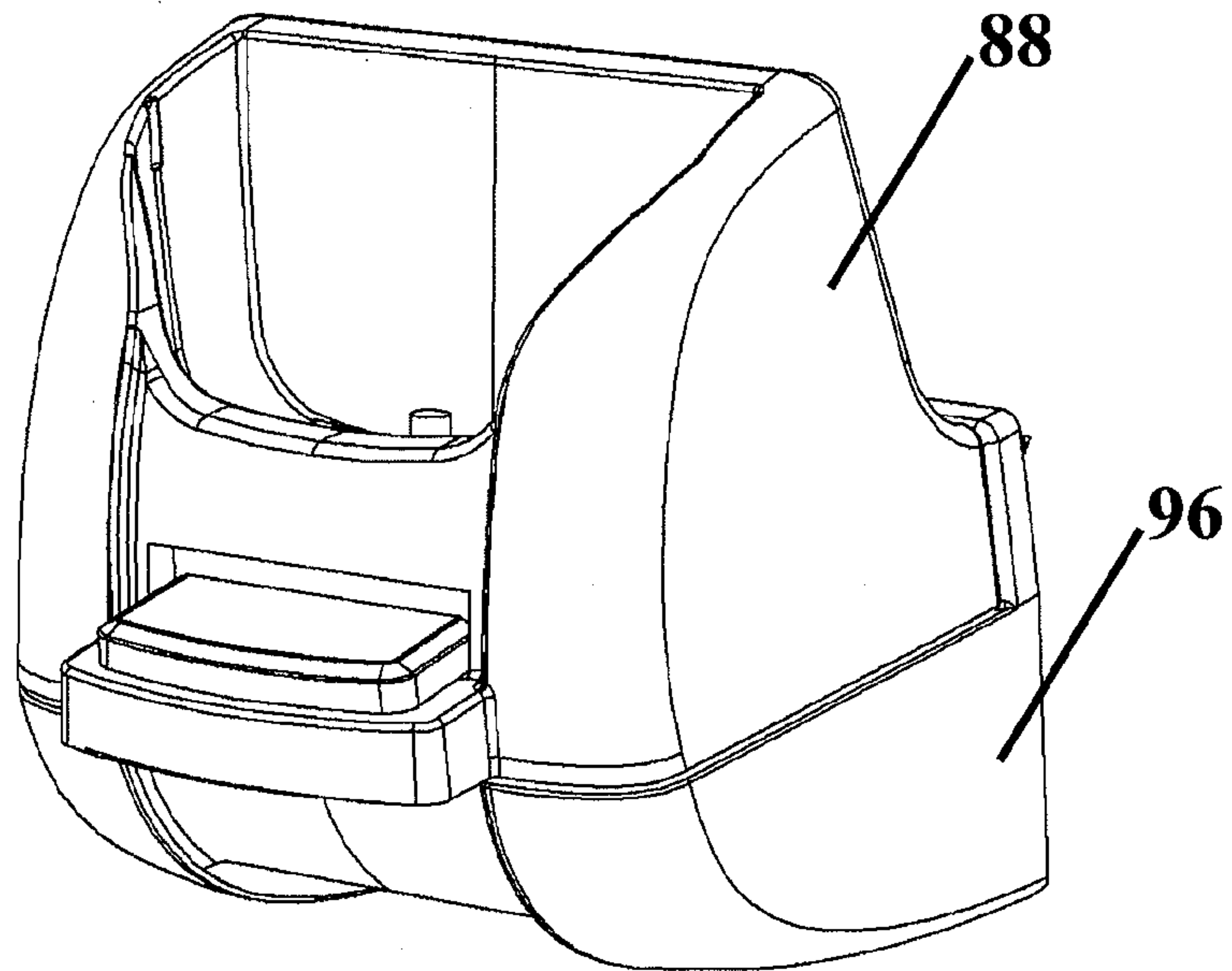

FIG. 13

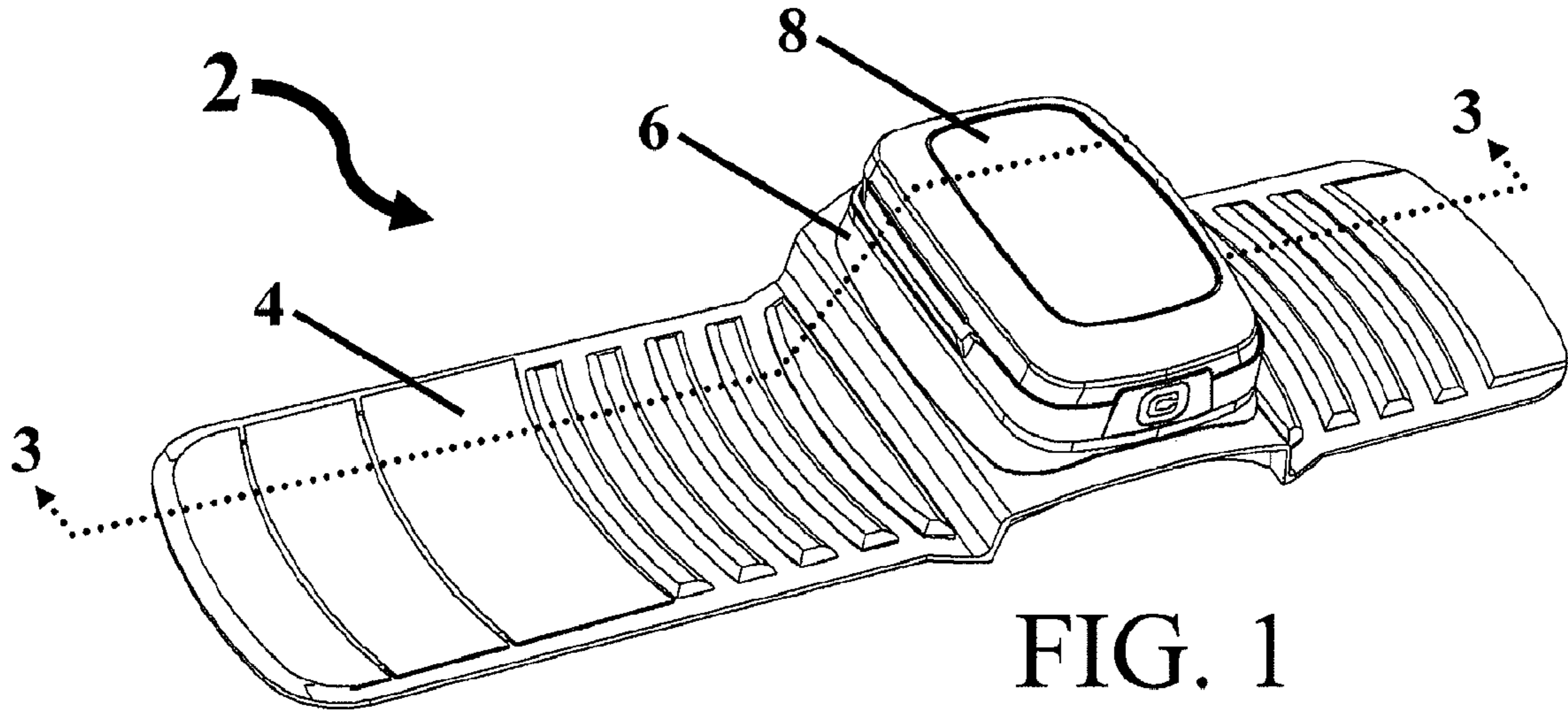

FIG. 1