

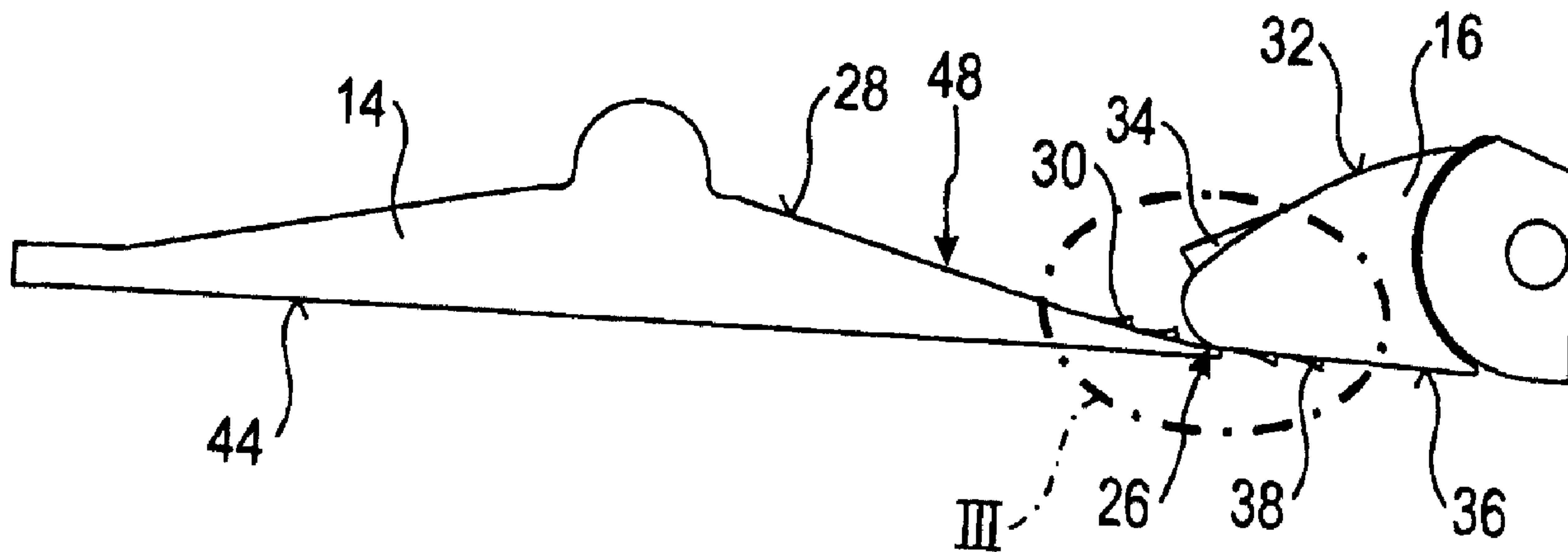

(86) Date de dépôt PCT/PCT Filing Date: 2008/08/05
 (87) Date publication PCT/PCT Publication Date: 2009/02/12
 (45) Date de délivrance/Issue Date: 2013/02/05
 (85) Entrée phase nationale/National Entry: 2010/01/27
 (86) N° demande PCT/PCT Application No.: EP 2008/060260
 (87) N° publication PCT/PCT Publication No.: 2009/019264
 (30) Priorité/Priority: 2007/08/06 (DE10 2007 036 999.0)

(51) Cl.Int./Int.Cl. *B64D 13/02* (2006.01),
F16K 1/22 (2006.01), *F16K 47/04* (2006.01)
 (72) Inventeurs/Inventors:
STEINERT, MARTIN, DE;
KAMEIER, FRANK, DE;
VRANJES, DUSAN, DE
 (73) Propriétaire/Owner:
NORD-MICRO AG & CO. OHG, GB
 (74) Agent: FETHERSTONHAUGH & CO.

(54) Titre : SOUPAPE DE DECHARGE POUR UN AERONEF
 (54) Title: OUTFLOW VALVE FOR AN AIRCRAFT



(57) **Abrégé/Abstract:**

The invention relates to a valve for controlling a fluid flow from a first environment to a second environment, having a frame for disposing a separating element in the region of an opening, said element separating the first environment from the second environment, and a first flap and a second flap for controlling the fluid flow through the opening between the first environment and the second environment, the flaps being movable in the frame. The flaps have protrusions designed to reduce noise generation in the fluid flow.

Abstract

The invention relates to a valve for controlling a fluid flow from a first environment to a second environment, having a frame for disposing a separating element in the region of an opening, said element separating the first environment from the second environment, and a first flap and a second
5 flap for controlling the fluid flow through the opening between the first environment and the second environment, the flaps being movable in the frame. The flaps have protrusions designed to reduce noise generation in the fluid flow.

10 (Fig. 2)

Nord-Micro AG & Co. OHG

PCT/EP2008/060260

60388 Frankfurt
Germany

Our Ref.: 0128 0035 PCT-CA

Outflow Valve for an Aircraft

The present invention relates to a valve for controlling a fluid flow from a first environment to a second environment, having a frame for disposing a separating element in the region of an opening, said element separating the first environment from the second environment, and a first flap and a second flap for controlling the fluid flow through the opening between the first environment and the second environment, the flaps being moveable in the frame.

Such valves are often used to control the pressure in separated environments. Such a separated environment has an inlet valve through which fluid can flow into the environment. The flow of fluid into the separated environment, causes a pressure build-up in the environment. The valve of the initially mentioned type allows a flow cross-section to be controlled as an outlet, by means of which the pressure can be reduced by letting the fluid flow out. The smaller the flow cross-section the higher the pressure remaining in the separated environment.

This principle of pressure control is used, for example, in pressure chambers or in aircraft. Such valves are variously known from the state of the art.

Thus, US 3,426,984 shows an outflow valve for an aircraft. The outflow valve is arranged in an opening in the outer shell of an aircraft. Two valve flaps are pivotably mounted on the edges of the opening and coupled via a mecha-

29126-46

2

nism in such a way that they are commonly pivotable. The flaps are arranged so that they extend toward each other and overlap in a central region when the valve is closed. In this case, the flaps essentially extend flush with the outer shell of the aircraft so that aerodynamically they present few points of attack. In the opened state
5 of the valve, one flap shields the opening against any airflow flowing along the outside of the aircraft.

Generally, when valves of the initially mentioned type are opened a clearly discernible noise results due to the escaping air. This is why in the state of the art, various approaches can be found which attempt to reduce the noise.

10 For example, DE 103 13729 A1 suggests that a Laval nozzle is imitated by the shape of the flaps as the valve is opened. By these means the air exits from the valve at supersonic speed, and the sound is deflected away from the valve.

US 6,116,541 discloses that the leading edge of a second flap is configured with notches. Furthermore, a web extending in a direction which is transverse to the flow
15 direction of the escaping air is provided on the first flap, and has the purpose of slowing down the escaping air. In addition, on the fluidflow facing side of the edge, notches are provided to reduce noise.

Furthermore, WO 2005/023649 A1 discloses a valve of the initially mentioned type wherein notches that create eddies are formed in the edges of the valve flaps. It is
20 also disclosed that regions of the flaps are roughened to reduce the noise of the escaping air.

Some embodiments disclosed herein may reduce the noise of a valve of the initially mentioned type.

According to an aspect of the invention, there is provided an outflow valve for an
25 aircraft to control a fluid flow from a first environment to a second environment, comprising: a frame disposed in an area of an opening of a separating element which

29126-46

2a

- separates the first environment from the second environment; a first flap and a second flap for controlling the fluid flow through the opening between the first environment and the second environment, wherein the flaps are moveable within the frame, wherein the flaps have protrusions which create eddies in the fluid flow to
- 5 reduce noise wherein the protrusions protrude from surfaces on the flaps and into the fluid flow, wherein the protrusions are separate from each other and spaced with respect to each other, wherein the surface of the protrusions forms an upward ramp in the flow direction and wherein the protrusions are arranged spaced from a mutual contacting area of the flaps.
- 10 The approach according to some embodiments of the present invention ensures that the formation

29126-46

3

of disruptive noise is prevented by the irregular fluid flow caused by the protrusions. This is achieved by causing eddies to be created at the protrusions
5 due to their shape, which propagate in an expansive manner in the flow direction in the form of eddy plaits. Due to the expanding flow, the eddies overlap downstream and are thus mutually disruptive. This prevents the formation of regular or stationary eddies which would lead to increased noise.

Furthermore, it is advantageous that by changing the shape and configuration,
10 tion, the valve can be adapted to various applications, such as different flow velocities or fluids having various properties, without having to change the basic structure of the valve.

The first flap can advantageously have first protrusions having an outline, side surfaces and a top surface, preferably on an inner surface near an edge
15 adjacent to a flow cross-section through which fluid flows out. Exiting fluid first flows along the inner surface of the first flap before it exits through the flow cross-section.

The arrangement of the protrusions in the flow path of the fluid ensures that the protrusions can have their maximum effect.

20 In an advantageous embodiment, the first protrusions have an essentially triangular outline, wherein a corner point of the outline defines a tip and the two other corner points define a base of the outline. Such a triangular outline allows the pressure distribution of a fluid flow to be advantageously influenced and eddy plaits with an advantageous diameter to be created.

25 The top surface of the first protrusions can advantageously have a concave configuration. This allows the flow to be advantageously influenced.

The top surface of the first protrusions is advantageously formed as an upward ramp in the flow direction. By their rise in the flow direction it is ensured that the first protrusions gradually influence the fluid flow and no undesirable singularities are formed.

- 5 In a particularly advantageous embodiment, the surface of the first protrusions is formed as a section of a cylindrical surface, wherein the axis of the cylinder is essentially parallel to the bottom and normal to the flow direction.

An edge of the first protrusions can be formed as a flow break-away edge to specifically induce eddies.

- 10 Furthermore, the tip of the triangle forming the outline of the first protrusion advantageously faces the flow direction.

The length of the base of the first protrusion can have a ratio to a length of an edge extending from the tip to the base of the outline of the first protrusions of at least 0.5 and no more than 0.9, advantageously between 0.69 and 0.71.

- 15 The height of the first protrusions can have a ratio to a length of the edges extending from the tip to the base of the outline of the first protrusions of at least 0 and no more than 0.4, advantageously between 0.19 and 0.21.

- 20 The diameter of the cylinder defining the top surface of the first protrusions can have a ratio to a length of the edges extending from the tip to the base of the outline of the first protrusions of at least 2 and no more than 6, advantageously between 3.9 and 4.1.

The first protrusions can be arranged in rows extending transverse to the flow direction. By this configuration it is possible to influence the fluid flow across its entire width.

Furthermore, the first protrusions are advantageously arranged in staggered rows transverse to the flow direction. By these means, an interaction of the eddy plaits between the rows is encouraged.

5 Advantageously, the second flap has first protrusions on an outer surface in the vicinity of an edge adjacent to the flow cross-section. This ensures that the already flown out fluid, which flows along the separating element on the outer surface of the second flap, is influenced in a noise-reducing manner.

10 Furthermore, the second flap can have two protrusions, with an outline, side surfaces and a top surface, in the vicinity of an edge adjacent to the flow cross-section.

By these means it is ensured that fluid flowing along the inner surface of the second flap is conditioned prior to flowing out.

15 The second protrusions advantageously have an essentially trapezoidal outline, wherein a shorter side of the parallel sides of the outline defines a tip and a longer one of the parallel sides of the outline forms a base. This outline takes the flow conditions into account which are present in the places in which the second protrusions are arranged.

20 The top surface of the second protrusions is advantageously formed as an upward ramp in the flow direction. By these means, a discontinuity is avoided as the fluid flow impinges on the protrusions.

The top surface of the second protrusion is advantageously planar.

Furthermore, the tip of the second protrusions is preferably upstream of the base.

The edges forming the tip and the base of the second protrusions are advantageously arranged transverse to the flow direction. By these means, the influence of the second protrusions on the fluid flow can easily be determined.

5 The base of the second protrusions advantageously forms a flow break-away edge.

The length of the flow separation edge of the second protrusions can have a ratio to a length of the edges of the outline extending from the tip to the base of the second protrusions of at least 0.5 and no more than 0.9, preferably between 0.69 and 0.71.

10 The length of the base of the second protrusions can have a ratio to a length of the edges extending from the tip to the base of the outline of the second protrusions of at least 0.7 and no more than 1.1, advantageously between 0.89 and 0.91.

15 The length of the tip of the second protrusions can have a ratio to a length of the edges extending from the tip to the base of the outline of the second protrusions of at least 0 and no more than 0.4, advantageously between 0.09 and 0.11.

20 The height of the second protrusions can have a ratio to a length of the edges extending from the tip to the base of the outline of the second protrusions of at least 0.1 and no more than 0.5, advantageously between 0.29 and 0.31.

25 In an advantageous embodiment, the second protrusions are arranged in a row essentially transverse to the flow direction, which ensures that the fluid flow is influenced by the effect of the second protrusions across its entire width.

Advantageously, the number of the first protrusions exceeds the number of the second protrusions.

Furthermore, the second protrusions advantageously have a greater volume than the first protrusions, which ensures that the different flow conditions in the area of the first protrusions and the second protrusions is taken into consideration.

The bottom portion of the protrusions can be configured to have rounded corners. By these means, an eddy formation specifically in the center with respect to the height of the flow-through opening is achieved.

10 The edge adjacent to the flow cross-section of the second flap advantageously has a rounded configuration to obstruct the fluid flow as little as possible.

In a further preferred embodiment, two rows of first protrusions are arranged on each flap.

15 The invention will be explained in the following with reference to an exemplary embodiment illustrated in the accompanying drawings, in which:

Fig. 1 is a perspective view of an embodiment of the valve according to the present invention;

20 Fig. 2 is a sectional view along a flow direction of the first flap and the second flap;

Fig 3 shows the detail indicated as III in Fig. 2;

Fig. 4 is a perspective view along the fluid flow against the flaps in the open state;

Fig. 5 is an exemplary arrangement of protrusions on a flap;

Fig. 6 is a plan view of an embodiment of the first protrusions;

Fig. 7 is a cross section along line VII-VII of Fig. 6;

Fig. 8 is a plan view of an embodiment of the second protrusions; and

5 Fig. 9 is a cross sectional view along line IX-IX in Fig. 8.

Valve 10 shown in Fig. 1 is used as an outflow valve in an aircraft. Valve 10 has a frame 12, in which a first flap 14 and a second flap 16 are arranged. First flap 14 is larger than second flap 16. Furthermore, flaps 14, 16 are pivotably joined to frame 12 by means of bearings 18. Frame 12 of valve 10 is
10 inserted in an opening in the hull of an aircraft.

First flap 14 has a connecting portion 20, and second flap 16 has a connecting portion 22. The connecting portions 20, 22 are coupled by means of a linkage mechanism 24, which defines the position of first flap 14 relative to second flap 16.

15 Furthermore, second flap 16 has a control portion 23 which is connected to a drive (not shown) via a linkage mechanism to control the pivoting position of second flap 16. Since flaps 14, 16 are linked by means of linkage mechanism 24, the position of the two flaps and thus the opening cross section can be controlled by means of a single drive.

20 In the closed position, as shown in Fig. 2, flaps 14, 16 are in contact in a contacting area 26. By these means secure closing of valve 10 is ensured. First flap 14 has first protrusions 30 on its inner surface 28. Second flap 16 has second protrusions 34 on its inner surface 32 and first protrusions 38 on its outer surface 36. This arrangement is shown in detail in Fig. 3.

The edge area 40 of second flap 16 has a rounded configuration. Towards inner surface 32, second protrusions 34 are arranged immediately adjacent to edge area 40 and protrude from the planar surface of inner surface 32 so that they are immersed in airflow 42. First protrusions 38 are arranged at a distance to rounded edge area 40 towards outer surface 36.

Inner surface 28 of first flap 14 has a contacting area 46 adjacent to contacting area 26. In the area of contacting area 46, inner surface 28 extends parallel to outer surface 44 of first flap 14. A ramp area 48 is adjacent to contacting area 46 in which, at a distance to contacting area 46, first protrusions 30 are arranged in such a manner that they protrude into airflow 42.

Protrusions 30, 34, 38 are, as can be seen in Figs. 4 and 5, in rows 50, 52 transverse to the flow direction of airflow 42. Protrusions 30, 34, 38 are formed separate and spaced with respect to each other. Two rows 50, 52 each of first protrusions 30, 38 and a row of second protrusions 34 are provided. Protrusions 30 of a first row 50 are in a staggered configuration with respect to the protrusions of a second row 52 in the transverse direction 54.

Second protrusions 34 are formed in a row of three protrusions 34.

First protrusions 38 are arranged according to the same principle as first protrusions 30.

First protrusions 30 shown in Figs. 6 and 7 have a triangular outline 56. Airflow 52 flows over tip 58 to base 60. Top surface 62 of first protrusions 30 is configured concavely as a section from a cylindrical surface. Top surface 62 forms an upward ramp in the direction of airflow 42 and ends in a flow break-away edge 64 on the back surface 66 extending essentially vertically to the inner surface 28. At the foot of back surface 66, a rounded bottom portion 68 is formed.

The ratio of width b of base 60 to length l of the legs of outline 56 is 0.7. Furthermore, height h of flow break-away edge 64 is 0.2 times length l . The ratio of the diameter of the cylinder used for forming surface 62 to length l is 4.

5 First protrusions 38 are essentially formed like first protrusions 30. However, their forms are adapted to the flow environment of their arrangement. First protrusions 38 have no bottom portion 68, for example.

10 Second protrusions 34 have a pronounced bottom portion 74, as can be seen from Figs. 8 and 9. This is why width b_1 of flow break-away edge 76 and width b_2 of bases 78 of trapezoidal outline 70 of second protrusions 34 differ greatly. Top surface 72 has a planar configuration, in contrast to first protrusions 30, 38. Width b_1 of flow break-away edge 76 of second protrusions 34 is 0.7 times length l of outline 70. Width b_2 is 1.1 times length l and width b_3 of tip 80 is 0.1 times length l . Height h of flow break-away edge 76 is 0.3 times length l .

15 The shape of protrusions 30, 34, 38 with their high aspect ratio produces eddies. The interaction of eddy plaits created by protrusions 30, 34, 38 prevents the formation of uniform or stationary eddies which could lead to high noises.

20 If valve 10 is thus opened by first flap 14 and second flap 16 being opened, airflow 42 begins to flow as shown in Figs. 3 and 4. First protrusions 30, 38 and second protrusions 34 project into airflow 42 and cause the above-described effect.

25 It must be noted that the arrangement and form of the protrusions must be adapted to the respective framework conditions. The form and the arrangement of protrusions 30, 34, 38, in particular the form of the flaps, the pressure differential between inner surface 28, 32 and outer surface 36, 44 and the velocity of airflow 42 are critical for the construction of valve 10.

Flaps 14, 16 with protrusions 30, 34, 38 are thus made, for example, by milling from a solid aluminum block. This offers the possibility of fully automatic manufacture, such as on CNC milling machines. The person skilled in the art will know further methods, both manual and automatic, useful for their manufacture. The person skilled in the art will also know further suitable materials for use in valve 10.

Valve 10 together with frame 12 is inserted in an opening (not shown) of an aircraft shell. The position of flaps 14, 16 is used to control the amount of air that can escape from the cabin. In this way, the cabin interior pressure is controllable by means of varying the position of flaps 14. Protrusions 30, 34, 38 protruding into airflow 42 effect an intended influence on airflow 42 which leads to disruptive noise being minimized for the passengers of the aircraft.

List of Reference Numerals

10	valve	66	back surface
12	frame	68	bottom portion
14	first flap	70	outline
16	second flap	72	top surface
18	bearing	74	bottom portion
20	connecting portion	76	flow break-away edge
22	connecting portion	78	base
24	hydraulic element	80	tip
26	contacting area		
28	inner surface	b	width
30	first protrusions	b ₁	width
32	inner surface	b ₂	width
34	second protrusions	b ₃	width
36	outer surface	h	height
38	first protrusions	l	length
40	edge area		
42	airflow		
44	outer surface		
46	contacting area		
48	ramp area		
50	first row		
52	second row		
54	transverse direction		
56	outline		
58	tip		
60	base		
62	top surface		
64	flow break-away edge		

29126-46

13

CLAIMS:

1. An outflow valve for an aircraft to control a fluid flow from a first environment to a second environment, comprising:
 - 5 a frame disposed in an area of an opening of a separating element which separates the first environment from the second environment;
 - a first flap and a second flap for controlling the fluid flow through the opening between the first environment and the second environment, wherein the flaps are moveable within the frame,
 - 10 wherein the flaps have protrusions which create eddies in the fluid flow to reduce noise wherein the protrusions protrude from surfaces on the flaps and into the fluid flow, wherein the protrusions are separate from each other and spaced with respect to each other, wherein the surface of the protrusions forms an upward ramp in the flow direction and wherein the protrusions are arranged spaced from a mutual contacting area of the flaps.
- 15 2. The valve according to claim 1, wherein the first flap has first protrusions on an inner surface in the vicinity of an edge adjacent to a flow cross-section, and with an outline, side surfaces and a top surface.
3. The valve according to claim 2, wherein the top surface of the first protrusions have a concave configuration.
- 20 4. The valve according to claim 2 or claim 3, wherein the top surface of the first protrusions is formed as a section of a cylindrical surface, wherein the axis of the cylinder is essentially parallel to the outline and normal to the flow direction.
5. The valve according to any one of claims 2 to 4, wherein an edge of the first protrusions is formed as a flow breakaway edge.

29126-46

14

6. The valve according to claim 2, wherein the first protrusions have an essentially triangular outline, wherein a corner point of the outline defines a tip and the two other corner points define a base of the outline.

7. The valve according to claim 6, wherein the tip of a triangle forming the
5 outline of the first protrusions faces the flow direction.

8. The valve according to claim 6 or 7, wherein a length b of the base and a length l of the edges extending from the tip to the base of the outline of the first protrusions have a ratio b/l of at least 0.5 and no more than 0.9.

9. The valve according to claim 8, wherein the ratio b/l is between 0.69
10 and 0.71.

10. The valve according to any one of claims 6 to 9, wherein the height h of the first protrusions and the length l of the edges extending from the tip to the base of the outline of the first protrusions have a ratio h/l of at least 0 and no more than 0.5.

11. The valve according to claim 10, wherein the ratio h/l is between 0.19
15 and 0.21.

12. The valve according to claim 4, wherein the first protrusions have an essentially triangular outline, wherein a corner point of the outline defines a tip and the two other corner points define a base of the outline; and wherein the diameter of the cylinder that defines the top surface of the first protrusions and the length l of the
20 edges extending from the tip to the base of the outline of the first protrusions have a ratio of at least 2 and no more than 6.

13. The valve according to claim 12, wherein the ratio is between 3.9 and 4.1.

14. The valve according to any one of claims 2 to 13, wherein the first
25 protrusions are arranged in rows extending transverse to the flow direction.

29126-46

15

15. The valve according to claim 14, wherein the first protrusions are arranged in staggered rows transverse to the flow direction.

16. The valve according to any one of claims 1 to 15, wherein, the second flap has first protrusions on an outer surface in the vicinity of an edge adjacent to the
5 flow cross-section.

17. The valve according to any one of claims 1 to 16, wherein the second flap has second protrusions on an inner surface in the vicinity of an edge adjacent to the flow cross-section with an outline, side surfaces and a top surface.

18. The valve according to claim 17, wherein the second protrusions have
10 an essentially trapezoidal outline, wherein a shorter side of parallel sides of the outline define a tip and a longer one of the parallel sides of the outline define a base.

19. The valve according to any one of claims 17 to 18, wherein the top surface of the second protrusions has a planar configuration.

20. The valve according to any one of claims 17 to 19, wherein the tip of the
15 second protrusions is arranged upstream of the base.

21. The valve according to any one of claims 17 to 20, wherein the edges forming the tip and the base of the second protrusions are arranged essentially transverse to the flow direction.

22. The valve according to any one of claims 17 to 21, wherein a flow
20 break-away edge is formed in the vicinity of the base of the second protrusions.

23. The valve according to any one of claims 17 to 22, wherein the length b_1 of the flow break-away edge and the length l of the edges extending from the tip to the base of the outline of the second protrusions have a ratio b_1/l of at least 0.5 and no more than 0.9.

29126-46

16

24. The valve according to claim 23, wherein the ratio b_1/l is between 0.69 and 0.71
25. The valve according to any one of claims 17 to 24, wherein the length b_2 of the base and the length l of the edges extending from the tip to the base of the outline of the second protrusions have a ratio b_2/l of at least 0.7 and no more than 1.1.
26. The valve according to claim 25, wherein the ratio b_2/l is between 0.89 and 0.91.
27. The valve according to any one of claims 17 to 26, wherein the length b_3 of the tip and the length l of the edges extending from the tip to the base of the outline of the second protrusions have a ratio b_3/l of at least 0 and no more than 0.4.
28. The valve according to claim 27, wherein the ratio b_3/l is between 0.09 and 0.11.
29. The valve according to any one of claims 17 to 28, wherein the height h of the second protrusions and the length l of the edges extending from the tip to the base of the outline of the second protrusions have a ratio h/l of at least 0.1 and no more than 0.5.
30. The valve according to claim 29 wherein the ratio h/l is between 0.29 and 0.31.
31. The valve according to any one of claims 17 to 30, wherein the second protrusions are arranged in a row essentially transverse to the flow direction.
32. The valve according to any one of claims 17 to 31, wherein the number of first protrusions exceeds the number of the second protrusions.
33. The valve according to any one of claims 17 to 32, wherein the second protrusions have a larger volume than the first protrusions.

29126-46

17

34. The valve according to any one of claims 1 to 33, wherein the protrusions have bottom portions which provide rounded edges.

35. The valve according to any one of claims 1 to 34, wherein the edge area adjacent to the flow cross-section of the second flap has a rounded
5 configuration.

36. The valve according to any one of claims 1 to 35, wherein two rows of first protrusions are arranged on each of the flaps.

Fig. 1

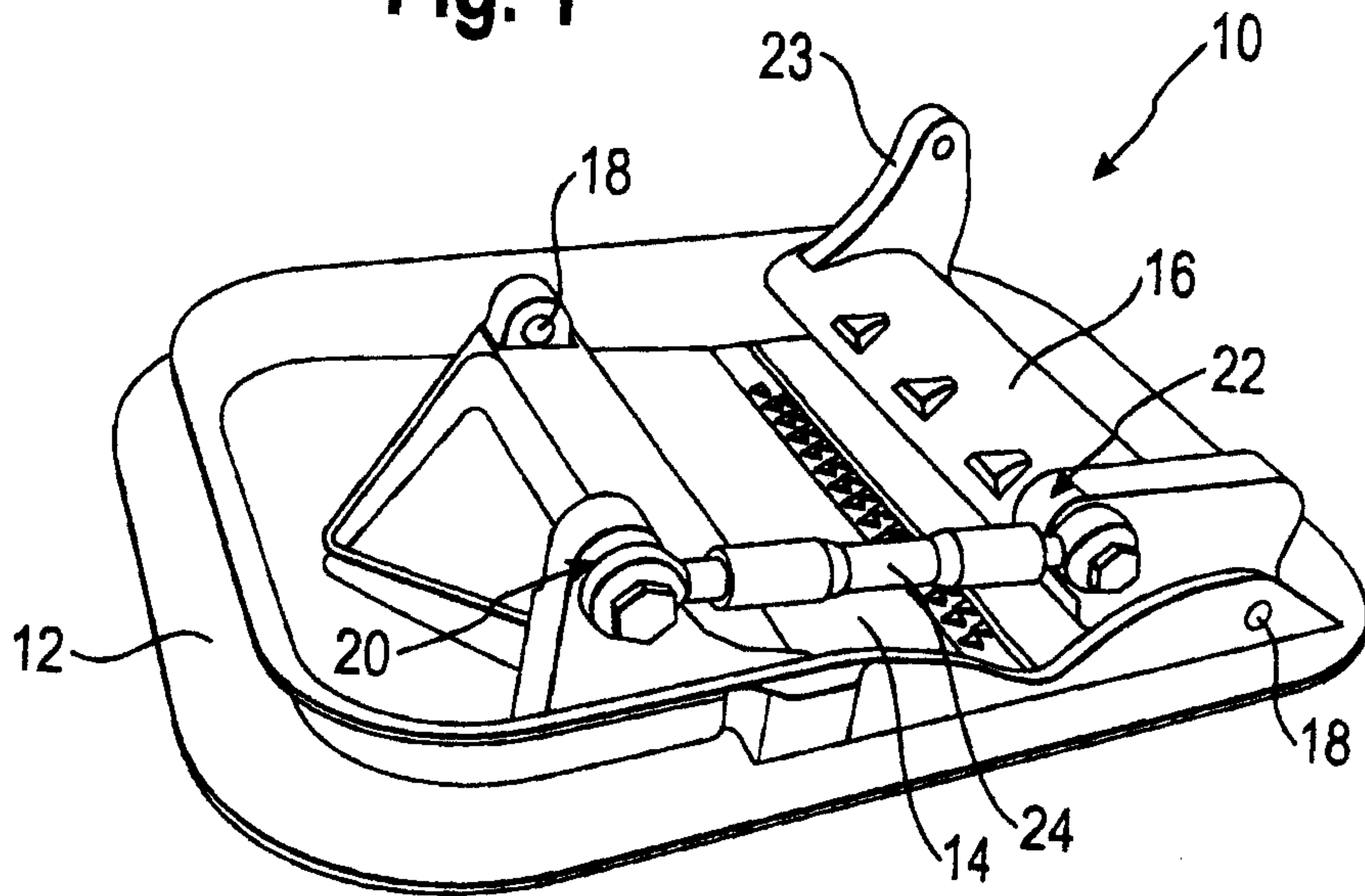
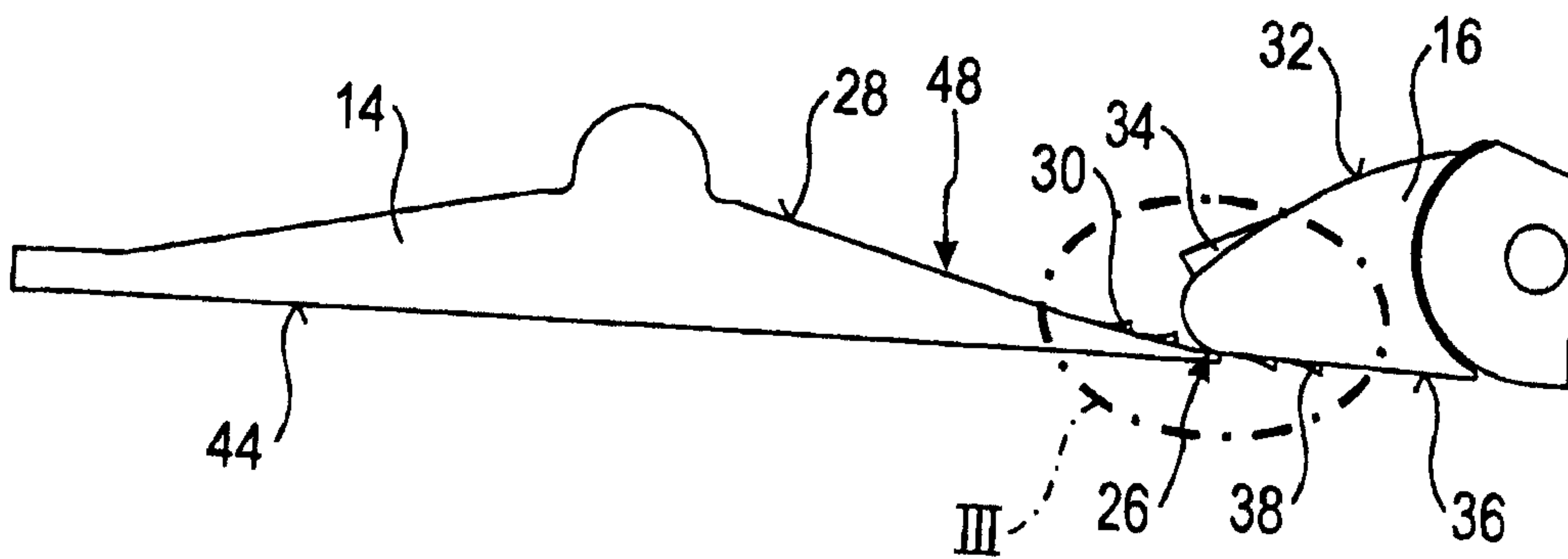
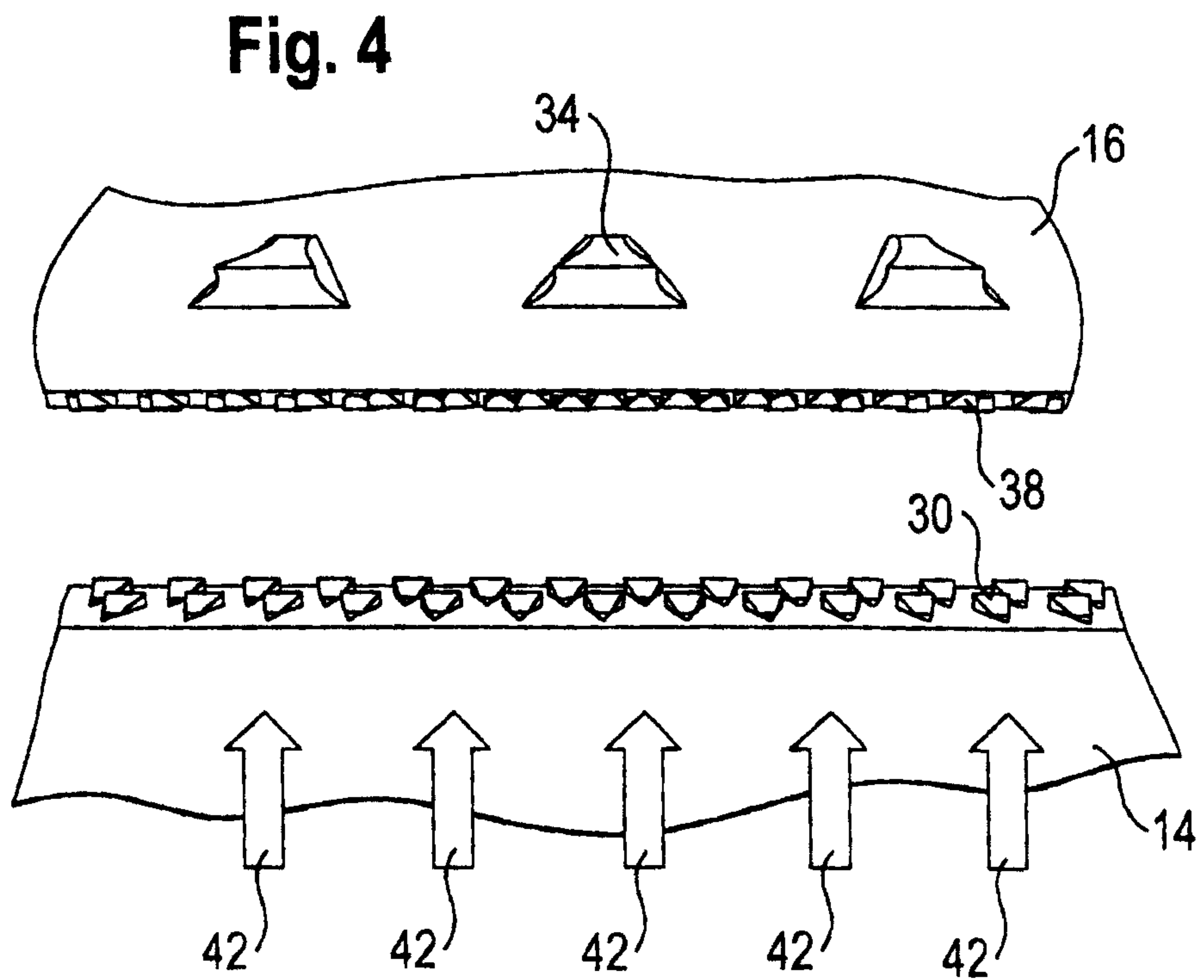
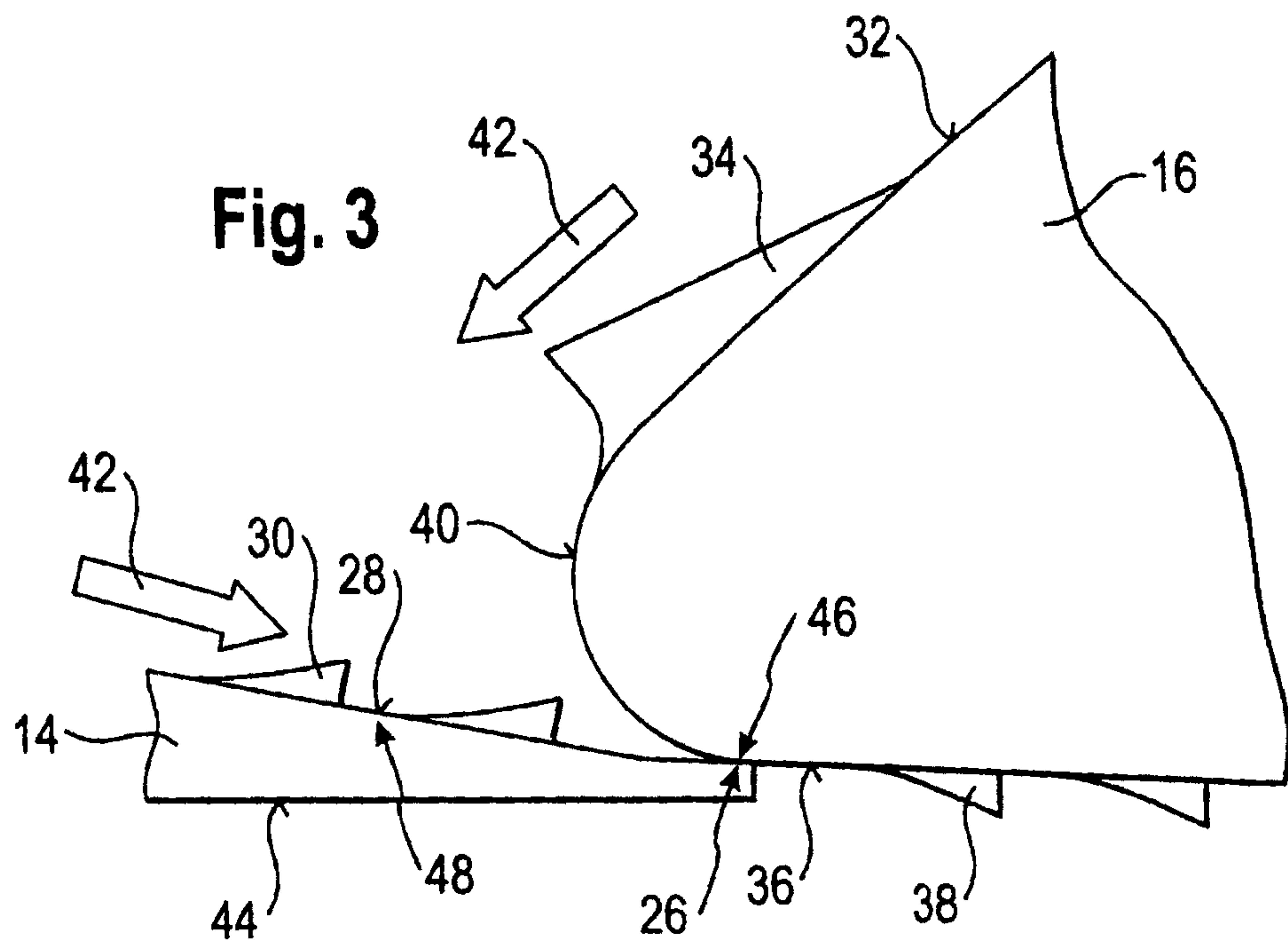

Fig. 2





3 / 4

Fig. 5

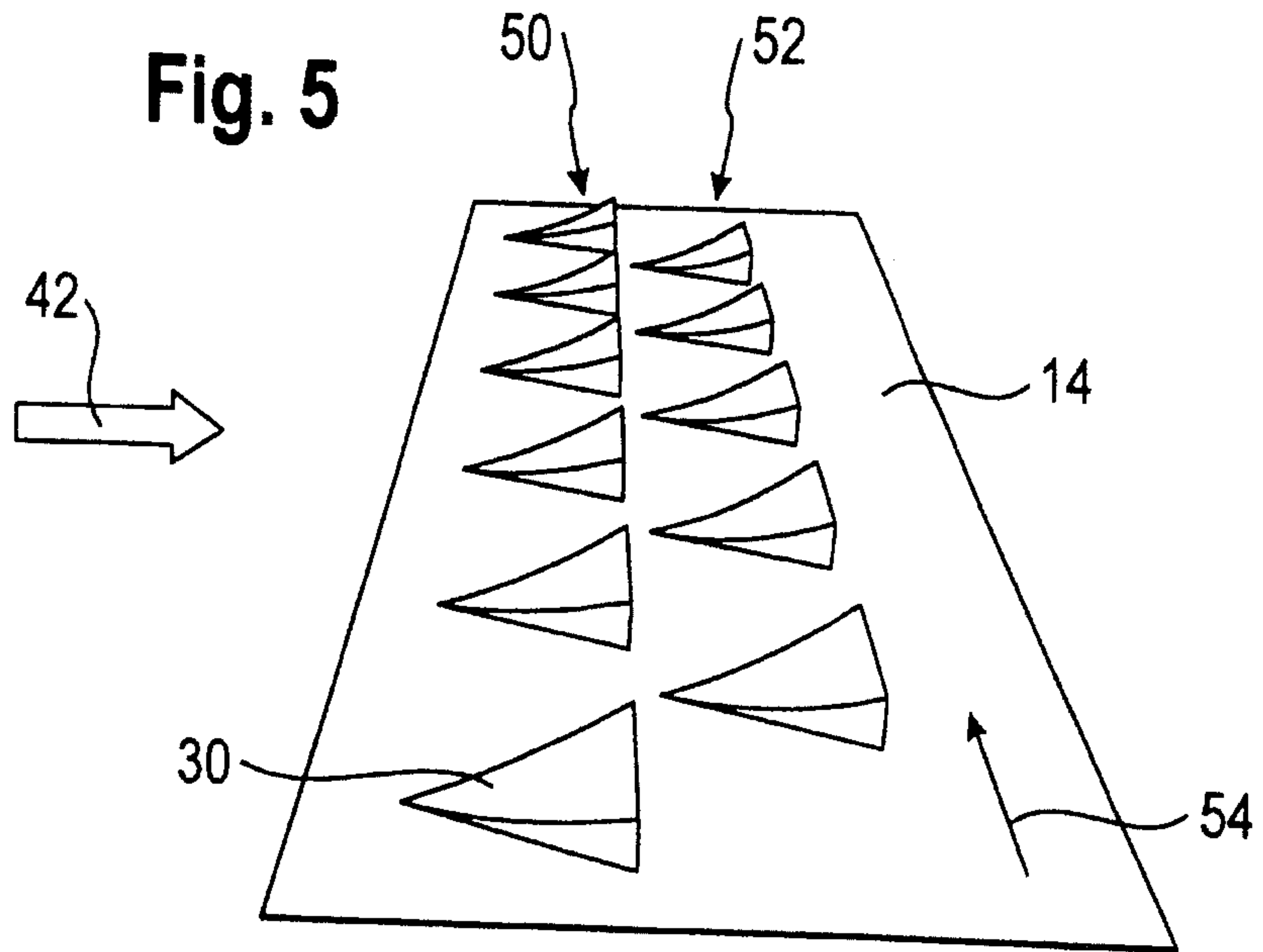

Fig. 6

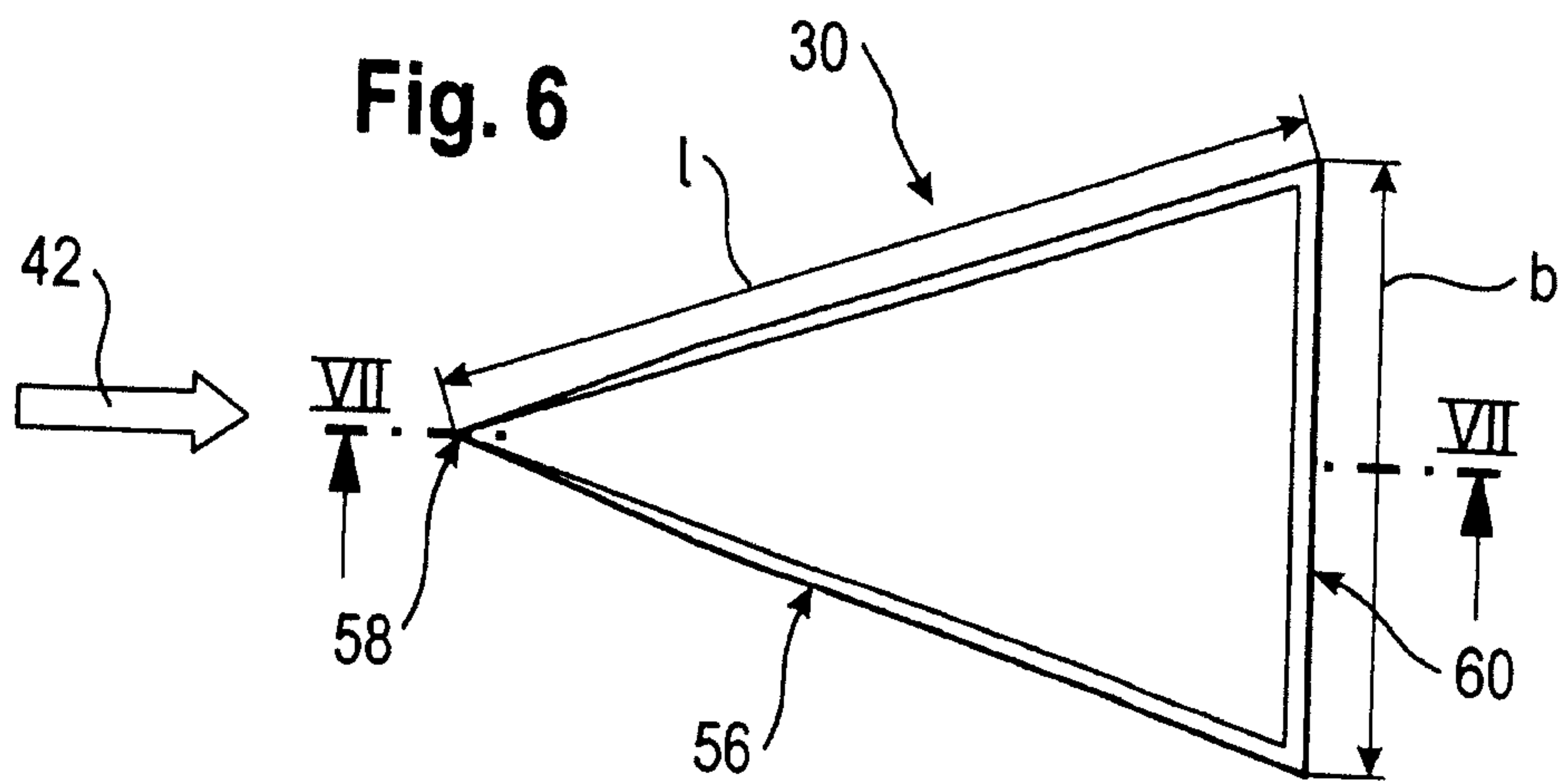

Fig. 7

