

H. PEARCE.

Grist Mill.

No. 1,266.

Patented July 29, 1839.

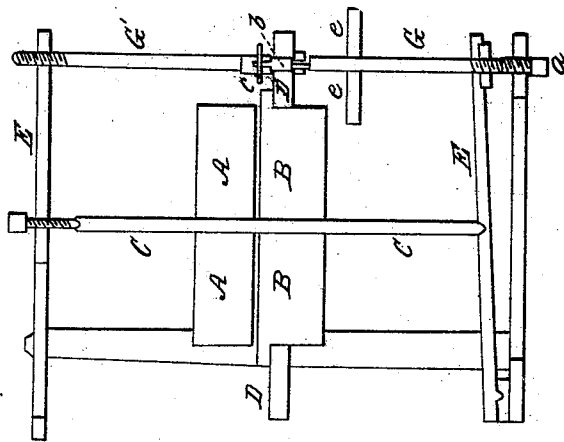
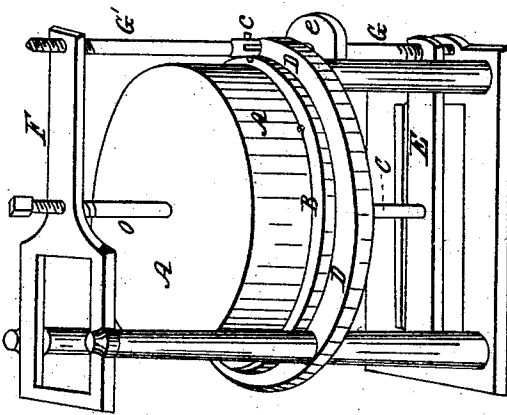

UNITED STATES PATENT OFFICE.

HENRY PEARCE, OF CINCINNATI, OHIO.

MILL FOR GRINDING GRAIN.

Specification of Letters Patent No. 1,266, dated July 29, 1839.

To all whom it may concern:

Be it known that I, HENRY PEARCE, of the city of Cincinnati, in the State of Ohio, have made an Improvement in the Machinery of Mills for the Manufacture of Grain into Meal and Flour, for which Letters Patent of the United States were obtained by Jessy O. Smith, under date of the 9th day of January, 1830; and I do hereby declare that the following is a full and exact description of my improvement on said machinery.

My improvement consists in the manner in which I construct the part which I denominate the pressure rod, which is intended to elevate the bridge tree, and, consequently, the running stone, and to regulate the action of the mill in this particular part. In other parts, my grist mill resembles such as have been previously in use, and which need not, therefore, be described by me.

The accompanying drawing represents a perspective view, and a vertical section of my machine through its center.

A, A, is the running, and B, B, the bed stone; the runner being attached to the spindle C, C, and the bed stone being held in the frame D, D, as in the mill upon which this is an improvement. E is the bridge tree, and F, the top frame, which are also similar to those in the original machine.

G, G, is the pressure rod.

a, is a regulating screw passing through the bottom of the frame of the mill, and bearing against the lower section of the pressure rod; which rod is divided into two parts, or sections, one of which extends up to the frame D, which contains the bed stone, and the other section extends from said frame, to the top frame F, through which it passes. The upper section G', has a collar piece *b*, attached to it on its lower end, which collar piece passes through the frame D, and has a square socket on its under side which receives the upper end of the lower section G, of the pressure rod, which is fitted into said socket, its end being squared, and serving as a coupling to cause both sections of the pressure rod to turn together. The collar piece *b*, is a separate piece from the two sections of the

pressure rod, serving to connect them together, there being a joint and pin at *c*, which unites the collar piece with the section G'; and by taking this pin out the top frame F, may be turned back, to raise the stone for dressing, or for any other purpose.

d, d, is the projecting head, or flanch, of the collar piece which bears against the under side of the frame D. The lower end of the section G, has a screw cut upon it, which works through the nut *d*, on the under side of the bridge tree E; and the upper end of the section G', screws through the end of the top frame F, the threads of both screws being similar.

e, e, is a wheel attached to the lower section of the pressure rod, and serving to turn it. The three pieces of which the pressure rod consists, are, by this arrangement, connected together and form one continuous rod, by means of which the pressure is regulated, the bridge tree and the top frame being simultaneously raised, or depressed, to an equal extent. The great advantage of this mode of constructing the pressure rod is that the stress produced from the tendency of the runner to rise is exerted directly upon the frame D, D, which contains the bed stone, and against which the flanch *d, d*, bears, instead of being exerted upon the bridge tree, as in the machine upon which this is an improvement; the operation of the stones is thus rendered more steady and certain than upon the former plan.

What I claim as my invention, and desire to secure by Letters Patent, is--

The within described manner of constructing the pressure rod with the flanch *d, d*, by means of which the stress resulting from the tendency of the runner to rise, is exerted directly upon the frame D, D, containing the bed stone, in consequence of the projecting flanch *d, d*, of the collar piece bearing against the lower side of the said frame, and its connection with the top frame, in the manner described.

HENRY PEARCE.

Witnesses:

THOS. P. JONES,
LINTON THORN.