

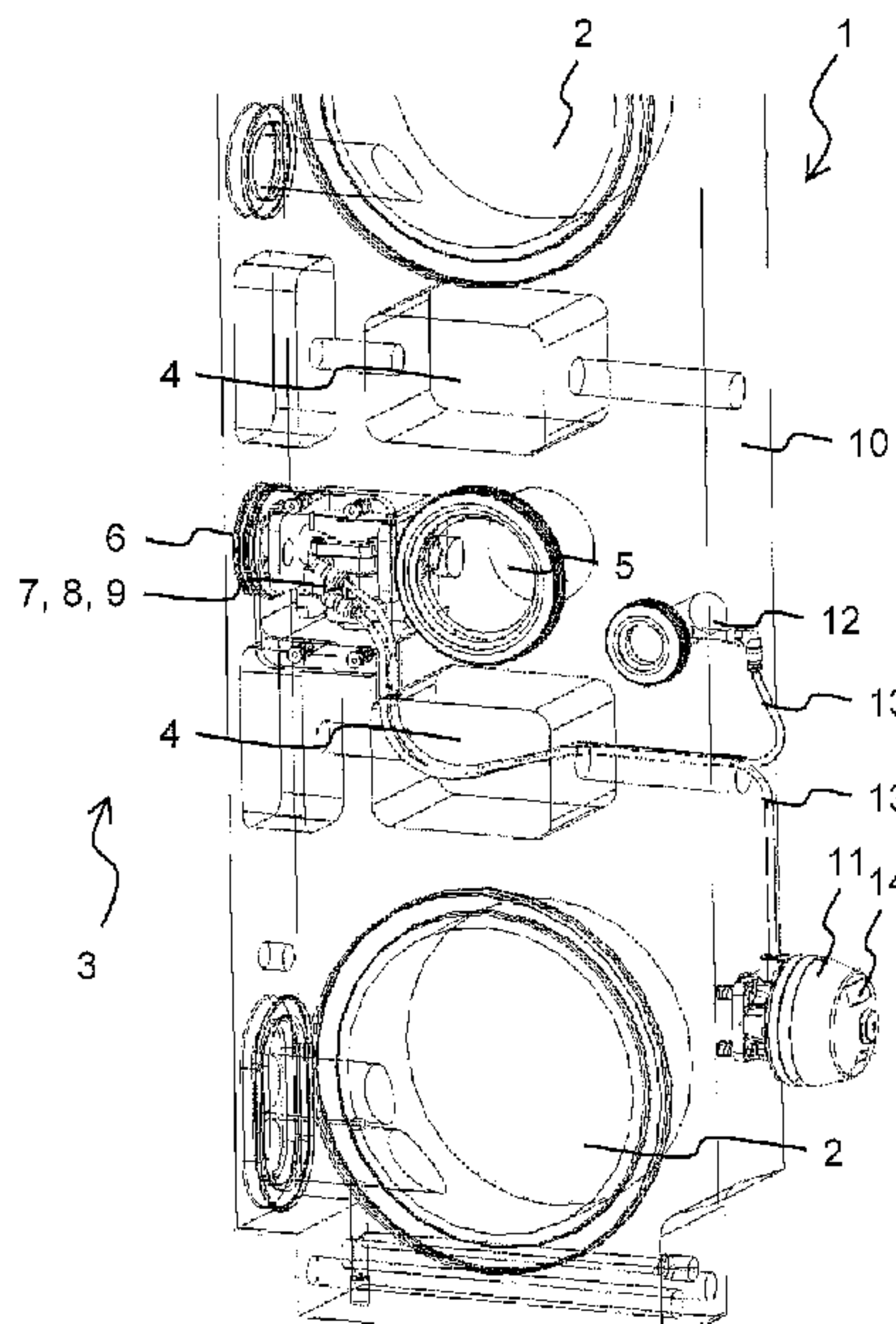

(86) Date de dépôt PCT/PCT Filing Date: 2012/10/25
 (87) Date publication PCT/PCT Publication Date: 2013/05/16
 (45) Date de délivrance/Issue Date: 2017/04/25
 (85) Entrée phase nationale/National Entry: 2014/05/01
 (86) N° demande PCT/PCT Application No.: EP 2012/071099
 (87) N° publication PCT/PCT Publication No.: 2013/068235
 (30) Priorité/Priority: 2011/11/10 (EP11188604.0)

(51) Cl.Int./Int.Cl. *B01D 25/12* (2006.01),
B01D 25/28 (2006.01), *B01D 35/143* (2006.01)
 (72) Inventeur/Inventor:
KILGUS, MICHAEL, DE
 (73) Propriétaire/Owner:
OUTOTEC OYJ, FI
 (74) Agent: MARKS & CLERK

(54) Titre : PLAQUE A CAVITE ET PROCEDE DE DETECTION D'UNE FUITE DE MEMBRANE
 (54) Title: RECESS PLATE AND METHOD FOR DETECTING MEMBRANE LEAKAGE



(57) **Abrégé/Abstract:**

The invention relates to a recess plate for a membrane filter device, the filter device having a stack of essentially identical recess plates, the recess plates having recesses, and the recesses forming filter chambers (3) between adjacent recess plates of the stack, into which filter chambers (3) a suspension can be supplied on a cake side of a filter cloth, and the suspension can permeate the filter cloth to a filtrate side thereof, such that a solid content of the suspension deposits on the filter cloth as a filter cake, each filter chamber (3) having a movable membrane, the membrane and the recess plate enclosing a squeezing chamber, the recess plate having an inlet duct (6) for inserting a pressurizing medium into the squeezing chamber, for mechanical pressing out of the respective filter cake. The invention further relates to a method for detecting membrane leakage in such membrane filter device. According to the invention it is suggested that, for each of the filter chambers (3) a shut-off valve (7) is provided for shutting the duct and a measuring device (8) for measuring pressure inside the squeezing chamber, and that the pressurizing medium is supplied into the respective squeezing chamber, after supplying the pressurizing medium the respective inlet duct (6) is tight closed, a pressure inside the squeezing chamber is monitored and detecting a decrease in the pressure is considered as evidence for a leakage of the respective membrane.

ABSTRACT

Provided is a recess plate for a membrane filter device and method for detecting membrane leakage in the device. The device having a stack of recess plates which have recesses which form filter chambers between adjacent recess plates, into which filter chambers a suspension can be supplied on a cake side of a filter cloth, and the suspension can permeate the cloth to a filtrate side thereof, such that a solid content of the suspension deposits on the cloth as a filter cake, each filter chamber having a movable membrane, the membrane and the recess plate enclosing a squeezing chamber, the recess plate having an inlet duct for inserting a pressurizing medium into the squeezing chamber, for mechanical pressing out of the respective filter cake. A shut-off valve is provided for each of the chambers for shutting the duct and a measuring device for measuring pressure inside the squeezing chamber.

TITLE OF INVENTION

Recess plate and Method for Detecting Membrane Leakage

TECHNICAL FIELD

5 The invention relates in general to filtering and in particular to a method for detecting membrane leakage and to a recess plate.

BACKGROUND ART

10 In a recess plate for a membrane filter device, the filter device has a stack of essentially identical recess plates, the recess plates having recesses, and the recesses forming filter chambers between adjacent recess plates of the stack, into which filter chambers a suspension can be supplied on a cake side of a filter cloth, and the suspension can permeate the filter cloth to a filtrate side thereof, such that a solid content of the suspension deposits on the filter cloth as a filter cake, each filter chamber having a movable membrane, the membrane and the recess plate enclosing a squeezing chamber, the recess plate having an inlet duct for inserting a pressurizing medium into the squeezing chamber, for mechanical
15 pressing out of the respective filter cake.

A filter device with a plurality of recess plates as plate stacks and filter chambers, which are respectively configured between adjacent recess plates of the stack, is known from US 4,844,803 A. In the filter chambers, substantially in the respective separation plane between the recess plate and the associated counter plate, one or two filter cloths and a
20 rubber elastic membrane are disposed depending on the configuration of the filter device. During filtering operation of the known filter device, the filter chambers are supplied through filling shoes with the pressurized suspension, which is to be filtered, and the suspension is pressed through the filter cloths. Thus, the solid content of the suspension is deposited on the filter cloth as a filter cake. The filtered suspension from which the solid
25 content is purged flows out from the filter chambers as a filtrate below the filter cloth substantially without pressure. After filtration, the one or two movable membranes are acted on by pressurized air or another gaseous medium at a gas pressure between 4 to 16 bar.

Whenever a leakage occurs in one of the membranes of the known filter device, the pressurizing medium percolates into the cake side and discharges unperceived from the filter device together with the filtrate. Where the leakage as such may easily be recognized by monitoring the fluid flow of the pressurizing medium supplied to the filter device, it is
5 merely impossible to identify the actually affected membrane, in particular where the filter device has a large number of filter chambers.

Methods and devices for detecting a leaking membrane are suggested in DE 299 16 427 U1 and in DE 203 07 912 U1: For each filter chamber, a fluid flow sensor is inserted into the duct for the pressurizing medium. In case the pressurizing medium still flows into a
10 chamber, where it has stopped flowing into the others, a leakage of the respective chamber and its membrane is detected.

During squeezing the filter cakes of the known filter devices, values of fluid flow of the pressurizing medium into the respective squeezing chambers spreads over a large interval due to decrease in pressure over the common feed pipe outside the filter chambers, due to
15 heterogeneous load of solid content inside the chambers or due to soiling of the respective ducts. Monitoring the fluid flows thus leads to false positive detection of leaking membranes or, more important, to missing actual leakages.

JP 10 296009 A discloses a device and method for the determination of leaks in membrane filter plates, relying on the determination of a leak flow. D1 suggests a shut-off valve by
20 means of which the pressure chamber can be closed so that no further pressure fluid can enter the chamber.

Thus it is an object of the invention to suggest another method and device for detecting a leaking membrane that avoids the drawbacks of the known state of the art.

25 SUMMARY OF INVENTION

In certain embodiments of the present invention, it is provided that for each of the filter chambers supplying the pressurizing medium into the respective squeezing chamber, after supplying the pressurizing medium closing tight the respective inlet duct, monitoring a

pressure inside the squeezing chamber and considering a decrease detected in the pressure as evidence for a leakage of the respective membrane. After shutting the duct and monitoring the pressure of the pressurizing medium inside the squeezing chamber rather than its fluid flow, a decreasing pressure indicates leakage of a respective chamber and its
5 membrane.

According to an aspect of the invention, there is provided a method of detecting membrane leakage in a membrane filter device, the filter device having a stack of substantially identical recess plates, the recess plates having recesses, and the recesses forming filter
10 chambers between adjacent recess plates of the stack, into which filter chambers a suspension can be supplied on a cake side of a filter cloth, and the suspension can permeate the filter cloth to a filtrate side thereof, such that a solid content of the suspension deposits on the filter cloth as a filter cake, each filter chamber having a movable membrane, the membrane and the corresponding recess plate enclosing a squeezing chamber, the recess
15 plate having an inlet duct for inserting a pressurizing medium into the squeezing chamber, for mechanical pressing out of the respective filter cake, the method comprising:

for each of the filter chambers supplying the pressurizing medium into the respective squeezing chamber;
after supplying the pressurizing medium closing tight the respective inlet duct;
20 monitoring a pressure inside the respective squeezing chamber; and
detecting a decrease in the pressure is considered as evidence of a leakage of the respective membrane.

According to another aspect of the invention, there is provided a recess plate for a
25 membrane filter device, the filter device having a stack of substantially identical recess plates, the recess plates having recesses, and the recesses forming filter chambers between adjacent recess plates of the stack, into which filter chambers a suspension can be supplied on a cake side of a filter cloth, and the suspension can permeate the filter cloth to a filtrate side thereof, such that a solid content of the suspension deposits on the filter cloth as a filter
30 cake, each filter chamber having a movable membrane, the membrane and the respective recess plate enclosing a squeezing chamber, the recess plate having an inlet duct for supplying a pressurizing medium into the squeezing chamber, for mechanical pressing out of the respective filter cake, the recess plate comprising a shut-off valve for shutting the duct and a measuring device for measuring pressure inside the squeezing chamber.

3a

The method according to the invention may equally be applied in filter devices having one or two filter clothes per filter chamber as well as in filter devices using gaseous or fluid pressurizing media. In particular, water, palm oil or acid sulfur may equally be applied as pressurizing media. The method according to the invention may further equally be applied
5 separate from a filtering process, in an empty state of the filter chambers, or it may be applied while squeezing out the filter cake after the filtering process.

Currently, squeezing pressure (and pressure for detecting membrane leakage) is known to be applicable from 4 up to 30 bar. However, even higher pressure may be applied with future filter devices. In particular, high squeezing pressure is applied in filter devices
10 having the membranes welded to the recess plates. Filter devices having replaceable membranes clamped or screwed to the recess plates are usually charged with lower squeezing pressures.

Preferably, within a method according to the invention, the membrane leakage is detected in case the pressure decreases at a rate exceeding a fixed value. As the squeezing chambers
15 can easily be pressurized to a common level, a common maximum rate of decrease in pressure can be defined for all squeezing chambers. This common fixed value greatly simplifies adjusting the related measuring, indicating and signal devices.

Further preferred, the value is fixed by statistical analysis of pressure data from monitoring a multitude of the squeezing chambers. Monitoring multiple squeezing chambers and
20 statistical analysis provides for automatic setting of the value. The fixed value may further be set by use of an expert system based on previously monitored pressure data.

Based on the recess plates described supra the object is achieved by providing a shut-off valve for shutting the duct and a measuring device for measuring pressure inside the

squeezing chamber. Such recess plate allows execution of a method according to the invention and features the advantages of the method mentioned above.

Preferably, within the recess plate according to the invention, the measuring device is arranged in the duct. In the duct, the measuring device is not exposed to the suspension,
5 thus avoiding the measuring device to be soiled and shortened in function.

Furthermore preferred, the measuring device is integrated with the shut-off valve. Integration of the shut-off valve with the measuring device provides for easy retrofitting and quick replacement of the common item.

In an advantageous embodiment of a recess plate according to the invention, a indicator for
10 indicating the pressure inside the squeezing chamber is provided, the indicator being visible while the recess plate being mounted into the stack. Such indicator provides for easy reading pressure data measured inside the squeezing chamber from outside the filter device.

In a further advantageous embodiment of a recess plate according to the invention, a signal
15 device for signaling a membrane leakage, in case the measuring device measures a decrease of the pressure. Such signal device provides for quick visual selection of a recess plate having a leaking membrane. The signal device may e.g. have an acoustic element or show a signal color or warning light for signaling leakage.

Further preferred, a recess plate according to the invention has a transmission element for
20 transmitting pressure data measured by the measuring device to a common pressure monitoring device of the filter device. Such transmission element and common monitoring device provides for automatic monitoring for membrane leakage as well as for keeping records and statistical analysis of pressure data for quality control.

BEST MODE FOR CARRYING OUT THE INVENTION

The method according to the invention and the associated device are subsequently described in more detail with reference to preferred embodiments illustrated in the following drawings:

5 Figure 1 shows the attachment part of a recess plate (not shown) according to the invention; and

 Figure 2 shows a detailed view of a section of the attachment part:

10 In the attachment part 1, the recess plate has two filtrate channels 2, forming two filtrate pipes together with filtrate channels of further such recess plates inside a stack of recess plates in a filter device. Through the filtrate pipe, the filtrate is discharged from a filter chamber 3, formed between the recess plate and an adjacent recess plate of the stack (filtrate pipe, further recess plates, stack and filter device not shown).

15 The attachment part 1 is connected to a main part of the recess plate by screws (main part and screws not shown) guided by through-holes 4 formed in the attachment part 1. The recess plate is split into main part and attachment parts 1 at two sides in order to overcome a restriction in size defined by common moulding presses used for manufacturing recess plates. Of course, the invention is not restricted to recess plates assembled from main parts and attachment parts, but may also be applied with recess plates moulded in one.

20 Further in the attachment part 1, the recess plate has one pressurizing channel 5, forming a pressurizing pipe together with pressurizing channels 5 of the further recess plates (pressurizing pipe not shown). Through the pressurizing pipe and an inlet duct 6, the pressurizing medium is supplied into the squeezing chamber (not shown).

25 The filtrate pipes, the pressurizing pipe as well as suspension channels (not shown) of the filter device are each formed by corresponding channels (namely the filtrate channels 2, the pressurizing channels 5 and further suspension channels, the latter not shown) are shaped into the attachment part 1 and into another attachment part (not shown) at the opposite side of the recess plate. The filtrate pipes, pressurizing pipes and suspension channels are thus
30 in existence only while the recess plates are stacked and interrupted while the recess plates are separated e.g. for discharging the filter cake from the filter chambers 3.

The recess plate has a shut-off valve 7 for shutting the inlet duct 6 as well as a measuring device 8 for measuring a pressure inside the squeezing chamber. The shut-off valve 7 and

the measuring device 8 are integrated into one valve cartridge 9 that is provided as in integral spare or retrofitting part for the recess plate. At its outer visible edge 10, the recess plate has a signal device 11 for signaling a membrane leakage. Both the valve cartridge 9 and the signal device 11 are driven by pressurized air, supplied through a separate control channel 12, forming a control pipe (not shown) and flexible tubes 13.

For checking for possible membrane leakages, prior to operation with the suspension, the squeezing chambers of the stacked recess plates are automatically supplied with compressed air as pressurizing medium through the pressurizing pipe. After pressure inside the pressurizing channel 5 reaches a steady state, pressurized air is supplied to the valve cartridges 9 through the control pipe for closing the shut-off valves 7.

The signal device 11 is connected to the squeezing chamber and exposed to the pressure inside the squeezing chamber. While exposed to the pressure supplied from the pressurizing pipe, a display 14 shows a green signal. Where the pressure decreases below a fixed critical value, the display 14 switches from green to red and the signal device 11 emits an audible beep for signaling leakage of the membrane.

In the figures

- 1 attachment part
- 2 filtrate channels
- 3 filter chamber
- 4 through-hole
- 5 pressurizing channel
- 6 inlet duct
- 7 shut-off valve
- 8 measuring device
- 9 valve cartridge
- 10 edge
- 11 signal device
- 12 control channel
- 13 tube
- 14 display

The embodiments of the invention in which an exclusive property or privilege is claimed are defined as follows:

1. A method of detecting membrane leakage in a membrane filter device, the filter device having a stack of substantially identical recess plates, the recess plates having recesses, and the recesses forming filter chambers between adjacent recess plates of the stack, into which filter chambers a suspension can be supplied on a cake side of a filter cloth, and the suspension can permeate the filter cloth to a filtrate side thereof, such that a solid content of the suspension deposits on the filter cloth as a filter cake, each filter chamber having a movable membrane, the membrane and the corresponding recess plate enclosing a squeezing chamber, the recess plate having an inlet duct for inserting a pressurizing medium into the squeezing chamber, for mechanical pressing out of the respective filter cake, the method comprising:

for each of the filter chambers supplying the pressurizing medium into the respective squeezing chamber;

after supplying the pressurizing medium closing tight the respective inlet duct;

monitoring a pressure inside the respective squeezing chamber; and

detecting a decrease in the pressure is considered as evidence of a leakage of the respective membrane.

2. The method according to claim 1, wherein the membrane leakage is detected when the pressure decreases at a rate exceeding a fixed value.

3. The method according to claim 2, wherein the value is fixed by statistical analysis of pressure data from monitoring a multitude of the squeezing chambers.

4. A recess plate for a membrane filter device, the filter device having a stack of substantially identical recess plates, the recess plates having recesses, and the recesses forming filter chambers between adjacent recess plates of the stack, into which filter chambers a suspension can be supplied on a cake side of a filter cloth, and the suspension can permeate the filter cloth to a filtrate side thereof, such that a solid content of the suspension deposits on the filter cloth as a filter cake, each filter chamber having a

movable membrane, the membrane and the respective recess plate enclosing a squeezing chamber, the recess plate having an inlet duct for supplying a pressurizing medium into the squeezing chamber, for mechanical pressing out of the respective filter cake, the recess plate comprising a shut-off valve for shutting the duct and a measuring device for measuring pressure inside the squeezing chamber.

5. The recess plate according to claim 4, wherein the measuring device is arranged in the inlet duct.
6. The recess plate according to claim 5, wherein the measuring device is integrated with the shut-off valve.
7. The recess plate according to any one of claims 4 to 6, wherein an indicator for indicating the pressure inside the squeezing chamber is provided, and wherein the indicator is visible while the respective recess plate is mounted into the stack.
8. The recess plate according to any one of claims 4 to 7, wherein a signal device for signaling a membrane leakage is provided when the measuring device measures a decrease of the pressure.
9. The recess plate according to claim 8, wherein the signal device has an acoustic element for signaling the leakage.
10. The recess plate according to any one of claims 4 to 9, wherein a transmission element is provided for transmitting pressure data measured by the measuring device to a common pressure monitoring device of the filter device.

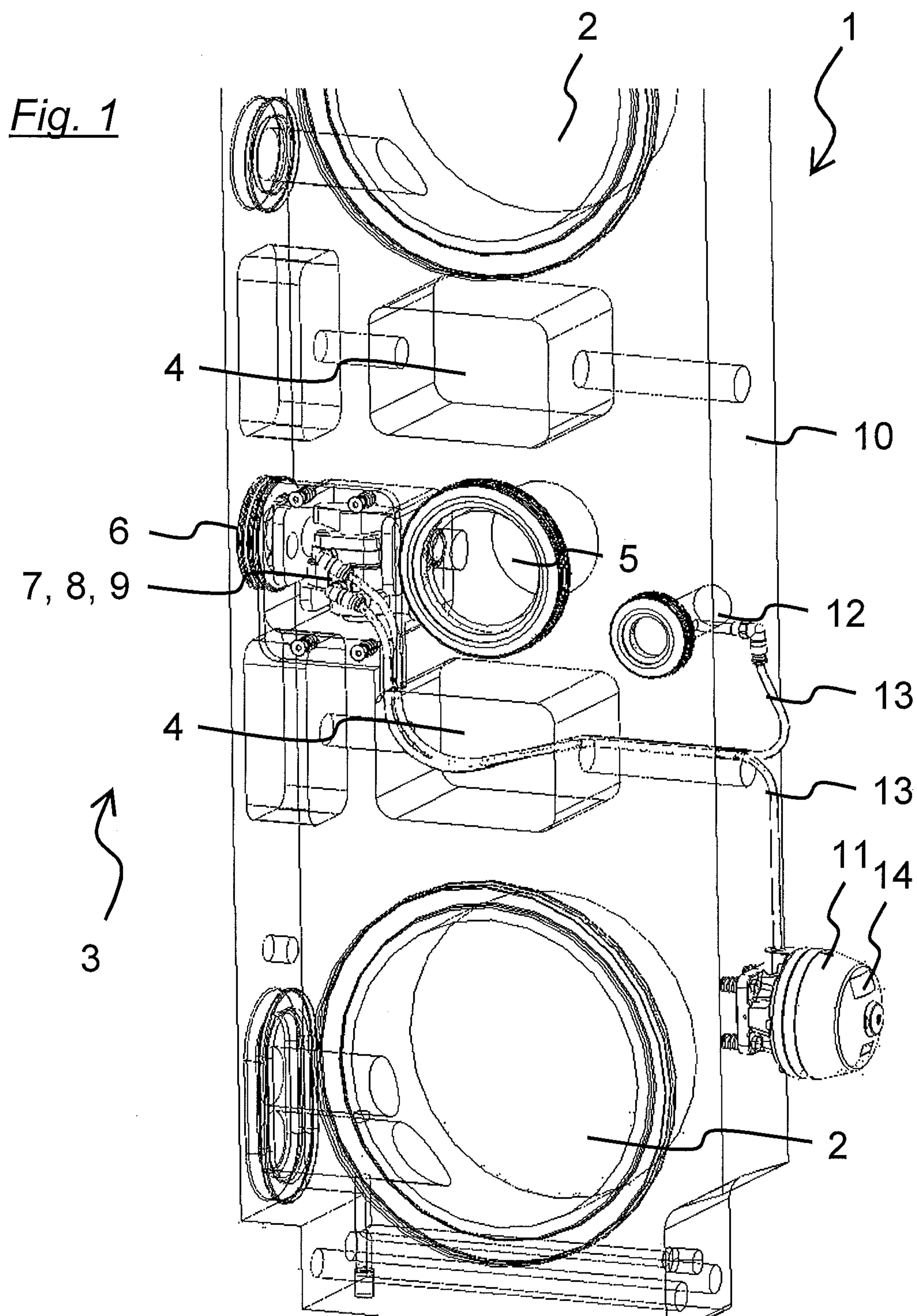

Fig. 2

