

June 22, 1937.

G. N. OGLOBLINSKY

2,084,700

TELEVISION SYSTEM

Filed Jan. 3, 1933

2 Sheets-Sheet 1

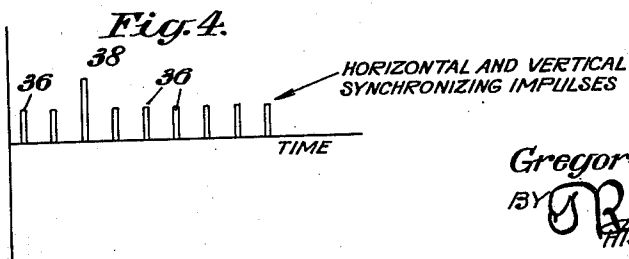
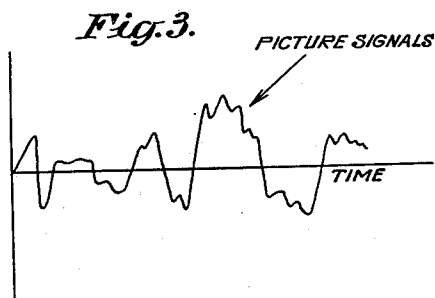
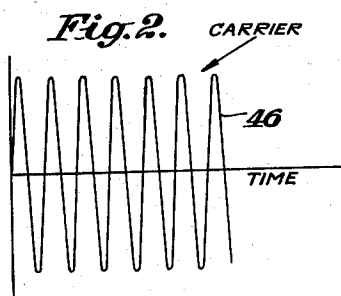
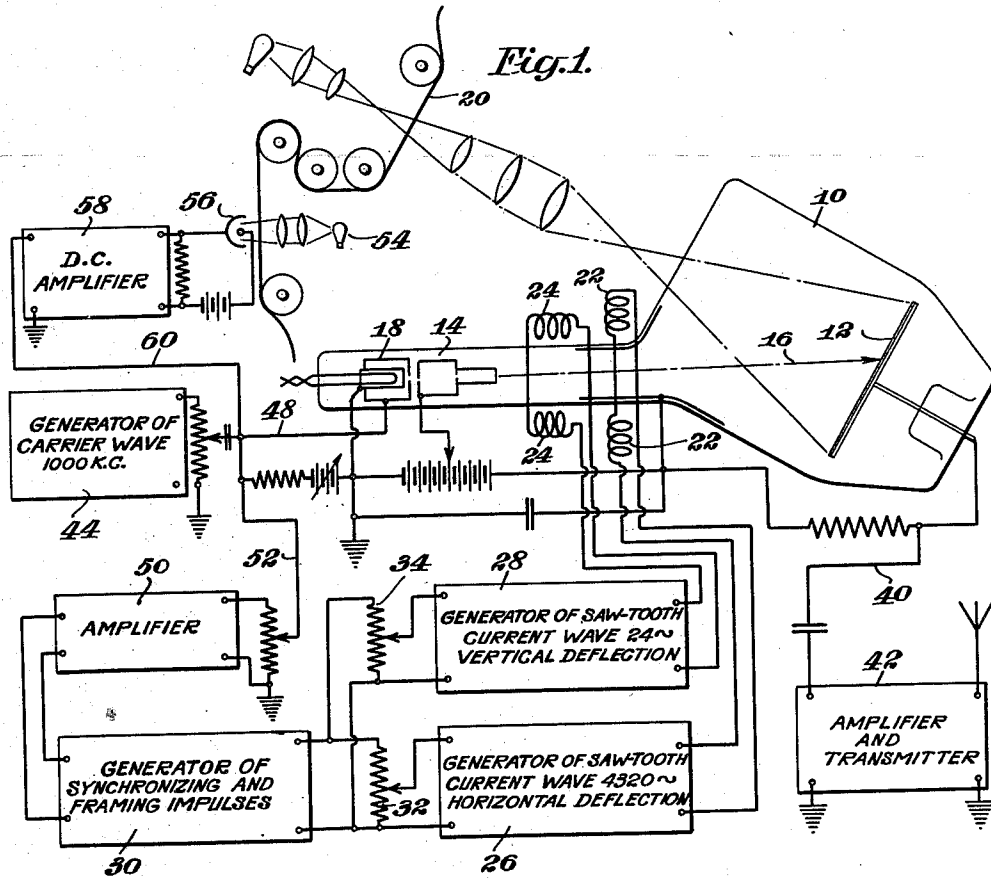

INVENTOR:
Gregory N. Ogloblinsky.
BY *[Signature]*
HIS ATTORNEY.

June 22, 1937.

G. N. OGLOBLINSKY

2,084,700

TELEVISION SYSTEM

Filed Jan. 3, 1933

2 Sheets-Sheet 2

Fig. 5.

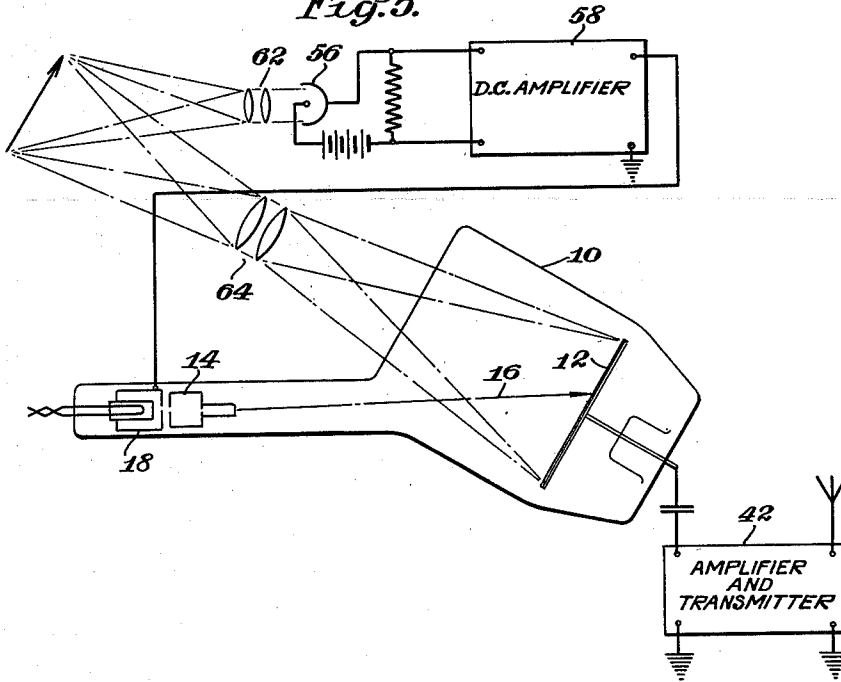
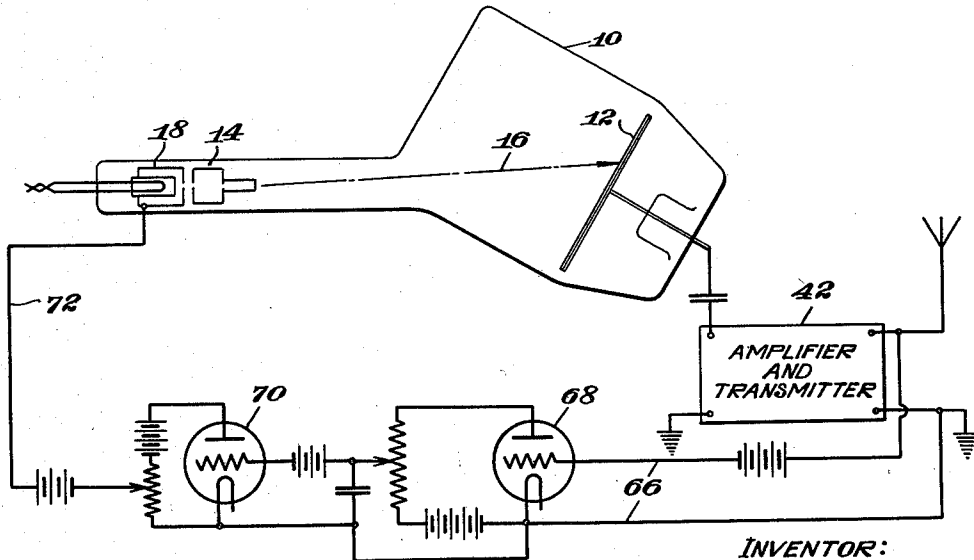

Fig. 6.



INVENTOR:
Gregory N. Ogloblinsky,
BY *J. R. Goldsborough*
HIS ATTORNEY.

UNITED STATES PATENT OFFICE

2,084,700

TELEVISION SYSTEM

Gregory N. Ogloblinsky, Collingswood, N. J., assignor to Radio Corporation of America, New York, N. Y., a corporation of Delaware

Application January 3, 1933, Serial No. 649,764

18 Claims. (Cl. 178—6)

My invention relates to improvements in television systems.

In television transmission it has been found to be advantageous to maintain the level of the picture signals substantially constant. This results in more efficient operation. Furthermore, in some systems it is required that the picture signals developed be transmitted on a carrier wave, and that synchronizing impulses be transmitted with the picture signals for utilization at the receiving station.

Various ways have been proposed for causing the desired operating actions referred to, and these vary widely in their construction and manner of operation, dependent upon the particular type of transmitting apparatus to be used.

One of the objects of my invention is to provide an improved television transmission system which embodies a well known form of cathode ray tube construction for developing the picture signals, and which operates in a simple manner to obtain the various advantages and the required operating actions referred to.

Other objects and advantages will hereinafter appear.

In accordance with my invention, a cathode ray tube is utilized for developing the picture signals. This tube is provided with a mosaic screen structure comprising a great number of minute photosensitive metallic elements disposed on one side of a supporting plate and insulated from the latter and from each other. An electron gun, provided with a control electrode for effecting variation of intensity of the ray, operates to develop a ray of electrons and to direct the same at the screen structure. An image of the object, which may be a moving picture film or a studio or outdoor scene, is projected onto the screen to develop individual electrostatic charges over the surface thereof, the amount of charge developed at any spot depending upon the light on the corresponding spot of the object or view.

The ray of electrons is deflected to scan an area of the screen, and this action operates to develop the picture signals by successively neutralizing the individual electrostatic charges referred to.

The fact that the level of the picture signals varies directly with variation in intensity of the scanning ray, is utilized in obtaining the desired operating actions.

For the purpose of maintaining the level of the picture signals substantially constant, an electrical effect is developed which varies in accordance with occurring variations in conditions of light

intensity over the effective surface portion of the screen structure which is scanned, and this effect is applied to the control grid to vary the ray intensity in a corresponding manner.

The carrier wave, on which the signals are transmitted, is developed within the tube itself by applying a suitable carrier wave to the control grid of the electron gun. In like manner, the synchronizing impulses required are generated at the transmitting station and applied to the control grid of the electron gun. In this manner, the ray intensity in the transmitting tube is made to vary so that the same synchronizing impulses are developed again within the transmitting tube for transmission on the carrier wave with the picture signals.

My invention resides in the improved system and method of operation of the character hereinafter described and claimed.

For the purpose of illustrating my invention, an embodiment thereof is shown in the drawings, wherein

Figure 1 is a simplified, diagrammatic view of a television transmission system embodying and operating in accordance with my invention;

Figs. 2, 3 and 4 are graphical views, illustrative of the manner of operation in Fig. 1; and

Figs. 5 and 6 are views similar to Fig. 1, showing several modifications.

In Fig. 1, the reference numeral 10 designates a cathode ray transmitting tube. The tube is provided with suitable mosaic photosensitive screen structure 12 and with a suitable electron gun 14 for developing a ray 16 of electrons and directing the ray at the screen structure. The gun 14 is provided with a control electrode or grid 18 which is effective to vary the intensity of the electron stream or ray directly proportionally to the voltage applied thereto. The individual parts of the gun 14 are supplied with suitable operating potentials, as shown.

In operation, the object, shown as being in the form of a moving picture film 20, is disposed as shown, and is given an intermittent movement by suitable mechanism whereby an image of each frame is projected onto the screen 12. The ray 16 is deflected to cause the same to scan the screen 12 horizontally by electromagnetic coils 22 and vertically by electromagnetic coils 24.

Assuming that the film 20 is moved intermittently at the rate of 24 pictures a second, and that the screen 12 is to be scanned horizontally along 180 lines during each picture or frame, the correct deflection of the ray for these conditions is obtained by employing a generator 26 for

supplying to the coils 22 a saw-tooth current wave of 4320 cycles, and by employing a generator 28 for supplying to the coils 24 a saw-tooth current wave of 24 cycles. These generators are driven or maintained in operation at these frequencies by employing a suitable generator 30 which develops in the resistances 32 and 34 horizontal synchronizing impulses which occur at the rate of 4320 cycles a second, and framing impulses which occur at the rate of 24 a second, as shown at 36 and 38, respectively, in Fig. 4.

The picture signals developed appear in the connection 40, and are amplified and transmitted by suitable apparatus designated generally by the reference numeral 42.

A suitable generator 44 generates an electrical wave at carrier frequency, designated 46 in Fig. 2, and this wave is applied to the control electrode 18 by a connection 48. The ray intensity, therefore, is varied in a corresponding manner to develop within the tube 10 and in the connection 40 a carrier wave on which the picture signals are transmitted.

In a like manner, the synchronizing and framing impulses 36 and 38 are amplified by a suitable amplifier 50 and applied to the control grid 18 by a connection 52. In this manner, the intensity of the ray 16 is increased 4320 times a second and at the end of each horizontal scanning line, to develop within the tube 10 impulses corresponding to the impulses 36 and which are transmitted on the carrier wave with the picture signals. Also, the intensity of the ray 16 is increased by the framing impulses 38 to a level substantially higher than the level to which the ray intensity is increased by the impulses 36. Since the impulses 38 occur twenty-four times a second, that is, at the framing frequency, similar impulses are developed within the tube 10 and transmitted on the carrier wave 46 with the picture signals.

For the purpose of automatically maintaining the level of the picture signals substantially constant, the film 20 is caused to pass between a source of light 54 and a photoelectric cell 56. In this manner, an electrical effect is developed which varies in accordance with occurring variations in conditions of average light-intensity over the effective portion of the screen 12. That is, as the average light-intensity varies, due either to difference in the pictures or variations in thickness of the film, the electrical effect developed varies in a corresponding manner. This electrical effect is amplified in a suitable amplifier 58 and applied by a connection 60 to the control grid 18. The polarity in the output circuit of the amplifier 58 is such that as the average light intensity on the screen 12 increases, the bias on the grid 18 is made more negative, and vice versa. In this manner, the intensity of the ray 16 is varied automatically in accordance with and inversely proportionally to occurring variations in conditions of average light-intensity over the individual pictures of the film 20.

Fig. 5 illustrates an embodiment of my invention for transmission of an outdoor view. In such case, it is proposed to mount the photocell 56 and the associated amplifier 58 in the same casing with the tube 10, and to utilize a lens system 62 for projecting onto the photocell an image of the view. A suitable lens system 64 is employed to project onto the screen 12 an image of the view. The objective lenses of the systems 62 and 64 have the same angular field so that the photocell 56 will be effective to average the light over the same angular field of the view which is

projected onto the screen 12. The connections and operating action otherwise are the same as in Fig. 1.

In the modification shown in Fig. 6, the level of the picture signals is maintained substantially constant by taking picture signals from a suitable stage of the transmitter amplifier, and applying these, by way of a connection 66, to the grid circuit of a triode 68 which operates to integrate these signals. The resulting signal in the output of the tube 68 is amplified by a suitable tube 70 and applied by a connection 72 to the control grid 18. In this manner, the intensity of the ray 16 is made to vary automatically with and inversely proportionally to occurring variations in the average amplitude of the picture signals for each frame. This action operates to maintain the level of the transmitted picture signals substantially constant.

It will be understood that various other modifications, within the conception of those skilled in the art, are possible without departing from the spirit of my invention or the scope of the claims.

I claim as my invention:

1. In a television transmitter, a cathode ray tube for developing picture signals, said tube having an extended photo-sensitive screen structure and means including an electron gun for producing a ray of electrons and directing the ray towards said screen structure, means for scanning said screen structure with said ray whereby picture signals are developed in accordance with conditions of light and shade on said screen, means for developing an electrical effect which varies substantially in correspondence with occurring variations in conditions of average light-intensity over the portion of said screen structure being scanned, and means for changing the intensity of said ray in response to variations in said electrical effect whereby the level of the transmitted picture signals is controlled.

2. In the art of television transmission, the method of operation which comprises developing a cathode ray and directing the same at screen structure, deflecting the ray to cause the same to scan an area of said structure at a given rate expressed in terms of the number of times per second the ray scans said area, and increasing the intensity of the ray at said given rate and to substantially the same level each time.

3. In the art of television transmission, the method of operation which comprises developing a cathode ray and directing the same at screen structure, deflecting the ray back and forth at a given rate to cause the same to scan an area of said structure along a given number of lines a second, and increasing the intensity of the ray to a given level during a relatively small part of the time for one deflection of the ray and at said given rate.

4. In the art of television transmission, the method of operation which comprises developing a cathode ray and directing the same at screen structure, deflecting the ray in one direction at a relatively high frequency and in a direction perpendicular to said one direction at a relatively low frequency to cause the ray to scan an area of said structure, increasing the intensity of the ray to a given level at a rate corresponding to said high frequency, and increasing the intensity of the ray to a level substantially higher than said given level and at a rate corresponding to said low frequency.

5. In the art of television transmission, the

method of operation which comprises developing a cathode ray and directing the same at screen structure, deflecting the ray to cause the same to scan an area of said structure, maintaining the intensity of the ray within a given range during the scanning of said area for the development of picture signals, and increasing the intensity of the ray at least once during each scanning of said area to a level substantially beyond said range and only at an instant when the ray is directed at an edge of said area.

6. In the art of television transmission, the method of operation which comprises developing a cathode ray and directing the same at screen structure, deflecting the ray to cause the same to scan an area of said structure, maintaining the intensity of the ray within a given range during the scanning of said area for the development of picture signals, and increasing the intensity of the ray to a level substantially beyond said range and only at each instant when the ray is directed at one and the same edge of said area.

7. In the art of television transmission, the method of operation which comprises developing a cathode ray and directing the same at screen structure, deflecting the ray to cause the same to scan an area of said structure at a given rate expressed in terms of the number of lines scanned per second, varying the intensity of the ray through a given range and at a rate equal to said given rate to develop synchronizing impulses, and varying the intensity of the ray through a given range and at a rate equal to the required framing rate.

8. In a television transmission system, means comprising a cathode ray tube for developing picture signals, said tube being provided with screen structure and with an electron gun for developing a ray of electrons and directing the ray at said structure, said gun comprising a control electrode for controlling the intensity of the ray, an electrical system for developing an electrical effect which varies in correspondence with occurring variations in conditions of average light-intensity over the effective portion of said screen structure, and a connection between said electrical system and said control electrode whereby the potential on the latter is made to vary responsive to occurring variations of said electrical effect.

9. In a television transmission system, means comprising a cathode ray tube for developing picture signals, said tube being provided with photosensitive screen structure and with an electron gun for developing a ray of electrons and directing the ray at said structure, said gun comprising a control electrode for controlling the intensity of the ray, means for deflecting the ray at a given rate, a generator of electrical impulses occurring at said given rate, and means for applying said impulses to said control electrode with such polarity as to increase the intensity of said ray.

10. In a television transmission system, means comprising a cathode ray tube for developing picture signals, said tube being provided with photosensitive screen structure and with an electron gun for developing a ray of electrons and directing the ray at said structure, said gun comprising a control electrode for controlling the intensity of the ray, means for causing the ray to scan an area of said structure comprising means for deflecting the ray in a given direction at a relatively high frequency and means for

deflecting the ray in another direction at a relatively low frequency, means for generating electrical impulses at said relatively high frequency and at a given amplitude and electrical impulses at said relatively low frequency and at an amplitude substantially greater than said given amplitude, and connecting means for applying all of said impulses to said control electrode.

11. In a television transmission system, means comprising a cathode ray tube provided with photosensitive screen structure and with an electron gun for developing a ray of electrons and directing the ray at said structure, said gun comprising a control electrode for controlling the intensity of the ray, means for causing the ray to scan an area of said structure including means for generating two electrical waves of different frequencies, means for driving said last-named means comprising a generator of impulses at a given amplitude and occurring at one of said frequencies and of impulses at an amplitude substantially greater than said given amplitude and occurring at the other of said frequencies, and connecting means for applying all of said impulses to said control electrode.

12. In the art of television transmission, the method of operation which comprises developing a cathode ray and directing the same at screen structure, and deflecting the ray to cause the same to scan an area of said structure to develop picture signals and simultaneously and continuously varying the intensity of the ray over a given range and at a carrier frequency to develop a carrier wave for the picture signals.

13. In a television transmission system, a cathode ray tube for developing picture signals, said tube being provided with photo-electric screen structure and with an electron gun for developing a ray of electrons and directing the ray at said structure, said gun being provided with a control electrode for controlling the intensity of the ray, and means for transmitting synchronizing impulses, said means including an electrical circuit connected to said control electrode and operating to vary in a predetermined manner the ray intensity during operation of said system.

14. In television transmission system, a cathode ray tube for developing picture signals, said tube being provided with photosensitive screen structure and with an electron gun for developing a ray of electrons and directing the ray at said structure, said gun being provided with a control electrode for controlling the intensity of the ray, means for generating an electrical wave at carrier frequency, and connecting means between said generating means and said control electrode for applying said wave to the latter.

15. In a television transmission system, a cathode ray tube for developing picture signals, said tube being provided with photosensitive screen structure and with an electron gun for developing a ray of electrons and directing the ray at said structure, said gun being provided with a control electrode for controlling the intensity of the ray, means for deflecting the ray to cause the same to scan an area of said structure, said deflecting means including electrical circuits operating respectively at a relatively high frequency and at a relatively low frequency, means for developing and applying to said circuits driving impulses operating to maintain operation of said circuits at the respective frequencies, and connecting means between said impulse-developing

means and said control electrode for applying each of said impulses to the latter.

16. In a television transmission system, a cathode ray tube for developing picture signals, said tube being provided with photosensitive screen structure and with an electron gun for developing a ray of electrons and directing the ray at said structure, said gun being provided with a control electrode for controlling the intensity of the ray, means for deflecting the ray at a given frequency, a generator of impulses occurring at said frequency and operating to maintain operation of said deflecting means at said frequency, a generator of an electrical wave at carrier frequency, and connecting means between said electrode and both of said generators for applying the carrier wave and each of said impulses to said electrode.

17. In a television transmitter, a cathode ray tube for developing picture signals, said tube having an extended photo-sensitive screen structure and means including an electron gun for pro-

ducing a ray of electrons and directing the ray towards the screen structure, means for deflecting the ray back and forth at a given rate to cause the same to scan an area of said structure along a given number of lines a second, and means for increasing the intensity of the ray to a given level during a relatively small part of the time for one deflection of the ray and at said given rate.

18. In television transmitter, a cathode ray tube for developing picture signals, said tube having an extended photo-sensitive screen structure and means including an electron gun for producing a ray of electrons and directing the ray toward said screen structure, means for deflecting said ray comparatively slowly in one direction and for returning said ray comparatively rapidly in the opposite direction during a return period and means for increasing the intensity of said ray during at least a portion of said return period.

GREGORY N. OGLOBLINSKY.