

(No Model.)

J. RAU.

FAN ATTACHMENT FOR CRADLES.

No. 382,386.

Patented May 8, 1888.

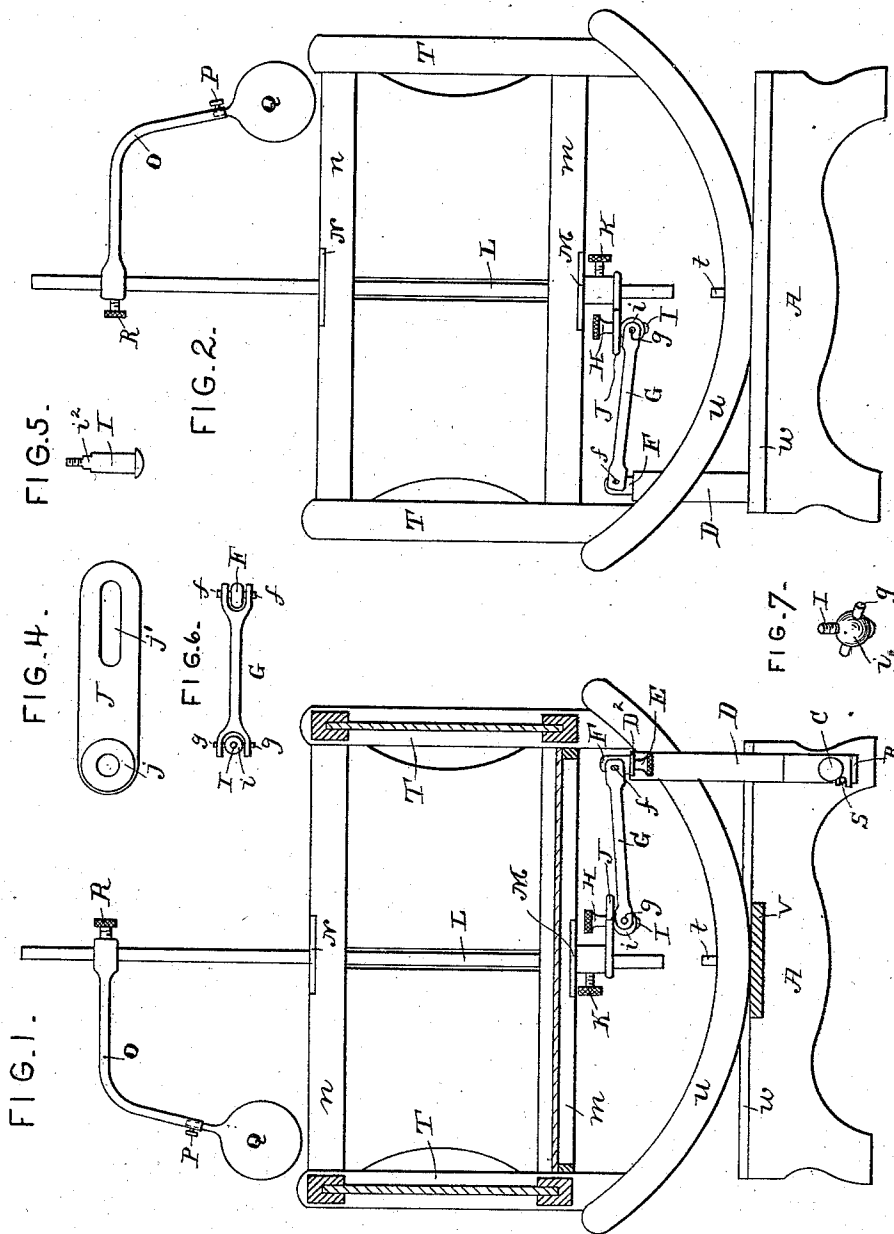

ATTEST.
Harry L. Amer.
E. W. Wurdeman.

INVENTOR.
John Rau.

UNITED STATES PATENT OFFICE.

JOHN RAU, OF BELLEVILLE, ILLINOIS, ASSIGNOR OF ONE-HALF TO A. F. KLOTZBACH, OF SAME PLACE.

FAN ATTACHMENT FOR CRADLES.

SPECIFICATION forming part of Letters Patent No. 382,386, dated May 8, 1888.

Application filed March 31, 1887. Serial No. 233,119. (No model.)

To all whom it may concern:

Be it known that I, JOHN RAU, a citizen of the United States, residing at Belleville, in the county of St. Clair and State of Illinois, have invented a new and useful Improvement in Fan Attachments for Cradles and other Moving Articles of Furniture, of which the following is a specification.

My invention relates to improvements in fan attachments in which a fan is made to swing horizontally in a segment of a circle while its vertical support swings laterally; and the objects of my improvement are to operate said fan and support in a simple manner by means of cranks and levers connected at one end with the stationary support of the cradle, and independently of ropes and pulleys and bearings therefor. I attain these objects by the construction illustrated in the accompanying drawings, in which—

Figure 1 is a transverse vertical section of a cradle having a fan attachment constructed in accordance with my invention. Fig. 2 represents in elevation the head of the cradle, to which my fan attachment is secured. Fig. 3 is a front view of a portion of the cradle-support carrying a screw-tapped plate to retain the stationary part of the fan attachment. Fig. 4 is a top view of the adjustable crank used to oscillate the fan-supporting shaft. Fig. 5 is a side view of the adjustable wrist-pin for said crank. Fig. 6 is a top view of the forked connecting-rod with the connecting-links at the ends thereof. Fig. 7 is a perspective view of the connecting-link *i* in the form of a ball having projecting pins or trunnions *g* and carrying the wrist-pin *l*.

Similar letters refer to similar parts throughout the several views.

In said drawings, *A*, represents the stationary supports for the cradle. They are united together by the bar *v*, and the top thereof is grooved at *w* to guide the supplemental rockers *u* of the cradle, and said rockers are bored vertically in their centers to receive loosely the retaining-pins *t*, projecting upward from the tops of the cradle-supports *A*.

To removably secure the lower end of the fan attachment to one of the supports *A*, there is attached, preferably to the inner side thereof, a plate, *B*, Fig. 3, having a screw-tapped per-

foration, *b*, to receive a thumb-screw, *C*, made to pass through the lower end of the standard *D* of the fan attachment. The plate *B* has also a pin or leg, *S*, projecting from its face to enter a notch, or runs in the lower end of the standard to prevent said standard from swinging on the screw *C*, but helps to retain it vertically in connection with said screw. The upper end of the standard is bent horizontal at *D*², and said horizontal portion has a perforation to receive the small end of the shouldered pin *F*, said pin being retained in position but capable of some rotation, but without racking or lost motion, by a thumb-nut placed upon its screw-threaded small end, the top of said nut abutting against the shoulder on said pin.

The upper end of the pin *F* is flattened and retained between the branches of the fork end of the connecting-rod *G* by a small pin, *f*, passing therethrough. The opposite end of the rod *G* is similarly forked and connected by small pins *g*, projecting from the sides of a ball, *i*, through which passes a vertical wrist-pin, *l*, adjustably retained in a slot, *j*, of the crank *J*. Said wrist-pin has a reduced portion, *j*², to pass through the slot *j* and form a shoulder against the under side of the crank, and a thumb-nut, *H*, placed on the small screw-threaded end of the pin *l* retains said pin connected with the crank; but its shoulders render it capable of semi-rotation without racking or lost motion. By either construction the connecting-rod is provided with a universal joint at each end, which permits it to rock both vertically and horizontally at each end, and thereby follow the motion of the cradle without causing any strain upon the joints. The crank *J* is provided with a perforated boss, *j*, to receive the vertical rod *L*, and is secured thereto by the thumb-screw *K*. This rod *L* passes through a bearing, *M*, projecting from the bottom rail of the cradle, and through a bearing, *N*, projecting from the upper rail of said cradle. A shoulder is formed on the rod *L* to rest upon the lower bearing, *M*, and for that purpose the hole in said bearing is preferably of smaller diameter than the hole in the upper bearing, *N*. At a suitable point above said upper bearing is secured on the rod *L*, by means of a thumb-screw, *R*, the arm *O*, carrying on its outer end the fan *Q*, secured

thereto by the screw P. The length of the fan-arm O is less than half the width of the cradle, so as not to come in contact with a person passing alongside thereof or a person that rocks the cradle.

As one end of the fanning apparatus is retained stationary by the standard D, while the other end is screwed to a movable body, as a crank, the fan follows the motion of the latter, and is thereby made to oscillate horizontally over said cradle, and the extent of the oscillation is regulated by setting the pin H at a suitable point of the slot *j'* in the crank J of the fan attachment.

Having now fully described my invention, I claim—

1. The combination of the stationary support of a cradle, a standard secured thereto, a pin, F, on top of said standard, a cradle, a vertical rod, L, pivoted thereto and having

an arm carrying a fan, a crank upon said rod, a pin, I, adjustably secured to said crank, and a rod, G, connecting the pins F and I, substantially as and for the purpose described.

2. The combination of the stationary support of a cradle, a screw-tapped plate, B, secured thereto and having a lug, S, a standard having a notch to receive said lug and a thumb-screw, and a pivot-pin, F, on top of said standard, with a vertical rod mounted upon the cradle and a fan secured thereto, a crank adjustably retained upon said rod, a connecting-rod, and a pin uniting it adjustably to said crank, substantially as and for the purpose described.

In testimony whereof I affix my signature in presence of two witnesses.

JOHN RAU.

Witnesses:

HARRY L. AMER,
E. C. WURDEMAN.