

(19) World Intellectual Property Organization  
International Bureau



(43) International Publication Date  
31 August 2006 (31.08.2006)

PCT

(10) International Publication Number  
**WO 2006/091686 A2**

(51) International Patent Classification:  
A61F 2/30 (2006.01)

[US/US]; 49 Powder Hill Road, Bolton, Massachusetts  
01740 (US).

(21) International Application Number:  
PCT/US2006/006323

(74) Agents: PFLEGER, Edmund P., et al.; Grossman Tucker  
Perreault & Pflieger, PLLC, 55 South Commercial Street,  
Manchester, New Hampshire 03101 (US).

(22) International Filing Date:  
22 February 2006 (22.02.2006)

(81) Designated States (unless otherwise indicated, for every  
kind of national protection available): AE, AG, AL, AM,  
AT, AU, AZ, BA, BB, BG, BR, BW, BY, BZ, CA, CH, CN,  
CO, CR, CU, CZ, DE, DK, DM, DZ, EC, EE, EG, ES, FI,  
GB, GD, GE, GH, GM, HR, HU, ID, IL, IN, IS, JP, KE,  
KG, KM, KN, KP, KR, KZ, LC, LK, LR, LS, LT, LU, LV,  
LY, MA, MD, MG, MK, MN, MW, MX, MZ, NA, NG, NI,  
NO, NZ, OM, PG, PH, PL, PT, RO, RU, SC, SD, SE, SG,  
SK, SL, SM, SY, TJ, TM, TN, TR, TT, TZ, UA, UG, US,  
UZ, VC, VN, YU, ZA, ZM, ZW.

(25) Filing Language: English

(26) Publication Language: English

(30) Priority Data:  
60/654,989 22 February 2005 (22.02.2005) US

(71) Applicant (for all designated States except US):  
ARTHROSURFACE, INC. [US/US]; 28 Forge Parkway,  
Franklin, Massachusetts 02038 (US).

(84) Designated States (unless otherwise indicated, for every  
kind of regional protection available): ARIPO (BW, GH,  
GM, KE, LS, MW, MZ, NA, SD, SL, SZ, TZ, UG, ZM,  
ZW), Eurasian (AM, AZ, BY, KG, KZ, MD, RU, TJ, TM),

(72) Inventor; and

(75) Inventor/Applicant (for US only): EK, Steven W.,

[Continued on next page]

(54) Title: ARTICULAR SURFACE IMPLANT

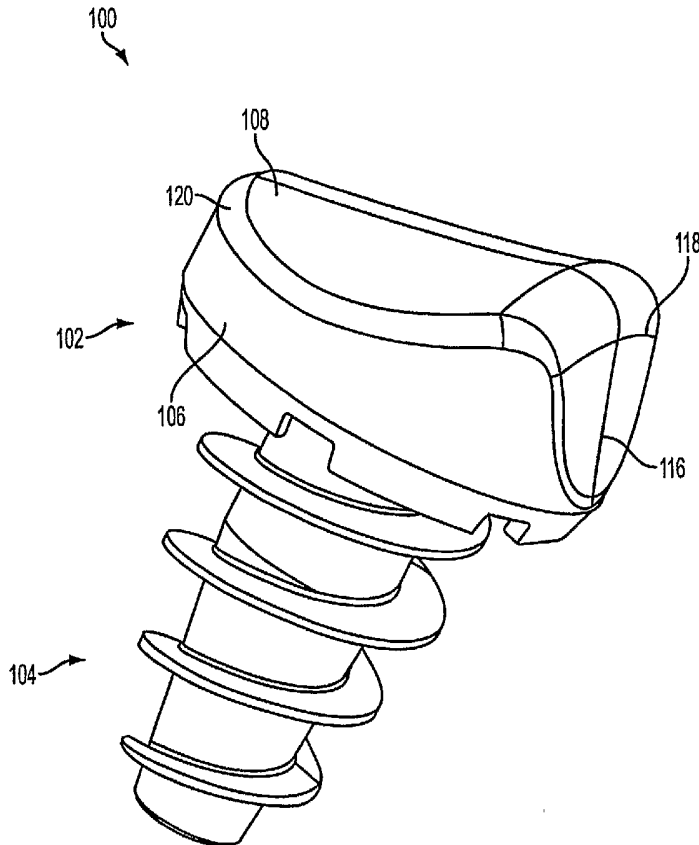

(57) Abstract: An implant for replacing a portion of an articular surface including a load bearing surface and a bone contacting region. The load bearing surface had a contour defined by a first curve string which is based on a contour of the articular surface being replaced in a first plane. The load bearing surface of the implant is further defined by the contour of the articular surface being replaced in a second plane, in which the first and second planes are mutually intersection planes.

WO 2006/091686 A2



European (AT, BE, BG, CH, CY, CZ, DE, DK, EE, ES, FI, FR, GB, GR, HU, IE, IS, IT, LT, LU, LV, MC, NL, PL, PT, RO, SE, SI, SK, TR), OAPI (BF, BJ, CF, CG, CI, CM, GA, GN, GQ, GW, ML, MR, NE, SN, TD, TG).

*For two-letter codes and other abbreviations, refer to the "Guidance Notes on Codes and Abbreviations" appearing at the beginning of each regular issue of the PCT Gazette.*

**Published:**

- *without international search report and to be republished upon receipt of that report*

## ARTICULAR SURFACE IMPLANT

## FIELD

The present disclosure is directed at a system and method for accessing an  
5 articular joint surface. The present disclosure is further directed at a method and system  
for replacing at least a portion of an articular surface.

## BACKGROUND

Articular cartilage, found at the ends of articulating bone in the body, is typically  
10 composed of hyaline cartilage, which has many unique properties that allow it to  
function effectively as a smooth and lubricious load bearing surface. Hyaline cartilage  
problems, particularly in knee, hip joints, and shoulder joints, are generally caused by  
disease such as occurs with rheumatoid arthritis or wear and tear (osteoarthritis), or  
secondary to an injury, either acute (sudden), or recurrent and chronic (ongoing). Such  
15 cartilage disease or deterioration can compromise the articular surface causing pain and  
eventually, loss of joint movement. As a result, various methods have been developed  
to treat and repair damaged or destroyed articular cartilage.

For smaller defects, traditional options for this type of problem include leaving  
the lesions or injury alone and living with it, or performing a procedure called abrasion  
20 arthroplasty or abrasion chondralplasty. The principle behind this procedure is to  
attempt to stimulate natural healing. The bone surface is drilled using a high speed  
rotary burr or shaving device and the surgeon removes about 1mm of bone from the  
surface of the lesion. This creates an exposed subchondral bone bed that will bleed and  
will initiate a fibrocartilage healing response. One problem with this procedure is that  
25 the exposed bone is not as smooth as it originally was following the drilling and burring  
which tends to leave a series of ridges and valleys, affecting the durability of the  
fibrocartilage response. Further, although this procedure can provide good short term  
results, (1-3 years), fibrocartilage is seldom able to support long-term weight bearing and  
is prone to wear, soften and deteriorate.

30 Another procedure, called Microfracture incorporates some of the principles of  
drilling, abrasion and chondralplasty. During the procedure, the calcified cartilage layer  
of the chondral defect is removed. Several pathways or "microfractures" are created to  
the subchondral bleeding bone bed by impacting a metal pick or surgical awl at a  
minimum number of locations within the lesion. By establishing bleeding in the lesion

and by creating a pathway to the subchondral bone, a fibrocartilage healing response is initiated, forming a replacement surface. Results for this technique may be expected to be similar to abrasion chondralplasty.

Another means used to treat damaged articular cartilage is a cartilage transplant. Essentially, this procedure involves moving cartilage from an outside source or other knee or from within the same knee into the defect. Typically, this is done by transferring a peg of cartilage with underlying bone and fixing it in place with a screw or pin or by a press fit. Although useful for smaller defects, large defects present a problem, as this procedure requires donor pegs proportionate to the recipient bed. Large diameter lesions may exceed the capacity to borrow from within the same knee joint and rule out borrowing from another source.

Larger defects, however, generally require a more aggressive intervention. Typically treatment requires replacing the articular surface with an implant or prosthetic having an outer layer that that is polished or composed of a material that provides a lubricious load bearing surface in approximation of an undamaged cartilage surface. Replacement of the articular surface requires first cutting, boring, or reaming the damaged area to remove the damaged cartilage. A recess to receive an implant or prosthetic is formed at the damaged site. The implant or prosthetic is then secured to the bone in an appropriate position in the recess.

20

#### BRIEF DESCRIPTION OF THE DRAWINGS

The subject matter of the present disclosure is set forth by description of embodiments consistent therewith, which description should be considered in combination with the accompanying drawings, wherein:

FIG. 1 is an exploded perspective view of an embodiment of an implant system including an implant consistent with the present disclosure and a fixation element that may be used in conjunction with the implant;

FIG. 2 is a perspective view of the embodiment of an implant system shown in FIG. 1 showing the implant assembled to the fixation element;

FIG. 3 is a perspective view of another embodiment of an implant system consistent with the present disclosure including an implant and a fixation element;

FIG. 4 illustrates the implant system shown in FIG. 3 from another perspective;

FIG. 5 shows an ankle including a talus implant consistent with the present disclosure;

FIG. 6 shows an ankle including a talus implant consistent with the present disclosure;

FIG. 7 shows an ankle including a talus implant consistent with the present disclosure;

5 FIG. 8 is a perspective view of another implant consistent with the present disclosure;

FIG. 9 shows the implant of FIG. 8 from another perspective;

FIG. 10 is a perspective view of yet another implant consistent with the present disclosure;

10 FIG. 11 shows the implant of FIG. 10 from another perspective; and

FIG. 12 shows of a trochlear implant consistent with the present disclosure.

### DESCRIPTION

By way of overview, the present disclosure may provide an implant for replacing  
15 at least a portion of an articular surface. Furthermore, the present disclosure is also directed at a general design methodology for developing and producing a surface contour of an implant for replacing at least a portion of an articular surface. An implant consistent with the present disclosure may be provided having a load-bearing surface that is adapted to interact with a cooperating articulating feature. The cooperating  
20 articulating feature may include, for example, a cooperating articular surface, a cooperating surface of an implant replacing at least a portion of a cooperating articular surface, etc. In one embodiment, a portion of an articular surface to be replaced by an articular surface implant herein may be identified and replaced using a minimally invasive surgical procedure, for example, using diagnostic and/or surgical arthroscopy  
25 procedures. Generally, an implant according to the present disclosure may have a load bearing surface that may be based on an original geometry of an articular surface to be replaced by the implant.

Referring to FIGS. 1 through 4, an embodiment of an implant system 100 is schematically depicted in various views. The implant system 100 may be employed to  
30 replace at least a portion of an articular surface, e.g., at least a portion of an articular surface of a joint. As shown, the implant system 100 may generally include an articular surface implant 102 and a fixation element 104. The fixation element 104 may be capable of coupling the implant 102 to bone and/or other tissue in the region of the portion of the articular surface to be replaced by the implant 102. As shown in the

illustrated embodiment of FIG. 1, the fixation element 104 may be provided as a separate component from the implant 102. In such an embodiment, the fixation element 104 may be capable of being coupled to the implant 102 and may be capable of being coupled to bone and/or tissue in the general region of the portion of the articular surface to be replaced by the implant system 100.

The articular surface implant 102 may generally include an implant body 106. The implant body 106 may have a load bearing surface 108 and a bone contacting region 110. The load bearing surface 108 may generally be configured to interact with a cooperating articulating feature, such as a cooperating articular surface, a cooperating articular surface implant, etc. In one embodiment, the implant body 106 may be at least partially received in an implant site provided by excising at least a portion of the articular surface and underlying bone. In such an embodiment, the load bearing surface 108 may be disposed generally replacing at least a portion of the excised articular surface. In an embodiment herein, the bone contacting region 110 may engage and/or contact subchondral within and/or forming at least a portion of a bottom of the implant site.

As mentioned previously, and consistent with the illustrated embodiment, the fixation element 104 may be provided as a separate component from the implant 102. Providing the fixation element 104 as a separate component from the implant 102 may facilitate installation of the implant system 100. The fixation element 104 may first be coupled to bone and/or other tissue in and/or around the implant site. The implant 102 may then be positioned relative to the surrounding articular surface and the implant 102 may be coupled to the fixation element 104. In such a manner, the implant 102 may be secured in position relative to the articular surface.

In the illustrated embodiment, the fixation element 104 is depicted as a screw-type feature. Consistent with this illustrated embodiment, the fixation element 104 may be threadably engaged with bone and/or other tissue in and/or around the implant site. In addition to engaging bone and/or other tissue, a screw-type fixation element 104 may also facilitate depth positioning of the fixation element 104, and thereby depth positioning of the implant 102, relative to the articular surface. Suitable screw-type fixation elements are known in the art, for example, from U.S. Patent No. 6,520,964, issued on February 18, 2003. Consistent with various alternative embodiments, the fixation element may be configured having a barbed member or other similar features capable of engaging bone and/or other tissue in and/or around the implant site. In still

other embodiments, the fixation element may include features that may be adhesively coupled to bone and/or other tissue in and/or around the implant site.

As illustrated, in an embodiment consistent with the present disclosure, the implant 102 and the fixation element 104 may be provided as separate components. The implant 102 may be coupled to the fixation element 104 to, at least in part, secure the implant 102 in position in the implant site. The implant 102 and the fixation element 104 may, accordingly, include interacting features wherein the implant 102 and fixation element 104 are capable of being coupled to one another. An embodiment of an implant 102 may be provided including a post 112 extending from the implant body 106. The fixation element 104 may include an opening 114 capable of receiving at least a portion of the post 112. In one such embodiment, the post 112 and the opening 114 may be provided having complimentary precision tapers. The implant 102 and the fixation element 104 may be coupled to one another by inserting the post 112 into the opening 114 and pressing the features together, e.g., as by applying an impact force. The precision taper of the post 112 and the opening 114 may achieve a secure frictional interaction between the implant 102 and the fixation element 104.

Various additional and/or alternative features and/or arrangements may be utilized for coupling the implant and the fixation element within the context of the present disclosure. Furthermore, in various embodiments in which the implant and the fixation element are provided as separate components, the implant and the fixation element may be assembled to one another prior to installation into an implant site. Consistent with some such embodiments, the fixation element may be configured to engage and/or to be coupled to bone and/or tissue in and/or around the implant site during installation. In one such embodiment, the fixation element may include a barbed post or similar feature. According to still further embodiments, the implant and the fixation element may be provided as a unitary structure.

The illustrated implant system 100 depicted in FIGS. 1 through 7 shows an implant 102 configured to replace a portion of the articular surface of the talus. Particularly, the illustrated implant system 100 shown in FIGS. 1 through 7 is configured to replace at least a portion of the lateral ridge of the trochlear surface of the talus, which articulates with the tibia. Damage to the lateral ridge of the trochlear surface of the talus may include fracture or shearing off of a portion of the ridge resulting from trauma. From a general perspective, the load bearing surface 108 may have a contour and/or geometry that may be capable of cooperating with an interacting articulating feature,

including a cooperating articular surface, at least a portion of an implant replacing at least a portion of a cooperating articular surface, etc. In the context of the illustrated embodiment, the load bearing surface 108 may have a contour and/or geometry that may be capable of cooperating with an interacting articular surface of a tibia. According to a  
5 related embodiment in the context of the illustrated embodiment, the load bearing surface 108 of the implant 102 may include a geometry and/or contour that may be capable of cooperating with an interacting surface of an implant replacing at least a portion of an articular surface of a tibia.

Consistent with the foregoing, an implant may include a load bearing surface  
10 having a contour and/or geometry that may be capable of cooperating with an interacting articulating surface. In one embodiment, the load bearing surface may have a contour and/or geometry that may generally approximate and/or be based on a contour and/or geometry of the portion of the articular surface being replaced by the implant. In an  
15 embodiment, the portion of the articular surface being replaced may be mapped using various known techniques to quantitatively and/or qualitatively assess the contour and/or geometry of the portion of the articular surface that may be replaced by the implant. An implant may be constructed and/or selected from a set of implants having various contours and/or geometries. Consistent with such an embodiment, the load bearing  
20 surface of the implant may be based on the contour and/or geometry of the portion of the articular surface to be replaced by the implant. In an alternative embodiment, an implant may be fabricated or selected from a set of standard size and/or shape implants to provide a general approximation of the articular surface being replaced. Selection and/or  
25 fabrication of an implant may rely on various degrees of quantitative reference to the articular surface being replaced, including no quantitative reference to the articular surface.

Referring to FIGS. 1 through 4, according to one aspect, a contour and/or  
geometry of the load bearing surface 108 of an implant 102 may generally be defined by  
a first curve string 116 and a second curve string 118. As used in any embodiment  
herein, a curve string may include a single curve and/or a plurality of curves joined  
30 together curves in a plane. The first curve string 116 and the second curve string 118 generally defining the contour and/or geometry of the load bearing surface 108 may be disposed in intersecting planes. In the illustrated embodiment, the plane of the first  
curve string 116 and the plane of the second curve string 118 may generally be mutually



perpendicular. Various other angular relationships of the planes including the first curve string 116 and the second curve string 118 may also suitably be employed herein.

A design methodology capable of achieving a load bearing surface of an implant herein may include providing a curve string defining a contour and/or geometry of the load bearing surface and sweeping the curve string along another curve string defining an intersecting contour and/or geometry of the load bearing surface. As alluded to above, curve strings defining the contour and/or geometry of the load bearing surface may be derived based on mapped curves and/or approximations of curves of a portion of an articular surface to be replace, a portion of a cooperating articulating feature, etc. In one such embodiment, measurements of the contour and/or geometry of the portion of the articular surface to be replaced may be taken. Measurement of the contour and/or geometry of the portion of the articular surface to be replaced by the implant may be achieved using direct contact contour mapping of the articular surface, e.g., measuring relative heights of various regions of the articular surface, and/or using various imaging techniques, such as radiological imaging techniques.

According to one embodiment, the load bearing surface 108 may have a contour and/or geometry corresponding to the second curve string 118 lofted over the first curve string 116. In one such embodiment, the contour and/or geometry of the load bearing surface 108 may be achieved by sweeping the second curve string 118 along the first curve 116 while maintaining the second curve 118 normal to the first curve 116. In such an embodiment, the first curve 116 may be provided in a first plane, e.g. a plane defined by the X and Z axis. The second curve 118 may be provided in a perpendicular plane. The angular pitch of the perpendicular plane relative to the first plane may vary along the first curve 116 to maintain the second curve 118 normal to the first curve 116 along the sweep of the first curve 116. According to another embodiment, the second curve 118 may be swept along the first curve 116 with the first curve 116 and the second curve 118 in orthogonal planes. For example, the first curve 116 may be provided in a first plane, e.g., a plane defined by the Y and Z axis and the second curve may be provided in an orthogonal plane, e.g., a plane defined by the X and Z axis. As shown in FIGS. 3 and 4, an embodiment of an implant provided consistent with the preceding design methodology may be generally symmetrical in each of the planes including the first curve string and the second curve string.

In another embodiment the load bearing surface 108 may have a contour and/or geometry resulting from a faired transition between the first curve string 116 and the

second curve string 118. That is, the contour and/or geometry of the load bearing surface 108 may be provided by a smooth transition between the first curve string 116 and the second curve string 118 at each quadrant between the first curve string 116 and the second curve string 118. In similar embodiments, providing a faired transition between the first curve string and the second curve string may be achieved using various averaging techniques known for surface generation. Various such averaging techniques are commonly employed in commercial surfacing design and solid modeling computer assisted drafting software packages.

The implant 102 may include a relieved edge 120 around the perimeter of the load bearing surface 108. The relieved edge 120 may include a rounded over, e.g., radiused, edge, a chamfer edge, etc. According to one aspect, when the implant 102 is installed in an articular surface and replacing at least a portion of the articular surface, the relieved edge 120 around the load bearing surface 108 may reduce the presence of a hard edge at a transition between the implant and surrounding articular surface. A reduction and/or elimination of a hard edge at the transition between the load bearing surface of the implant and the surrounding articular surface may reduce and/or eliminate scraping of an interacting articular surface during articulation of the joint. Additionally, the relieved edge 120 may accommodate manufacturing and/or installation tolerances. The relieved edge 120 may permit smooth operation of the joint in a situation in which the implant 102 sits slightly proud above and/or slightly recessed below the surrounding articular surface.

With particular reference to FIGS. 5 through 7, the load bearing surface 108 of the implant is depicted. As mentioned previously the illustrated implant system 100 may replace a portion of the lateral trochlear ridge of the talus. In one embodiment, an implant site may be prepared using a rotating excision tool, e.g., an excision blade rotating about an axis. Accordingly, the implant site may include a circular excision projected along the axis of rotation of the excision blade. In such an embodiment, the cross-sectional geometry of the implant may generally correspond to the intersection of a projected circular excision with the articular surface of the talus. Various additional and/or alternative excision site preparation tools and techniques are also contemplated by the present disclosure, along with the attendant changes to the implant configuration.

The location of the fixation element and the orientation of the load bearing surface to the fixation element may be selected to provide secure and stable anchoring of the implant relative to the articular surface. In an embodiment, the implant system may

have a configuration wherein the fixation element may extend into the talus at an angle to, and/or spaced from, the lateral ridge. Such a configuration may provide secure anchoring of the implant and/or may reduce the occurrence of tear-out and/or crumbling of the talus resulting from weakening of the talus caused by extension of the fixation element along the lateral face adjacent the trochlear surface. Various additional and/or alternative configurations may also be employed.

Turning to FIGS. 8 and 9, another embodiment of an implant 200 is shown. The illustrated implant 200 is generally configured to replace at least a portion of an articular surface of a patella. Similar to the previously described embodiment, the implant 200 may generally include an implant body 202 having a load bearing surface 204. The load bearing surface 204 of the illustrated implant 200 may have a contour and/or geometry that may suitably replace at least a portion of an articular surface of a patella. The implant 200 may also include a post 206 capable of coupling with a fixation element (not shown) for anchoring the implant 200 to an articular surface and/or underlying bone. Various other features in addition to, or as an alternative to, a post may be employed for coupling the implant 200 to a fixation element. Furthermore, an embodiment of an implant herein may be provided including an integral fixation element. In such an embodiment, the feature for coupling to a fixation element may optionally be excluded.

Similar to the preceding embodiment, the load bearing surface 204 of the implant 200 may be defined by a first curve string 208 and a second curve string 210. The contour and/or geometry of the load bearing surface 204 may be provided as the first curve string 208 lofted over the second curve string 210, and/or vice-versa. As previously described, the lofted load bearing surface 204 may be achieved by sweeping the first curve string 208 along the second curve string 210. In another embodiment, the load bearing surface of the implant may be provided using averaging algorithms to provide a faired surface in between the first curve string and the second curve string.

Yet another embodiment of an implant 300 is depicted with reference to FIGS. 10 and 11. The illustrated implant 300 may be capable of replacing at least a portion of a trochlear articular surface, for example a trochlear articular surface of a humerus, etc. As with the previously described embodiments, the implant 300 may generally include an implant body 302 having a load bearing surface 304. The load bearing surface 304 may be defined by a first curve string 306 and a second curve string 308. The load bearing surface 304 may be provided by sweeping the second curve string 308 along the first curve string 306 consistent with the previously described design methodology.

Furthermore, the load bearing surface may also be provided as a faired surface defined by a first and second intersecting curve string.

Referring to FIG. 12, a model articular surface is shown including an implant capable of replacing at least a portion of a trochlear surface is shown. The implant depicted in FIG. 12 may be generally consistent with the embodiment described with reference to FIGS. 10 and 11. The load bearing surface of the implant, visible in the photograph of the model, may generally have a contour and/or geometry that may generally correspond to the portion of the articular surface being replaced by the implant. In such an embodiment, the implant may provide smooth interaction with a cooperating articular surface, such as depicted in FIG. 12. As previously described, in one embodiment an implant site may be created in an articular surface using a rotating excision tool. A rotating excision tool may provide a circular cutting path that may be projected into the articular surface and/or the underlying subchondral bone. The shape of the implant may, in such an embodiment, generally correspond to the intersection of the circular cutting path and the articular surface.

In summary, according to one aspect, an implant may be provided for replacing a portion of an articular surface. The implant may include a load bearing surface having a contour defined by a first curve string based on a contour of the articular surface in a first plane and by a second curve string based on a contour of the articular surface in a second plane. The first and second planes may be planes which intersect one another. The implant may further include a bone contacting surface.

According to another aspect, the present disclosure may provide an implant system for replacing a portion of an articular surface. The implant system may include an implant having a load bearing surface which is defined by a first and a second curve string. The first curve string may be based on a contour of the articular surface in a first plane and the second curve string may be based on a contour of the articular surface in a second plane. The first and second planes may intersect one another. The implant system may also include a fixation element capable of engaging bone and capable of being coupled to the implant.

According to yet another aspect, the present disclosure may provide a method of forming an implant. The method may include measuring a contour of an articular surface in a first plane and measuring a contour of the articular surface in a second plane, in which the first and second planes are intersecting planes. The method may further include providing an implant body having a load bearing surface. The load bearing

surface of the implant body may have a contour defined by the contour of the articular surface in the first plane and the contour of the articular surface in the second plane.

While the embodiments of the implant system illustrated and described above are provided in the context of an implant configured to replace at least a portion of the talus, 5 patella, and humerus trochlea, an implant consistent with the present disclosure may be sized and shaped for replacing at least a portion of various other articular surfaces of the body. Accordingly, consistent with the present disclosure, an implant system may be provided to replace at least a portion of various articular surfaces in addition to a portion of an articular surface of a talus. For example, an implant herein may suitably be 10 employed to replace a portion of an articular surface of a knee joint, a hip joint, a shoulder joint, etc. Accordingly, the foregoing example should not be construed as limiting on the application of an implant consistent with the present disclosure.

What is claimed is:

1. An implant for replacing a portion of an articular surface comprising:  
a load bearing surface having a contour defined by a first curve string based on a contour of said articular surface in a first plane and a second curve string based on a contour of said articular surface in a second plane, said first and second planes being intersecting; and  
a bone contacting surface.
2. An implant according to claim 1, wherein said first and second planes are orthogonal.
3. An implant according to claim 1, wherein said load bearing surface contour comprises a contour defined by said second curve string lofted along said second curve string.
4. An implant according to claim 1, wherein said first curve string is based on a plurality of measurements of the articular surface in the first plane.
5. An implant according to claim 1, wherein said second curve string is based on a plurality of measurements of the articular surface in the second plane.
6. An implant according to claim 1, further comprising an attachment feature capable of coupling to one of a fixation element or an implant site.
7. An implant according to claim 6, wherein said attachment feature comprises a tapered post capable of engaging a fixation element.
8. An implant according to claim 1, wherein said load bearing surface is relieved around at least a portion of a perimeter of said load bearing surface.
9. An implant system for replacing a portion of an articular surface comprising;  
an implant having a load bearing surface defined by a first curve string based on a contour of said articular surface in a first plane and a second curve string based on a contour of said articular surface in a second plane, said first and second planes intersecting; and

a fixation element capable of engaging bone and capable of being coupled to said implant.

10. A system according to claim 9, wherein said first and second planes are orthogonal.
11. A system according to claim 9, wherein said load bearing surface contour comprises a contour defined by said second curve string lofted along said second curve string.
12. A system according to claim 9, wherein said fixation element comprises a threaded region capable of engaging bone.
13. A system according to claim 9, wherein said fixation element comprises an opening and said implant comprises a protrusion capable of being at least partially received in said opening for coupling said implant and said fixation element.
14. A system according to claim 9, wherein said first curve string is based on a plurality of measurements of the articular surface in the first plane.
15. A system according to claim 9, wherein said second curve string is based on a plurality of measurements of the articular surface in the second plane.
16. A method of forming an implant comprising:
  - measuring a contour of an articular surface in a first plane;
  - measuring a contour of said articular surface in a second plane, said first and second planes intersecting; and
  - providing an implant body having a load bearing surface, said load bearing surface having a contour defined by said contour of said articular surface in said first plane and said contour of said articular surface in said second plane.
17. A method according to claim 16, wherein said first and second planes are orthogonal.

18. A method according to claim 16, said implant body further comprising a bone contacting surface.

19. A method according to claim 16, wherein said load bearing surface contour is defined by said contour of said articular surface in said second plane lofted along said contour of said articular surface in said first plane.

20. A method according to claim 16, wherein measuring said contour of said articular surface in one of said first plane and said second plane comprises one of direct contact contour mapping and radiographic imaging.



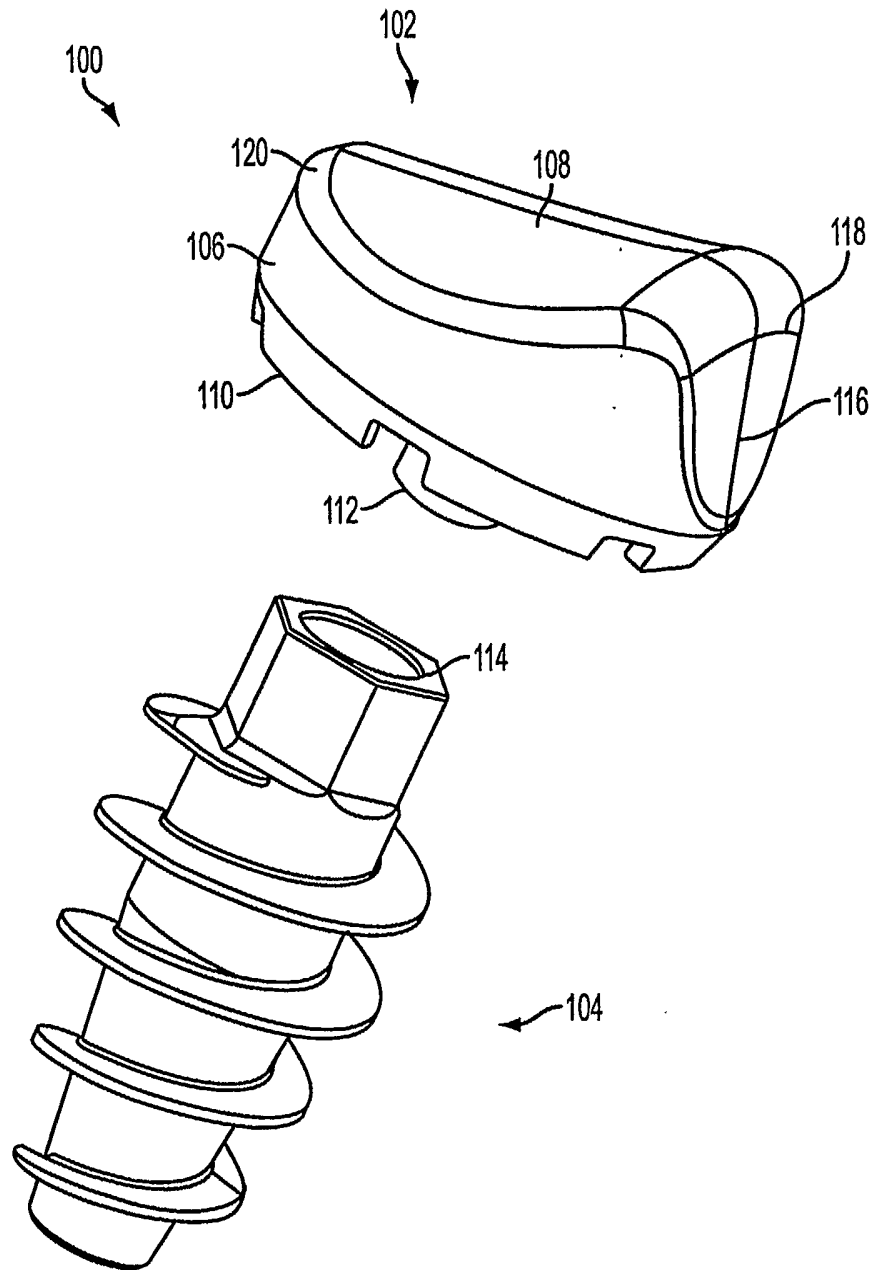

FIG. 1

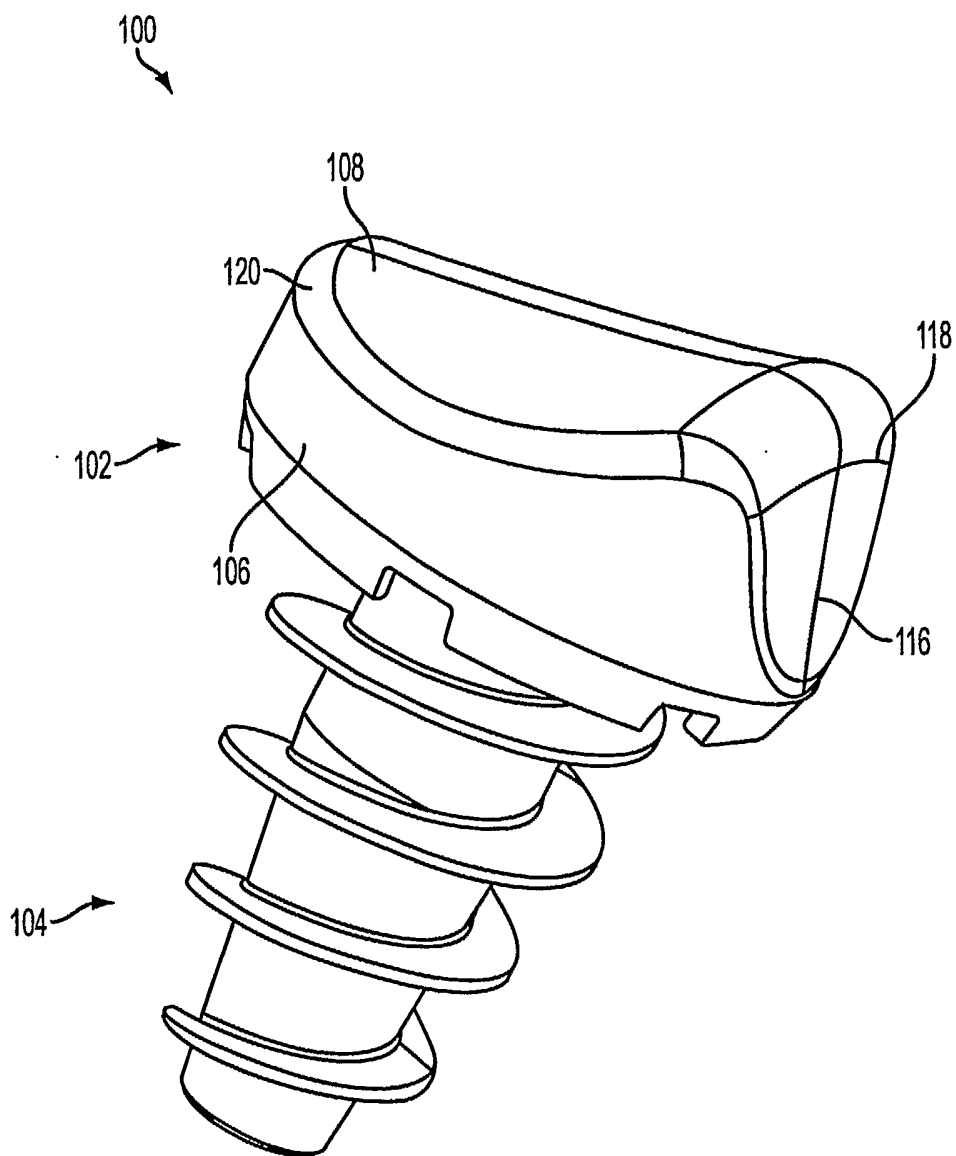

FIG. 2

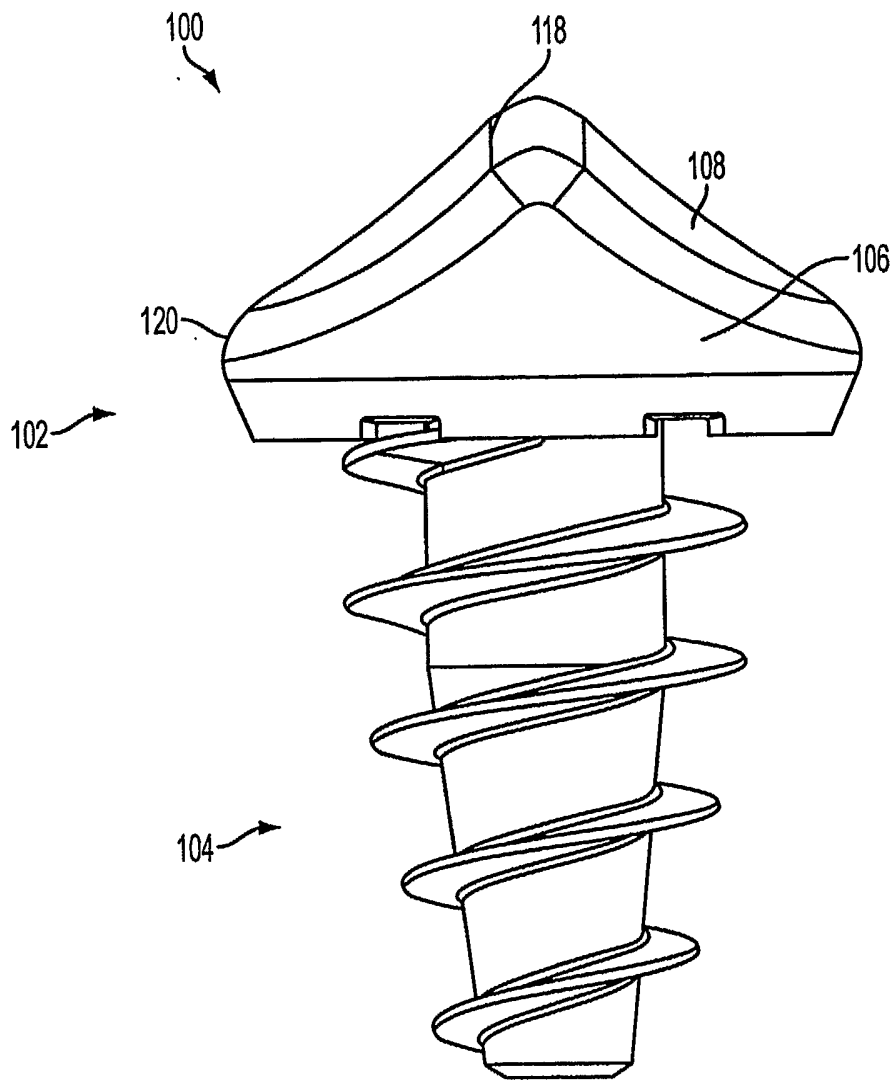

FIG. 3

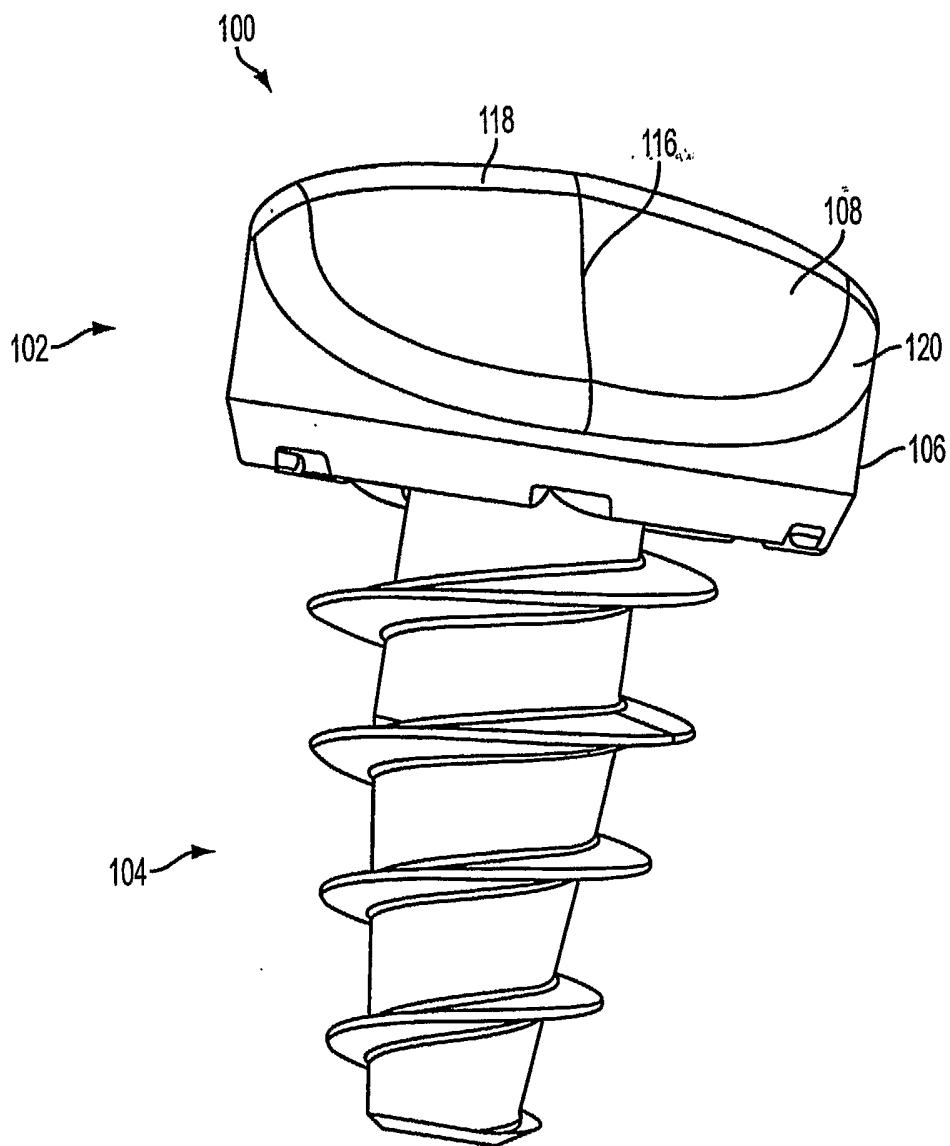

FIG. 4

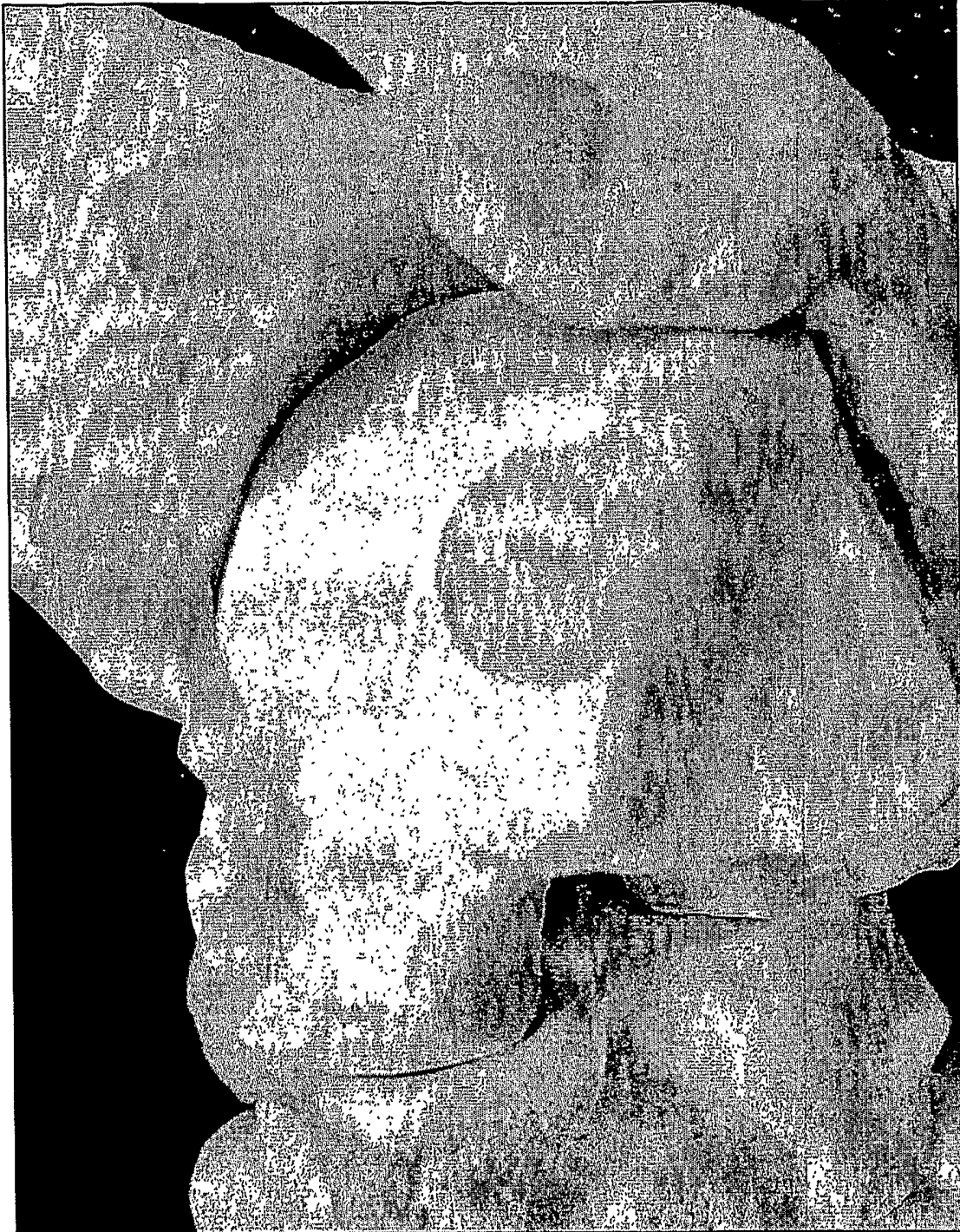

FIG. 5



FIG. 6

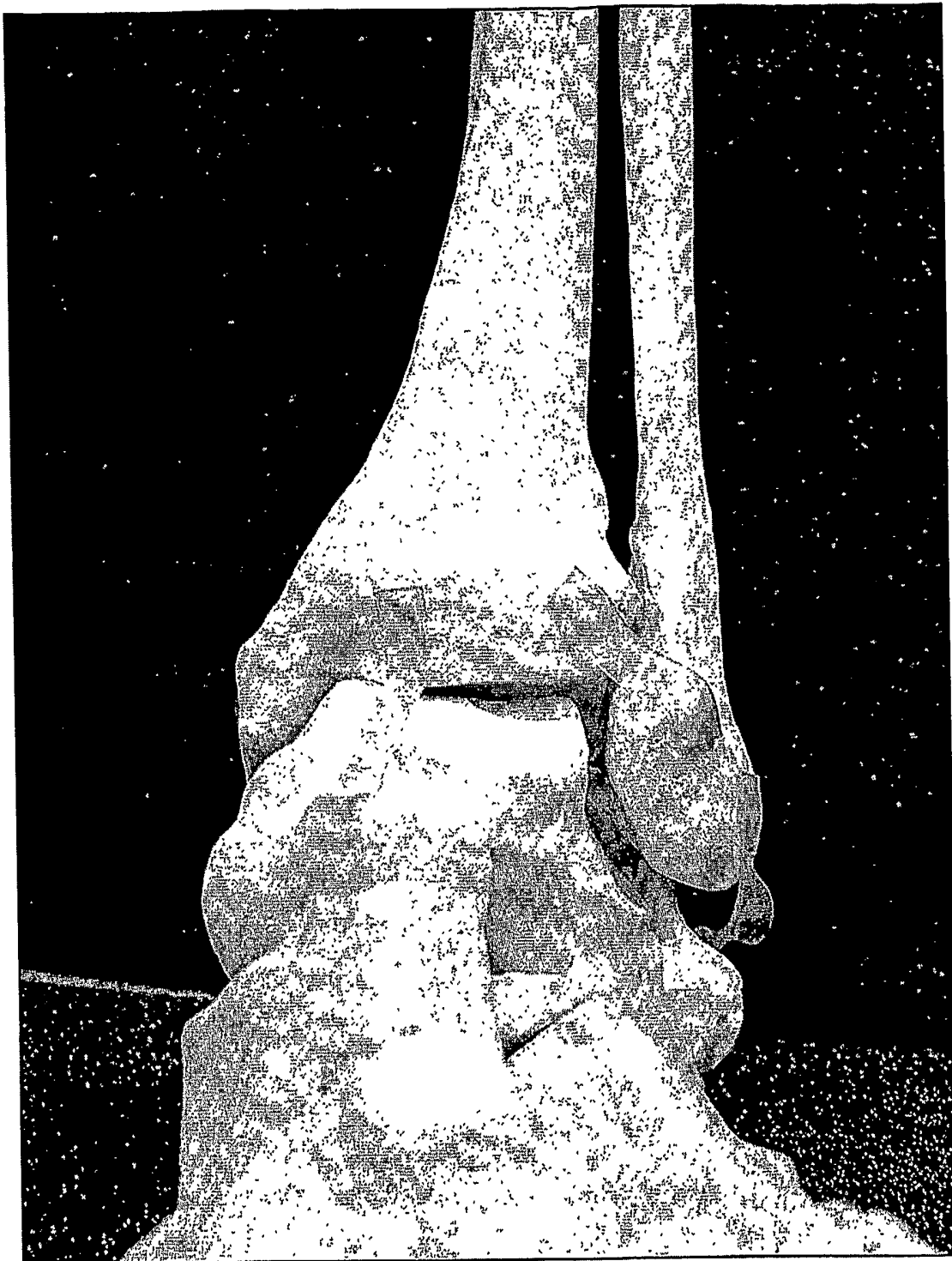

FIG. 7

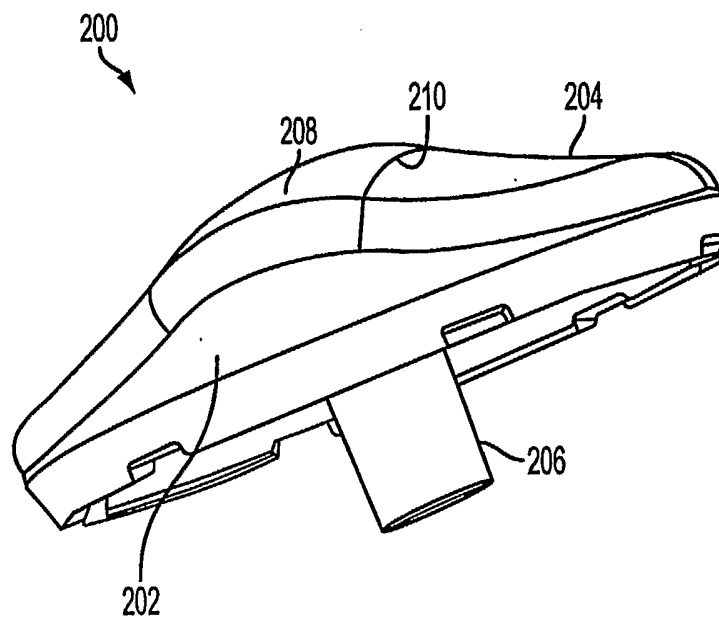

FIG. 8



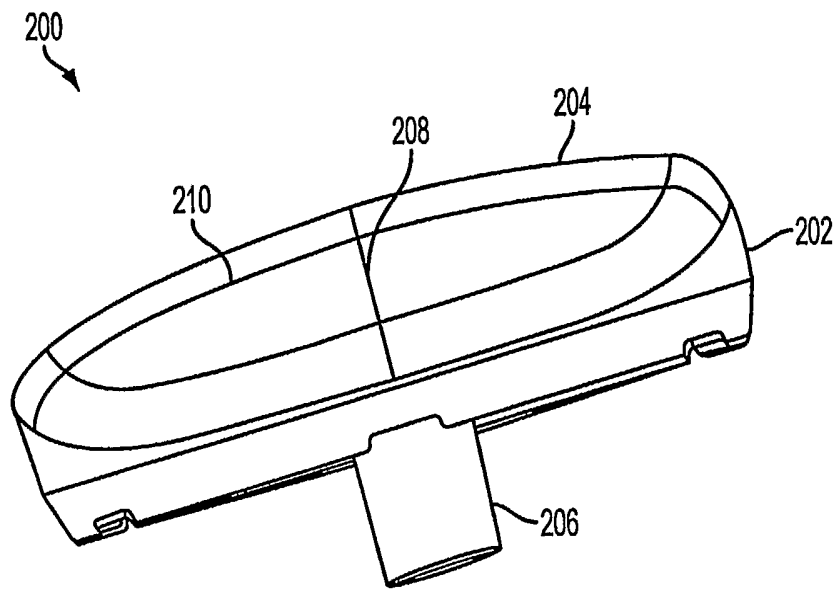

FIG. 9

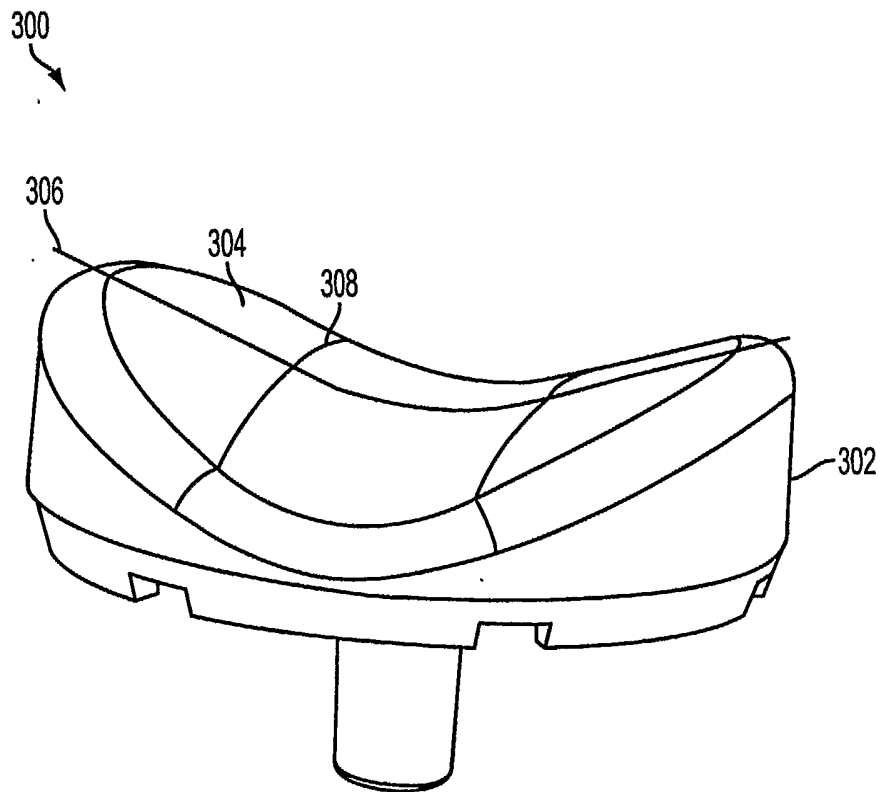

FIG. 10

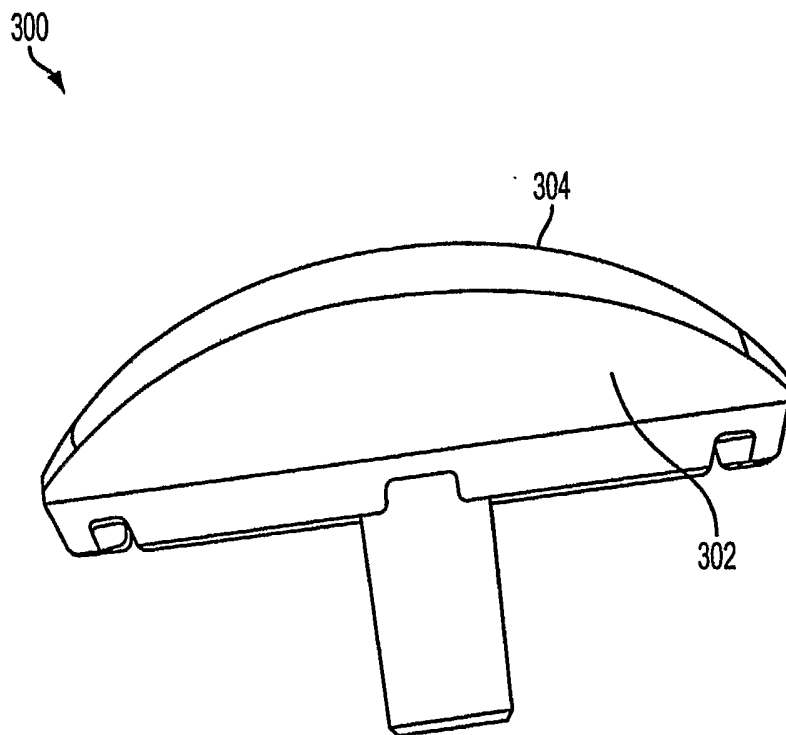

FIG. 11



FIG. 12