



(19) **United States**
(12) **Patent Application Publication**
Sung

(10) **Pub. No.: US 2015/0017884 A1**
(43) **Pub. Date: Jan. 15, 2015**

(54) **CMP PAD DRESSERS WITH HYBRIDIZED ABRASIVE SURFACE AND RELATED METHODS**

in-part of application No. 11/560,817, filed on Nov. 16, 2006, now Pat. No. 7,762,872.

(60) Provisional application No. 60/976,198, filed on Sep. 28, 2007.

(71) Applicant: **Chien-Min Sung**, Tansui (TW)

(72) Inventor: **Chien-Min Sung**, Tansui (TW)

(21) Appl. No.: **14/223,810**

(22) Filed: **Mar. 24, 2014**

Publication Classification

(51) **Int. Cl.**
B24B 53/017 (2006.01)

(52) **U.S. Cl.**
CPC **B24B 53/017** (2013.01)
USPC **451/56**

Related U.S. Application Data

(63) Continuation of application No. 14/149,691, filed on Jan. 7, 2014, now abandoned, which is a continuation-in-part of application No. 12/726,786, filed on Mar. 18, 2010, now Pat. No. 8,622,787, which is a continuation-in-part of application No. 12/255,823, filed on Oct. 22, 2008, now Pat. No. 8,393,934, which is a continuation-in-part of application No. 12/168,110, filed on Jul. 5, 2008, now Pat. No. 8,398,466, which is a continuation-

(57) **ABSTRACT**

The present invention provides CMP pad dressers and methods for dressing or conditioning CMP pads. In one aspect, a method for conditioning a CMP pad can include cutting the CMP pad with superabrasive cutting elements and controlling a degree of contact between the CMP pad and the cutting elements using control elements. The degree of contact is established through placement of the control elements relative to the cutting elements.

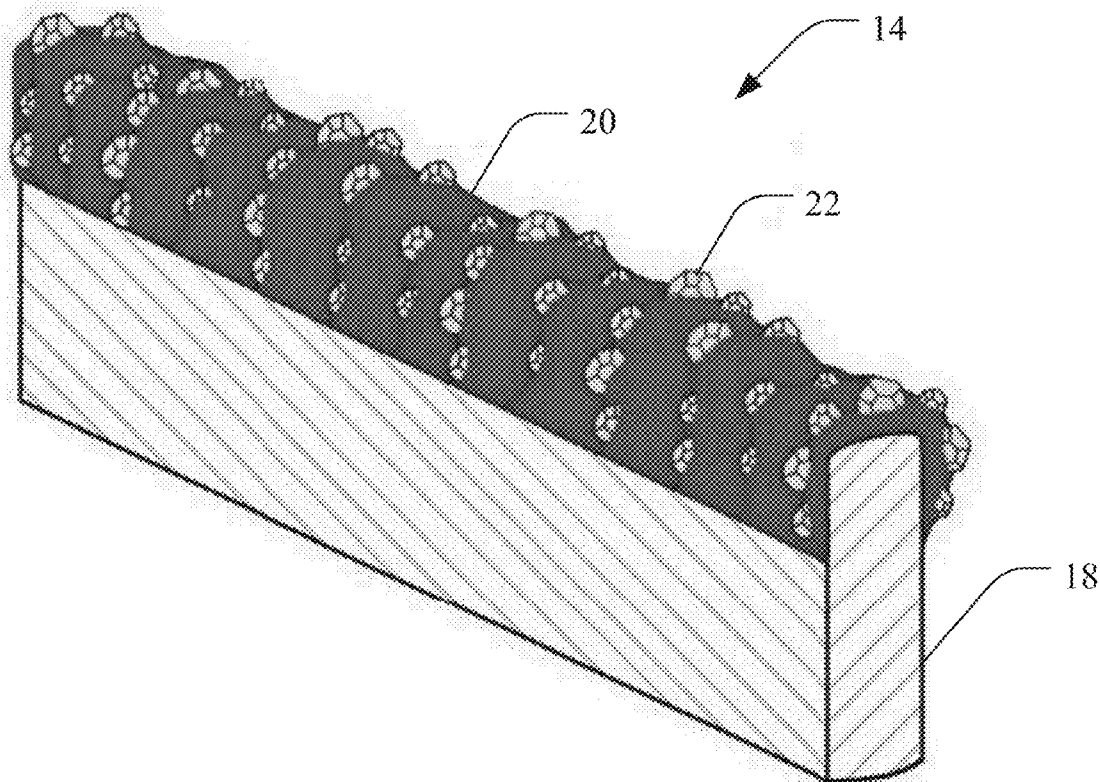

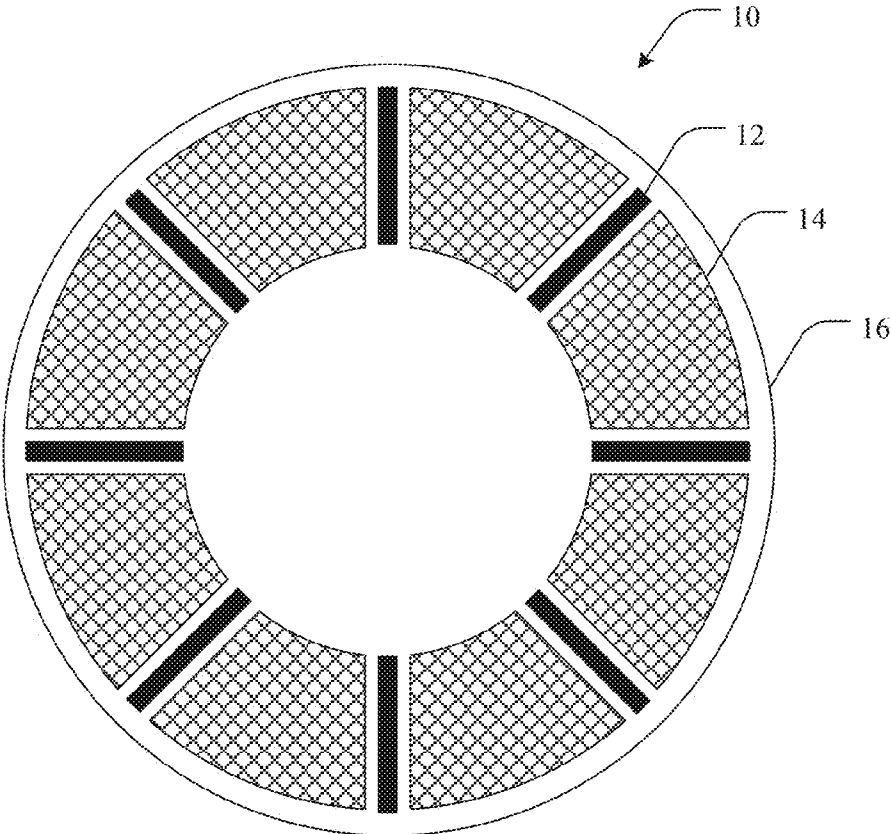

FIG. 1

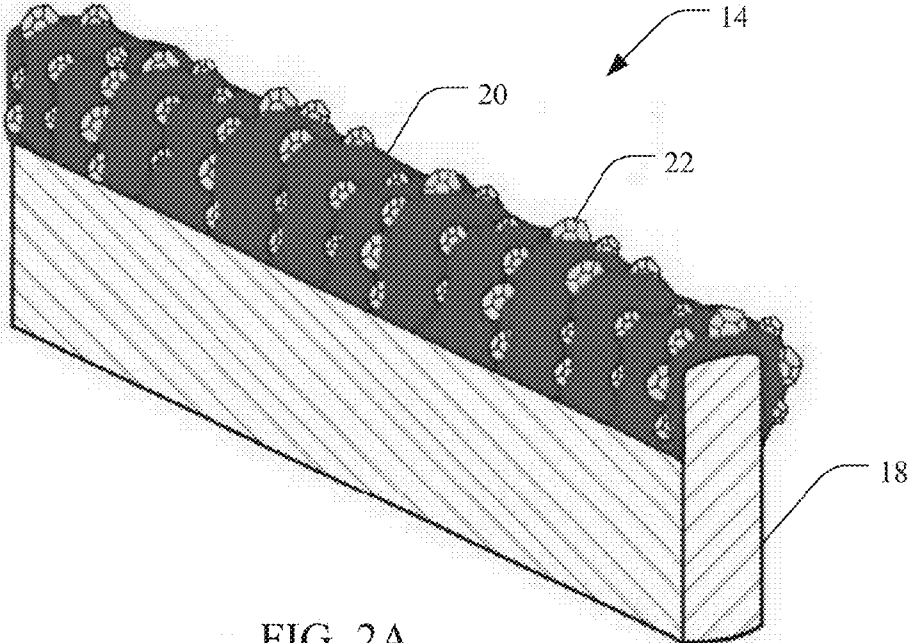

FIG. 2A

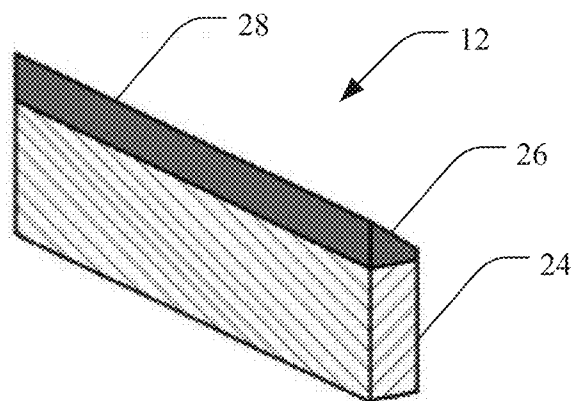

FIG. 2B

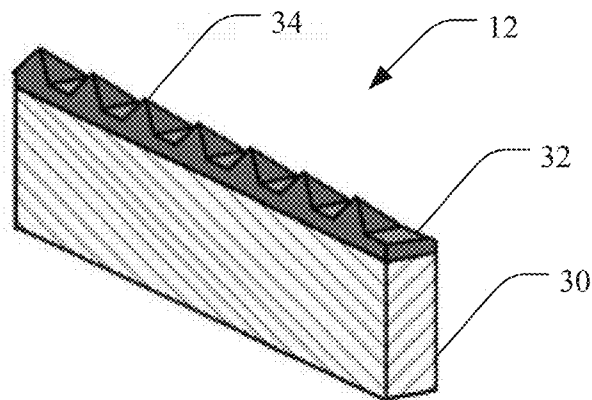

FIG. 2C

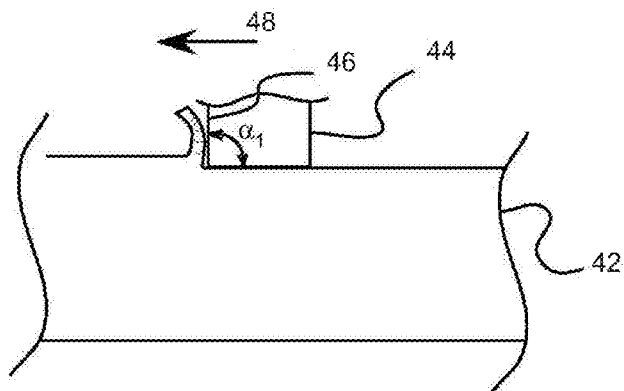

FIG. 3A

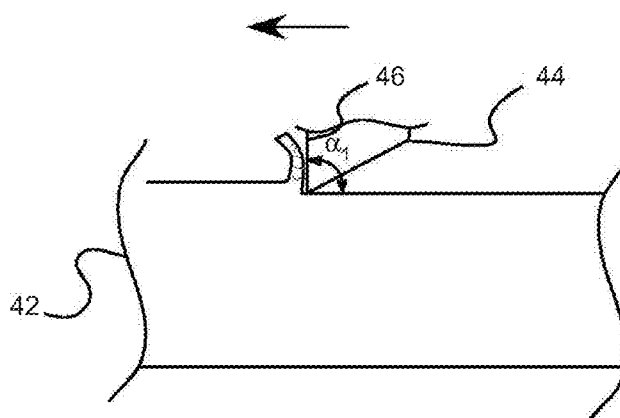

FIG. 3B

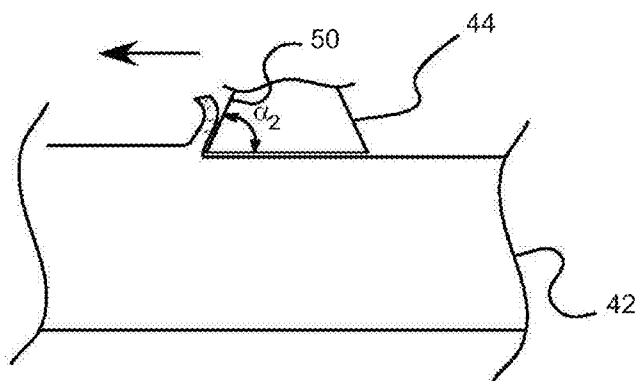
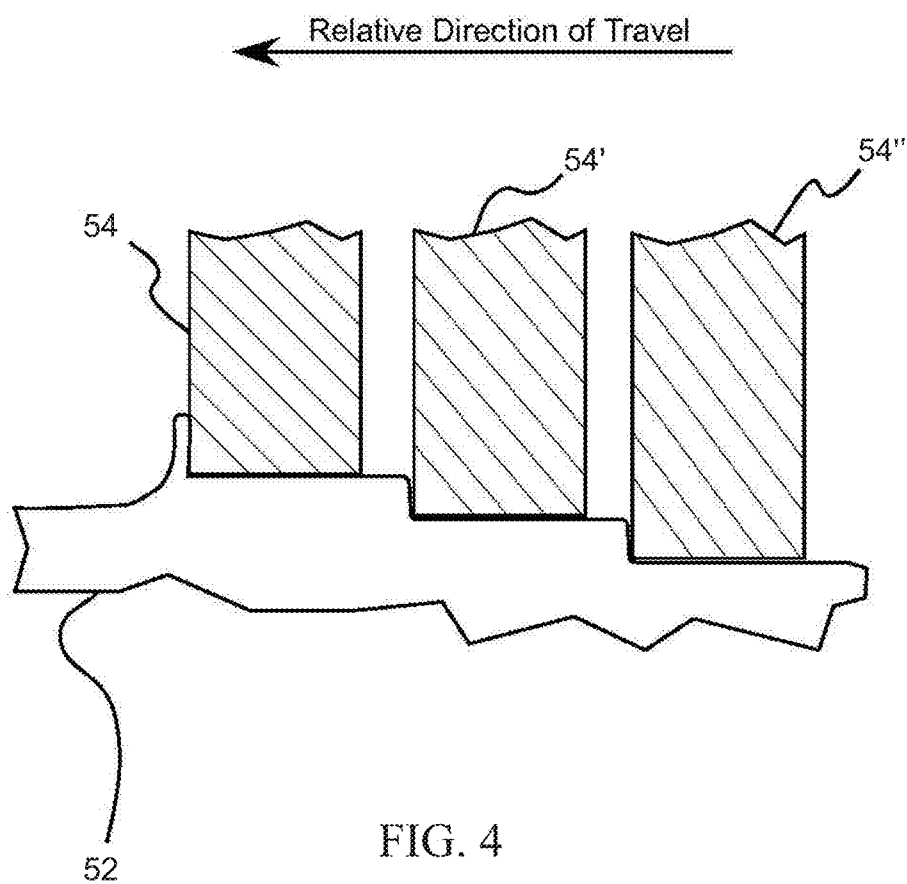

FIG. 3C



**CMP PAD DRESSERS WITH HYBRIDIZED
ABRASIVE SURFACE AND RELATED
METHODS**

PRIORITY CLAIM

[0001] This application is a continuation of U.S. patent application Ser. No. 14/149,691, filed Jan. 7, 2014, which is a continuation of U.S. patent application Ser. No. 12/726,786, filed Mar. 8, 2010, which is a continuation in part of copending U.S. patent application Ser. No. 12/255,823, filed on Oct. 22, 2008, which is a continuation in part of U.S. patent application Ser. No. 12/168,110, filed on Jul. 5, 2008, which claims the benefit of U.S. Provisional Patent Application Ser. No. 60/976,198, filed Sep. 28, 2007. U.S. patent application Ser. No. 12/168,110 is also a continuation-in-part of copending U.S. patent application Ser. No. 11/560,817, filed Nov. 16, 2006. All of the above applications are hereby incorporated herein by reference.

FIELD OF THE INVENTION

[0002] The present invention relates generally to CMP pad conditioners used to remove material from (e.g., smooth, polish, dress, etc.) CMP pads. Accordingly, the present invention involves the fields of chemistry, physics, and materials science.

BACKGROUND OF THE INVENTION

[0003] The semiconductor industry currently spends in excess of one billion U.S. Dollars each year manufacturing silicon wafers that must exhibit very flat and smooth surfaces. Known techniques to manufacture smooth and even-surfaced silicon wafers are plentiful. The most common of these involves the process known as Chemical Mechanical Polishing (CMP) which includes the use of a polishing pad in combination with an abrasive slurry. Of central importance in all CMP processes is the attainment of high performance levels in aspects such as uniformity of polished wafer, smoothness of the IC circuitry, removal rate for productivity, longevity of consumables for CMP economics, etc.

SUMMARY OF THE INVENTION

[0004] The present invention provides CMP pad dressers and methods for dressing or conditioning CMP pads. In one aspect, for example, a method for conditioning a CMP pad can include cutting the CMP pad with superabrasive cutting elements and controlling a degree of contact between the CMP pad and the cutting elements using control elements. In this case, the degree of contact is established through placement of the control elements relative to the cutting elements.

[0005] The degree of contact can be controlled using a variety of placements of the control elements relative to the cutting elements. In one aspect, for example, controlling the degree of contact includes alternating regions of cutting elements with regions of control elements. In another aspect, the degree of contact can be controlled by locating the regions of control elements at a distance from the regions of cutting elements to establish the degree of contact in relation to material characteristics of the CMP pad. This can be accomplished in an alternating pattern or a non-alternating pattern. In yet another aspect, controlling the degree of contact includes locating the regions of control elements at a distance

from the regions of cutting elements to affect a degree of compression of the CMP pad along a leading edge of the regions of cutting elements.

[0006] In another aspect of the present invention, a CMP pad dresser is provided. Such a dresser can include an organic matrix and a plurality of cutting elements partially embedded directly in the organic matrix, where the cutting elements are arranged into a plurality of distinct cutting element regions. The dresser can also include a plurality of control elements partially embedded directly in the organic matrix, where the control elements are arranged into a plurality of distinct control element regions. Furthermore, the cutting element regions and the control element regions are positioned in an alternating pattern, and the control element regions are spaced relative to the cutting element regions to control a degree of contact between the cutting elements and a CMP pad. In some aspects, the organic matrix is coupled to a CMP pad dresser support substrate.

[0007] In one aspect, each of the plurality of cutting elements and each of the plurality of control elements includes a CMP pad contact region, and wherein the contact regions are leveled relative to one another such that no contact region protrudes above another contact region by more than about 30 microns.

[0008] There has thus been outlined, rather broadly, various features of the invention so that the detailed description thereof that follows may be better understood, and so that the present contribution to the art may be better appreciated. Other features of the present invention will become clearer from the following detailed description of the invention, taken with any accompanying or following claims, or may be learned by the practice of the invention.

BRIEF DESCRIPTION OF THE DRAWINGS

[0009] FIG. 1 is a schematic, top plan view of an exemplary pad conditioner in accordance with an embodiment of the invention;

[0010] FIG. 2A is an enlarged, perspective schematic view of an exemplary abrasive segment that can be used in the pad conditioner of FIG. 1;

[0011] FIG. 2B is an enlarged, perspective schematic view of an exemplary abrasive segment that can be used in the pad conditioner of FIG. 1;

[0012] FIG. 2C is an enlarged, perspective schematic view of an exemplary abrasive segment that can be used in the pad conditioner of FIG. 1;

[0013] FIG. 3A is a side, schematic view of an abrasive segment having a cutting face shown removing material from a section of a CMP pad;

[0014] FIG. 3B is a side, schematic view of an abrasive segment having a differently configured cutting face shown removing material from a section of a CMP pad;

[0015] FIG. 3C is a side, schematic view of an abrasive segment having a differently configured cutting face shown removing material from a section of a CMP pad; and

[0016] FIG. 4 is a schematic, side view of a portion of a CMP pad dresser having a series of abrasive segments arranged at varying elevations relative to one another.

[0017] It will be understood that the above figures are merely for illustrative purposes in furthering an understanding of the invention. Further, the figures may not be drawn to scale, thus dimensions, particle sizes, and other aspects may, and generally are, exaggerated to make illustrations thereof clearer. For example, an abrasive layer is illustrated in some

of the figures as including a plurality of abrasive particles: however, many of the specific embodiments disclosed herein do not necessarily include abrasive particles. Therefore, it will be appreciated that departure can and likely will be made from the specific dimensions and aspects shown in the figures in order to produce the pad conditioners of the present invention.

DETAILED DESCRIPTION

[0018] Before the present invention is disclosed and described, it is to be understood that this invention is not limited to the particular structures, process steps, or materials disclosed herein, but is extended to equivalents thereof as would be recognized by those ordinarily skilled in the relevant arts. It should also be understood that terminology employed herein is used for the purpose of describing particular embodiments only and is not intended to be limiting.

[0019] It should be noted that, as used in this specification and any appended or following claims, the singular forms “a,” “an” and “the” include plural referents unless the context clearly dictates otherwise. Thus, for example, reference to “an abrasive segment” can include one or more of such segments.

DEFINITIONS

[0020] In describing and claiming the present invention, the following terminology will be used in accordance with the definitions set forth below.

[0021] All mesh sizes that may be referred to herein are U.S. mesh sizes unless otherwise indicated. Further, mesh sizes are generally understood to indicate an average mesh size of a given collection of particles since each particle within a particular “mesh size” may actually vary over a small distribution of sizes.

[0022] As used herein, the terms “pad conditioner” and “pad dresser” can be used interchangeably, and refer to a tool used to condition or dress a pad, such as a CMP pad.

[0023] As used herein, a pad conditioner “substrate” or “support substrate” refers to a portion of a pad conditioner that supports an organic matrix, and to which abrasive materials, segment blanks that carry abrasive materials, cutting elements, control elements, etc. may be affixed. Substrates useful in the present invention may be of a variety of shapes, thicknesses, or materials that are capable of supporting an organic matrix in a manner that is sufficient to provide a pad conditioner useful for its intended purpose. Substrates may be of a solid material, a powdered material that becomes solid when processed, or a flexible material. Examples of typical substrate materials include without limitation, metals, metal alloys, ceramics, relatively hard polymers or other organic materials, glasses, and mixtures or combinations thereof.

[0024] As used herein, “segment blank” refers to a structure similar in many respects to the pad conditioner substrates defined above. Segment blanks are utilized in the present invention to carry abrasive layers: attachment of the abrasive layers to the pad conditioner substrates is typically achieved by way of attaching the segment blanks to the pad conditioner substrates. It is important to note that a variety of techniques of attaching the segment blanks to the substrates, and a variety of techniques of attaching the abrasive layers to the segment blanks, are discussed herein. It is to be understood that all of these various attachment mechanisms can be used interchangeably herein: that is, if a method of attaching a segment

blank to a substrate is discussed herein, the method of attachment discussed can also be used to attach an abrasive layer to a segment blank. For any particular CMP pad dresser being discussed, however, it is understood that attachment methods of the abrasive layers to the segment blanks can differ from, or can be the same as, the method used to attach the segment blanks to the pad conditioner substrate.

[0025] As used herein, “geometric configuration” refers to a shape that is capable of being described in readily understood and recognized mathematical terms. Examples of shapes qualifying as “geometric configurations” include, without limitation, cubic shapes, polyhedral (including regular polyhedral) shapes, triangular shapes (including equilateral triangles, isosceles triangles and three-dimensional triangular shapes), pyramidal shapes, spheres, rectangles, “pie” shapes, wedge shapes, octagonal shapes, circles, etc.

[0026] As used herein, “vapor deposition” refers to a process of depositing materials on a substrate through the vapor phase. Vapor deposition processes can include any process such as, but not limited to, chemical vapor deposition (CVD) and physical vapor deposition (PVD). A wide variety of variations of each vapor deposition method can be performed by those skilled in the art. Examples of vapor deposition methods include hot filament CVD, rf-CVD, laser CVD (LCVD), metal-organic CVD (MOCVD), sputtering, thermal evaporation PVD, ionized metal PVD (IMPVD), electron beam PVD (EBPVD), reactive PVD, and the like.

[0027] As used herein, “abrasive profile” is to be understood to refer to a shape, configuration, or a space defined by abrasive materials that can be used to remove material from or reorganize material on a CMP pad. Examples of abrasive profiles include, without limitation, rectangular shapes, tapering rectangular shapes, truncated wedge shapes, wedge shapes, a “saw tooth” profile and the like. In some embodiments, the abrasive profile exhibited by abrasive segments of the present invention will be apparent when viewed through a plane in which the CMP pad will be oriented during removal of material from the CMP pad.

[0028] As used herein, an “abrading surface or point” may be used to refer to a surface, edge, face, point or peak of an abrasive segment or cutting element that contacts and removes material from a CMP pad. Generally speaking, the abrading surface or point is the portion of the abrasive segment that first contacts the CMP pad as the abrasive segment or cutting element and the CMP pad are brought into contact with one another.

[0029] As used herein, “superhard” may be used to refer to any crystalline, or polycrystalline material, or mixture of such materials which has a Mohr’s hardness of about 8 or greater. In some aspects, the Mohr’s hardness may be about 9.5 or greater. Such materials include but are not limited to diamond, polycrystalline diamond (PCD), cubic boron nitride (cBN), polycrystalline cubic boron nitride (PcBN), corundum and sapphire, as well as other superhard materials known to those skilled in the art. Superhard materials may be incorporated into the present invention in a variety of forms including particles, grits, films, layers, pieces, segments, etc. In some cases, the superhard materials of the present invention are in the form of polycrystalline superhard materials, such as PCD and PcBN materials.

[0030] As used herein, “organic material” refers to a semisolid or solid complex or mix of organic compounds. “Organic material layer” and “organic matrix” may be used interchangeably, and refer to a layer or mass of a semisolid or

solid complex or mix of organic compounds, including resins, polymers, gums, etc. The organic material can be a polymer or copolymer formed from the polymerization of one or more monomers. In some cases, such organic material can be adhesive.

[0031] As used herein, the process of “brazing” is intended to refer to the creation of chemical bonds between the carbon atoms of the superabrasive particles/materials and the braze material. Further, “chemical bond” means a covalent bond, such as a carbide or boride bond, rather than mechanical or weaker inter-atom attractive forces. Thus, when “brazing” is used in connection with superabrasive particles a true chemical bond is being formed. However, when “brazing” is used in connection with metal to metal bonding the term is used in the more traditional sense of a metallurgical bond. Therefore, brazing of a superabrasive segment to a tool body does not necessarily require the presence of a carbide former.

[0032] As used herein, an “abrasive layer” describes a variety of structures capable of removing (e.g., cutting, polishing, scraping) material from a CMP pad. An abrasive layer can include a mass having several cutting points, ridges or mesas formed thereon or therein. It is notable that such cutting points, ridges or mesas may be from a multiplicity of protrusions or asperities included in the mass. Furthermore, an abrasive layer can include a plurality of individual abrasive particles that may have only one cutting point, ridge or mesa formed thereon or therein. An abrasive layer can also include composite masses, such as PCD pieces, segment or blanks, either individually comprising the abrasive layer or collectively comprising the abrasive layer.

[0033] As used herein, “metallic” includes any type of metal, metal alloy, or mixture thereof, and specifically includes but is not limited to steel, iron, and stainless steel.

[0034] As used herein, “material characteristic” refers to the physical and/or chemical properties of a CMP pad. These can include properties such as molecular makeup, compressibility, softness, pore density, and the like.

[0035] As used herein, “cutting element” refers to an element of a CMP pad dresser that is intended to cut, abrade, remove, or otherwise reorganize the material of a CMP pad for the purpose of conditioning or dressing. Cutting elements can function using a point, edge, face, or any other region of the cutting element that is capable of conditioning or dressing the CMP pad. Cutting elements should be considered to include individual cutters such as diamond particles, as well as segment blanks that contain multiple cutters provided the context allows.

[0036] As used herein, “control element” refers to an element of a CMP pad dresser that is intended to control the degree of contact between the CMP pad dresser and a CMP pad, or portions of the dresser, such as cutting elements and the CMP pad. Thus, in some aspects control elements compress the CMP pad to a degree that alters the contact between the cutting elements and the CMP pad. It should be noted that control elements can be made of abrasive materials, and as such can function to dress or condition the CMP pad during compression. However, in such cases, the CMP pad is primarily conditioned by the cutting elements. As such, the use of the term “abrasive” herein should also include control elements when appropriate.

[0037] As used herein, the term “substantially” refers to the complete or nearly complete extent or degree of an action, characteristic, property, state, structure, item, or result. As an arbitrary example, when two or more objects are referred to as

being spaced a “substantially” constant distance from one another, it is understood that the two or more objects are spaced a completely unchanging distance from one another, or so nearly an unchanging distance from one another that a typical person would be unable to appreciate the difference. The exact allowable degree of deviation from absolute completeness may in some cases depend upon the specific context. However, generally speaking the nearness of completion will be so as to have the same overall result as if absolute and total completion were obtained.

[0038] The use of “substantially” is equally applicable when used in a negative connotation to refer to the complete or near complete lack of an action, characteristic, property, state, structure, item, or result. As an arbitrary example, a cavity that is “substantially free of” foreign matter would either completely lack any foreign matter, or so nearly completely lack foreign matter that the effect would be the same as if it completely lacked foreign matter. In other words, a cavity that is “substantially free of” foreign matter may still actually contain minute portions of foreign matter so long as there is no measurable effect upon the cavity as a result thereof.

[0039] As used herein, a plurality of items, structural elements, compositional elements, and/or materials may be presented in a common list for convenience. However, these lists should be construed as though each member of the list is individually identified as a separate and unique member. Thus, no individual member of such list should be construed as a de facto equivalent of any other member of the same list solely based on their presentation in a common group without indications to the contrary.

[0040] Concentrations, amounts, particle sizes, volumes, and other numerical data may be expressed or presented herein in a range format. It is to be understood that such a range format is used merely for convenience and brevity and thus should be interpreted flexibly to include not only the numerical values explicitly recited as the limits of the range, but also to include all the individual numerical values or sub-ranges encompassed within that range as if each numerical value and sub-range is explicitly recited.

[0041] As an illustration, a numerical range of “about 1 micrometer to about 5 micrometers” should be interpreted to include not only the explicitly recited values of about 1 micrometer to about 5 micrometers, but also include individual values and sub-ranges within the indicated range. Thus, included in this numerical range are individual values such as 2, 3, and 4 and sub-ranges such as from 1-3, from 2-4, and from 3-5, etc. This same principle applies to ranges reciting only one numerical value. Furthermore, such an interpretation should apply regardless of the breadth of the range or the characteristics being described.

The Invention

[0042] The present invention generally provides pad conditioners and associated methods that can be utilized in conditioning (e.g., smoothing, polishing, dressing) or otherwise affecting a CMP pad to remove material from the CMP pad in order to provide a finished, smooth and/or flat surface to the pad. Pad conditioners of the present invention can be advantageously utilized, for example, in dressing CMP pads that are used in polishing, finishing or otherwise affecting silicon wafers.

[0043] It has now been discovered that CMP pad dressing can be improved by alternating cutting and furrowing in the

same dressing operation. This can be accomplished by utilizing a CMP pad dresser having a dressing surface containing blade abrasive segments and particle abrasive segments arranged in an alternating fashion. Thus as the CMP pad dresser moves relative to the CMP pad, the surface of the CMP pad is alternately cut with the blade abrasive segments and furrowed with the particle abrasive segments.

[0044] It has also been discovered that CMP pad dressing can be improved by utilizing different CMP pad dresser elements in an alternating fashion to control the degree of contact between the CMP pad and portions of the CMP pad dresser that are cutting the pad. By positioning control elements relative to cutting elements, the degree of contact between the CMP pad and the cutting elements can be controlled, thus increasing the efficiency and/or quality of the dressing action. In a circular tool such as a CMP pad dresser, an alternating arrangement of regions of cutting elements and regions of control elements can be used.

[0045] For example, by alternating regions of cutting elements each having a sharp abrading surface and regions of control elements each having a blocky or dull abrading surface, compression of the CMP pad by the sharper cutting elements can be minimized. As an explanatory example, a CMP pad dresser having cutting elements spaced far apart requires more downward compression into the pad to facilitate cutting as compared to a CMP pad dresser having cutting elements closer together, due in part to the upwelling of CMP pad material between the cutting elements. A CMP pad dresser having cutting elements positioned more closely together facilitates the cutting of the pad with less compression, thus reducing damage to the pad from overcutting.

[0046] By alternating regions of control elements in between regions of cutting elements, the compression of the CMP pad during dressing can be controlled. Positioning the control elements further away from the cutting elements causes the degree of contact and thus the compression of the pad by the cutting elements to be increased. This increase in compression can result in a more aggressive dressing by the cutting elements. Positioning the control elements closer to the cutting elements reduces the upwelling of the pad material between the cutting elements, thus decreasing the degree of contact and the compression of the pad. Such a configuration can be particularly effective when using CMP pads made from the soft materials required for many current delicate polishing procedures. Such soft materials can be more effectively dressed using lower dresser compression due to the material characteristics of the CMP pad, which can experience high degrees of deformation when pressure from a dresser is applied.

[0047] Additionally, the control elements can be spaced from the cutting elements at a distance that allows the CMP pad to be cut as it is being expanded from a compressed state. More specifically, as the CMP pad is relaxing from the compressed state caused by the control elements a slope is formed in the pad. The abrading surfaces of the cutting elements can engage the pad along this slope and thus cut the pad with less compression. This can minimize the extent of penetration of the bodies of the cutting elements into the pad, thus minimizing drag and reducing tearing the CMP pad material.

[0048] While these techniques can be used to dress a variety of CMP pad materials, they can be particularly beneficial for dressing pads made of soft CMP pad materials. A variety of soft materials are contemplated. In one aspect, for example, the soft material can be about as soft as a conventional poly-

urethane pad. In another aspect, the soft material can be softer than a conventional polyurethane pad. In yet another aspect, the soft material can be at least about 10% softer than a conventional polyurethane pad. In a further aspect, the soft material can be at least about 25% softer than a conventional polyurethane pad. In yet a further aspect, the soft material can be at least about 50% softer than a conventional polyurethane pad.

[0049] As is shown in FIG. 1, a CMP pad conditioner **10** is provided. In one aspect, the pad conditioner can include a plurality of distinct cutting element regions **12** and a plurality of distinct control element regions **14** positioned in an alternating arrangement on a support substrate **16**. In one specific aspect, the cutting element regions can be cutting elements disposed directly in an organic matrix on the pad conditioner substrate and the control element region can be blocky control elements disposed directly in the same organic matrix. The control element regions are thus positioned and spaced relative to the cutting element regions to control the degree of contact between the sharp cutting elements and the CMP pad. In another aspect, the pad conditioner can include a plurality of blade abrasive segments and a plurality of particle abrasive segments positioned in an alternating arrangement on a pad conditioner substrate.

[0050] Numerous alternating arrangements are contemplated, including, without limitation, the radial arrangement shown in FIG. 1. It is noted that blade abrasive segments, particle abrasive segments, cutting elements, and control elements can be referred to herein collectively as the “abrasive elements” or “abrasive segments” for the sake of simplicity. Similarly, the term “abrasive layer” may be used to refer collectively to any abrasive material, segment, or element for simplicity sake.

[0051] The CMP pad conditioner can also include multiple annular rings of abrasive segments, cutting elements, and/or control elements, as opposed to the single annular ring shown in FIG. 1. Furthermore, it should be noted that regions or segments would also include arrangements where grouped multiples of one or more regions or segments were included in the pattern. For example, in one aspect the pattern of abrasive elements can include two or more blade abrasive segments alternating between each pair of particle abrasive segments. In another aspect the pattern of abrasive elements can include three or more blade abrasive segments alternating between each pair of particle abrasive segments. Additionally, in some aspects, multiple particle abrasive segments can be grouped and alternated in between blade abrasive segments or segment groups.

[0052] Various configurations of cutting elements and control elements are contemplated. As such, any configuration of elements whereby control elements function to control the degree of contact and thus the compression of the cutting elements during conditioning of a CMP pad should be considered to be within the present scope. For example, in one aspect, the cutting elements can be blade elements and the control elements can be particle elements having a dull edge or face oriented toward the pad. In this case, the placement of the dull control elements relative to the blade elements can control the compression and thus the cutting of the pad by the blade elements. In another aspect, the cutting elements can be blade elements having a sharp cutting edge oriented toward the pad and the control elements can be blade elements having a dull edge as compared to the blade cutting elements. Thus the duller blade elements compress the CMP pad and control

the degree of contact between the sharper blade elements and the CMP pad. In yet another aspect, the cutting elements can be particle elements having a sharp point or edge oriented toward the pad and the control elements can be particle elements having a dull edge or point oriented toward the pad.

[0053] A variety of materials are contemplated for use as control and cutting elements. Any superabrasive known that can be utilized in a CMP pad dresser should be considered to be within the present scope. Non-limiting examples of such materials include diamond materials, nitride materials, ceramics, and the like. In one aspect, the cutting elements and control elements include diamond materials. Such diamond materials can include natural or synthetic diamond, single crystal, polycrystalline, and the like. In another aspect, the cutting elements and control elements include cubic boron nitride materials.

[0054] The pad conditioner substrate **16** can vary according to the applications for which the pad conditioner is designed, but in one aspect includes a face on which the organic matrix can be affixed to allow the pad conditioner to be used to grind, plane, cut or otherwise remove material from a CMP pad (not shown). The abrasive elements or segments can be permanently fixed to the pad conditioner **16** in an orientation that enables removal of material from the CMP pad as the pad conditioner and the pad are moved relative to one another. For example, as has been described and as shown in FIG. 1, the regions **12** and **14** are arranged radially along an edge of a substantially circular pad conditioner substrate. Such an arrangement has been found well suited to remove material from a CMP pad (while “dressing” the pad) by rotating the pad conditioner substrate relative to the pad.

[0055] The present invention provides a number of advantages over conventional devices. For embodiments using abrasive segments, one such advantage lies in the ability to customize methods of attachment of the abrasive layer to the segment blank independently of methods of attachment of the segment blank or blanks to the pad conditioner substrate. For example, as various attachment methods may involve very high temperatures and/or pressures, very demanding environmental conditions, or simply are very labor intensive when attempted with pad conditioners of large or complex surface areas, performing the attachment method on distinct, easily handled segment blanks can improve costs, efficiencies and integrities of the attachment process. Also, leveling of the components of the abrasive layer on each segment blank can be performed more easily when done in discrete, relatively small lots. The resulting plurality of abrasive segments can likewise be more easily positioned, leveled, spaced, oriented, etc., across the face of the pad conditioner substrate after the abrasive layer is individually attached to each of the abrasive segments.

[0056] In addition, by obtaining a plurality of abrasive segments, each with an abrasive layer already attached thereto, an abrasive pattern across the face of the pad conditioner substrate can be designed to optimize various conditioning procedures. For example, the spacing between adjacent abrasive segments can be carefully selected to aid in, or better control, the flow of various fluids (e.g., slurry) around and through the abrasive segments to increase the efficacy and efficiency of the material removing process. Also, as shown in FIG. 1, segment blanks having differing abrasive profiles (e.g., different sizes, shapes, abrasive aggressiveness, etc.) can be used on a single substrate, to enable customization of an abrading profile of the pad conditioner as a whole. The

same principles apply to CMP pad dressers having cutting elements and control elements embedded in an organic matrix.

[0057] Numerous configurations of abrasive segments are contemplated, depending on the nature of the CMP pad and the desired dressing characteristics. In one aspect, as exemplified in FIG. 2A, each particle abrasive segment **14** can include a segment blank **18** and an abrasive layer **20** attached to the segment blank. The abrasive layer **20** can include a superhard abrasive material: in the exemplary embodiment of FIG. 2A, the superhard abrasive material includes a plurality of superabrasive particles **22**.

[0058] In another aspect, as exemplified in FIG. 2B, a blade abrasive segment **12** can include a segment blank **24** and an abrasive layer **26** attached to the segment blank as an elongate cutting blade. It should be noted that these blades can also be used as cutting elements or control elements that are disposed directly into the organic matrix. These blades can include a significantly longer length than a width, similar to blade of a conventional knife. In this aspect of the invention, the blade can be used to cut, scrape, carve, or control a relatively wide swath of area of the CMP pad. The abrasive layer **26** of the blade abrasive element includes a continuous cutting edge **28**. In another aspect, as exemplified in FIG. 2C, a blade abrasive element **12** can include a segment blank **30** and an abrasive layer **32** attached to the segment blank as an elongate cutting blade. Additionally, in some aspect the abrasive layer can be disposed directly in the organic matrix. In contrast to the aspect shown in FIG. 2B, the abrasive layer **32** of the blade abrasive element includes a series of cutting teeth **34** formed in the abrasive layer. Further details regarding the construction and use of abrasive segments and/or blades can be found in U.S. Provisional Patent Application Ser. No. 60/987,687, filed Nov. 13, 2007, which is hereby incorporated herein by reference.

[0059] The cutting action of the blade elements is now shown to be advantageous to the dressing of a CMP pad. As is shown in FIGS. 3A-3C, for example, an embodiment is shown which aids in addressing issues relating to plastic deformation of a CMP pad (shown by example and in sectioned view at **42**). As has been described, this embodiment reduces the downward force required between the pad conditioner and the CMP pad. As a result, the CMP pad is left with a conditioned surface that is much more smooth and level than that obtained using conventional methods.

[0060] The conditioner shown in FIGS. 3A-3C can include abrasive layer **44** (only a section of which is shown). The abrasive layer can include a cutting face **46** angled at 90 degrees or less relative to a finished surface to be applied to the CMP pad (e.g., relative to movement of the cutting face away from the finished surface—sometimes referred to as a positive cutting angle). The face **46** of the abrasive layer **44** can be oriented such that relative movement of the pad conditioner (in the direction indicated at **48** in FIG. 3A) and the CMP pad **42** results in clean removal of material from the CMP pad with the cutting face to thereby condition the CMP pad.

[0061] By angling the cutting face **46** at 90 degrees or less, relative to a finished surface to be applied to the pad **42**, the dressing process can cleanly shave a layer of pad material from the pad. The resultant surface applied to the pad can be safely used in the CMP process without damaging expensive silicon wafers. The present pad conditioners can be used to shave even a very shallow, thin layer of material from the pad

and leave behind a clean, smooth and even finished surface on the pad. This technique can be used to remove thin layers of glaze that can be formed on the surface of the CMP pad.

[0062] The cutting face **46** is shown in FIGS. **3A** and **3B** oriented at an angle \square_1 of about 90 degrees relative to the finished surface to be applied to the CMP pad. Cutting face **50** of FIG. **3C** is oriented at angle \square_2 that is less than 90 degrees relative to the finished surface to be applied to the CMP pad, on the order of about 60 degrees. The cutting faces can be oriented at a variety of angles, and in one embodiment vary from about 45 degrees to about 90 degrees relative to the finished surface of the CMP pad. It has been found that reducing the angle creates an even sharper cutting interface between the cutting element and the pad.

[0063] Those embodiments illustrated in the figures that include angled cutting faces each include a cutting face that is formed having the corresponding angle. In some embodiments, however, it is to be understood that a relatively normal (e.g., 90 degree) cutting face can be utilized, except that the abrasive segment on which the cutting face is formed can be "tilted" when attached to the substrate. In other words, the cutting face is not angled relative to the abrasive segment, rather angling of the abrasive segment results in angling of the cutting face. In this manner, an angled cutting face is provided without requiring that the referenced angle be formed on (or in) the abrasive segment.

[0064] Additional and varying abrasive segments, cutting elements, and control elements for use in the present invention are also contemplated. For example, use is contemplated of the various cutting elements/abrasive segments detailed in U.S. patent application Ser. No. 11/357,713, filed Feb. 17, 2006, which is hereby incorporated herein by reference. In addition, formation of the abrasive layer on the segment blanks can be accomplished by way of a variety of techniques, including but not limited to vapor deposition techniques similar to those outlined in U.S. patent application Ser. No. 11/512,755, filed Aug. 29, 2006, which is hereby incorporated herein by reference. In addition, the abrasive segments can be formed utilizing ceramic components (as either or both the segment blank and/or the abrasive layer); electroplating techniques, etc.

[0065] In the embodiment illustrated in FIG. **4**, a series of abrasive layers **54**, **54'** and **54''** is provided, each of which includes a cutting tip oriented at a different elevation. In this aspect of the invention, the leading abrasive segment or cutting element (of which abrasive layer **54** forms a part) is generally at a relatively higher elevation than are trailing abrasive layers **54'** and **54''**, as the trailing layers would not otherwise contact pad material remaining after the leading blade has passed. The abrasive segments having abrasive layers **54**, **54'** and **54''** can be formed in a variety of manners and in a variety of shapes, sizes and configurations, as detailed, for example, in U.S. Provisional Patent Application Serial 60/988,643, filed Nov. 16, 2007, which is hereby incorporated herein by reference in its entirety. This embodiment can utilize intentionally cascaded cutting elements to achieve a desired abrading affect.

[0066] Numerous materials and methods of manufacturing are contemplated for constructing the CMP pad conditioners of the present invention. It should be noted that the materials and techniques disclosed herein are exemplary, and additional materials and techniques can be utilized without departing from the present scope.

[0067] The various segment blanks shown and discussed herein can be formed from a variety of materials, including, without limitation, metallic materials such as aluminum, copper, steel, metal alloys, etc., ceramic materials, glasses, polymers, composite materials, etc. Generally speaking, virtually any material to which an abrasive segment can be attached thereto will suffice.

[0068] In some embodiments, the material of the segment blank can be chosen to provide superior results during the process of attaching the abrasive layer thereto. The abrasive layer can be attached to the segment blank in a variety of manners, including epoxy bonding methods (e.g., organic bonding methods), metal brazing, sintering, electrodeposition, etc. The material of the segment blank can thus be chosen based upon the attachment process anticipated. For example, a segment blank formed partially or fully from nickel, or stainless steel, can be utilized in some processes involving brazing and/or sintering. Also, ceramic or metallic materials might be utilized in organic attachment methods.

[0069] Various embodiments of the invention employ various methods of attachment of the abrasive layer to the segment blank, or the cutting and control elements to the support substrate. In one aspect, an organic material layer or matrix can be deposited on the segment blank or support substrate, and one or more abrasive particles, chips, segments, elements, etc., can be fixed thereto by way of the organic material layer or matrix. Examples of suitable organic matrix materials include, without limitation, amino resins, acrylate resins, alkyd resins, polyester resins, polyamide resins, polyimide resins, polyurethane resins, phenolic resins, phenolic/latex resins, epoxy resins, isocyanate resins, isocyanurate resins, polysiloxane resins, reactive vinyl resins, polyethylene resins, polypropylene resins, polystyrene resins, phenoxy resins, perylene resins, polysulfone resins, acrylonitrile-butadiene-styrene resins, acrylic resins, polycarbonate resins, polyimide resins, and mixtures thereof.

[0070] So-called "reverse casting" methods can be used to accurately and controllably orient and attach the abrasive materials or elements onto a segment blank (and to orient and attach the segment blanks or the cutting elements and control elements to the pad conditioner support substrate). Such methods can include initially securing a superabrasive material, e.g., a plurality of superabrasive particles, to a substrate using a "mask" material. The portions of the particles protruding from the mask material can then be attached to a substrate, such as a segment blank, using the methods discussed herein, after which (or during which), the masking material can be removed.

[0071] Suitable reverse casting methods can be found in various patents and patent applications to the present inventor, including U.S. Patent Application Ser. No. 60/992,966, filed Dec. 6, 2007; U.S. patent application Ser. No. 11/804,221, filed May 16, 2007; and U.S. patent application Ser. No. 11/805,549, filed May 22, 2007, each of which is hereby incorporated herein by reference. These techniques can also be used when attaching the abrasive segments or cutting and control elements of the present invention to pad conditioner support substrate in addition to attaching the abrasive layers of the present invention to the segment blanks. Such techniques allow very precise control of lateral placement of the abrasive segments or abrasive layers, as well as very precise control of relative elevation of the abrasive segments or abrasive layers.

[0072] When an organic bonding material layer is utilized, methods of curing the organic material layer can be a variety of processes known to one skilled in the art that cause a phase transition in the organic material from at least a pliable state to at least a rigid state. Curing can occur, without limitation, by exposing the organic material to energy in the form of heat, electromagnetic radiation, such as ultraviolet, infrared, and microwave radiation, particle bombardment, such as an electron beam, organic catalysts, inorganic catalysts, or any other curing method known to one skilled in the art.

[0073] In one aspect of the present invention, the organic material layer may be a thermoplastic material. Thermoplastic materials can be reversibly hardened and softened by cooling and heating respectively. In another aspect, the organic material layer may be a thermosetting material. Thermosetting materials cannot be reversibly hardened and softened as with the thermoplastic materials. In other words, once curing has occurred, the process can be essentially irreversible, if desired.

[0074] As a more detailed list of what is described above, organic materials that may be useful in embodiments of the present invention include, but are not limited to: amino resins including alkylated urea-formaldehyde resins, melamine-formaldehyde resins, and alkylated benzoguanamine-formaldehyde resins; acrylate resins including vinyl acrylates, acrylated epoxies, acrylated urethanes, acrylated polyesters, acrylated acrylics, acrylated polyethers, vinyl ethers, acrylated oils, acrylated silicones, and associated methacrylates; alkyd resins such as urethane alkyd resins; polyester resins; polyamide resins; polyimide resins; reactive urethane resins; polyurethane resins; phenolic resins such as resole and novolac resins; phenolic/latex resins; epoxy resins such as bisphenol epoxy resins; isocyanate resins; isocyanurate resins; polysiloxane resins including alkylalkoxysilane resins; reactive vinyl resins; resins marketed under the Bakelite™ trade name, including polyethylene resins, polypropylene resins, epoxy resins, phenolic resins, polystyrene resins, phenoxy resins, perylene resins, polysulfone resins, ethylene copolymer resins, acrylonitrile-butadiene-styrene (ABS) resins, acrylic resins, and vinyl resins; acrylic resins; polycarbonate resins; and mixtures and combinations thereof. In one aspect of the present invention, the organic material may be an epoxy resin. In another aspect, the organic material may be a polyimide resin. In yet another aspect, the organic material may be a polyurethane resin.

[0075] Numerous additives may be included in the organic material to facilitate its use. For example, additional crosslinking agents and fillers may be used to improve the cured characteristics of the organic material layer. Additionally, solvents may be utilized to alter the characteristics of the organic material in the uncured state. Also, a reinforcing material may be disposed within at least a portion of the solidified organic material layer. Such reinforcing material may function to increase the strength of the organic material layer, and thus further improve the retention of the individual abrasive segments. In one aspect, the reinforcing material may include ceramics, metals, or combinations thereof. Examples of ceramics include alumina, aluminum carbide, silica, silicon carbide, zirconia, zirconium carbide, and mixtures thereof.

[0076] Additionally, in one aspect a coupling agent or an organometallic compound may be coated onto the surface of each superabrasive material to facilitate the retention of the superabrasive material in the organic material via chemical

bonding. A wide variety of organic and organometallic compounds is known to those of ordinary skill in the art and may be used. Organometallic coupling agents can form chemical bonds between the superabrasive materials and the organic material matrix, thus increasing the retention of the superabrasive materials therein. In this way, the organometallic coupling agent can serve as a bridge to form bonds between the organic material matrix and the surface of the superabrasive material. In one aspect of the present invention, the organometallic coupling agent can be a titanate, zirconate, silane, or mixture thereof. The amount of organometallic coupling agent used can depend upon the coupling agent and on the surface area of the superabrasive material. Oftentimes, 0.05% to 10% by weight of the organic material layer can be sufficient.

[0077] Specific non-limiting examples of silanes suitable for use in the present invention include: 3-glycidoxypropyltrimethoxy silane (available from Dow Corning as Z-6040); γ -methacryloxy propyltrimethoxy silane (available from Union Carbide Chemicals Company as A-174); β -(3,4-epoxycyclohexyl)ethyltrimethoxy silane, γ -aminopropyltriethoxy silane, N-(β -aminoethyl)- γ -aminopropylmethyldimethoxy silane (available from Union Carbide, Shin-etsu Kagaku Kogyo K.K., etc.).

[0078] Specific non-limiting examples of titanate coupling agents include: isopropyltriisostearoyl titanate, di(cumylphenylate)oxyacetate titanate, 4-aminobenzenesulfonyldodecylbenzenesulfonyl titanate, tetraoctylbis(ditridecylphosphite) titanate, isopropyltri(N-ethylamino-ethylamino) titanate (available from Kenrich Petrochemicals, Inc.), neoalkoxy titanates such as LICA-01, LICA-09, LICA-28, LICA-44 and LICA-97 (also available from Kenrich), and the like.

[0079] Specific non-limiting examples of aluminum coupling agents include acetoalkoxy aluminum diisopropylate (available from Ajinomoto K.K.), and the like.

[0080] Specific non-limiting examples of zirconate coupling agents include: neoalkoxy zirconates, LZ-01, LZ-09, LZ-12, LZ-38, LZ-44, LZ-97 (all available from Kenrich Petrochemicals, Inc.), and the like. Other known organometallic coupling agents, e.g., thiolate based compounds, can be used in the present invention and are considered within the scope of the present invention.

[0081] Metal brazing can also be utilized to attach the abrasive layer to a segment blank. Metal brazing techniques are known in the art. For example, in fabricating a diamond particle abrasive segment, the process can include mixing diamond particles (e.g., 40/50 U.S. mesh grit) with a suitable metal support matrix (bond) powder (e.g., cobalt powder of 1.5 micrometer in size). The mixture is then compressed in a mold to form a desired shape. This "green" form of the tool can then be consolidated by sintering at a temperature between 700-1200 degrees C. to form a single body with a plurality of abrasive particles disposed therein. Finally, the consolidated body can be attached (e.g., by brazing) to a segment blank. Many other exemplary uses of this technology are known to those having ordinary skill in the art.

[0082] It should also be noted that various sintering methods can also be utilized to attach the abrasive layer to the segment blank. Suitable sintering methods will be easily appreciated by one of ordinary skill in the art having possession of this disclosure.

[0083] The abrasive layer can also be attached to a segment blank by way of known electroplating and/or electrodeposition processes. As an example of a suitable method for posi-

tioning and retaining abrasive materials prior to and during the electrodeposition process, a mold can be used that includes an insulating material that can effectively prevent the accumulation of electrodeposited material on the molding surface. Abrasive particles can be held on the molding surface of the mold during electrodeposition. As such, the accumulation of electrodeposited material can be prevented from occurring on the particle tips and the working surface of the pad conditioner substrate. Such techniques are described in U.S. patent application Ser. No. 11/292,938, filed Dec. 2, 2005, which is hereby incorporated herein by reference.

[0084] One or more apertures can extend through the insulating material to allow for circulation of an electrolytic fluid from an area outside the mold through the mold and to the surface of the pad conditioner substrate in order to facilitate electrodeposition. Such circulation can be advantageous as it is generally necessary to keep a sufficient concentration of ions in an electrolytic fluid at the location of electrodeposition. Other well known techniques can also be utilized, it being understood that the above-provided example is only one of many suitable techniques.

[0085] The segment blank can similarly be attached to the pad conditioner substrate in a variety of manners. Depending upon the material from which the segment blank is formed, various manners of fixing the segment blank to the pad conditioner substrate may be utilizing. Suitable attachment methods include, without limitation, organic binding, brazing, welding, etc.

[0086] The geometric configuration of a given abrasive segment can vary. For example, in one aspect the abrasive segment can include a generally rectangular or trapezoidal segment blank with a layer of abrasive material attached to an upper portion thereof. The size of the segment blank can vary. In one aspect of the invention, segment blank size can be adjusted to achieve uniform distribution of diamond particles and/or cutting blades about an annular ring array. In the case of particle abrasive segments, each segment can contain a plurality of diamond particles with pitch set from 3x to 10x of the diamond size. Smaller segments can be better distributed to share the loading during dressings.

[0087] The modular nature of the present systems allows a great deal of flexibility in attaching the abrasive layer to the segment blanks. As the segment blanks can be prepared separately from the pad conditioner substrate, a variety of manufacturing advantages can be realized when applying the abrasive layer to the segment blank, without regard to the size, shape, mass, material, etc., of the pad conditioner substrate to which the segment blanks will eventually be attached.

[0088] In one aspect, the abrasive segments arranged about the face of the conditioner substrate can each be substantially the same in size, shape, abrasive composition, height relative to one another, etc. In other embodiments, the size, shape, abrasive composition, height relative to one another, etc., can be purposefully varied, to achieve optimal design flexibility for any particular application. Also, each of the aforementioned qualities can be varied from one segment to another: e.g., alternating segments can include PCD abrasive pieces, chips or slats, with adjacent segments including abrasive particles.

[0089] The retention of abrasive segments or elements on the pad conditioner substrate can be improved by arranging the abrasive segments or elements such that mechanical stress impinging on any individual abrasive segment or element is minimized. By reducing the stress impinging thereon, abra-

sive materials can be more readily retained in place on the substrate, particularly for delicate tasks. Minimizing of stress variations between segments or elements can be accomplished by spacing the segments or elements evenly (or consistently) from one another, leveling to a uniform height (relative to the face of the pad conditioner substrate) an uppermost portion of each segment or element, radially aligning the segments or elements about the face of the pad conditioner substrate, etc. Various other height and spacing techniques can be utilized to obtain a desired affect.

[0090] In one embodiment of the invention, the spacing of the abrasive segments can be adjusted to alter the contact pressure of the contact portion (e.g., the portion of the segment that engages and removes material from the CMP pad) of each segment. In general, the farther the segments are spaced from one another, the higher the contact pressure between the segment and the CMP pad. Thus, a higher density of abrasive segments across the face of the pad conditioner substrate can, in some cases, provide a more desirable abrasive interface between the pad conditioner substrate and the CMP pad. In other applications, a lower density of abrasive segments may be beneficial. In either case, the present invention provides a great deal of design flexibility to obtain the optimal abrading profile.

[0091] By forming the abrasive segments in individual units having defined geometric shapes, arrangement of the abrasive segments in a very precise manner becomes much easier. As the defined geometric shapes can be replicated fairly precisely from one abrasive segment to another, the positioning of, and accordingly, the stress impinged upon, each abrasive segment can be accomplished fairly consistently across the face of the pad conditioner substrate in question. With prior art abrasive grits, for example, the overall shape and size of each a plurality of grits might change considerably from one grit to another, making precise placement of the grits difficult to accomplish. This problem is adequately addressed by the advantageous features of the present invention.

[0092] It has been found that diamond pad conditioners used commercially normally contain about ten thousand diamond particles. Due to the distortion of the substrate, particularly when the disk is manufactured by a high temperature process (e.g. by brazing), and also the distribution of particle sizes and diamond orientations, the cutting tips are located at different heights. When they are pressed against a polishing pad, only about 1% of the protruded diamond can be in engagement with a pad. This can increase the stress on the diamond cutting most deeply into the pad, and the diamond may break and cause catastrophic scratching of the expensive wafers.

[0093] By utilizing the reverse casting methods as described above, the height difference of between particles can be greatly reduced. In one aspect of the invention, abrasive segments or elements are set on a flat metal (e.g. stainless steel) mold with designed spacing in a retainer ring. Epoxy with hardener fully mixed can be poured into the retainer ring to fill up and cover all segments. After curing (with or without heating), the retainer ring and the mold can be removed. The abrasive segments or elements are thereby firmly embedded in the epoxy matrix. Due to the leveling of the abrasives by the flat mold, the tip height variations of the tallest abrasives are minimized.

EXAMPLES

[0094] The following examples present various methods for making the pad conditioners of the present invention. Such examples are illustrative only, and no limitation on the present invention is to be thereby realized.

Example 1

[0095] A pad conditioner is formed by arranging diamond particles (e.g. 50/60 mesh) on a stainless steel flat mold (also, a slightly convex or contoured mold can be utilized) having a layer of adhesive (e.g. acrylic). A hard rubber material is used to press individual diamond particles into the adhesive while tips of the particle are leveled by the flat mold. A mixture of epoxy and hardener is then poured onto the particles protruding outside the adhesive (a containment ring oriented outside the mold can retain the epoxy). After curing, the mold is then removed and the adhesive is peeled away. The resulting dresser contains diamond particles protruding outside a solidified epoxy substrate. The back of the epoxy can be machined and the disk adhered to a stainless steel (e.g. 316) plate with fastening holes for mounting on a CMP machine.

Example 2

[0096] A pad conditioner is formed by radially arranging serrated PCD blades. As in the previous example, the teeth of the PCD blade are leveled with a mold that can be positioned either on the bottom or on the top of the pad conditioner. Epoxy is then cast as in the previous example. In the situation where the mold is on the top, the blades are pressed slightly into the slot of a substrate and the slot is sealed by epoxy or silicone.

Example 3

[0097] A composite design combining the embodiments of Example 1 and Example 2 discussed above. This design leverages the many cutting tips of Example 1 with the cutting efficiency of Example 2. In this Example 3, smaller organic abrasive segments were formed by using a fiber reinforced polymer that is generally harder than epoxy. The organic segments are then radially arranged about a pad conditioner substrate with the blades of Example 2 interspersed therebetween. The cutting tips of the blades are leveled so as to be

about 20 microns higher than were the tips of the organic abrasive segments. In this manner, the penetration depth of blade cutting teeth is controlled, while the organic cutting teeth play a secondary role in dressing the pad with the effect of removing glaze and also grooving the pad.

[0098] It is to be understood that the above-described arrangements are only illustrative of the application of the principles of the present invention. Numerous modifications and alternative arrangements may be devised by those skilled in the art without departing from the spirit and scope of the present invention and any appended or following claims are intended to cover such modifications and arrangements. Thus, while the present invention has been described above with particularity and detail in connection with what is presently deemed to be the most practical and preferred embodiments of the invention, it will be apparent to those of ordinary skill in the art that numerous modifications, including, but not limited to, variations in size, materials, shape, form, function and manner of operation, assembly and use may be made without departing from the principles and concepts set forth herein.

What is claimed is:

- 1. A method for conditioning a CMP pad, comprising:
 - cutting the CMP pad with superabrasive cutting elements; and
 - controlling a degree of contact between the CMP pad and the cutting elements using control elements, wherein the degree of contact is established through placement of the control elements relative to the cutting elements.
- 2. The method of claim 1, wherein controlling the degree of contact includes alternating regions of cutting elements with regions of control elements.
- 3. The method of claim 2, wherein controlling the degree of contact includes locating the regions of control elements at a distance from the regions of cutting elements to establish the degree of contact in relation to material characteristics of the CMP pad.
- 4. The method of claim 2, wherein controlling the degree of contact includes locating the regions of control elements at a distance from the regions of cutting elements to affect a degree of compression of the CMP pad along a leading edge of the regions of cutting elements.

* * * * *