

[72] Inventor **Elmer F. St. Amand**
Hollywood, Calif.
 [21] Appl. No. **767,354**
 [22] Filed **Oct. 14, 1968**
 [45] Patented **June 1, 1971**
 [73] Assignee **American Hospital Supply Corporation**
Evanston, Ill.

[56]		References Cited	
UNITED STATES PATENTS			
2,304,547	12/1942	Cutter	248/359
2,882,388	4/1959	Garland	220/94(A)UX
3,215,299	11/1965	Coanda	215/100
3,369,690	2/1968	Hayes	215/100(A)
3,384,258	5/1968	Singier	215/100(A)
3,387,732	6/1968	Jellies	215/100(A)
3,441,172	4/1969	Dike	215/100(A)X

Primary Examiner—Donald F. Norton
Attorneys—Larry N. Barger and Robert T. Merrick

[54] **HANGER CONSTRUCTION FOR MEDICAL LIQUID CONTAINER**
2 Claims, 4 Drawing Figs.

[52] U.S. Cl. **215/100A, 220/94A**
 [51] Int. Cl. **B65d 23/10**
 [50] Field of Search **215/100, 100 (A), 1.5; 150/5; 248/359, 360; 220/94 A; 222/180**

ABSTRACT: A plastic medical liquid container with a hinged hanger integrally connected to the container at an indented recess in the container's bottom wall. This hanger has an aperture and snaps into an undercut wall section of a lug which is spaced between two legs of the container, thus keeping the hanger tucked into the recess when the plastic container sits on a flat surface. To provide structural strength to the container, the legs are convexly curved and smoothly blend into the indented recess which is in the form of concave arch.

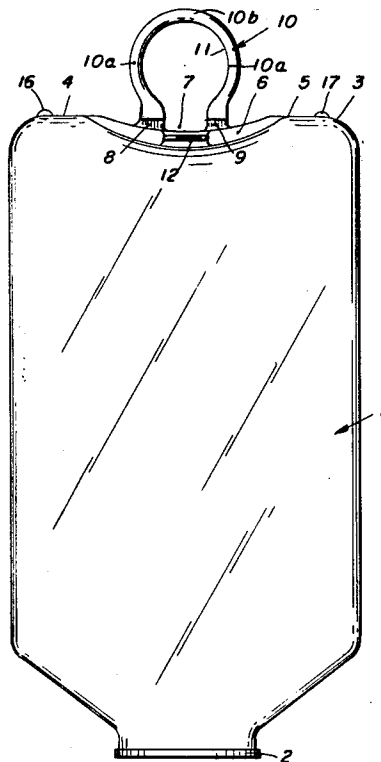

FIG. 1.

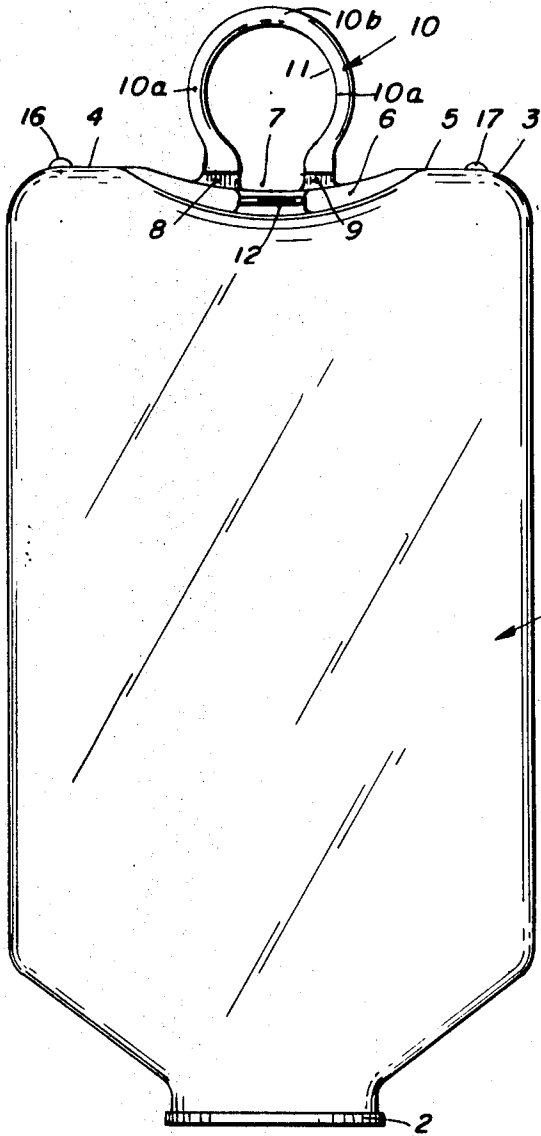

FIG. 2.

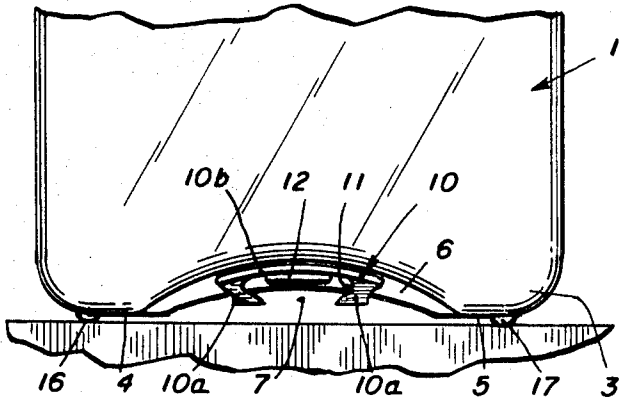

FIG. 3.

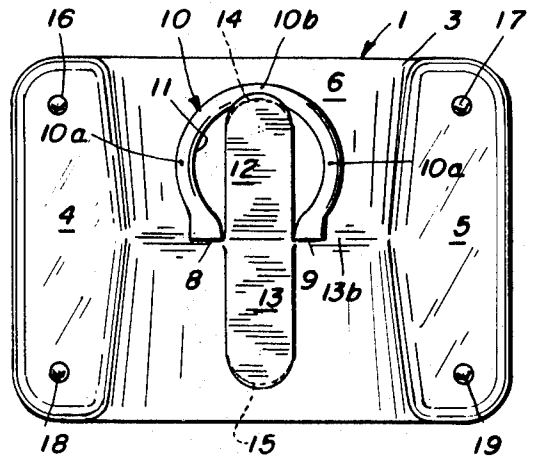
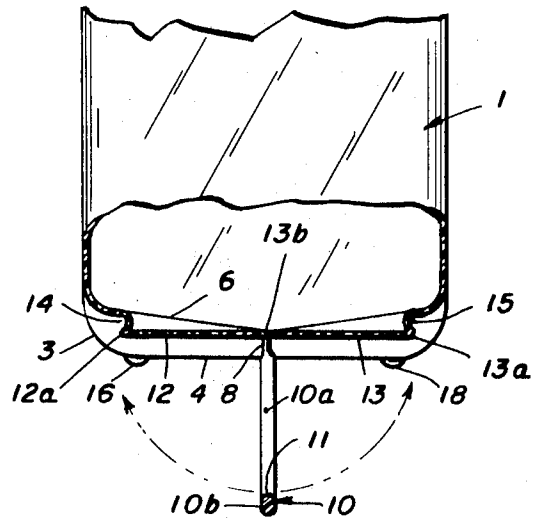

FIG. 4.



INVENTOR
 ELMER F. ST. AMAND
 BY *Larry M. Barger*

ATTORNEY

HANGER CONSTRUCTION FOR MEDICAL LIQUID CONTAINER

This invention relates to a hanger system for a plastic medical liquid container.

Medical liquid containers are used, for example, to store and dispense sterile liquids used in irrigating surgical wounds, and to store and intravenously dispense solutions such as dextrose and saline to patients. These containers have hangers at bottom ends thereof for suspending the containers in a mouth-downward position. It is to these bottom hangers that this invention relates.

In a previous application, Ser. No. 622,520, now issued as U.S. Pat. No. 3,387,732, it was proposed to include an integral suspension tab joined by a flexible web to a recessed bottom area between two protuberant base sections or legs of a plastic container. When the container was standing upright on its base, the suspension tab was tucked into the recess and held there by elongated undercut retention pockets integral with the protuberant base sections.

While the structure disclosed in the above-mentioned application works well to keep the suspension tab retained within the recess, it does have a disadvantage. The undercut walls integral with the protuberant base sections cause a weak area in the container base which could split, particularly if the container were filled with liquid and dropped on a floor.

This problem has been overcome by the present invention which provides a separate lug spaced between the two protuberant base sections. This lug has a short sloping undercut wall section at its outer end for maintaining the suspension tab folded in the recess. The protuberant base sections rather than having integral undercut wall portions now blend smoothly with a recessed concave arch at a center of the container's bottom, thus providing a strong base for the container.

Understanding of the invention will be enhanced with reference to the drawings, in which:

FIG. 1 is a front elevational view of the container suspended mouth downwardly;

FIG. 2 is an enlarged fragmentary front elevational view of a bottom portion of the container;

FIG. 3 is a bottom plan view of the container; and

FIG. 4 is a fragmentary side elevational view of the container's bottom portion, with a section broken away to show the details of the lug.

In these drawings, FIG. 1 shows a plastic container 1 which has a hollow body connected to a mouth 2, which container can be used for administering parenteral solutions to a patient, or for irrigating a surgical wound with liquid. When the container is used to dispense parenteral solutions, an administration set is attached to mouth 2 of the container. However, since the administration set forms no part of this invention, it has not been shown in the drawings.

The important part of the present invention has to do with the hanger structure for suspending the container. As shown, the container 1 has a base 3 which includes a pair of protuberant base sections 4 and 5 which are joined by an indented base wall 6. This base wall 6 in FIG. 2 is spaced above the protuberant base sections to form a recess 7. Thin flexible webs 8 and 9 are integrally joined to the indented base wall in this recess. A U-shaped suspension tab 10 with an aperture 11 has legs or strap portions 10a which are integrally joined to these webs to provide a bendable hanger that can be tucked into recess 7 so as not to interfere with a flat surface on which the container sits. For setting the container on a flat surface, the protuberant base sections can include base pads 16, 17, 18, and 19, if desired.

Positioned between the protuberant base sections 4 and 5 is a pair of lugs 12 and 13, one on each side of a center of the indented base wall. These lugs extend outwardly to undercut wall sections 14 and 15 adjacent outer edges of the base. The undercut wall sections 14 and 15 form acute angles with the base wall, thus creating retention areas into which the suspension tab can be snapped. There are two lugs, so that the suspension tab 10 can be retained at either extreme of its 180° arc. When the container is to be suspended as in FIG. 1, the

nurse or physician simply pulls the tab out from the undercut wall section of the lug, and the container is ready for hanging. The tab may also be released by firmly pushing inwardly on the slightly resilient lug to displace the lug from suspension tab 10. Such release occurs at least in part because the side strap portions or legs 10a of the tab extend along the indented base wall when the tab is in its folded or retracted position. Since the tab is relatively stiff, inward flexure of the base wall in the immediate vicinity of the lug tends to force the lug out of the plane of the retracted tab until the latching action of the tab is overcome by the intrinsic restoring forces of the tensioned tab and by the resistance of legs of that tab to further flexure. Therefore, inward displacement of the lug causes the tab to snap free into a released position.

In the absence of distorting force applied to the base wall in the localized area of the tab, or of an outward prying force applied directly to the tab's free end, the retracted tab is held firmly in its retracted or latched position largely because of the tension of the tab's side and end strap portions 10a and 10b. In other words, when the tab is latched in retracted position (or is forced over the end portions 12a or 13a of the respective lugs into a fully retracted position) a slight distortion of the tab occurs. Since the end portion of each lug is spaced from the hinge line 13b, a distance is a normal direction slightly greater than that of the end strap portion's inner edge, latching of the tab is accompanied by limited elongation of the tab and, specifically, by limited inward flexure of side strap portions or legs 10a. The resistance of such legs to inward flexure results in a tensioning of the tab which effectively hold such tab in its retracted position.

In application Ser. No. 622,520, the hanger structure was held in folded condition by undercut walls which were integral with the protuberant base sections and the undercut walls were quite long, extending substantially across the entire width of the container. Because the undercut walls were long, and also were an integral part of the load-bearing protuberant base sections, some containers developed weakened areas along the protuberant base sections in these undercut regions.

The present invention overcomes this disadvantage because the lugs 12 and 13 for holding the hanger in folded condition are spaced between the protuberant base sections 4 and 5 and have short undercut wall sections 14 and 15 forming the retention areas. Now that the protuberant base sections are not needed to retain the hanger in recess 7, the protuberant base sections 4 and 5 are preferably convexly curved and smoothly blend into the indented base wall 6 which is in the form of a concave arch. I have found that this construction greatly strengthens the base structure and reduces the chance of container rupture if the container is filled with liquid and dropped on a floor. The container of the attached drawings can be blow molded of a plastic material such as polyethylene, polypropylene or copolymers of polyethylene and polypropylene, to give a hanger construction which can be conveniently tucked into a recess in the container and maintained there by a lug.

In the foregoing specification, I have used a specific example to explain my invention. It is understood that persons skilled in the art can make certain modifications to this example without departing from the spirit and scope of this invention.

I claim:

1. A suspendable, medical liquid container comprising:

a molded, one-piece plastic body including a bottom for engaging a support surface and by which said container is suspended,

said bottom including spaced protuberant base sections, extending transversely along opposed peripheral sides of said bottom, and having a horizontal plane across bottom surfaces of these protuberant base sections, said protuberant base sections having inner margins which merge together smoothly on a gentle arc providing an arcuate outer surface defining a concave indentation in the body's bottom wall; a flexible web

3

joined to the body along a medial line between the base sections; a tab connected to the web and having an opening therethrough and an end latch section immediately outwardly of this opening; said arcuate outer surface extending across the tab's width so the tab can take on a slight concave curve when held in the indentation by the latch section and generally follow the arcuate contour of the indentation for compact containment of the tab in the indentation; at least one latch-lug disposed between the protuberant base sections and projecting smoothly from the medial hinge

4

line with generally triangular sidewalls and a bottom wall of the lug being integral with an outer undercut lip disposed slightly above the hinge line for releasably holding the latch section of the tab above the horizontal plane across the protuberant base sections.

2. The structure as claimed in claim 1 in which a second latch-lug duplicating the first extends diametrically from said hinge line whereby said tab can releasably be secured in said indentation at both limits of its pivotal movement and above the hinged connection of the tab.

5

10

15

20

25

30

35

40

45

50

55

60

65

70

75