

Dec. 24, 1957

C. L. FENDER

2,817,261

PICK-UP AND CIRCUIT FOR STRINGED MUSICAL INSTRUMENT

Filed March 29, 1956

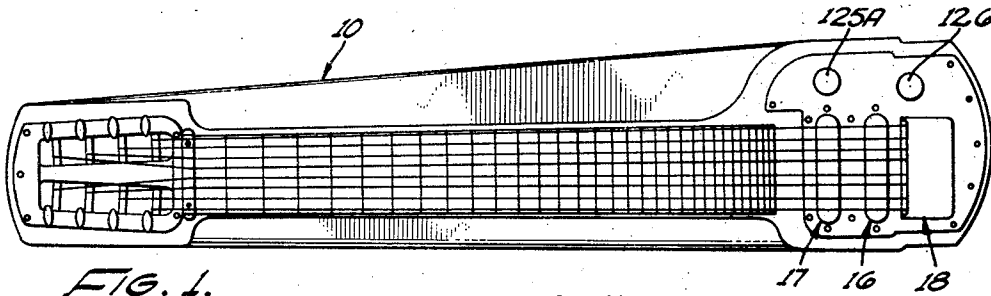

FIG. 1.

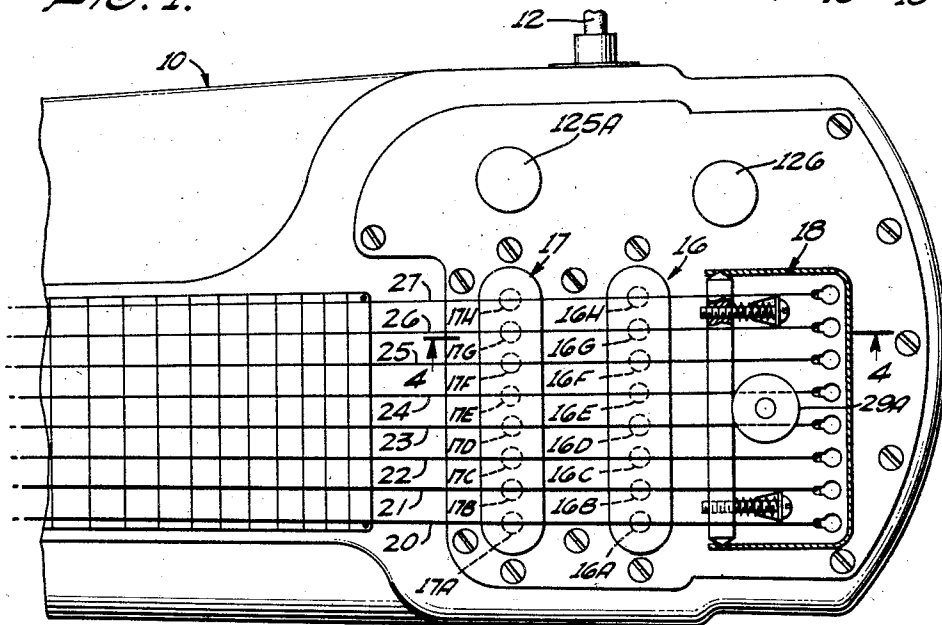

FIG. 2.

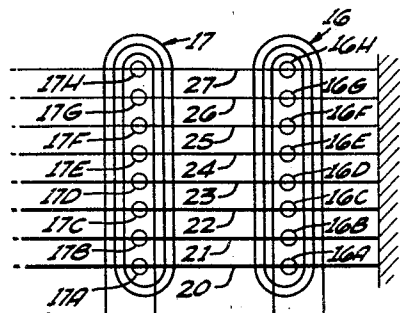

FIG. 3.

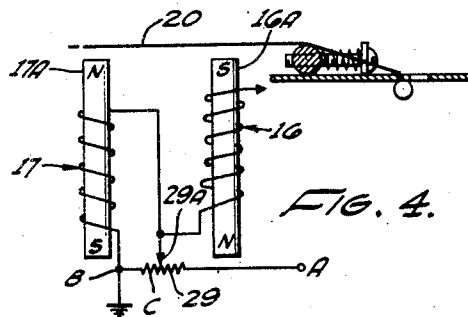

FIG. 4.

CLARENCE L. FENDER
INVENTOR.

BY *Lyons & Lyons*

ATTORNEYS

1

2,817,261

**PICK-UP AND CIRCUIT FOR STRINGED
MUSICAL INSTRUMENT**

Clarence L. Fender, Fullerton, Calif.

Application March 29, 1956, Serial No. 574,732

5 Claims. (Cl. 84—1.16)

The present invention relates to means for achieving the following results on electric guitars: (1) means for varying the balance between the fundamental content and the harmonic content of the signal developed by the strings; (2) cancellation of hum caused by extraneous magnetic fields; and (3) increased signal amplitude.

In general, the present arrangement involves two coils which are positioned so that one reproduces the fundamental frequency of a vibrating string or strings more than the other, while the other coil reproduces the harmonic content of the same string or strings more than such one coil. These two coils are interconnected in a novel manner in the input circuit of a vacuum tube amplifier, and with different magnetic polarities as is described in detail hereinafter.

For purposes of definition, the aforementioned coil which is more reproductive or responsive to the fundamental frequency is termed the rhythm coil, whereas the other coil referred to as being more reproductive or responsive to the harmonic content is termed the lead coil. An adjustable resistance is interconnected with such lead and rhythm coils and has a manually adjustable tap, movement of which serves to shunt out the rhythm coil in varying degrees, or to allow all of the signals from such rhythm coil to have effect on the input circuit of the amplifier. In this respect, the present arrangement is somewhat similar to the tone control described in my co-pending application, Serial No. 371,626, filed July 31, 1953, now Patent No. 2,784,631, granted March 12, 1957. However, the present arrangement is characterized by the fact that the rhythm and lead coils are connected in series and are wound in opposite directions, i. e., one coil is wound clockwise and the other coil is wound counterclockwise, and the magnetic polarity of the lead coil is opposite to the magnetic polarity of the rhythm coil. Another important feature is that these general purposes are accomplished with reduction or cancellation of noise which might otherwise be produced by extraneous magnetic fields from neighboring devices, power lines, etc.

Using these techniques, a single control, i. e., an adjustable potentiometer resistor, serves to shunt out the so-called rhythm coil in varying degrees while the output of the lead coil remains substantially constant, thereby varying the balance between the fundamental content and the harmonic content of the signal.

Greater signal amplitude is realized because of the two coils and their relatively close spacing. This close spacing allows the steel string to both attract and conduct the magnetic flux between the two coils because of opposite magnetic polarity, resulting in a total signal amplitude greater than that produced by a single coil or two coils not so closely spaced.

It is, therefore, generally an object of the present invention to provide a control arrangement having the features and advantages indicated above.

Another specific object of the present invention is to provide an improved control arrangement of this character which is relatively simple and inexpensive.

2

Another specific object of the present invention is to provide an arrangement of this character which is relatively insensitive to extraneous magnetic fields that otherwise may introduce noise into the system.

5 The features of the present invention which are believed to be novel are set forth with particularity in the appended claims. This invention itself, both as to its organization and manner of operation, together with further objects and advantages thereof, may be best understood by reference to the following description taken in connection with the accompanying drawings, in which:

Figure 1 illustrates a top plan view of a guitar embodying features of the present invention;

10 Figure 2 is a top plan view, on an enlarged scale, of a portion of the guitar shown in Figure 1;

Figure 3 represents, partly in schematic and partly in structural form, control circuitry which is incorporated in the guitar illustrated in Figure 1 and embodies important features of the present invention; and

20 Figure 4 illustrates, in greater detail, the magnetic polarity of the lead and rhythm coils in the guitar described in the previous arrangements.

The guitar 10 has the control circuitry illustrated in Figure 3 contained therein and the output of such control circuitry is conveyed over the cable 12 (Figure 2) to the input circuit of a remotely located amplifier which is indicated generally by the dotted rectangle 14 in Figure 3.

The guitar is provided with a lead coil 16, as defined above, as well as a rhythm coil 17, also as defined above.

30 It is noted that the lead coil 16 is relatively close to the structure 18 which supports one end of each of the eight guitar strings 20, 21, 22, 23, 24, 25, 26 and 27, whereas the rhythm coil 17 is located relatively remote from the supporting structure 18 to thereby respond more to the fundamental frequency or vibration of such strings.

35 The lead coil 16 comprises a plurality of turns of wire, the length of the coil being somewhat longer than the distance between the outermost strings 20 and 27, and the axis of such coil extends generally perpendicularly with respect to the axis of any one particular string. The coil 16 is wound around eight pole pieces 16A, 16B, 16C, 16D, 16E, 16F, 16G and 16H which are disposed underneath corresponding strings 20, 21, 22, 23, 24, 25, 26 and 27, but spaced therefrom and in inductive relationship to the same.

40 Similarly, the rhythm coil 17 comprises a plurality of turns of wire, the axis of the rhythm coil 17 extending substantially perpendicular to the strings, and the length of the coil 17 is somewhat longer than the distance between the outermost strings 20 and 27. The coil 17 is wound around the eight pole pieces 17A, 17B, 17C, 17D, 17E, 17F, 17G and 17H which are disposed underneath corresponding strings 20, 21, 22, 23, 24, 25, 26 and 27, but spaced therefrom in inductive relationship.

45 The strings 20, 21, 22, 23, 24, 25, 26 and 27 are, of course, of magnetizable material, and movement of such strings, as in the strumming of the guitar or playing of the guitar, results in voltages induced in the coils 16 and 17. These voltages are transferred to the input circuit of the amplifier circuit 14 using the circuitry which is now described.

50 The coils 16 and 17 are serially connected with one terminal of the coil 17 grounded and one terminal of the coil 16 being returned to ground through the volume control resistance potentiometer 125 which has its movable tap 125A coupled to an input terminal of a conventional amplifier stage 14. The junction point of coils 16 and 17 is connected to the adjustable tap 29A on resistance 29, one terminal of which is grounded. The resistance 29 may have a magnitude of one-fourth of one megohm. The volume control resistance 125 may have a magnitude of one megohm. An adjustable control re-

sistance 126 has one of its terminals connected to the ungrounded terminal of volume control resistance 125 and has the other one of its terminals connected to a terminal of condenser 127, the other terminal of condenser 127 being grounded. The value of resistance 126 may be one megohm while the condenser may have a value of .05 microfarad. It is understood that these values are illustrative and, of course, practice of the invention is not limited to these specific values, since it is understood that these values may be within a range of values and yet produce the operation and results which are now described.

It is noted with reference to Figure 4 that the pole pieces 16A and 17A are bar permanent magnets having their north (N) and south (S) poles oriented as shown and that the coils 16 and 17 are wound in opposite fashion around their corresponding pole pieces for noise reduction or cancellation. It is noted that the bar magnets comprising pole pieces 16A-16H are each oriented so that their south pole extends upwardly; and the bar magnets comprising pole pieces 17A-17H are each oriented so that their north poles extend upwardly. Alternatively, the bar magnets 16A-16H may have their north poles extending upwardly with the south poles of the bar magnets 17A-17H extending upwardly.

It is noted that the spring 20, of magnetizable material, constitutes a portion of the flux path for that flux produced by the magnet bars 16A and 17A, and that the flux produced by the bar magnet 16A is in additive relationship to the flux produced by bar magnet 17A since the north and south poles of each are adjacent. The signals introduced into the two coils as a result of vibration of the string 20 are in additive relationship because of the direction of current flow which is governed by the magnetic polarity and direction of winding of the two coils. However, considering the condition of the presence of a magnetic field from a neighboring electrical device, power line or the like, such field may be considered to introduce a voltage of the same amplitude in each coil 16 and 17, but however of opposite phase since the coils are wound and connected in bucking relationship. This means that any noises from such source, which is otherwise manifested as an objectionable hum, is effectively reduced or cancelled. It is for this reason that the arrangement may be characterized as a hum bucking arrangement.

The operation of the circuitry is now described in relationship to the tap 29A on the shunt control resistance 29. The two extreme positions of tap 29A are denoted by the letters A and B and an intermediate position of tap 29A is represented by the letter C. When the tap 29A is at position B, the rhythm coil 17 is short-circuited so that any voltage induced in the coil 17 has no effect on the signal delivered to the amplifier. Thus, in position B, the rhythm coil 17 is short-circuited and the lead coil 16 furnishes all of the signal, i. e., a tone is produced which is more responsive to the harmonic content of the vibrating strings.

In the other extreme, position A, the two coils 16 and 17 are, of course, serially connected and both furnish signal. Thus, in position A a tone is produced which is responsive both to the fundamental as well as to the harmonic content of the vibrating strings, and these volt-

ages, i. e. signal voltages, are essentially in additive relationship. Movement of the tap 29A from position B to position A thus provides different shunting effects on the rhythm coil 17 so that different amounts of current produced in coil 17 flow through the coil 16.

The shunting effect of resistance 29 on coil 17 has some effect on the degree to which hum bucking is accomplished. When tap 29A is at position A the hum caused by extraneous magnetic fields is greatly reduced because of the hum bucking relationship of the two coils. When tap 29A is at position B, the amount of hum is that due essentially to the pickup in only one coil, namely, coil 16, instead of additive pickup in two coils, as is present in prior art arrangements.

While the particular embodiments of the present invention have been shown and described, it will be obvious to those skilled in the art that changes and modifications may be made without departing from this invention in its broader aspects and, therefore, the aim in the appended claims is to cover all such changes and modifications as fall within the true spirit and scope of this invention.

I claim:

1. In a musical instrument, a musical string, a first assembly comprising a first coil and a first permanent magnet in magnetic relationship to said string, a second assembly comprising a second coil and a second permanent magnet spaced from said first assembly and in magnetic relationship to said string, said first magnet having its south pole adjacent to said string and its north pole relatively remote from said string, said second magnet having its north pole adjacent to said string and its south pole relatively remote from said string, said first and second coils being serially connected and having opposite polarities with respect to voltages induced therein from an extraneous source so that such voltages are subtracted.

2. An instrument as set forth in claim 1 including an adjustable resistance shunting one of said coils.

3. An arrangement as set forth in claim 1 in which said first coil comprises a lead coil and said second coil comprises a rhythm coil, and an adjustable resistance shunts the rhythm coil.

4. An instrument as set forth in claim 1 including a volume control potentiometer resistance which is serially connected with said first and second coils, and an adjustable resistance shunting one of said coils.

5. An instrument as set forth in claim 1 including a volume control potentiometer resistance serially connected with said first and second coils, an adjustable resistance shunting one of said coils, a third adjustable resistance, a condenser, said third resistance and said condenser being serially connected and shunting said volume control resistance.

References Cited in the file of this patent

UNITED STATES PATENTS

2,027,073	Vierling	Jan. 7, 1936
2,179,237	Stibitz	Nov. 7, 1939
2,262,335	Russell	Nov. 11, 1942
2,413,062	Miessner	Dec. 24, 1946