

L. J. Smith,

Railway Chair:

No. 108402.

Patented Oct. 18. 1870.

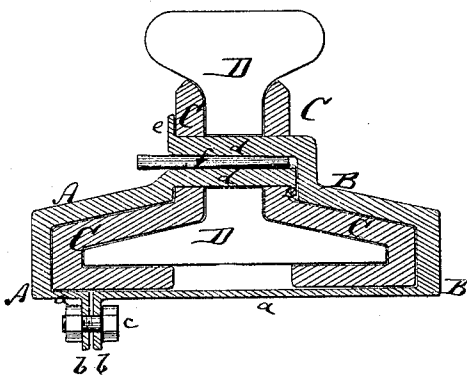

Witnesses.

*A Remmeisenhof
Alex. F. Roberts*

Inventor.

L. J. Smith

per

Wm. L.

Attorneys.

United States Patent Office.

LOYST J. SMITH, OF NEW YORK, N. Y., ASSIGNOR TO HIMSELF AND HENRY D. BLAKE, OF SAME PLACE.

Letters Patent No. 108,402, dated October 18, 1870.

IMPROVEMENT IN RAILWAY-CHAIRS AND CLAMPS.

The Schedule referred to in these Letters Patent and making part of the same.

To all whom it may concern:

Be it known that I, LOYST J. SMITH, of the city of New York, in the county and State of New York, have invented a new and improved Railroad-Chair and Clamp; and I do hereby declare that the following is a full, clear, and exact description thereof, which will enable others skilled in the art to make and use the same, reference being had to the accompanying drawing forming part of this specification.

My invention relates to railroad-chairs, and my object is to introduce to the public an improved clamp therefor, which will be first described, and then clearly specified in the claim.

The drawing represents a transverse section of my improvement.

A B are the clamp-plates.

C, the chair.

D, the rail.

a a are arms, flanged at *b*, and fastened by bolt *c* under the chair.

d d are pins on the clamp-plates, having lips *e* reversed in direction to shoulder against the chair.

f is a wedge, which is interposed between the pins *d*, to hold the lips in their proper position against the chair.

Having thus described all that is necessary to a full understanding of my invention,

What I esteem as new, and desire to protect by Letters Patent, is—

The combination, with wedge *f* and chair C, of the plates A B, having arms *a*, flanges *b*, pins *d*, and lips *e*, constructed and relatively arranged as shown in drawing, and for the purpose described.

Witnesses:

GEO. W. MABEE,

T. B. MOSHER.

LOYST J. SMITH.