

No. 674,021.

Patented May 14, 1901.

H. SEE.
ASH EJECTOR.

(Application filed Jan. 25, 1901.)

(No Model.)

3 Sheets—Sheet 1.

Fig. 1.

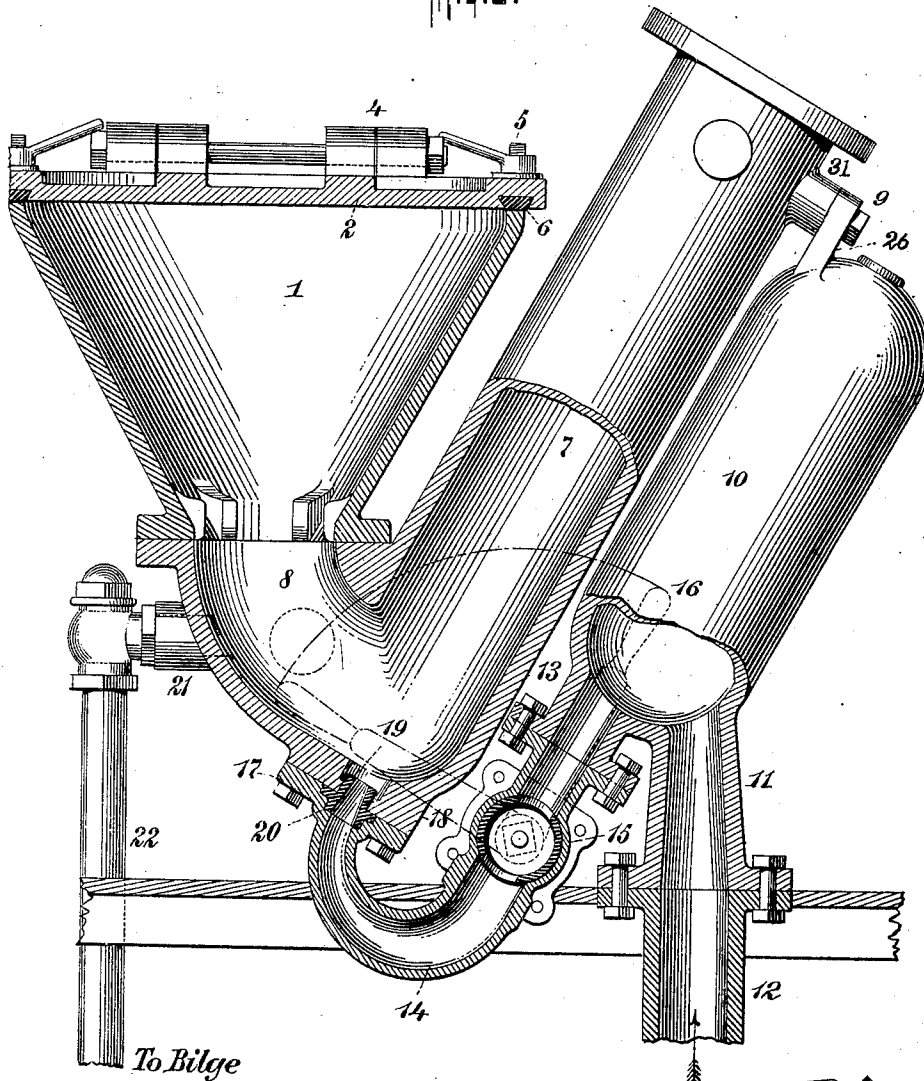

To Bilge

Fig. 5.

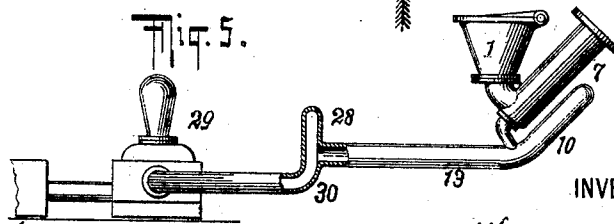

WITNESSES:

Gustave Dietrich
John Kehlentosh

INVENTOR

Horace See
BY
Leah Benjamin
ATTORNEY

No. 674,021.

Patented May 14, 1901.

H. SEE.
ASH EJECTOR.

(Application filed Jan. 25, 1901.)

(No Model.)

3 Sheets—Sheet 2.

Fig. 2.

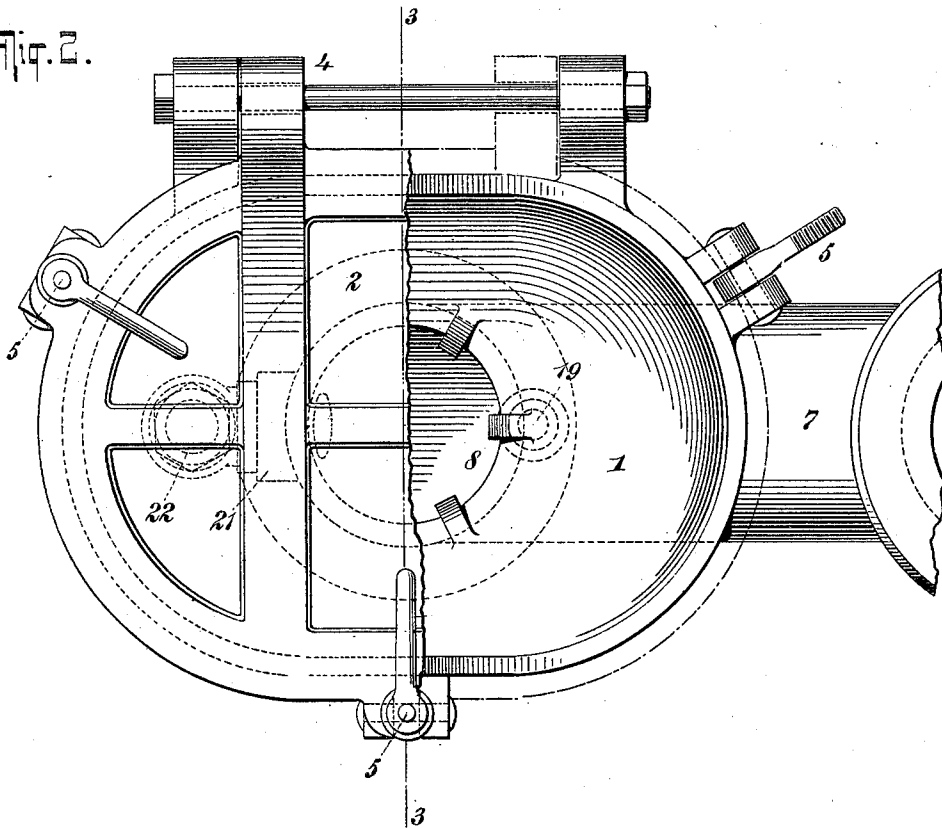
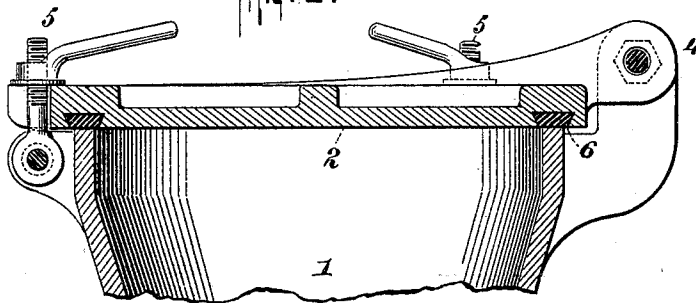

Fig. 3.



WITNESSES:

Gustav Dietrich
John Fehlbeck

INVENTOR

Horace See

BY *Paul Benjamin*
his ATTORNEY

No. 674,021.

Patented May 14, 1901.

H. SEE.
ASH EJECTOR.

(Application filed Jan. 25, 1901.)

(No Model.)

3 Sheets—Sheet 3.

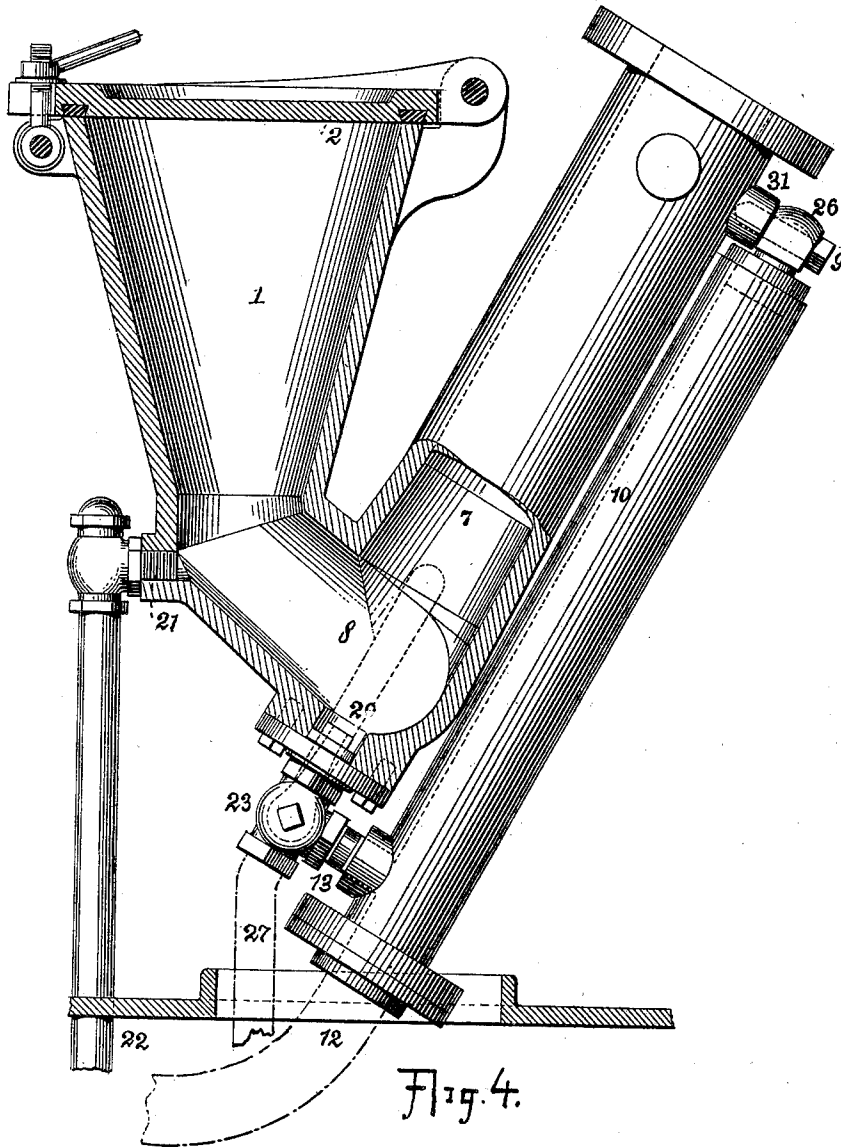

Fig. 4.

WITNESSES:

Gustave Kietzsch
John Schlebeck

INVENTOR

Horace See
BY *Sam Benjamin*
his ATTORNEY

UNITED STATES PATENT OFFICE.

HORACE SEE, OF NEW YORK, N. Y.

ASH-EJECTOR.

SPECIFICATION forming part of Letters Patent No. 674,021, dated May 14, 1901.

Application filed January 25, 1901. Serial No. 44,707. (No model.)

To all whom it may concern:

Be it known that I, HORACE SEE, of the city, county, and State of New York, have invented a new and useful Improvement in Ash-Ejectors, of which the following is a specification.

My invention relates to ash-ejectors of the type set forth in Letters Patent No. 482,759, granted to me September 20, 1892, and in other Letters Patent granted to me at various dates.

My invention consists in the construction and arrangement of the means for automatically maintaining a constant stream of mixed ashes and water from the discharge-pipe; also, in the means whereby the ash-ejector may be conveniently converted into a bilge-pump, and also in the various instrumentalities more particularly pointed out in the claims.

In the accompanying drawings, Figure 1 is a side elevation in partial vertical section. Fig. 2 is a plan view with the top of the cover broken away. Fig. 3 is a transverse section of the upper part of the hopper, with its cover, on the line 3 3 of Fig. 2. Fig. 4 is a modification in which the air-chamber is supported wholly on the discharge-pipe. Fig. 5 shows a second air-chamber introduced into the water-supply pipe between pump and jet.

Similar numbers of reference indicate like parts.

1 is a receptacle, preferably shaped as an inverted hollow cone and forming a hopper into which the ashes to be removed are thrown. 2 is the cover of said hopper, secured thereon by hinges 4 and fastened down by the swinging screw-bolts 5, so that a water-tight joint is formed between cover and hopper when said cover is closed. On the under side of said cover may be a rubber packing-gasket 6, which bears against the upper edge of the hopper.

7 is the main discharge-pipe communicating with the bottom of the hopper. Secured to the side of the discharge-pipe 7 is an air-chamber 10, which extends, preferably, parallel to said discharge-pipe, and therefore at substantially the same inclination. Said chamber is supported by a projection 26 at its upper portion, through which passes a bolt 9, which is received in a lug 31 on discharge-pipe 7. It may also be supported by the hol-

low standard 11, cast integral with it and bolted to the water-inlet pipe 12, as shown. Projecting from the lower end of the air-chamber 10 is a water-delivery pipe 13, having the curved portion 14. In said pipe is arranged the plug-valve 15, which is operated by the handle 16. (Shown in dotted lines.) When said handle is turned in a direction longitudinally the air-chamber 10, the valve is opened, as shown in Fig. 1. When it is turned at right angles to that position, the valve is closed. The extremity of the delivery-pipe 13 is flanged at 17, and this flanged portion is bolted to an offset 18 at the lower portion of the elbow 8. Through this offset 18 an opening 19 is made, which lies in the axial line of the main discharge-pipe 7. In this opening is placed the nozzle 20, which is flanged, as shown, and received in a seat in the flange 17. Communicating with the elbow 8 and between the hopper and the nozzle 20 is a pipe 21, which communicates by the pipe 22 with the bilge of the vessel in which the ash-ejector is placed.

The operation of the above-described apparatus is as follows: Water being pumped in at the pipe 12 passes through the hollow standard 11 and enters the air-chamber 10, thus compressing the air in front of it and forming an elastic expansible cushion for said air in the upper portion of said chamber always acting upon the water therein. The water-current then proceeds through the pipe 13, past the valve 15 when opened, and out at the nozzle 20. An upward jet of water is thus produced in the discharge-pipe 7. The ashes to be ejected are thrown in any suitable way into the hopper 1 and descend through the elbow 8 until they meet the jet projected from the nozzle 20, by the force of which they are carried up, together with the water from the jet, through the discharge-pipe 7 and so ejected through the side of the ship and overboard. The object of the pipes 21 22 communicating with the elbow 8 is to admit air above the ashes in order to break any possible vacuum which would be formed by the action of the jet after the cover of the hopper is tightly closed. The object of connecting this pipe to the bilge of the vessel is to enable the device to serve as a bilge-pump, any water existing in the bilge being (by reason of the pro-

duced vacuum in the hopper and pipes after the hopper-lid is closed) drawn up into the ejector and so carried out of the ship.

In Letters Patent No. 482,759, granted to me September 20, 1892, I have described and shown an ash-ejector of the present type in which a bilge-discharge pass-over pipe is shown extending from the main water-pipe to the conduit immediately below the hopper. That device, however, by the manipulation of suitable valves caused the bilge-water to be drawn up through the water-supply pipe.

In my present application it will be noticed that the bilge-pipe 22 is not connected anywhere with the water-pipe 12, but always opens directly into the bilge of the vessel. All that is required is to close the lid of the hopper, when (the jet being started) the apparatus acts at once as a bilge-pump and continues so to act until there is no more water in the bilge to remove.

I desire to call special attention now to the construction and arrangement of the air-chamber 10 and to the results which it produces, since the latter in a device of this type are of great importance. The action of the pump supplying the water-jet by which the ashes are elevated into the discharge-pipe 7 is, of course, intermittent, the force rising and falling at every stroke. When an accumulation of ashes happens to come over the nozzle at the instant when the force is weakest, a clogging effect results, and the ejector as a whole ceases to deliver its ashes until sufficient pressure has accumulated in the pipe leading from the pump to the jet. This clogging action of the ashes becomes more effective when the pump is located, as it often is on board ship, at a considerable distance from the jet-nozzle, because then the friction of the water in that connecting-pipe tends to diminish the force of the stream. Consequently a longer period of delay elapses after the clogging begins before the water-pressure accumulates sufficiently in that pipe to deliver the ashes. Finally, when the clogging is overcome the obstruction is thrown out with some violence, so that there is a resulting needless wear on the parts of the apparatus.

In Patent No. 483,770, granted to me October 4, 1892, I have shown and described in an ash-ejector of this general type an air-chamber arranged in the pipe leading from the pump, which, as I have stated in the specification of said Letters Patent, assists that pipe in performing its office while the pump is in operation. That air vessel, however, is shown in Fig. 1 of the drawings of my said Letters Patent as standing directly at right angles to the pipe to which it is applied. While an air vessel thus constructed is operative to perform a useful function, I have found that in practice it does not wholly overcome the clogging above described, and I have also found that this is due to the manner in which I have placed that air vessel, simply at right angles to the pipe. On the

other hand, I have discovered that by placing the air vessel as shown, so that the incoming water-current is directed first into the air vessel, so as to act by its momentum strongly to compress the air therein, the clogging difficulty is overcome, because there is thus produced an elastic body of strongly-compressed air, which not only equalizes the flow of water delivered by the pump, but which also when that flow is impeded by the clogging of the ashes at the nozzle instantly exerts its powerful pressure to maintain the force of the jet, and so to break up the clogged mass. The consequence is that instead of the ejector throwing out its stream of mingled ashes and water intermittently and at times with greater violence than at others it ejects a constant steady stream of ashes and water. The result is uniformity of operation, reduction of wear, and saving of time in doing the work.

In the construction of my apparatus illustrated in Fig. 4 the air-chamber 10 is axially in line with the water-supply pipe 12, so that the whole force of the incoming stream is directly exerted in the line of its motion to compress the air. The outflow-pipe 13 is at right angles to the axis of the air-chamber and connects with the chamber of the three-way plug-valve 23, which here replaces the plug-valve 15 of Fig. 1. The air-chamber 10 is supported on the pipe 7 by the bolt 9, which passes through the projection 26, formed on the upper end of the air-chamber instead of at one side thereof, as represented in Fig. 1. The lower end of the air-chamber is carried by the connecting-pipe 13. The three-way plug-valve 15 when suitably turned allows the water-supply to be cut off from the nozzle 20 while establishing communication from nozzle to the drain-pipe 27. In this way any water left in the apparatus after use can be conveniently drained off.

In Fig. 5 I show an air vessel 28 interposed in the water-pipe between the supply-pump 29 and the ejecting apparatus. The delivery-pipe 30 from the pump is curved so that the current is forced into the air vessel 28 in the direction of its longitudinal axis, thus compressing the air in its upper portion. The pipe 13, leading to the air-chamber 10, connects at right angles to said air-chamber, as shown.

I claim—

1. In combination with a vessel and with an ash-ejector of the type wherein ashes are ejected overboard by means of a water-jet traversing a discharge-conduit, a separate branch conduit communicating directly with the bilge of said vessel and with said discharge-conduit between the points of inlet to said discharge-conduit of the ashes and the water-jet, substantially as described.

2. In combination with a vessel, a discharge-conduit leading overboard, means for producing a water-jet directed outwardly through said conduit a branch supply-conduit connecting said discharge-conduit with a recep-

tacle for ashes and a separate conduit connecting said discharge-conduit with the bilge of said vessel, substantially as described.

3. The combination with a vessel of a hopper, means of hermetically closing the same, a discharge-pipe leading overboard, an elbow between said discharge-pipe and said hopper, means for establishing a water-jet through said discharge-pipe, and a branch conduit connected to said elbow at a point between said hopper and said water-jet inlet and communicating with the bilge of said vessel, substantially as described.

4. The combination in an ash-ejector of the type herein set forth of an air-chamber and water inlet and discharge pipes communicating therewith, the said water-inlet pipe being placed at one end of said air-chamber to direct the entering stream of water toward the opposite and closed end of said chamber, substantially as described.

5. The combination in an ash-ejector of the type herein set forth of an air-chamber and water inlet and discharge pipes communicating therewith; the said water-inlet pipe being placed at an acute angle to the longitudinal axis of said air-chamber, substantially as described.

6. The combination in an ash-ejector of the type herein set forth of an air-chamber and water inlet and discharge pipes communicating therewith, the said water-inlet pipe being placed at one end of said air-chamber to direct the entering stream of water toward the opposite closed end of said chamber, and the said water-discharge pipe being placed in the direction of the longitudinal axis of said chamber, substantially as described.

7. The combination in an ash-ejector of the type herein set forth of an elongated air-chamber having water inlet and discharge pipes communicating with said chamber at

or near one end thereof and disposed at an acute angle to one another, substantially as described.

8. The combination in an ash-ejector of the type herein set forth of an inclined ashes-discharge pipe, an elongated air-chamber disposed parallel thereto, a pipe extending from the lower portion of said air-chamber to said discharge-pipe, and a water-supply pipe entering said lower portion of said air-chamber, substantially as described.

9. The combination in an ash-ejector of the type herein set forth of the hopper 1, having cover 2, the inclined ashes-discharge pipe 7 communicating with said hopper, the inclined air-chamber 10, the water-inlet pipe 11 communicating with said air-chamber, and the water-discharge pipe 14 arranged to deliver a water-jet into pipe 7, substantially as described.

10. The combination in an ash-ejector of the type herein set forth of a vertically-inclined ashes-discharge pipe, an air-chamber supported upon said discharge-pipe, a water-inlet pipe to said chamber, and a water-discharge pipe leading from said chamber to said ashes-discharge pipe, substantially as described.

11. The combination with an ejector of the type herein set forth, of an air-chamber located near to said ejector, and a second air-chamber interposed in the water-supply pipe, and between said first air-chamber and the source of water-supply, the water-inlet pipe of each of said chambers being placed at one end thereof to direct the entering stream of water toward the opposite and closed end of said chamber, substantially as described.

HORACE SEE.

Witnesses:

J. R. SERVEISCE,
WILLIAM MOLLOY.