

Aug. 24, 1965

R. BÄR

3,202,399

MULTIPLE-STAGE STEAM TURBINE

Filed Jan. 24, 1963

FIG. 1

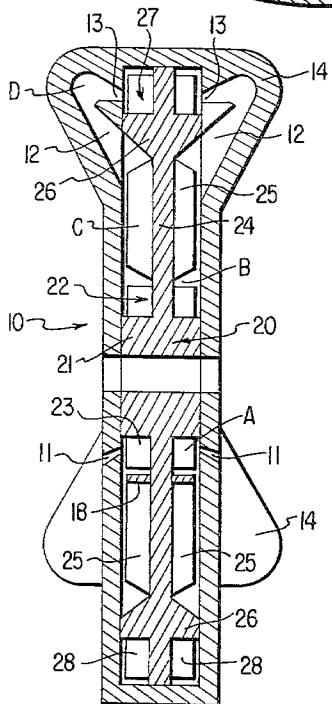
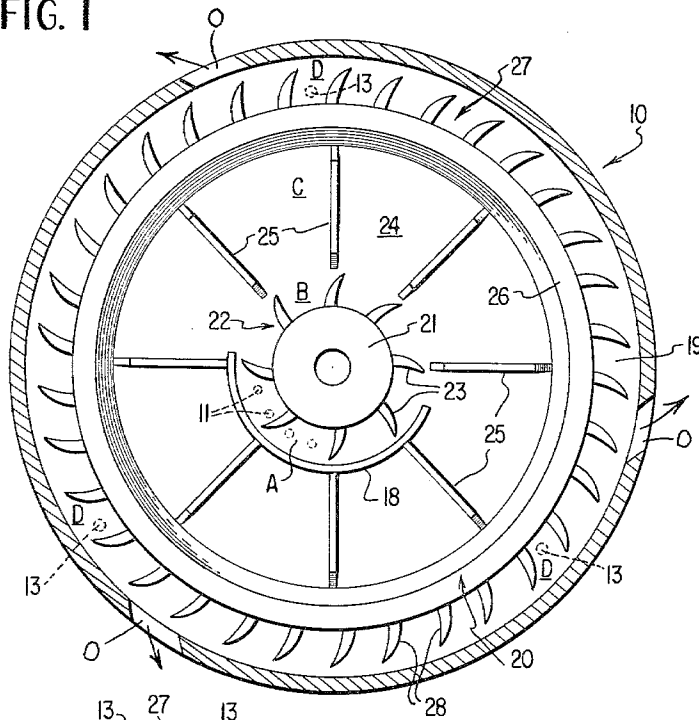

FIG. 2

INVENTOR.
RUDOLF BAER

BY *Dicke and Craig*
ATTORNEYS.

1

3,202,399

MULTIPLE-STAGE STEAM TURBINE

Rudolf Bär, 22 Stockheimer Strasse, Stuttgart-Zuffenhausen, Germany

Filed Jan. 24, 1963, Ser. No. 265,571

Claims priority, application Germany, Mar. 20, 1962, B 65,626; Mar. 22, 1962, B 66,475

6 Claims. (Cl. 253—86)

The present invention relates to a multiple-stage steam turbine, and more particularly to a regenerative type of multiple-stage steam turbine in which a regenerating compressor is interposed between the two turbine stages.

The characteristic feature of the present invention resides in that the steam, which has been put to work in the first turbine stage, is utilized once more in the second turbine stage formed by an additional blade rim after regenerating the steam. The regeneration of the steam is accomplished by allowing the live steam to enter into the inner blade rim and by such a construction of the housing for the first turbine stage that the steam, upon entry into the first turbine stage, remains closed only for such length of time as is necessary for utilizing the steam. The remaining radially outer portion of the housing of the first turbine stage remains open so that the steam is driven into the blade area of the centrifugal force utilization. The steam is put under pressure by the centrifugal force resulting from the movement of the rotor so that its energy is regenerated. The regenerated steam then enters the steam dome accommodating the second turbine stage whence it is utilized for work on the additional blade rim of the second stage of the steam turbine.

Accordingly, it is an object of the present invention to provide a regenerative steam turbine of the type described above which is simple in construction, relatively inexpensive to manufacture, yet offers a high output with economic operation.

It is another object of the present invention to provide a regenerative multi-stage steam turbine which is so constructed and arranged as to permit substantial saving in fuel.

Still a further object of the present invention resides in the provision of a steam turbine in which the steam, after passage through the first turbine stage is regenerated in a particularly appropriate manner prior to admission to the second turbine stage.

These and other objects, features, and advantages of the present invention will become more obvious from the following description when taken in connection with the accompanying drawing which shows, for purposes of illustration only, one embodiment in accordance with the present invention, and wherein

FIGURE 1 is a transverse cross sectional view through a steam turbine in accordance with the present invention, and

FIGURE 2 is an axial longitudinal cross sectional view through the steam turbine of FIGURE 1.

Referring now to the drawing wherein like reference numerals are used throughout the various views to designate like parts, the live steam used in the first turbine stage of the multiple-stage steam turbine of the present invention is regenerated in its energy by a compressor provided with radial blades which is arranged at and rotates in unison with the turbine rotor. The turbine rotor itself is a unitary structure to be referred to hereinafter as "circular column." The term "circular column" has been chosen because a column usually includes a base portion, a capital portion, and a bearer portion interconnecting the base portion with the capital portion, all of which are characteristic of the present invention

2

when viewed in longitudinal cross section as shown in FIGURE 2. Since the column is endless, i.e., extends over 360°, the term circular column is used herein to designate the rotor structure of the present invention.

5 The use of the circular column structure makes it possible to separate different systems at one and same disk-like structure from each other in such a manner that a compressor system can be placed, at the same radius as a turbine rotor, either with direct or indirect passage
10 along the radius, below the turbine blade rim.

In the two figures of the drawing the steam turbine housing is generally designated by reference numeral 10 while the rotor structure or circular column is designated therein by reference numeral 20. The rotor or circular
15 column structure 20 includes radially inwardly thereof a base portion 21 provided with a radially inner steam turbine generally designated by reference numeral 22 and including suitably shaped conventional turbine blades 23. The bearer portion 24 connects the base portion
20 21 with the capital portion 26 of the circular column or rotor structure 20. On both sides of the bearer structure suitably shaped blades 25 are secured in any conventional manner at the bearer portion 24. The capital portion 26 is provided radially outwardly thereof with
25 a second turbine stage generally designated by reference numeral 27 and including turbine blades 28. The second turbine stage 27 rotates within the dome-shaped space 19 (FIG. 1) provided in the radially outward portion of the housing 10.

30 Steam is supplied to the first turbine stage 22 through supply apertures 11 which are suitably shaped, for example, in the form of nozzles as shown in FIGURE 2. The inlet apertures 11 are provided within the area of the first turbine stage that is closed off by the circular
35 segment 18 suitably secured to a lateral housing part. After passing through the closed portion of the first turbine stage, the steam expands radially outwardly within the area B opposite the closed area 18, into the regions of the radial compressor blades 25. Since the
40 blades 25 rotate in unison with the rotor or circular column structure 20, the steam is regenerated and subsequently permitted to flow through guide channels 12 and nozzle-shaped apertures 13 into the dome-shaped
45 space 19 for acting on the blades 28 of the second turbine stage 27. The channels 12 are constituted by the triangle shape of the capital portion 26 and the outwardly flared wall portions 14 of the housing.

The regenerated steam thus admitted to the second turbine stage gives off energy for the drive of the rotor or circular columns structure 20 in the same direction
50 as is effected by the first turbine stage. After thus driving the rotor structure 20, the steam leaves the turbine through conventional outlets O schematically indicated in FIGURE 1.

55 From the foregoing description, it is obvious that the steam is initially used for the drive of the first turbine stage, the used steam is regenerated in the compressor and is used again after regeneration in the second turbine stage. With increasing length of the radius
60 the output of the steam is increased, in addition to the regeneration through the radial compressor, by the improved leverage that takes place.

It can also be readily seen that the steam is thrown
65 outwardly by the centrifugal force out of the blade rim of the first turbine stage by the use of only a partial radially outer housing wall for the first turbine stage. In this manner, the steam is seized in the channel provided in the housing within the area of the bearing portion 14,
70 is regenerated and then passes over into the dome-shaped space 19 where it acts on the further blade rim of the same rotor structure.

I claim:

1. A steam turbine having an axis of rotation, comprising:

housing means,

rotor means rotatably supported within said housing means and constituted by a circular column, said rotor means including first turbine means, compressor means disposed radially outwardly of said first turbine means and second turbine means disposed radially outwardly of said compressor means,

supply means for supplying steam to said first turbine means to impart rotary movement to said rotor means in one direction,

further means including said compressor means for regenerating the steam used by said first turbine means,

and means for conducting the regenerated steam from said compressor means to said second turbine means to act upon said second turbine means in the direction of rotation of said rotor means.

2. A steam turbine according to claim 1, wherein said circular columns forming said rotor means includes base, bearer and capital portions, the base portions being provided with a first blade rim forming said first turbine means, said bearer portion being provided with blade means forming the compressor means, and the capital portion being provided with a second blade rim forming said second turbine means.

3. A steam turbine according to claim 2, wherein said conducting means includes channel means in said housing means for conducting the regenerated steam from said compressor means past the capital portion of the circular column to said second turbine means.

4. A steam turbine according to claim 3, wherein said further means includes wall means extending about only a portion of the circumference of said first turbine means to permit the steam used by said first turbine means to be driven in the radially outward direction while passing through said compressor means.

5. A steam turbine according to claim 1, wherein said conducting means includes channel means in said housing means for conducting the regenerated steam from said compressor means past the capital portion of the circular column to said second turbine means.

6. A steam turbine according to claim 1, wherein said further means includes wall means extending about only a portion of the circumference of said first turbine means to permit the steam used by said first turbine means to be driven in the radially outward direction while passing through said compressor means.

References Cited by the Examiner

FOREIGN PATENTS

12,950 18/84 Great Britain.

JOSEPH H. BRANSON, JR., *Primary Examiner.*