

No. 675,034.

Patented May 28, 1901.

C. CHAUNCEY.
SAW GUMMER.

(Application filed Jan. 26, 1901.)

(No Model.)

Fig. 1.

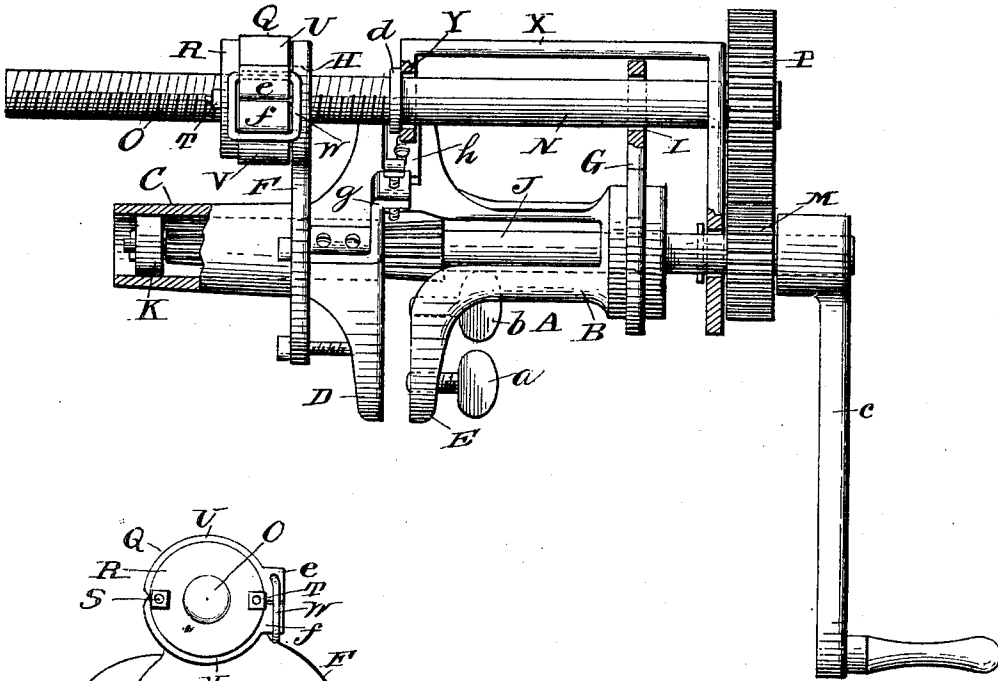

Fig. 2.

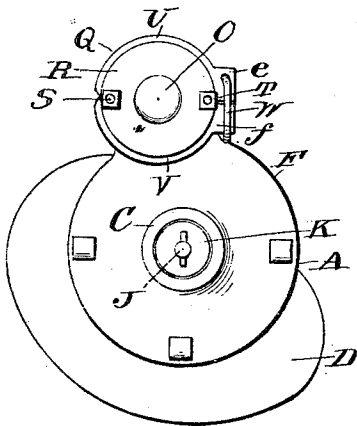
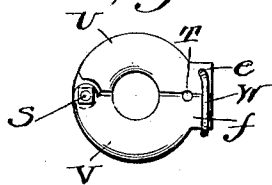

Fig. 3.



Witnesses

Just H. Blackwood
Albert B. Blackwood

Inventor

Chauncey Chauncey
per *Nathan Bierford*
Attorney

UNITED STATES PATENT OFFICE.

CLAYTON CHAUNCEY, OF WAYNESBORO, TENNESSEE.

SAW-GUMMER.

SPECIFICATION forming part of Letters Patent No. 675,034, dated May 28, 1901.

Application filed January 26, 1901. Serial No. 44,847. (No model.)

To all whom it may concern:

Be it known that I, CLAYTON CHAUNCEY, a citizen of the United States of America, and a resident of Waynesboro, county of Wayne, State of Tennessee, have invented certain new and useful Improvements in Saw-Gummers, of which the following is a specification.

My invention relates to an improved machine for gumming saws which is adapted to be secured directly upon the saw-blade and in which the reamer or cutting-tool is adapted to move transversely of the saw-blade as the cutting operation progresses, and thereby continually presenting a larger portion of said reamer to the saw.

The invention has for its object to provide a saw-gummer which is simple and inexpensive in construction, easy to operate, and very durable and in which the reamer is automatically fed transversely to the saw with a constant and definite movement.

It has also for its object to provide means for varying the speed of the feed-screw and reamer and in placing the feed-screw in such a position that it will be out of the way of the cuttings from the saw, and thereby prevent the screw-thread from being clogged by said cuttings.

In the accompanying drawings, Figure 1 is a side elevation. Fig. 2 is an end elevation. Fig. 3 is a detail view of the clamping feed-nut.

In the drawings, in which like letters of reference denote like parts throughout the several views, A represents the main frame or casting of the saw-gummer, having cylindrical portions B C and clamping-jaws D and E, provided with set-screws *a b*, by which the gummer is to be clamped rigidly upon the saw. Brackets F and G are secured to or cast with the main frame A and are provided with apertures H and I, respectively.

J is a shaft, one end having a slidible sleeve K, adapted to slide in the cylindrical portion C, and a tapering reamer, and the opposite end extending through and being supported in the lower portion of the bracket G and provided with a gear-wheel M and a crank-handle *c*.

N is the feed-shaft, provided, preferably, with coarse screw-threads O at one end, ter-

minating in a shoulder *d*, said screw-threads passing loosely through the aperture H of the bracket F and the opposite end of said feed-shaft, passing through the aperture I of the bracket G and provided with a gear-wheel P, preferably larger in diameter than the gear-wheel M, for the purpose of driving the shaft J, that carries the reamer, at a greater speed than the feed-shaft N.

Q is a clamping-nut provided with lugs *e* and *f* and internally screw-threaded to receive the screw of the feed-shaft.

R is a plate.

The clamping-nut is securely held between the bracket F and the plate R by bolts S and T and consists of two parts or halves U and V, pivoted on the bolt S and provided with a link W, one end pivoted to the lug *e* of the clamping-nut and the other end adapted to engage the lug *f* thereof, and thereby hold the two parts of the clamping-nut together and secure the same on the screw of the feed-shaft.

X is a brace which slides on the top of the bracket G, one end provided with a depending arm Y, having an aperture adapted to be mounted on the feed-shaft and abut against the shoulder *d*, and the opposite end having an arm provided with apertures through which the reamer and feed shafts are adapted to pass. The purpose of the brace X is to keep all the parts in line and the gear-wheel in alinement, and by reason of the said brace sliding on the top of the bracket G sidewise movement of the feed-shaft is prevented.

g and *h* are adjustable clamping-plates for engaging and clamping the tooth of the saw when the saw-gummer is applied thereto.

The feeding or transverse movement of the reamer is regulated by the size of the screw-threads on the feed-shaft—the larger or coarser the screw-threads the faster it will feed, the finer the screw-thread the slower it will feed. The screw-threads of the nut Q should correspond in size to the screw-thread of the feed-shaft, so that whenever the size of the screw-thread of the feed-shaft is changed the nut Q has to be changed.

It will be seen that by my invention the feed-shaft is out of the way of all cuttings from the saw and that by operating the shaft that

carries the reamer the feed-shaft is automatically operated and also that by reason of the transverse movement of the reamer-shaft different portions of the reamer are successively
 5 presented to the saw, and thereby it is prevented from wearing out or getting dull at any one point, which would be the case if the reamer did not have the transverse movement and the gradual cutting of the saw by the
 10 transverse movement of the reamer makes a very true and smooth tooth and does not tend to break the teeth of the saw. I do not wish to be limited to the precise construction as herein shown, as the same may be varied some-
 15 what without departing from the spirit of my invention.

The operation is as follows: The reamer having been arranged so that its small end is on a line with the slot formed between the
 20 jaws D and E, the saw is clamped therein by the set-screws *a b*, with one side of the reamer resting in the throat of the tooth. Then by turning the crank-handle *c* the shaft J and its reamer are rotated and at the same time
 25 moved transversely or longitudinally toward the saw by means of the screw of the feed-shaft. The reamer being held constantly in the same axial line by the slidable sleeve K makes circular cuts of increasing radius in
 30 the saw with each succeeding revolution, and the operation continues until the desired amount of metal has been removed. The clamping-nut is then opened, and the feed-shaft and reamer are slid back to their normal
 35 positions. The clamping-nut is then closed around the screw-threads of the feed-shaft, and the machine is again ready for use.

Having thus described my invention, what I claim is—

40 1. A device for gumming saws comprising a frame with a slot to receive a saw, a shaft having a reamer, said frame having brackets extending therefrom, a feed-shaft mounted in
 45 said brackets, and a slidable brace with an arm at each end, one of the arms embracing the feed-shaft and the other arm embracing

the feed and reamer shafts, substantially as described.

2. A device for gumming saws comprising a frame having a slot to receive a saw, a shaft
 50 having a reamer, a screw-threaded feed-shaft provided with an annular shoulder, and a slidable brace having arms at its opposite ends, one of said arms embracing the feed-shaft and
 55 abutting against the annular shoulder thereof, and the other arm embracing one end of the reamer-shaft, and means for communicating motion from one of said shafts to the other, substantially as described.

3. A device for gumming saws comprising a
 60 frame with a slot to receive a saw, a shaft having a reamer, said frame provided with brackets one of which is provided with a clamping-nut, a feed-shaft mounted in said
 65 brackets and engaging said clamping-nut, and a brace slidable on one of the brackets and provided with arms which extend downward on opposite sides of said bracket, said arms
 70 embracing the feed and reamer shafts, substantially as described.

4. A device for gumming saws comprising a
 75 frame having a slot to receive a saw, clamping-plates for engaging the teeth of a saw, said frame having upwardly-extending brackets, a feed-shaft mounted in said brackets and
 80 provided with an annular shoulder, an internally-screw-threaded two-part nut attached to one of said brackets, a link for securing said parts together, and a slidable brace with
 85 a depending arm at each end, one of said arms embracing the feed-shaft and abutting against the annular shoulder thereof, and the other arm embracing the feed and reamer shafts, and means for communicating motion from one of said shafts to the other, substantially
 as described.

Signed by me at Waynesboro, Tennessee,
 this 14th day of January, 1901.

CLAYTON CHAUNCEY.

Witnesses:

E. D. MCGLAMERY,
 T. J. WHITBY.