

July 9, 1935.

L. R. RUTHERFORD

2,007,694

FIRE KINDLER

Filed Oct. 23, 1933

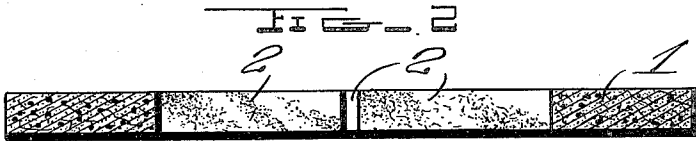
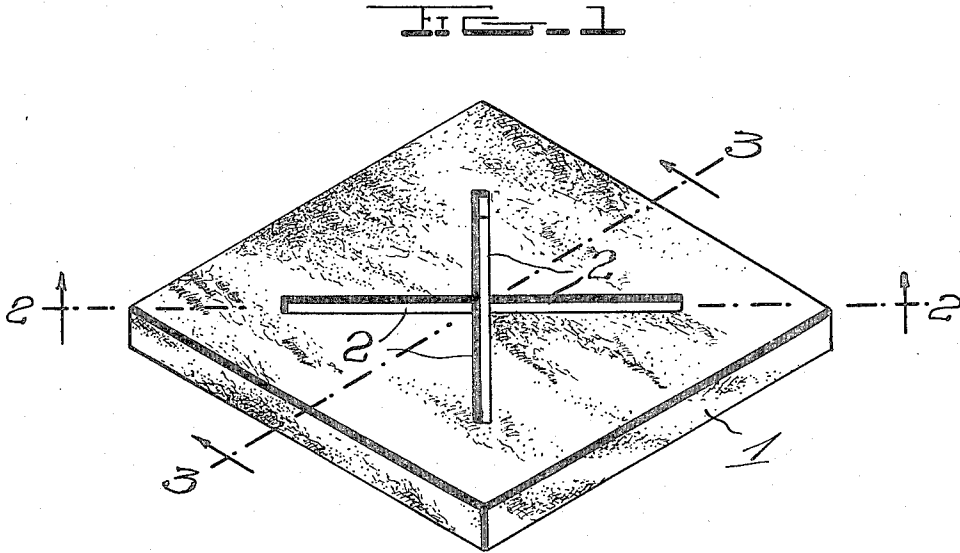

Inventor

Lewis R. Rutherford,

By *Jacobi & Jacobi*

Attorneys

UNITED STATES PATENT OFFICE

2,007,694

FIRE KINDLER

Lewis R. Rutherford, Louisville, Ky.

Application October 23, 1933, Serial No. 694,859

5 Claims. (Cl. 44-41)

This invention relates to a fire starter or kindler and one object of the invention is to provide a device of this character formed of materials which can be readily ignited and will burn for a sufficient length of time to insure starting of either a wood or coal fire.

Another object of the invention is to so form the fire starter that when made, it will be in the form of a hard block of determined dimensions consisting of vegetable fibers saturated with a combustible binder and compressed to a determined thickness and density. Therefore, only a predetermined quantity of binder will be contained in the compressed block.

A still further object of the invention is the provision of a fire starter which is water proof and will not deteriorate when stored away or be affected by atmospheric temperatures during warm weather.

Another object of the invention is to provide the fire starter with passages of such form that when the block is ignited, air may pass through the block to aid combustion and flame rapidly spread over the entire surface of the block.

A still further object of the invention is to provide a device of this character which when lighted in order to start a fire will be completely consumed and pass through the grate with ashes of the fire.

Still another object of the invention resides in providing a device which is simple and durable in construction, inexpensive to manufacture and one which will be very efficient in application to use.

With these and numerous other objects in view, my invention consists in the novel features of construction, combination and arrangement of parts as will be hereinafter referred to and more particularly pointed out in the specification and claims.

In the accompanying drawing forming a part of this application:

Figure 1 is a perspective view of the improved fire starter;

Figure 2 is a section taken along the line 2-2 of Figure 1; and

Figure 3 is a section taken along the line 3-3 of Figure 1.

In describing the invention, I shall refer to the drawing in which similar reference characters designate corresponding parts throughout the several views and in which the improved fire starter or kindler consists of a block or body 1 formed of vegetable fibers compressed to the desired shape and density and saturated with a

combustible binder. In the present illustration, this block is square when viewed in top plan and of approximately five inches along a side and one-half of an inch thick. It is to be understood, however, that the block may be of other shapes and dimensions if so desired.

The block is formed of finely divided vegetable fibers which may be wood pulp, paper pulp, corn stalk pulp, sugar cane pulp, free cotton, or any other vegetable fibers found suitable. In one embodiment of the invention, pulp is thoroughly saturated with a combustible binder which is preferably paraffin heated to a melted state and the mass of saturated pulp placed in a press and compressed under determined pressure to form the shaped block. During compression, excess binder will be expelled and, therefore, the finished block will be of predetermined thickness and density and contain a predetermined quantity of binder which becomes hard as it cools and securely binds the fibers together and forms a hard block which is free from dust and will not soil the hands or clothing of a person handling the fire starters. It should also be noted that the blocks will not crumble and also that since the paraffin will not melt under temperatures existing during hot weather, there will be no danger of fires due to spontaneous combustion when a number of the starters are stored away by a merchant or user.

Instead of soaking the pulp with paraffin before molding it into the blocks, the blocks may be cut from prepared stock of the proper thickness and density, such as vegetable fiber-board, and these blocks then soaked in hot paraffin until they have absorbed all the paraffin they can take up. In either case, the blocks will only be able to retain a predetermined quantity of paraffin.

The central portion of the block is formed with a pair of slots 2 which extend between corners of the block in crossed relation to each other and intersect at the center of the block. These slots are each approximately four and one-half inches long and three-sixteenths of an inch wide in the illustrated embodiment, but it is to be understood that the dimensions may be varied. The slots may be formed when cutting or molding the blocks or the blocks first formed and then cut to provide the slots.

By forming the block with the crossed slots ventilation is provided through the block to aid combustion when the block is ignited and it should also be noted that when the fire starter is ignited it can burn along edges of the slots as well as along side edges of the block and the

flame will quickly spread over the entire surface of the block and result in a large flame which will effectively ignite coal, wood or other fuel in a stove or furnace. The fire starter itself will be completely consumed and pass through the grate with the ashes and there will be no danger of it clogging the grate and causing it to be broken when shaken.

While I have shown in the drawing slots 2 cut diagonally into the block 1, which structure is probably preferable, it will be understood that I am not limited to the diagonal cutting of the slots in the block, and the same may be cut otherwise with the slots intersection.

From the foregoing description of the construction of my improved device, the operation thereof and the method of applying the same to use will be readily understood. It will be seen that I have provided a simple, inexpensive and efficient means for carrying out the objects of the invention. While I have particularly described the elements best adapted to perform the functions set forth, it is obvious that various changes in form, proportion and in the minor details of construction may be resorted to without departing from the spirit or sacrificing any of the principles of the invention.

Having thus described the invention, what is claimed is:

1. As an article of manufacture, a fire kindler comprising a relatively flat block formed of vegetable fibers compressed to a predetermined density and thickness and having its intermediate portion formed with slots extending through the block and intersecting at substantially the center thereof, the ends of said slots terminating short of the edges of said block and said block being saturated with a predetermined quantity of paraffin.

2. As an article of manufacture, a fire kindler comprising a relatively flat block formed of vegetable fibers compressed to a predetermined density and thickness and having its intermediate portion formed with slots extending diagonally through the block and intersecting at substantially the center thereof, the ends of said slots terminating short of the edges of said block and said block being saturated with a predetermined quantity of paraffin.

3. The process of making a fire kindler including the formation of a block of vegetable fibers compressed to a predetermined thickness and density, punching diagonal and intersecting slots therethrough in a predetermined relation to the edges of said block, saturating the slotted block to its capacity with hot paraffin, and causing the paraffin to harden in the block by cooling.

4. The process of making a fire kindler from vegetable-fiber board consisting in punching intersecting slots completely through a section of said vegetable-fiber board so that the ends of said slots terminate short of the edges of said board, saturating the slotted board to its capacity with hot paraffin, and causing the paraffin to harden in the board by cooling whereby the board is sealed against moisture.

5. As an article of manufacture, a fire kindler comprising a relatively flat block formed of vegetable fibers compressed to a predetermined density and thickness and having its intermediate portion formed with slots extending through the block and intersecting at substantially the center thereof, the ends of said slots terminating short of the edges and said block being saturated with a predetermined quantity of melted inflammable substance.

LEWIS R. RUTHERFORD.