

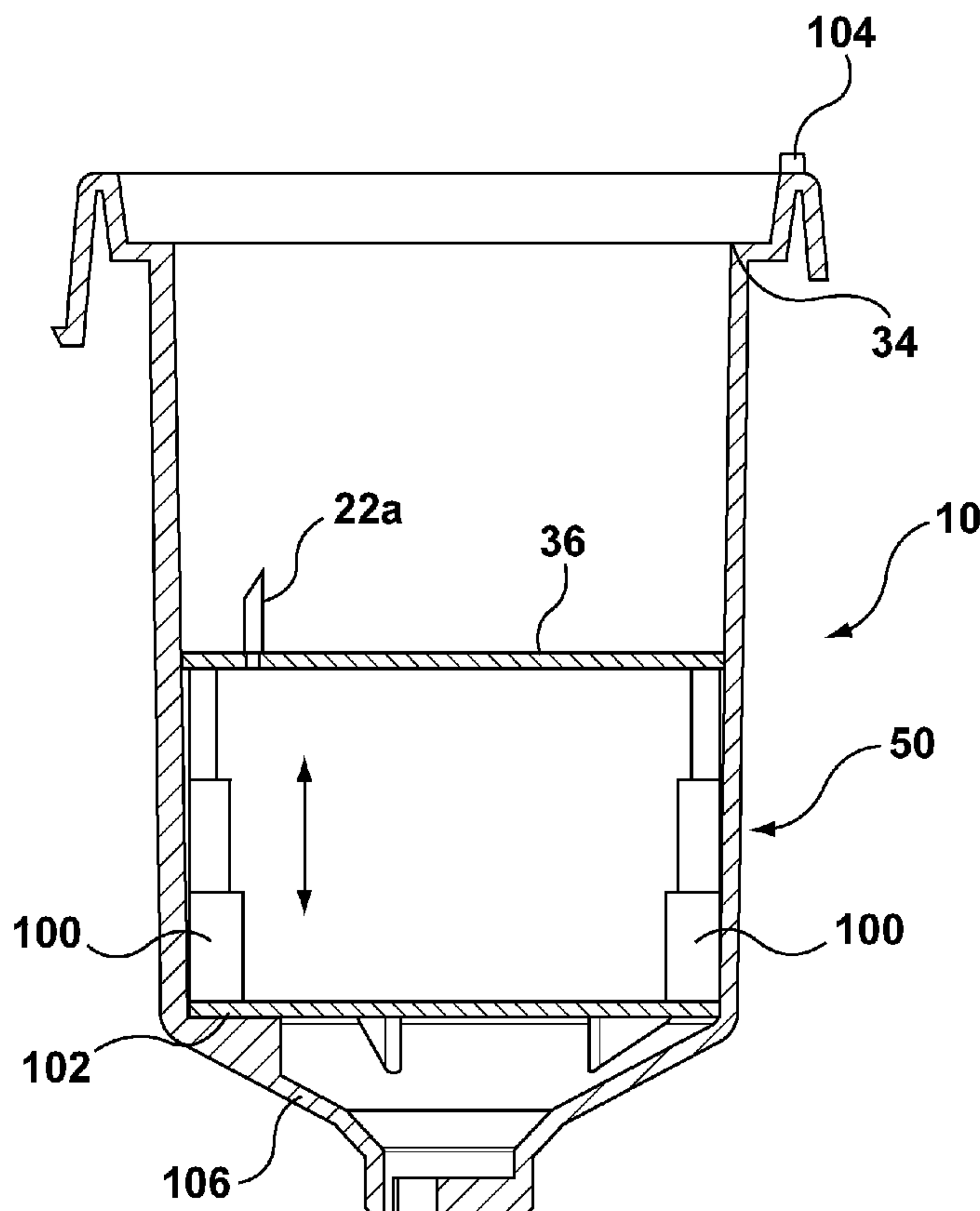

(86) **Date de dépôt PCT/PCT Filing Date:** 2014/05/23
 (87) **Date publication PCT/PCT Publication Date:** 2014/11/27
 (45) **Date de délivrance/Issue Date:** 2017/02/07
 (85) **Entrée phase nationale/National Entry:** 2015/11/17
 (86) **N° demande PCT/PCT Application No.:** CA 2014/050477
 (87) **N° publication PCT/PCT Publication No.:** 2014/186897
 (30) **Priorité/Priority:** 2013/05/23 (US61/826,777)

(51) **Cl.Int./Int.Cl. A47J 31/44** (2006.01),
A47J 31/06 (2006.01), **A47J 36/16** (2006.01),
B65D 85/804 (2006.01)
 (72) **Inventeurs/Inventors:**
 TROMBETTA, LIBERATORE A., CA;
 MEFFEN, CHRISTOPHER DOUGLAS, CA;
 FU, YUCHENG, CA
 (73) **Propriétaire/Owner:**
 2266170 ONTARIO INC., CA
 (74) **Agent:** RIDOUT & MAYBEE LLP

(54) **Titre : LOGEMENT DE CAPSULE**
 (54) **Title: CAPSULE HOUSING**



(57) **Abrégé/Abstract:**

A capsule housing is provided for use in a machine for preparing a desired product from capsules. The capsule housing includes a capsule containment portion, a product collection portion and a product dispensing portion. A dispensing system is disposed in the capsule housing for dispensing product prepared from the capsule. An adjustment system is disposed in the capsule housing for accommodating different sizes of capsules.

(12) INTERNATIONAL APPLICATION PUBLISHED UNDER THE PATENT COOPERATION TREATY (PCT)

(19) World Intellectual Property
Organization
International Bureau(10) International Publication Number
WO 2014/186897 A1(43) International Publication Date
27 November 2014 (27.11.2014)

(51) International Patent Classification:

A47J 31/44 (2006.01) A47J 36/16 (2006.01)
A47J 31/06 (2006.01) B65D 85/804 (2006.01)

(21) International Application Number:

PCT/CA2014/050477

(22) International Filing Date:

23 May 2014 (23.05.2014)

(25) Filing Language:

English

(26) Publication Language:

English

(30) Priority Data:

61/826,777 23 May 2013 (23.05.2013) US

(71) Applicant: **2266170 ONTARIO INC.** [CA/CA]; 2530 Stanfield Road, Mississauga, Ontario L4Y 1S4 (CA).(72) Inventors: **TROMBETTA, Liberatore, A.**; 525 Golflinks Road, Ancaster, Ontario L9G 4X6 (CA). **MEFFEN, Christopher, Douglas**; 16 Emily Carr Crescent, Bolton, Ontario L7E 2L1 (CA). **FU, Yucheng**; 3379 Oakglade Crescent, Mississauga, Ontario L5C 1X4 (CA).(74) Agents: **RIDOUT & MAYBEE LLP** et al.; 2000 Argenta Road, Plaza 1, Suite 301, Mississauga, Ontario L5N 1P7 (CA).(81) Designated States (*unless otherwise indicated, for every kind of national protection available*): AE, AG, AL, AM, AO, AT, AU, AZ, BA, BB, BG, BH, BN, BR, BW, BY, BZ, CA, CH, CL, CN, CO, CR, CU, CZ, DE, DK, DM, DO, DZ, EC, EE, EG, ES, FI, GB, GD, GE, GH, GM, GT, HN, HR, HU, ID, IL, IN, IR, IS, JP, KE, KG, KN, KP, KR, KZ, LA, LC, LK, LR, LS, LT, LU, LY, MA, MD, ME, MG, MK, MN, MW, MX, MY, MZ, NA, NG, NI, NO, NZ, OM, PA, PE, PG, PH, PL, PT, QA, RO, RS, RU, RW, SA, SC, SD, SE, SG, SK, SL, SM, ST, SV, SY, TH, TJ, TM, TN, TR, TT, TZ, UA, UG, US, UZ, VC, VN, ZA, ZM, ZW.(84) Designated States (*unless otherwise indicated, for every kind of regional protection available*): ARIPO (BW, GH, GM, KE, LR, LS, MW, MZ, NA, RW, SD, SL, SZ, TZ, UG, ZM, ZW), Eurasian (AM, AZ, BY, KG, KZ, RU, TJ, TM), European (AL, AT, BE, BG, CH, CY, CZ, DE, DK, EE, ES, FI, FR, GB, GR, HR, HU, IE, IS, IT, LT, LU, LV,

[Continued on next page]

(54) Title: CAPSULE HOUSING

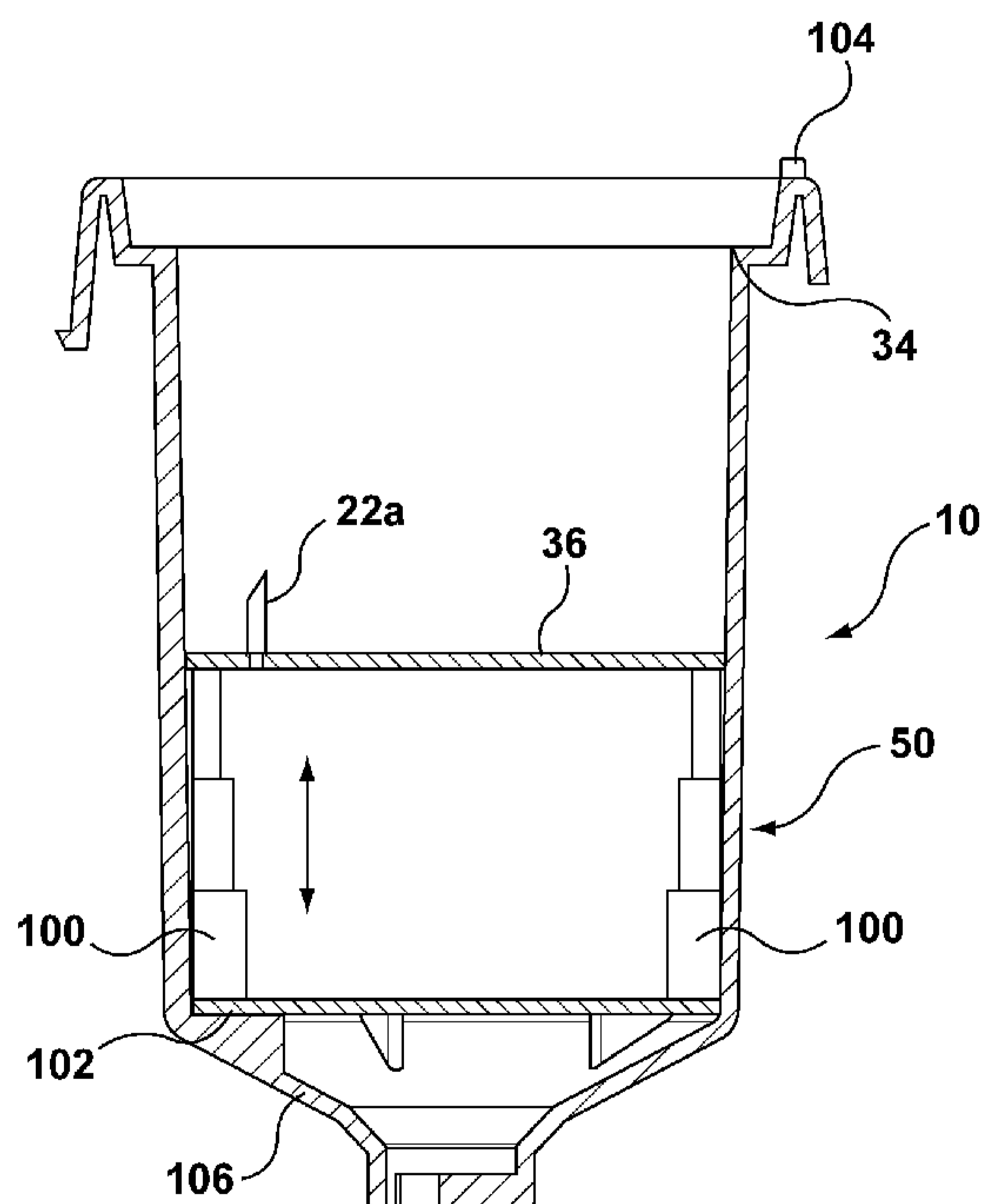

FIG. 13

(57) Abstract: A capsule housing is provided for use in a machine for preparing a desired product from capsules. The capsule housing includes a capsule containment portion, a product collection portion and a product dispensing portion. A dispensing system is disposed in the capsule housing for dispensing product prepared from the capsule. An adjustment system is disposed in the capsule housing for accommodating different sizes of capsules.

WO 2014/186897 A1 

MC, MK, MT, NL, NO, PL, PT, RO, RS, SE, SI, SK, **Published:**
SM, TR), OAPI (BF, BJ, CF, CG, CI, CM, GA, GN, GQ, — *with international search report (Art. 21(3))*
GW, KM, ML, MR, NE, SN, TD, TG).

TITLE: CAPSULE HOUSING**FIELD**

[0001] This specification relates to machines that are adapted to prepare consumable products from capsules and in particular to housings adapted for receiving capsules for such machines.

BACKGROUND

[0002] The following background discussion is not an admission that anything discussed below is citable as prior art or common general knowledge.

[0003] Machines for preparing products, such as beverages like coffee or tea, from single use capsules are becoming increasingly popular. Such machines typically include a brew chamber having a capsule housing that is adapted for receiving a specific capsule. The capsule is supported within the capsule housing while a fluid such as hot water is injected into the capsule to mix with ingredients contained within the capsule. A resulting prepared product is subsequently dispensed from the capsule into a desired receptacle such as a cup or bowl.

[0004] A problem with such machines is that the capsule housing is only adapted to receive one specific size or shape of capsule. This limits the options available to consumers to prepare a desired product. Accommodating multiple capsule sizes or shapes is a challenge since the capsule housing requires sufficiently close tolerances to support the capsule during injection of fluid and extraction of the prepared product.

[0005] Another problem with such machines is that the capsule housing is not adapted to receive larger volume capsules. This limits the options available to consumers to prepare products having a larger volume of required ingredients (such as products with noodles or other insoluble consumable ingredients).

[0006] It is desirable to provide a capsule housing that is adapted to receive larger volume capsules and preferably multiple capsule sizes or shapes while maintaining the close tolerances required to adequately support each capsule.

SUMMARY

[0007] In one aspect the invention provides a capsule housing for a machine that prepares a product from a capsule, the capsule housing comprising:

a capsule containment portion defining a cavity adapted for receiving a capsule;
a product dispensing portion defining an opening adapted for dispensing product from said capsule housing to a desired receptacle;
a dispensing system adapted for piercing a capsule to dispense product from said capsule to said product dispensing portion; and
an adjustment system adapted to adjust one or more dimensions of said capsule containment portion.

[0008] In another aspect, the invention provides a capsule housing for a machine that prepares a product from a capsule, the capsule housing comprising:

an attachment structure for removably attaching said capsule housing to a support structure disposed on the machine;
a capsule containment portion defining a cavity adapted for receiving a capsule;
a product dispensing portion defining an opening adapted for dispensing product from said capsule housing to a desired receptacle; and
a dispensing system adapted for piercing a capsule to dispense product from said capsule to said product dispensing portion.

[0009] Other aspects and features of the teachings disclosed herein will become apparent, to those ordinarily skilled in the art, upon review of the following description of the specific examples of the specification.

DRAWINGS

[0010] The drawings included herewith are for illustrating various examples of articles, methods, and apparatuses of the present specification and are not intended to limit the scope of what is taught in any way. For simplicity and clarity of illustration, where considered appropriate, reference numerals may be repeated among the drawings to indicate corresponding or analogous elements.

[0011] Figure 1 is a schematic view of a capsule housing in accordance with the present invention disposed in a machine for preparing a desired product from capsules;

[0012] Figure 2 is a top view of the capsule housing of Figure 1;

[0013] Figure 3 is a vertical sectional view of the capsule housing as viewed along lines 3-3 of Figure 2 with a capsule loaded into the capsule housing;

[0014] Figure 4 is a top view of the support structure disposed in a machine for receiving the capsule housing of Figure 1;

[0015] Figure 5 is an exploded view of an alternative embodiment of a capsule housing in accordance with the present invention;

[0016] Figure 6 is a top view of the capsule housing shown in Figure 5;

[0017] Figure 7 is an exploded view of an alternative embodiment of a capsule housing in accordance with the present invention;

[0018] Figure 8 is a sectional view of the capsule housing (no longer exploded) as viewed along lines 8-8 in Figure 7;

[0019] Figure 9 is a vertical sectional view of an alternative embodiment of a capsule housing in accordance with the present invention;

[0020] Figure 10 is a cross sectional view of the alternative embodiment of capsule housing as viewed along lines 10-10 of Figure 9;

[0021] Figure 11 is a side view of a capsule adapted for fitting into the capsule housing of figures 9 and 10;

[0022] Figure 12 is an exploded vertical sectional view of an alternative embodiment of a capsule housing in accordance with the present invention; and

[0023] Figure 13 is a vertical sectional view of an alternative embodiment of a capsule housing in accordance with the present invention.

DESCRIPTION OF VARIOUS EMBODIMENTS

[0024] Various apparatuses or methods will be described below to provide examples of the claimed invention. The claimed invention is not limited to apparatuses or methods having all of the features of any one apparatus or method described below or to features common to multiple or all of the apparatuses described below. The claimed invention may reside in a combination or sub-combination of the apparatus elements or method steps described below. It is possible that an apparatus or method described below is not an example of the claimed invention. The applicant(s), inventor(s) and/or owner(s) reserve all rights in any invention disclosed in an apparatus or method described below that is not claimed in this document and do not abandon, disclaim or dedicate to the public any such invention by its disclosure in this document.

[0025] A capsule housing in accordance with the present invention is shown generally at 10 in the Figures.

[0026] Capsule housing 10 is adapted to receive a capsule 12 for preparing a desired product in a machine 14 (as shown schematically in Figure 1). Machine 14 includes a brew chamber having an injection system 16 for injecting a desired fluid, such as water, into capsule 12 for preparing a desired product. Machine 14 further includes a support structure 18 that is adapted to support capsule housing 10.

[0027] Capsule housing 10 includes an attachment structure 20 for attaching capsule housing 10 to support structure 18. Attachment structure 20

may include a collar 20a with one or more spring biased tabs 20b that are adapted to be removably disposed within corresponding slots 18a defined in support structure 18 (see Figure 4).

[0028] A dispensing system 22 may be disposed in capsule housing 10 for dispensing product from capsule 12. Dispensing system 22 may comprise a hollow probe 22a that is adapted to pierce capsule 12.

[0029] Capsule housing 10 comprises a hollow body having a capsule containment portion 24, a product collection portion 26 and a product dispensing portion 28.

[0030] Capsule containment portion 24 has a side wall 30 that defines a cavity 32 for receiving capsule 12. Capsule containment portion 24 may further include a seat 34 for supporting a first portion of capsule 12 within interior space 20 and a base 36 for supporting a second portion of capsule 10 within capsule containment portion 24.

[0031] Product collection portion 26 has a side wall 38 that defines a chamber 40 for collecting product that is prepared from capsule 12. Side wall 38 tapers inwardly from capsule containment portion 24 to direct product to product dispensing portion 28. Chamber 40 has a sufficient volume to allow product to flow from capsule 12 through product dispensing portion 28 without backup or over flow of product.

[0032] Product dispensing portion 28 defines an aperture 42 for dispensing product into a desired receptacle 44 such as a cup or bowl. Product dispensing portion 28 may include a sidewall 46 defining a cylindrical passage.

[0033] Capsule housing 10 as depicted in Figures 2 and 3 is adapted to receive a capsule 12, as shown in Figure 3, having a larger volume than conventional capsules. Capsule housing 10 is adapted to be retrofitted to existing machines (and in particular a K-Cup™ capsule machine sold by Keurig™). Side wall 30 of capsule housing extends with little or no taper from seat 34 to base 36

to define a capsule containment portion 24 of optimal volume. Additional volume is obtained by defining a shoulder 48 above seat 34.

[0034] Referring to Figures 5-13, an adjustment system 50 is provided to adjust the configuration of capsule housing 10 to accommodate capsules 12 of different heights, shapes or diameters at a desired position within capsule housing 10.

[0035] Referring to Figures 5 and 6, adjustment system 50 may be provided to adjust the shape or diameter of seat 34 to accommodate capsules 12 of different shapes or diameters. Adjustment system 50 may comprise an insert 52 that may be removably disposed within capsule housing 10. Insert 52 includes side wall 54 and seat 56 that define a capsule containment portion 24 sized to accommodate a desired shape or diameter of capsule 12. (in this instance, insert 52 includes a containment portion 24 that is adapted to receive a Keurig™ Vue™ style of capsule having an irregular shape). Insert 52 may further include dispensing system 22, such as hollow probe 22a, disposed in a location suitable for dispensing product from the particular shape or diameter of capsule 12 intended for use with insert 52.

[0036] Adjustment system 50 may also be provided to accommodate capsules 12 of different heights. Referring to Figures 7 and 8, one embodiment of adjustment system 50 for adjusting heights is shown. Capsule housing 10 comprises an outer sleeve 60 defining at least one outer track 62 and an inner sleeve 64 defining at least one inner track 66. Outer track 62 extends parallel to the axis A of capsule housing 10. Inner track 66 extends diagonally from a first height H1 to a second height H2. Tracks 62, 66 may be formed by raised bosses (such as outer track 62) or by a slot (such as inner track 66) or any other suitable structure for controlling movement over a desired path.

[0037] An adjustable base 68 is disposed within inner sleeve 64. Adjustable base 68 includes at least one runner 70 adapted for moving along both outer track 62 and inner track 66. In the embodiment depicted in Figures 7

and 8, four outer tracks 62 and four inner tracks 66 are provided with four corresponding runners 70 adapted to run in the tracks 62, 66.

[0038] A collar 72 is disposed over outer sleeve 60 to define seat 34 for supporting capsule 12. A slot 74 is defined in collar 72 for receiving a tab 76 extending from inner sleeve 64. Movement of tab 76 from one end of slot 74 to the other end of slot 74 causes inner sleeve 64 to rotate relative to outer sleeve 60. Because runner 70 is disposed in outer track 62, adjustable base 68 is prevented from rotating with inner sleeve 66. Rotation of inner sleeve 66 thus causes runner 70 to move along inner track 66 to move adjustable base 68 between first height H1 and second height H2. Inner track 66 further includes a ledge 78 at each end of track for supporting adjustable base 68 at first height H1 or second height H2 depending on positioning of tab 76.

[0039] Adjustable base 68 includes a dispensing system 22 such as hollow probe 22a. An aperture 80 is defined in adjustable base 68 to accommodate capsules 12 having an integral dispensing nozzle (not shown) rather than requiring dispensing probe 22a.

[0040] Referring to Figures 9-11, adjustment system 50 may instead comprise a plurality of support ribs 82 disposed in capsule containment portion 24. Support ribs 82 define a first support surface 84 for supporting smaller size capsules 12 of a first height, shape or diameter. Larger size capsules 12 may be configured with corresponding grooves 86 in their sidewall 88 to receive support ribs 82. Adjustment system 50 further comprises a base 36 for supporting such larger size capsules. Base 36 includes a dispensing system 22 with hollow probe 22a for piercing such larger size capsules. As a result, larger size capsules 12 may be rotatably inserted into capsule housing 10 until support ribs 82 are disposed in grooves 86 to allow capsule 12 to be lowered into capsule containment portion 24. It will be understood that adjustment system 50 may comprise a plurality of support ribs 82 with support surfaces 84 disposed at a plurality of heights or other dimensions (not shown) to support different sizes of capsules.

[0041] Referring to Figure 12, height adjustment system 50 may instead comprise a removable insert 90 that may be disposed within capsule containment portion 24 to accommodate a different height or shape of capsule.

[0042] Referring to Figure 13, another embodiment of height adjustment system 50 is shown. In this embodiment, base 36 is disposed on a telescoping platform 100 that may be raised or lowered by a linear actuator 102. Linear actuator may be triggered by switch 104 disposed on seat 34. Linear actuator may be electrically powered by a battery 106 disposed in capsule housing 10 or it may be wired directly to the control system for machine 14. When switch 104 senses that capsule 12 has been disposed in capsule housing 10 and brew chamber has been closed then linear actuator is activated to move base 36 to a position where dispensing system 22 is activated. For example, base 36 may be moved to a position where probe 22a pierces capsule 12 to dispense product.

[0043] While the above description provides examples of one or more processes or apparatuses, it will be appreciated that other processes or apparatuses may be within the scope of the accompanying claims.

CLAIMS

I/We claim:

1. A capsule housing for a machine that prepares a product from a capsule, the capsule housing comprising:
 - a capsule containment portion defining a cavity adapted for receiving the capsule;
 - a product dispensing portion defining an opening adapted for dispensing product from said capsule housing to a desired receptacle;
 - a dispensing system adapted for piercing the capsule to dispense product from said capsule to said product dispensing portion; and
 - an adjustment system adapted to adjust one or more dimensions of said capsule containment portion.
2. The capsule housing of claim 1, further comprising a product collection portion disposed between said capsule containment portion and said product dispensing portion, said product collection portion defining a chamber for collecting product that is prepared from said capsule and directing said product to said product dispensing portion.
3. The capsule housing as claimed in claim 1 or claim 2, wherein said dispensing system comprises a probe that is adapted for piercing a portion of said capsule.
4. The capsule housing of any one of claims 1 - 3, wherein said adjustment system comprises a base disposed within said capsule containment portion, said base being moveable between a plurality of positions to accommodate different sizes of capsules.
5. The capsule housing of claim 4, wherein said base is moveable along one or more tracks disposed in said capsule housing.

6. The capsule housing of claim 4 or claim 5, wherein said capsule housing comprises an outer sleeve defining at least one outer track and an inner sleeve defining at least one inner track, and wherein said base includes at least one runner that is adapted to move along both said inner track and said outer track between said plurality of positions.
7. The capsule housing of any one of claims 4 - 6, wherein said base is disposed on a telescoping platform that may be raised or lowered between said plurality of positions.
8. The capsule housing of claim 7 wherein said telescoping platform is raised or lowered by a linear actuator.
9. The capsule housing of any one of claims 4 - 8 wherein said dispensing system is disposed on said base.
10. The capsule housing of any one of claims 1 - 3, wherein said adjustment system comprises a plurality of support ribs disposed in said capsule containment portion, said support ribs defining a support surface for supporting capsules at a desired position, at least one of said support surfaces also supporting said dispensing system.
11. The capsule housing of claim 10, wherein said adjustment system further comprises a base disposed within said capsule containment portion, said base also including said dispensing system.
12. The capsule housing of any one of claims 1 - 3, wherein said adjustment system comprises at least one removable insert disposed in said capsule containment portion, said removable insert being inserted or removed from said capsule housing to accommodate different sizes of capsules.
13. The capsule housing of claim 12 wherein said removable insert also includes said dispensing system.

14. The capsule housing of any one of claims 1 - 3, wherein said adjustment system comprises at least one removeable insert disposed in said capsule containment portion, said removeable insert defining said capsule containment portion, said removable insert being inserted or removed from said capsule housing to accommodate different sizes of capsules.

15. The capsule housing of claim 14 wherein said removable insert also includes said dispensing system.

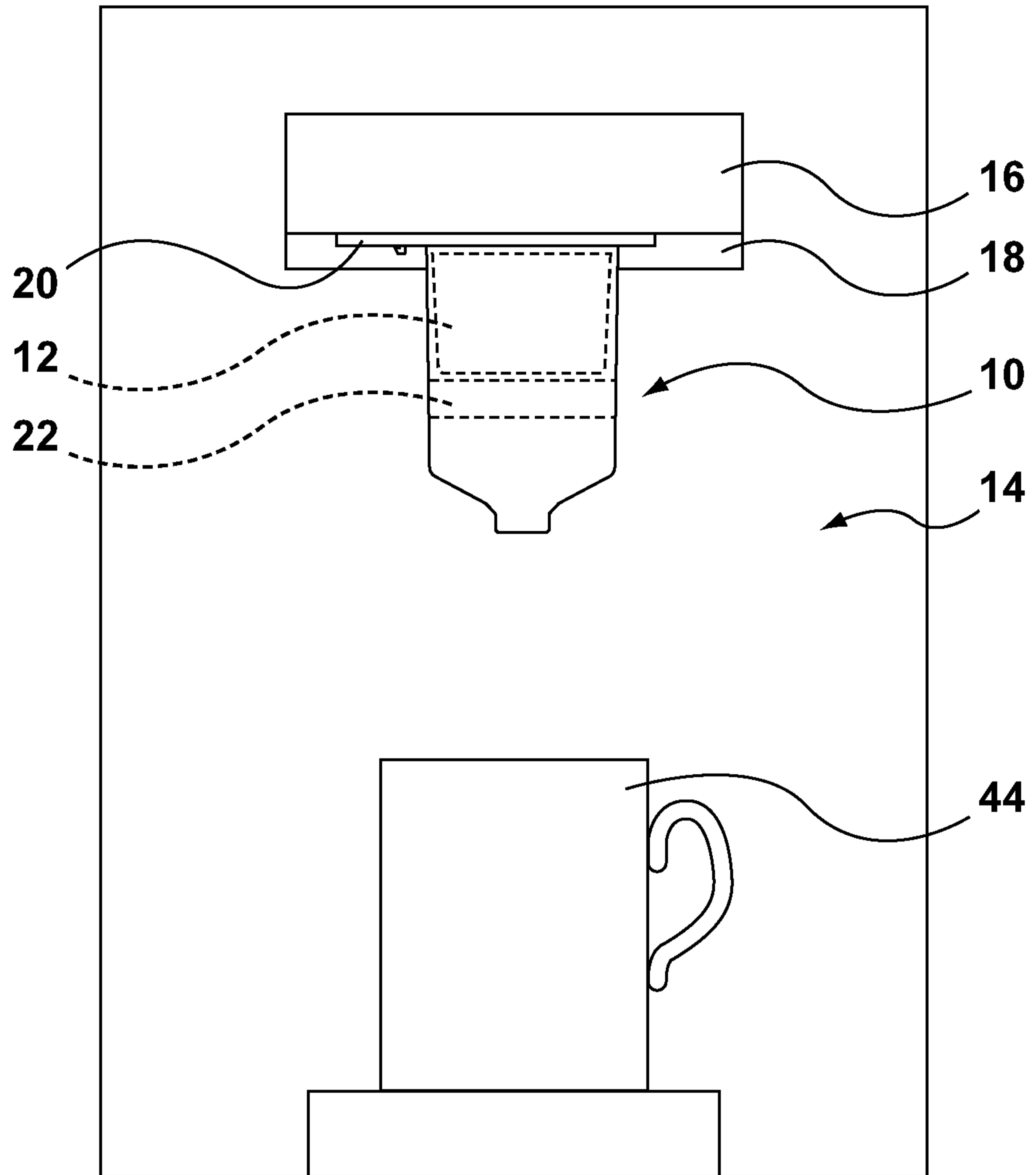

FIG. 1

2/11

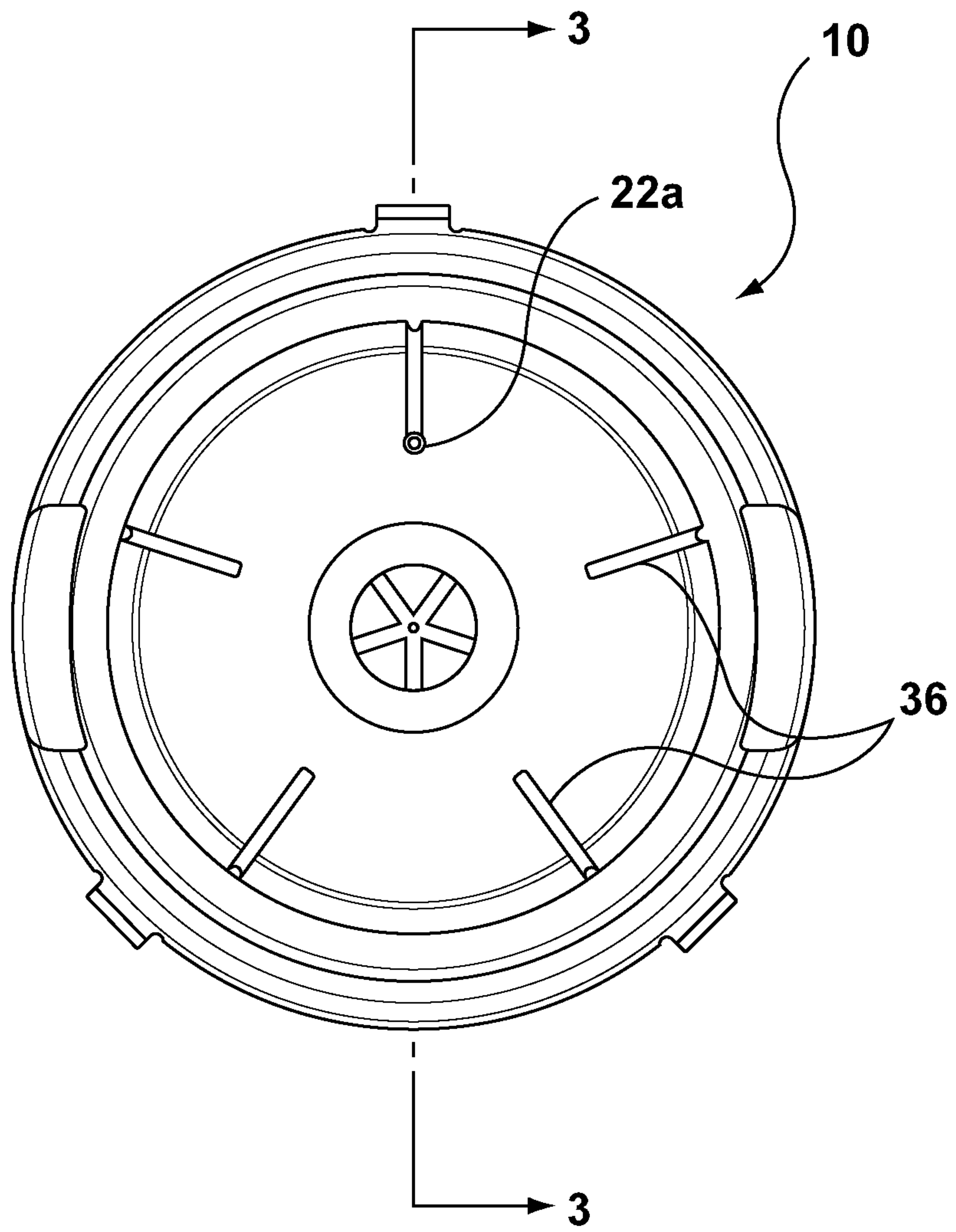

FIG. 2

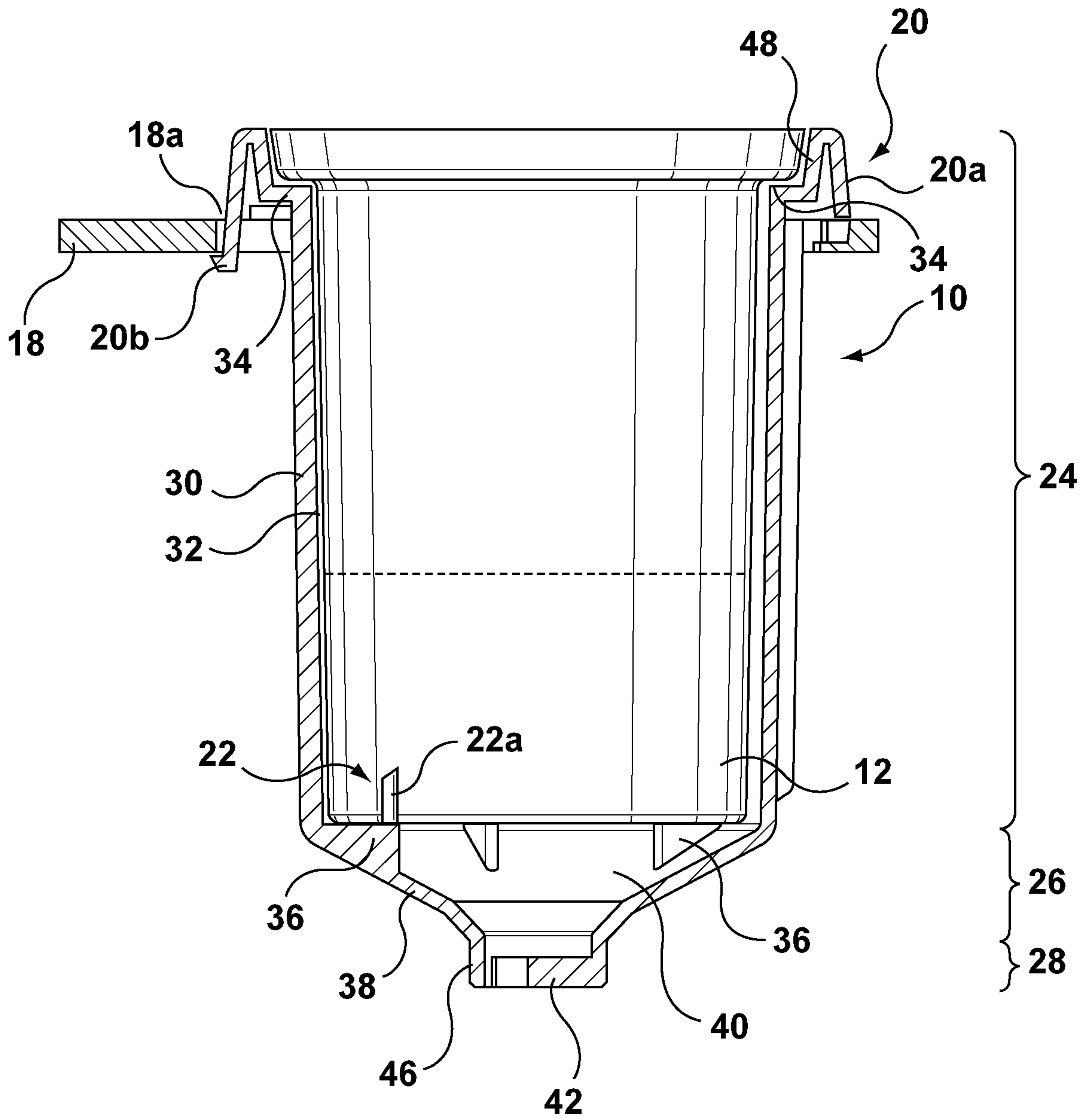

FIG. 3

4/11

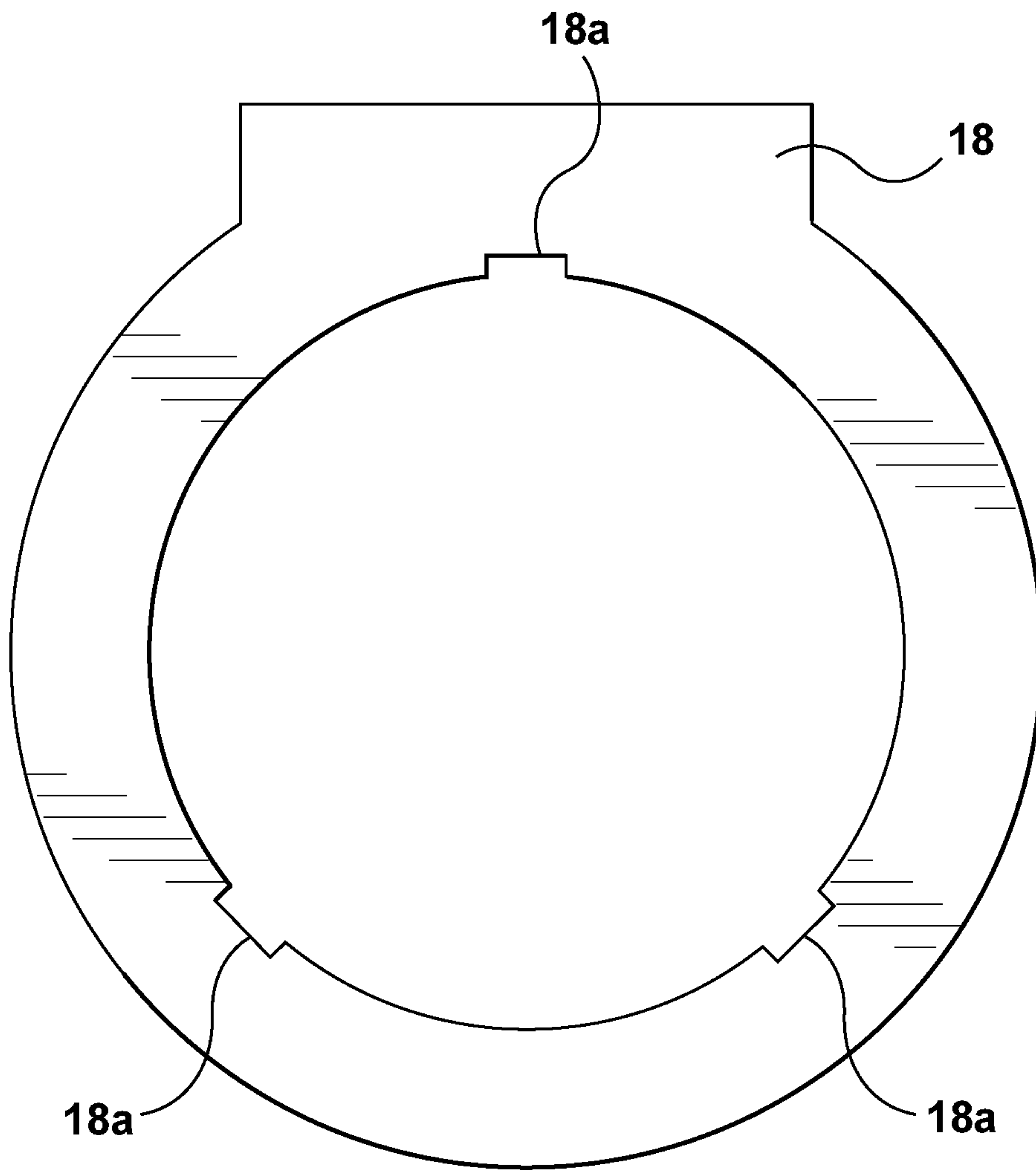

FIG. 4

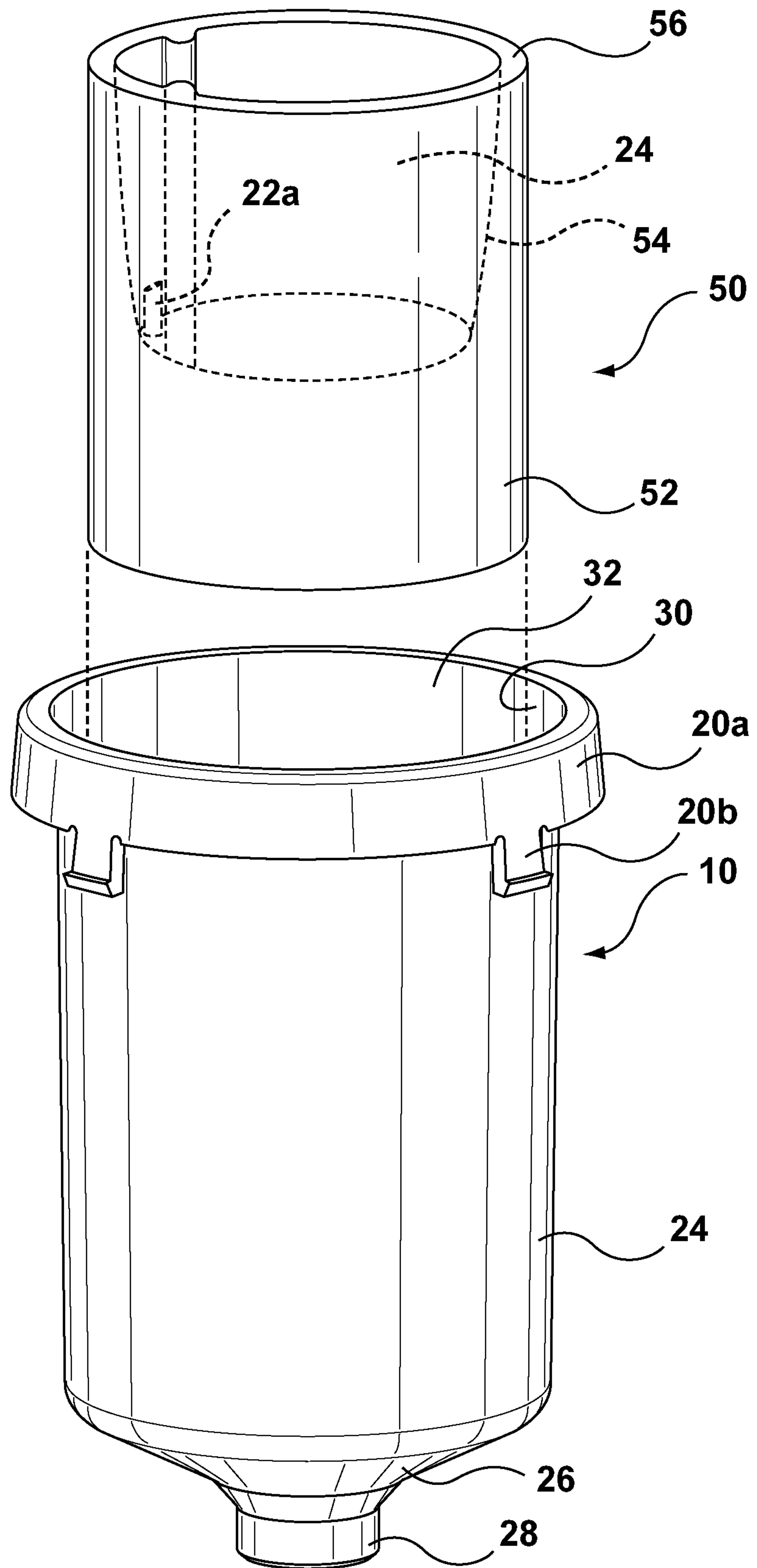

FIG. 5

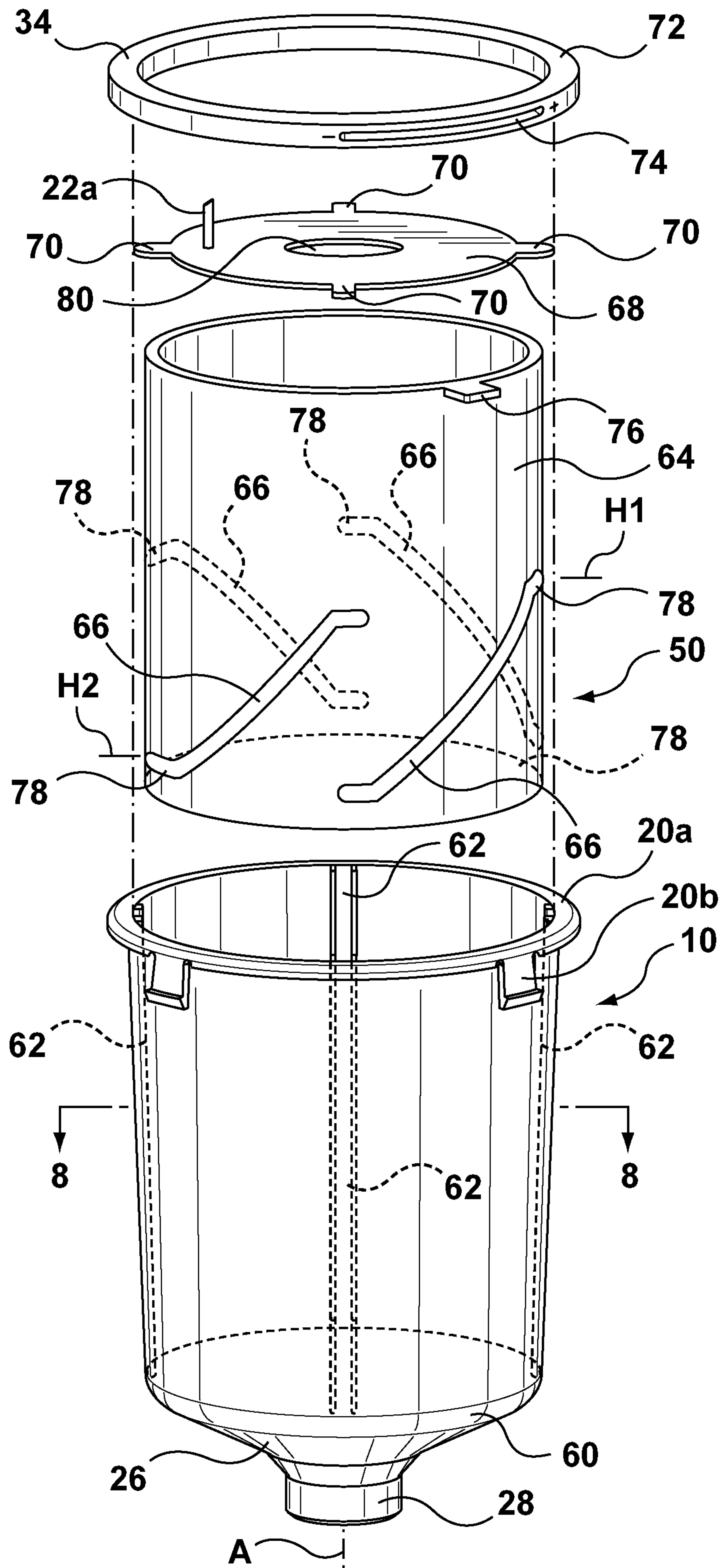

FIG. 7

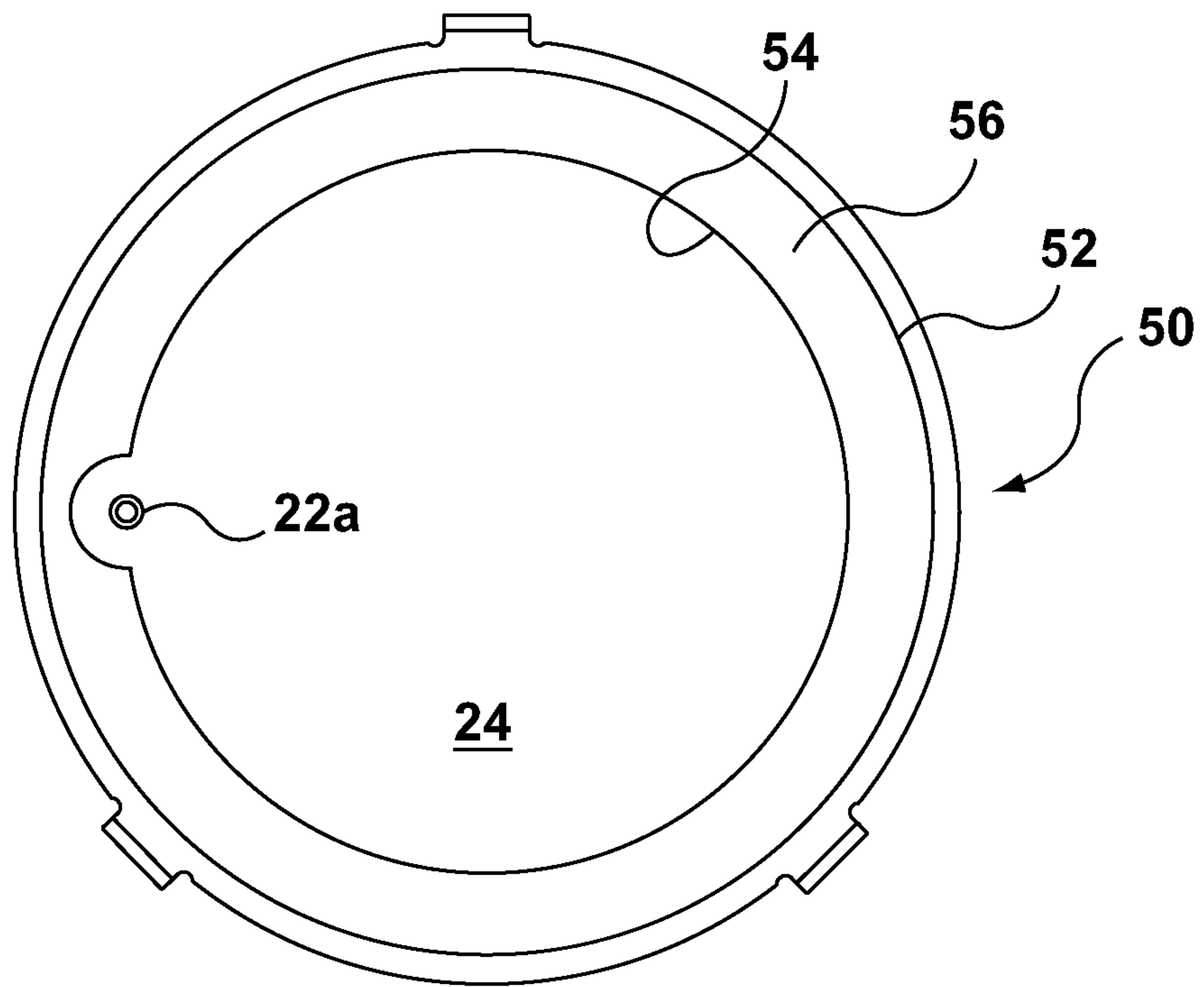

FIG. 6

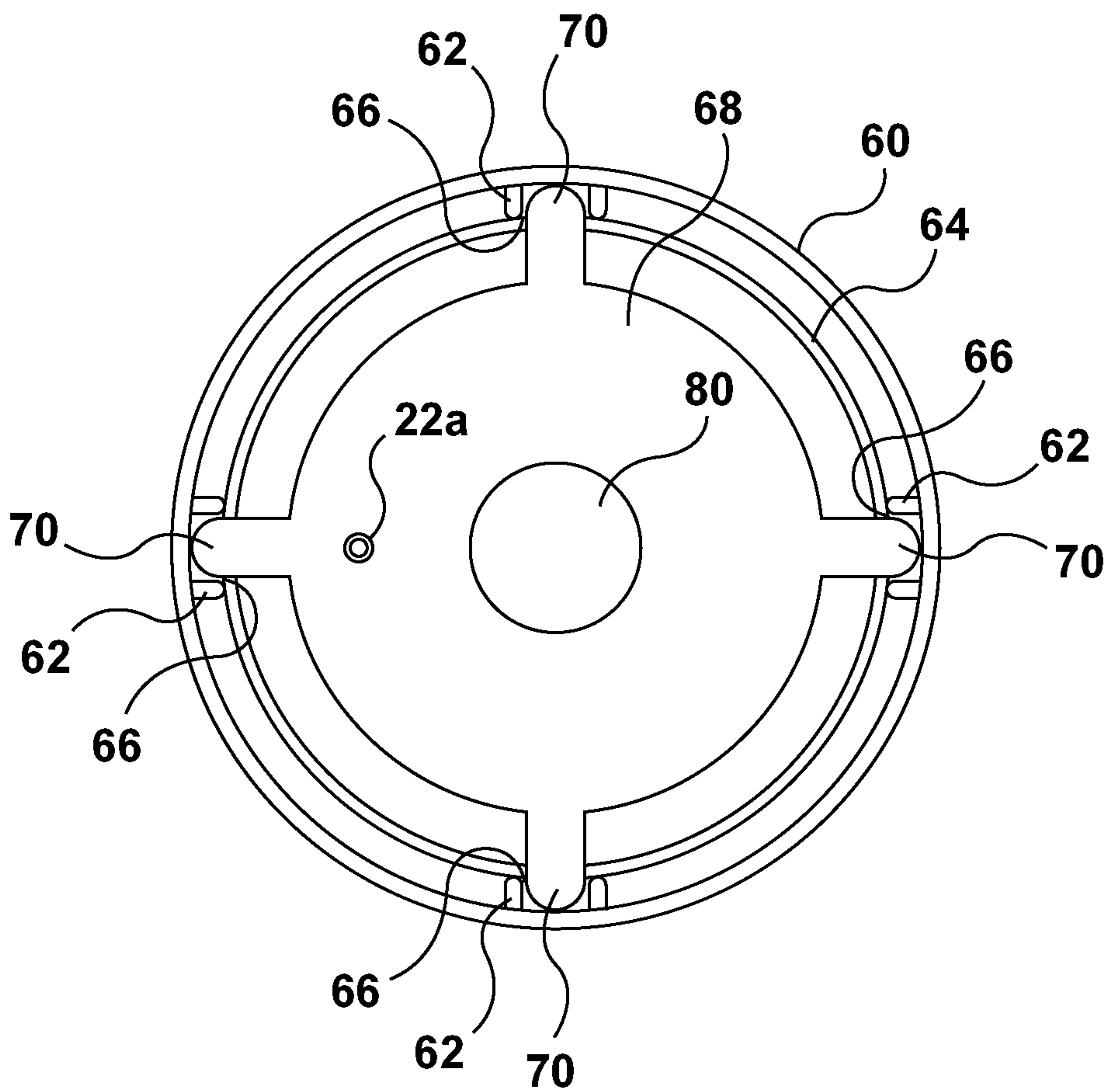

FIG. 8

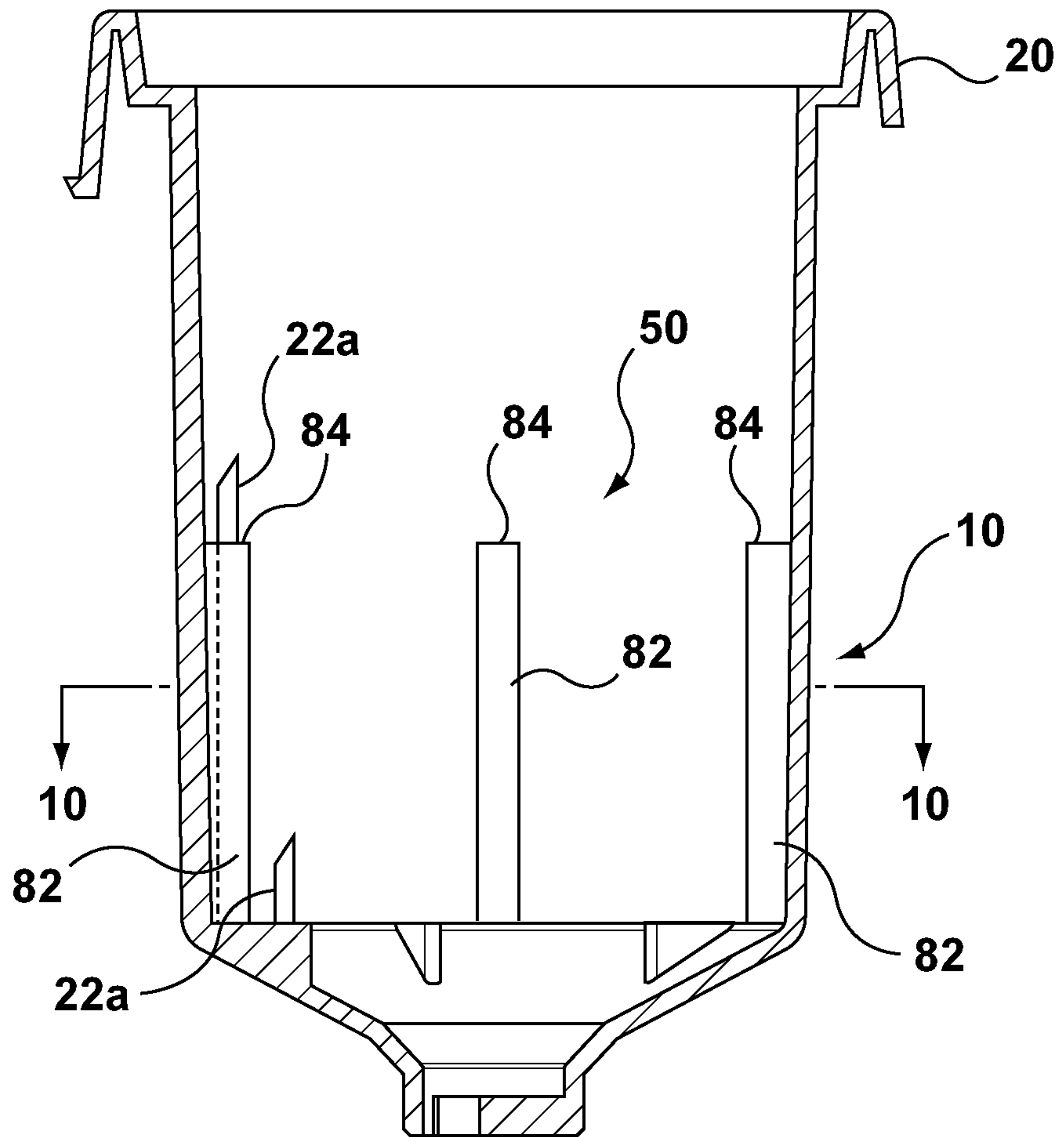

FIG. 9

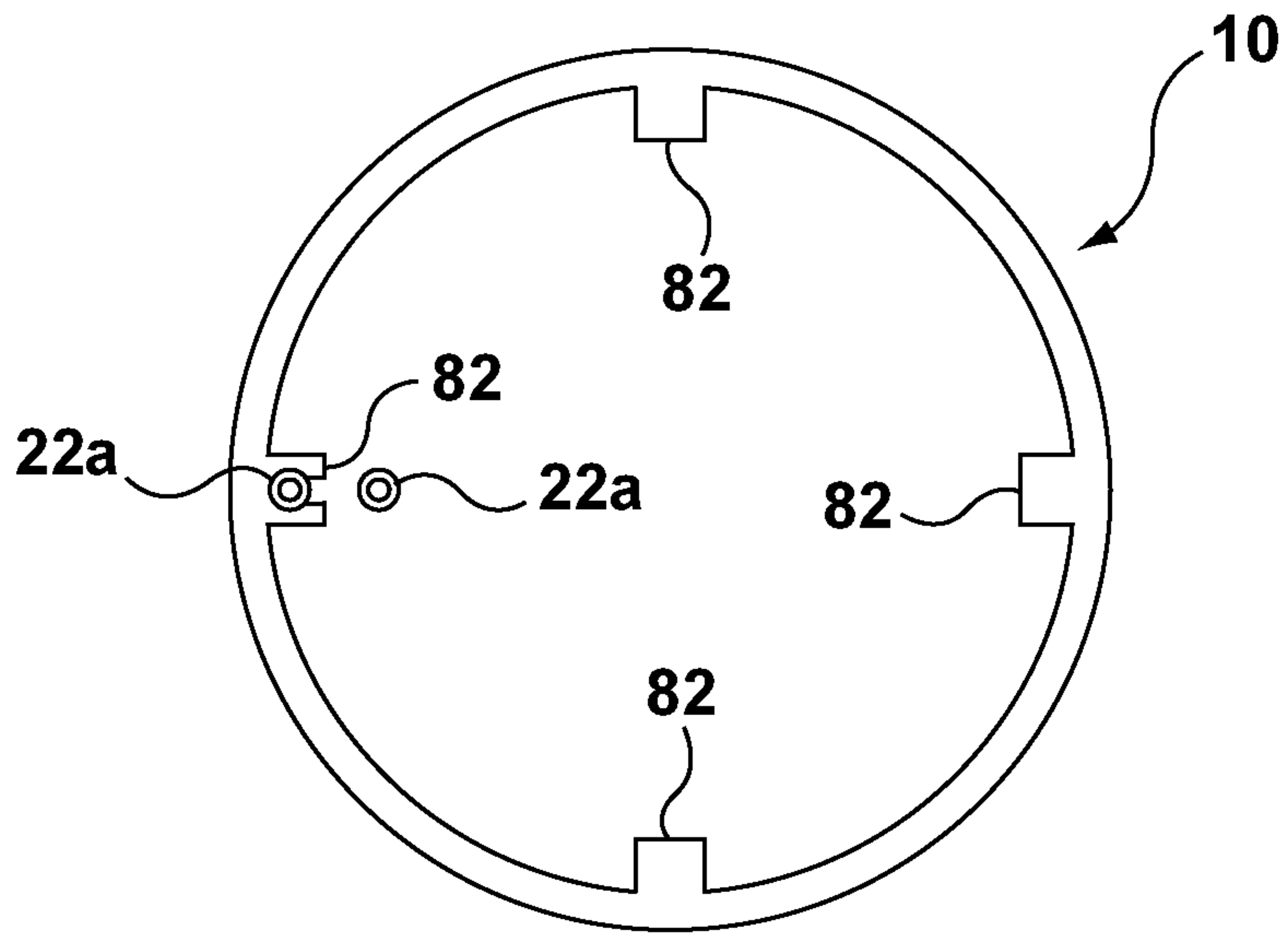

FIG. 10

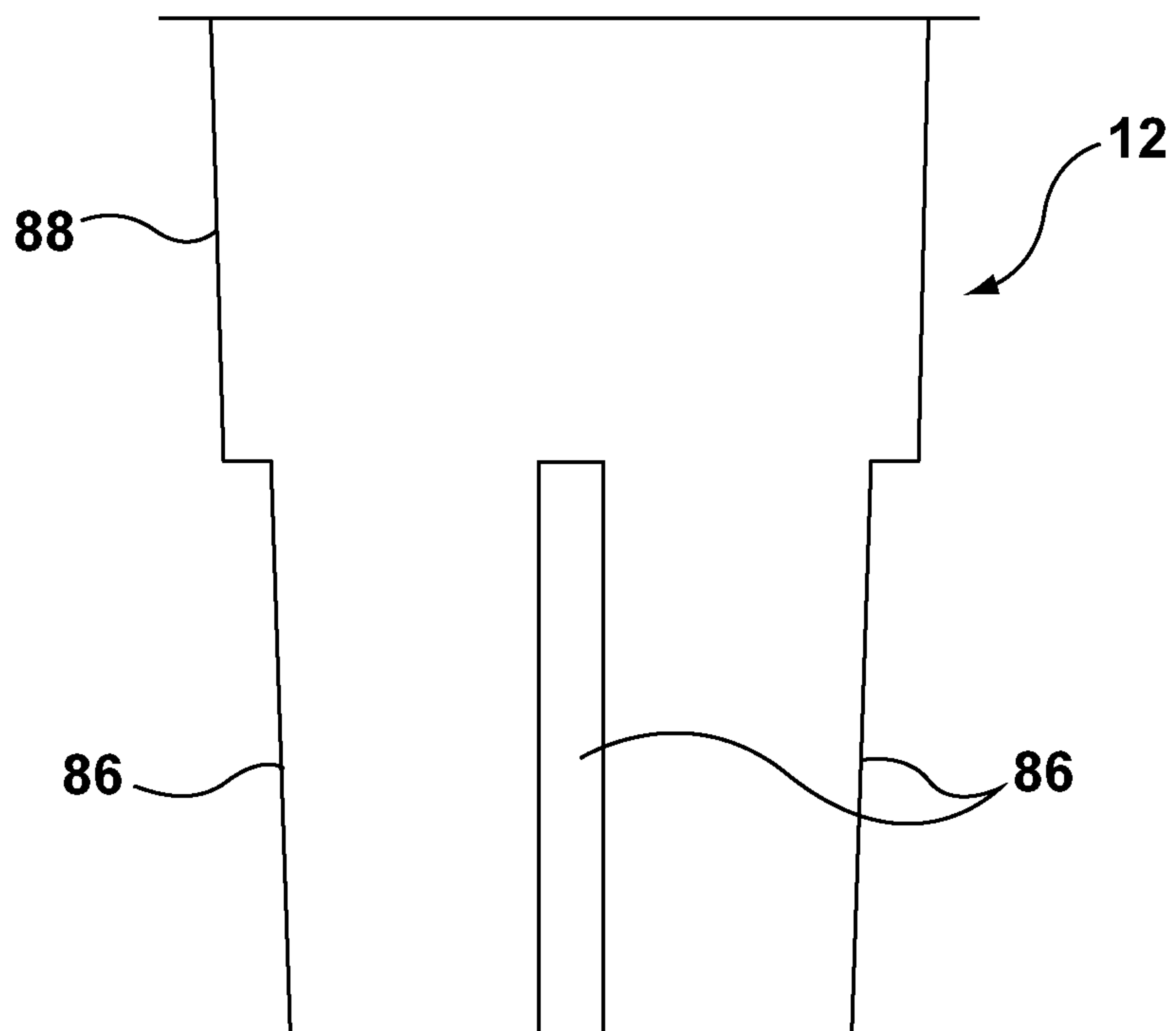

FIG. 11

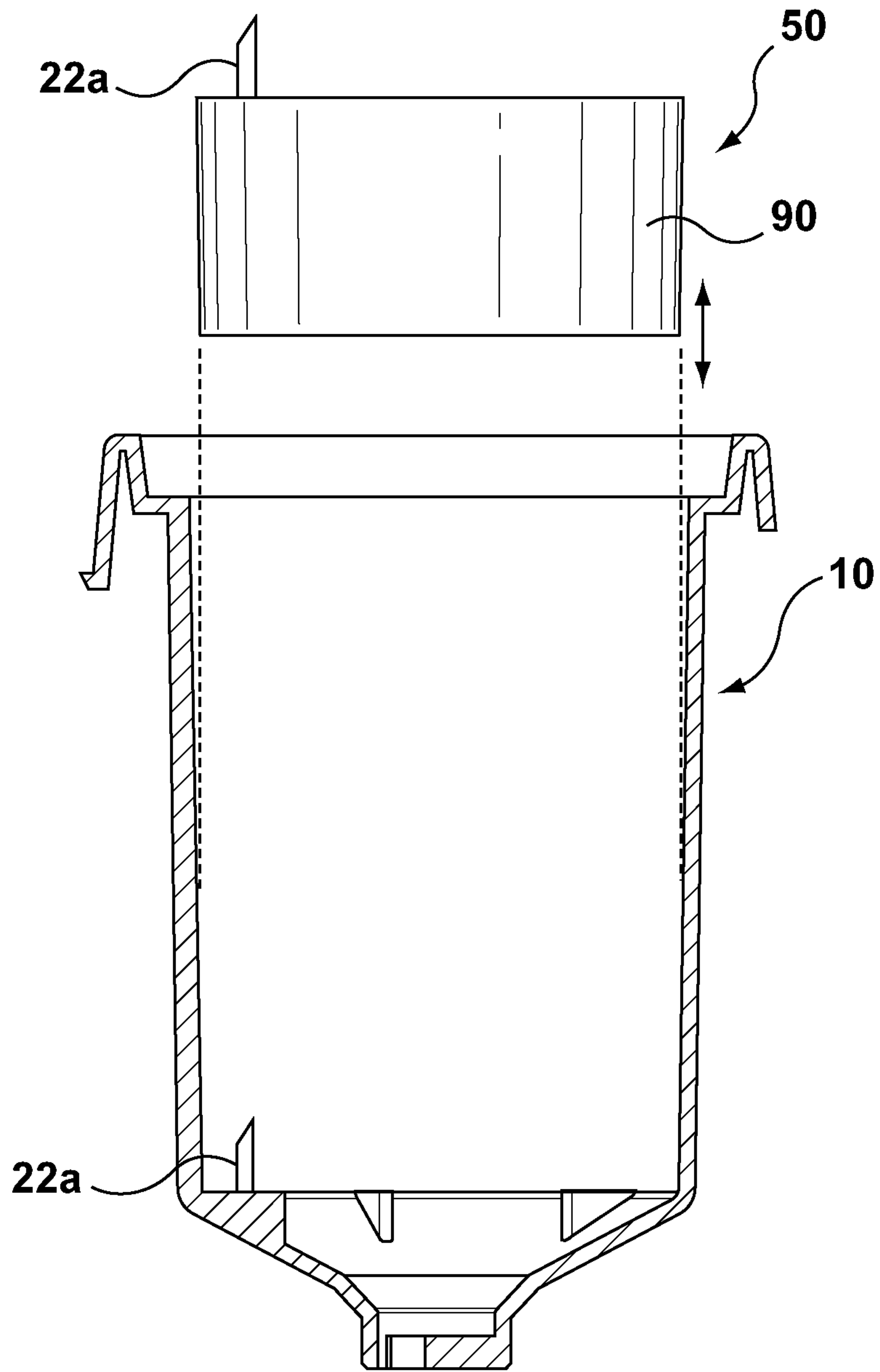

FIG. 12

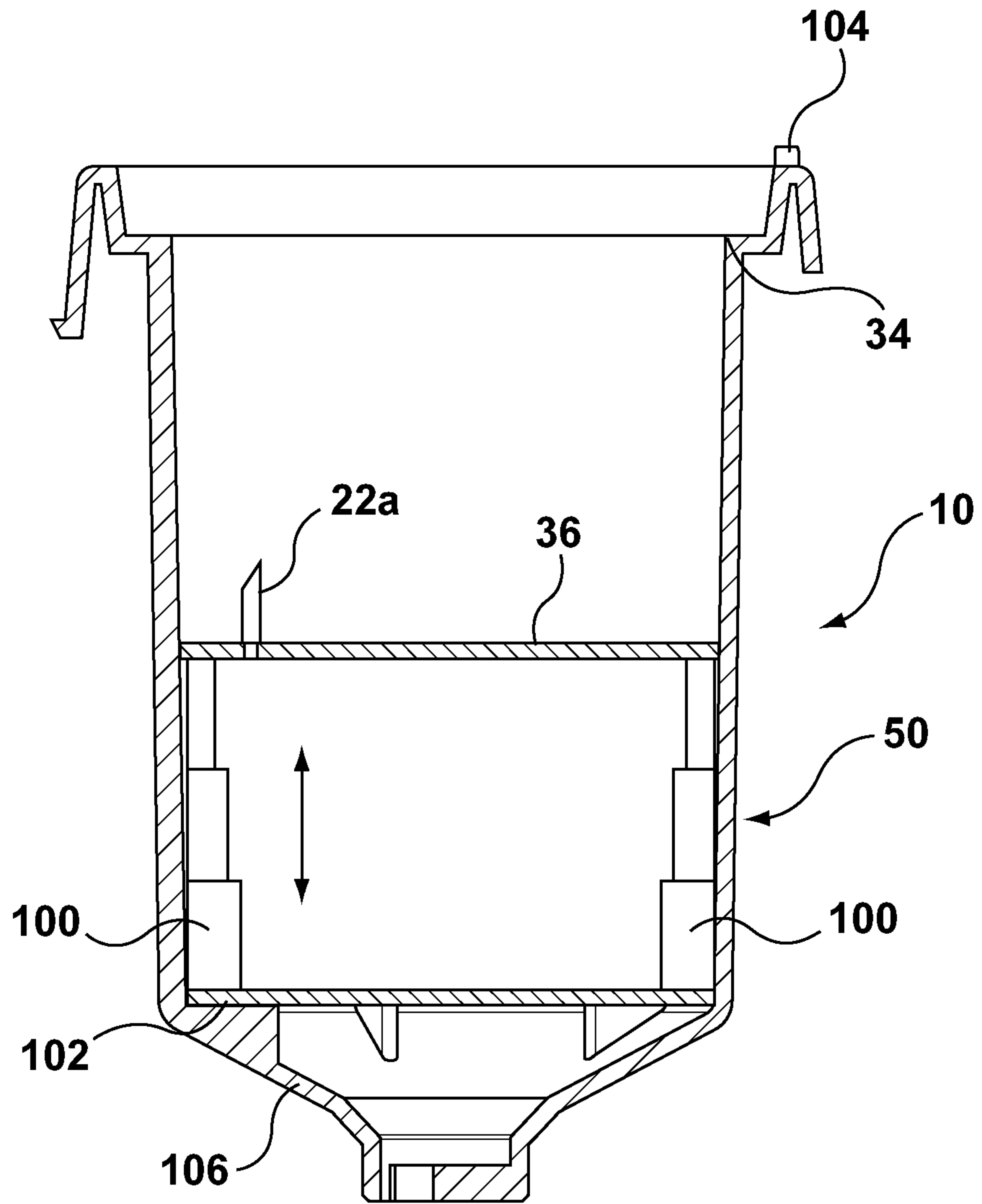

FIG. 13

