

No. 875,573.

PATENTED DEC. 31, 1907.

H. G. FOSTER.

EXTENSION WINDOW SCREEN.

APPLICATION FILED JULY 5, 1904. RENEWED OCT. 17, 1907.

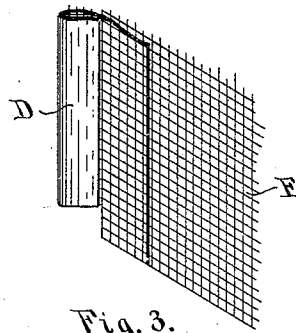
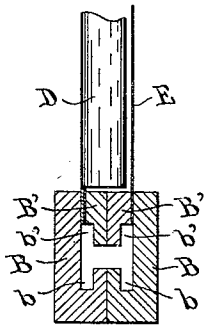
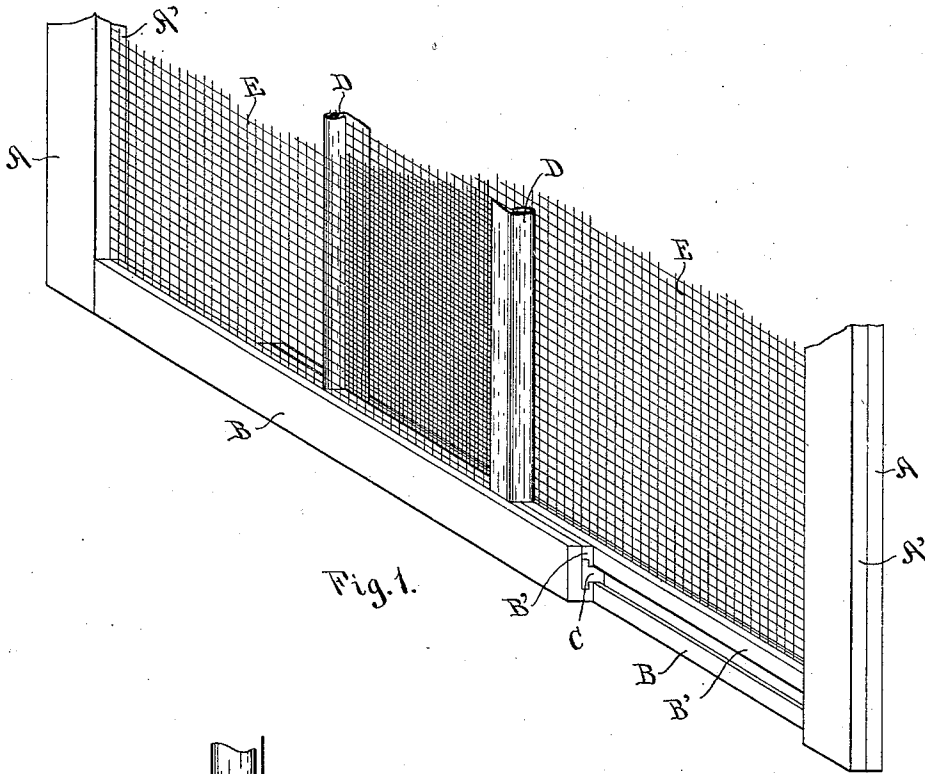

WITNESSES:

*Louis Diven*  
*M. E. Verbeek.*

INVENTOR  
*Henry S. Foster*  
BY  
*Eugene Diven*  
ATTORNEY

# UNITED STATES PATENT OFFICE.

HENRY G. FOSTER, OF HORSEHEADS, NEW YORK, ASSIGNOR, BY MESNE ASSIGNMENTS TO HARRY N. LOW, TRUSTEE, OF WASHINGTON, DISTRICT OF COLUMBIA.

## EXTENSION WINDOW-SCREEN.

No. 875,573.

Specification of Letters Patent.

Patented Dec. 31, 1907.

Application filed July 5, 1904, Serial No. 215,225. Renewed October 17, 1907. Serial No. 397,916.

*To all whom it may concern:*

Be it known that I, HENRY G. FOSTER, a citizen of the United States, residing at Horseheads, in the county of Chemung and State of New York, have invented certain new and useful Improvements in Extension Window-Screens, of which the following is a specification.

My invention relates to improvements in two-part extension screens, in which one-half of the screen slides upon the other, and my object is to provide certain improvements in the manner of constructing the top and bottom rails of the screen sections, and the sliding connections therebetween.

I attain my object by means of the arrangement and construction of the several parts, as illustrated in the accompanying drawings, in which—

Figure 1 represents a perspective view of the lower portion of an extension screen embodying my improvements; Fig. 2, a detail showing a cross section adjacent to one of the metal center bars; and Fig. 3, a detail showing the metal center bar and the manner of securing the netting thereto.

Like letters refer to like parts in the several views.

Each section of the screen is the counterpart of the other; the frames being composed of outer vertical rails A, top and bottom horizontal rails B, and sheet metal center bars D, the latter constituting inner vertical rails for each frame. The frames are connected together by interlocking slide blocks C, fastened at the inner ends of each of the top and bottom rails B, so as to slide in properly formed grooves in the adjacent faces of said rails. This form of interlocking connection between the rails, in itself, is not new, various forms of interlocking blocks and grooves being already in use. The interlocking blocks which I here show by way of illustration are of H-shaped formation, and engage T-shaped grooves formed in the rails B, as shown more particularly in Fig. 2. Heretofore it has been customary to cut these grooves in one piece rails.

My improvement lies in forming a channel or rabbet on each of the adjacent faces of the rails B, and at the same time cutting grooves *b* at the bottom of the rabbet to form one leg of the T-shaped grooves. The edges of the wire netting and the projections formed at the top and bottom of the metal

centers D are fastened to the channeled portions of the rails B near the outer edge, and are covered by strips B' so formed as to fill in the space between the rails left by the channels, and cut so as to complete the interlocking grooves. In the form of construction illustrated these retaining strips B' are formed with rabbets *b'*, which, when the strips are in place on the rails B form the other legs of the T-shaped groove. In the process of manufacture, the saws for forming the channels and grooves in the rails B are so arranged as to cut the retaining strips B' from the same strip of wood, thereby saving time and expense in the process of manufacture. It will be noted that these retaining strips *b'* cover and protect the edges of the netting where they are attached to the rails B, and also give to said rails when they are pulled apart a neat and finished appearance. It will be further noted that the notched ends of the metal center bars D overhang and abut against both of the retaining strips B' on the rails B, whereby the inner edge of the two ends of the bars are made to lie close to the face of the adjacent netting, and to the inner surface of the top and bottom rails. This prevents flies or other insects by any chance from crawling between the netting and the bars, or between the top and bottom rails and the bars. By this arrangement of parts I obtain a rigid and stable connection between the sliding members of the screen in a very simple and cheap manner. The interlocking slide blocks C prevent the top and bottom rails from being separated sidewise or from being pulled apart, and the shoulders on the metal centers D, abutting as they do against both of the adjacent top and bottom rails prevent said rails from being pressed together so as to buckle the screen.

The interlocking slide blocks C and the grooves in the rails B may be given other forms than that illustrated without departing from the spirit of my invention.

Having thus described my improvements, what I claim as my invention and desire to secure by Letters Patent is—

1. In an extensible screen, two frames arranged to overlap and having oppositely disposed channeled portions, the screen fabrics, and sliding connections between the frames including a plurality of coupling members, one carried by each frame and engaging the channeled portion of the opposite frame, in

combination with retaining means in the channeled portions of the frames for the screen fabrics and coupling members.

2. In an extensible screen, two frames arranged to overlap and having oppositely disposed channeled portions, the screen fabrics, and sliding connections between said frames including a plurality of coupling members, one secured against longitudinal movement in the channeled portion of one of the frames and slidably engaging the channeled portion of the opposite frame, in combination with retaining means in the channeled portion of the frames for the coupling members and screen fabrics.

3. In an extensible screen, two frames arranged to overlap and having oppositely disposed channeled portions including grooves in the frames, the screen fabrics, and sliding connections between said frames including a plurality of coupling members, one secured against longitudinal movement in the channeled portion of one of the frames and slidably engaging the groove in the channeled portion of the opposite frame, in combination with retaining means in the channeled portions of the frames for the coupling members and screen fabrics.

4. In an extensible screen, two frames arranged to overlap and having oppositely

channeled portions, the screen fabrics, and sliding connections between the frames including a plurality of coupling members, one carried by each frame and engaging the channeled portion of the opposite frame, in combination with retaining strips fastened in the channeled portions over the screen fabrics and having their inner edges rabbeted to provide slide-ways for the coupling members.

5. An extensible screen comprising two frames arranged to overlap and having oppositely disposed grooved channeled portions, screen fabrics, retaining strips fastened in the channeled portions over the screen fabrics and having their inner edges rabbeted to form, together with the channel grooves, slide-ways of T-shaped cross-section, and sliding connections between the frames including a plurality of coupling members, one carried by each frame and presenting a T shaped projection to engage the slide-way in the opposite frame.

In testimony whereof I have affixed my signature, in presence of two witnesses:

HENRY G. FOSTER.

Witnesses:

GEO. W. ROCKWELL,  
C. L. HATHAWAY.