

(19) World Intellectual Property Organization  
International Bureau



(43) International Publication Date  
9 December 2010 (09.12.2010)

(10) International Publication Number  
**WO 2010/141931 A2**

(51) International Patent Classification:

A47K 10/34 (2006.01) B65H 16/00 (2006.01)  
A47K 10/26 (2006.01)

(21) International Application Number:

PCT/US2010/037561

(22) International Filing Date:

6 June 2010 (06.06.2010)

(25) Filing Language:

English

(26) Publication Language:

English

(30) Priority Data:

61/184,789 6 June 2009 (06.06.2009) US  
61/266,169 3 December 2009 (03.12.2009) US

(71) Applicant (for all designated States except US): **INNOVIA INTELLECTUAL PROPERTIES, LLC** [US/US]; Post Office Box 2526, Matthews, NC 28106-2526 (US).

(72) Inventors; and

(75) Inventors/Applicants (for US only): **TROUTMAN, William, B.** [US/US]; 6247 Glynmoor Lakes, Charlotte, NC 28277-4557 (US). **TROUTMAN, William, B., II** [US/US]; 17823 Meadow Bottom Road, Charlotte, NC 28277-6659 (US). **KOVACEVICH, Ian, D.** [US/US]; 235 Meadowbrook Road, Charlotte, NC 28211-1307 (US). **PHILPOTT, Thomas, James** [GB/US]; 1811 Kensington Drive, Charlotte, NC 28205-3501 (US). **HOY, Christopher** [US/US]; 1711 Harrill Street, Char-

lotte, NC 28205-2850 (US). **OBER, Lawrence** [US/US]; 14544 Limestone Lane, Pineville, NC 28134-8123 (US).

(74) Agents: **TILLMAN, Chad, D.** et al.; Tillman Wright, PLLC, P.O. Box 49309, Charlotte, NC 28277 (US).

(81) Designated States (unless otherwise indicated, for every kind of national protection available): AE, AG, AL, AM, AO, AT, AU, AZ, BA, BB, BG, BH, BR, BW, BY, BZ, CA, CH, CL, CN, CO, CR, CU, CZ, DE, DK, DM, DO, DZ, EC, EE, EG, ES, FI, GB, GD, GE, GH, GM, GT, HN, HR, HU, ID, IL, IN, IS, JP, KE, KG, KM, KN, KP, KR, KZ, LA, LC, LK, LR, LS, LT, LU, LY, MA, MD, ME, MG, MK, MN, MW, MX, MY, MZ, NA, NG, NI, NO, NZ, OM, PE, PG, PH, PL, PT, RO, RS, RU, SC, SD, SE, SG, SK, SL, SM, ST, SV, SY, TH, TJ, TM, TN, TR, TT, TZ, UA, UG, US, UZ, VC, VN, ZA, ZM, ZW.

(84) Designated States (unless otherwise indicated, for every kind of regional protection available): ARIPO (BW, GH, GM, KE, LR, LS, MW, MZ, NA, SD, SL, SZ, TZ, UG, ZM, ZW), Eurasian (AM, AZ, BY, KG, KZ, MD, RU, TJ, TM), European (AL, AT, BE, BG, CH, CY, CZ, DE, DK, EE, ES, FI, FR, GB, GR, HR, HU, IE, IS, IT, LT, LU, LV, MC, MK, MT, NL, NO, PL, PT, RO, SE, SI, SK, SM, TR), OAPI (BF, BJ, CF, CG, CI, CM, GA, GN, GQ, GW, ML, MR, NE, SN, TD, TG).

Published:

— without international search report and to be republished upon receipt of that report (Rule 48.2(g))

(54) Title: AUTOMATIC PAPER TOWEL DISPENSER APPARATUS

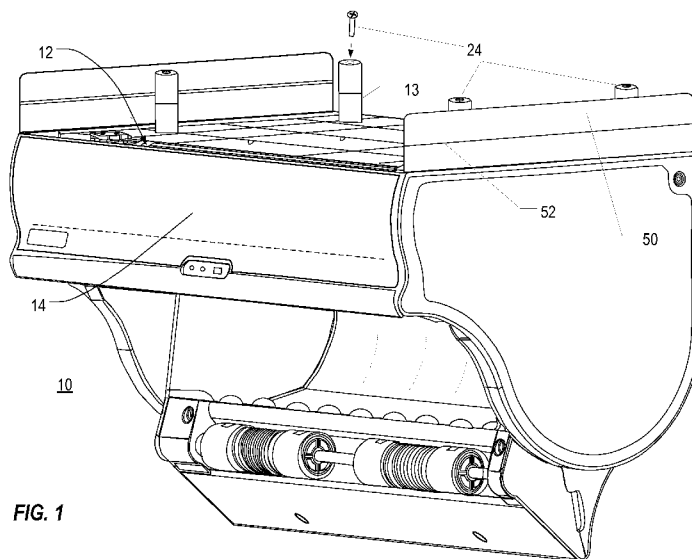

FIG. 1

(57) Abstract: A towel dispenser includes a main body; a loading door receiving toweling in floating engagement therewith; a guide system; a motor assembly; and a sensor for sensing a toweling leading edge. The housing includes an opening permitting retracted toweling to fall there through. The guide system includes a first roller attached to the main body and a second roller attached to the loading door. Toothed surfaces of the rollers mesh when the loading door is moved into a closed position. An end of the first roller moves relative to the main body of the housing such that the first roller is displaced by the second roller and toweling, and the first roller is spring biased in its engagement with the second roller when the loading door is closed. Trim tabs of the housing determine a distance from an underside of a fixture below which the dispenser is mounted.



WO 2010/141931 A2

**AUTOMATIC PAPER TOWEL DISPENSER APPARATUS**

## CROSS-REFERENCE TO RELATED APPLICATION

[001] For purposes of the United States of America, the present application is a U.S. nonprovisional patent application of, and claims priority under 35 U.S.C. §119(e) to each of: Troutman et al. U.S. provisional patent application serial number 61/184,789, filed on June 6, 2009, which is incorporated by reference herein; and Troutman et al. U.S. provisional patent application serial number 61/266,169, filed on December 3, 2009, which is incorporated by reference herein. The present application further incorporates by reference Troutman et al. U.S. patent application publication number 2009/0065628, which published March 12, 2009, titled "*Perforation Sensing Towel Dispenser*".

## COPYRIGHT STATEMENT

[002] All of the material in this patent document is subject to copyright protection under the copyright laws of the United States and other countries. The copyright owner has no objection to the facsimile reproduction by anyone of the patent document or the patent disclosure, as it appears in official governmental records but, otherwise, all other copyright rights whatsoever are reserved.

## BACKGROUND OF THE INVENTION

[003] The present invention generally relates to towel dispensers and, more particularly, to towel dispensers in which a length of toweling is extended from the housing for grasping and pulling by a user for separation and dispensing of one or more towels. In preferred embodiments of the invention, the toweling comprises a roll of perforated towels, in which the towels are connected together and separable at perforation formed between the towels.

[004] Towel dispensers are well known and generally include a housing configured to receive toweling; a guide system that defines a path within the housing and that guides the toweling along the path during movement of the toweling while towels are dispensed; and a motor that moves the toweling along the path to the exterior of the housing, thereby exteriorly extending the toweling from the housing. The guide system can include rollers or fixed guides and typically includes one or more driven rollers connected to the motor. A switch or sensor for detecting motion or proximity of an object is provided to initiate the operation of the motor. For example, in a known dispenser, a controller is electrically connected to the sensor and is configured to activate the motor when the sensor generates a signal that indicates the presence of a hand.

[005] Conventional towel dispensers also generally are configured to dispense towels from continuous rolls of non-perforated toweling and include a device for cutting the toweling to dispense individual towels. The length of the individual towels provided by the dispenser is determined by the amount of time that the motor is operated or by measuring the individual towel as it is dispensed, and

such length generally is preprogrammed into the dispensers such that the same length of toweling is automatically and consistently dispensed each time the hand-motion sensor is activated.

[006] Conventional towel dispensers generally operate as follows. A roll of toweling is placed within the housing and threaded through the guide system. A user causes a towel to be dispensed by placing a hand or other object near the sensor. Alternatively, the dispensing of toweling can be initiated by pressing a button or switch that is configured to activate the motor. Dispensing of the toweling is stopped when a predetermined length of toweling has been dispensed. Alternatively, in some cases the toweling is stopped when the hand is removed or button/switch is released.

[007] Conventional towel dispensers are disclosed in each of U.S. Patent Nos. 6,412,679; 6,419,136; 6,742,689; 6,745,927; 6,766,977; and 7,191,977. Each of these patents is incorporated herein by reference.

[008] Even in view of known towel dispensers, it is believed that one or more needs exist for improved towel dispensers.

#### SUMMARY OF THE INVENTION

[009] The present invention includes many aspects and features. Moreover, while many aspects and features relate to, and are described in, the context of toweling including a roll of sheet material separated by perforations that define towels when separated, the present invention is not limited to use only in such context, and may be used with toweling that does not include such perforations. Moreover, while preferred implementations relate to dispensing of paper towels, the invention is not limited to such implementations and is applicable, for example, in implementations relating to the dispensing of toilet paper or other types of toweling.

[010] Accordingly, in an aspect of the invention, a method of dispensing towels from toweling with a dispenser includes: (a) using a motor assembly configured to cause a leading edge of the toweling to be extended from a housing of the dispenser and to cause the toweling to be subsequently retracted back into the housing, the step of extending the toweling exterior of the housing for grasping by a user; and subsequent thereto, the steps of (b) the step of retracting the toweling into the housing using the motor assembly; the step of sensing a leading edge of the toweling, using a sensor, while retracting the toweling; and the step of ceasing retracting of the toweling into the housing using the motor assembly as a function of sensing the leading edge of the toweling using the sensor. Moreover, it will be understood that reference to a "trailing edge" in the context of sensing an edge of the toweling during retraction is, in fact, the "leading edge" of the toweling extending out of the housing. As such, it will be understood that in this context "trailing edge" and "leading edge" may be synonymous.

[011] In a feature of this aspect, the housing includes a main body and a loading door. The loading door is configured to rotate relative to the main body between a closed position, in which the housing is configured to extend toweling there from, and an open position, in which the housing is configured

to receive toweling therein. Furthermore, the loading door includes a towel carrier having a curved surface defining a cavity within which toweling comprising a roll of paper towels is received and retained in floating engagement therewith. The roll of paper towels rolls and slides on the curved surface when unwinding during said step of extending the toweling exterior of the housing for grasping by a user. Moreover, the toweling gathers within the housing during retracting of the toweling into the housing and does not wind back onto the roll of paper towels. Preferably, the toweling bunches within the housing.

[012] In another feature of the invention, the housing includes a main body, a loading door, and a guide system. The loading door is configured to rotate relative to the main body between a closed position, in which the housing is configured to extend toweling there from, and an open position, in which the housing is configured to receive toweling therein. The guide system is configured to guide the toweling within the housing during extension from and retraction into the housing of the toweling. The guide system includes a first roller attached to the main body and a second roller attached to the loading door. Moreover, the first roller preferably has a toothed surface that is configured to mesh with a toothed surface of the second roller. Furthermore, at least one end of the first roller moves such that an axis of rotation of the first roller moves relative to the main body of the housing. In this feature, the method further includes the step of moving the loading door into the closed position after loading toweling within the dispenser, with the first roller being urged into engagement with the second roller when the loading door enters the closed position and the second roller acting on the first roller so as to displace at least one end of the first roller when the loading door enters the closed position.

[013] In another feature, the housing includes extension walls located proximate opposite exterior sides of the housing that extend above a top side of the housing. In this feature, the method includes a preliminary step of mounting the dispenser to the underside of a fixture, including removing a portion of each extension wall along a score line so as to adjust the distance from the underside of the fixture below which the top side of the housing is mounted. In some embodiments including this feature, but not all such embodiments, the fixture is a cabinet mounted to a wall or suspended from a ceiling. In some embodiments including this feature, but not all such embodiments, the fixture is a shelf that is mounted to a wall.

[014] In another feature of this aspect, the toweling comprises a roll of paper towels and the dispenser is configured to unwind roll of paper towels during extension of toweling from the housing but not rewind the roll of paper towels during subsequent retraction of toweling into the housing. Furthermore, a back side of the housing includes an opening that is configured such that excess toweling gathering within the housing may fall there through as a result of retraction of toweling back into the housing.

[015] In another feature, the toweling comprises towels that are connected together and that are separable at perforations formed there between. In this respect, the toweling preferably comprises a

roll of perforated paper towels. The roll of paper towels generally may be any of those commercially available for consumer purchase, like those from companies such as Proctor & Gamble and Kimberly Clark. With further regard to this feature, the step of extending the toweling exterior of the housing for grasping by the user further preferably includes extending a sufficient length of the toweling such that at least one line of perforations is located outside of the housing whereby tearing along the line of perforations leaves a residual extent of the toweling extending outside of the housing after tearing.

[016] In another feature, the step of extending the toweling exterior of the housing for grasping by the user comprises extending the toweling a predetermined unit length beyond the point at which the sensor detects the leading edge of the toweling. In some embodiments including this feature, but not all such embodiments, this includes extending the toweling an extent that is less than the predetermined unit length such that at least one line of perforations is located outside of the housing, whereby tearing along the line of perforations leaves a residual extent of the toweling extending outside of the housing after tearing; and may even include further extending the toweling another predetermined unit length beyond the point at which the sensor detects the leading edge of the toweling. Furthermore, in at least some embodiments, the step of extending the toweling exterior of the housing for grasping by the user may be performed in response to the sensing of a hand proximate the dispenser.

[017] With regard to this feature, the method in at least some embodiments, but not all, further includes setting the predetermined unit length, by which the toweling is extended, in a length learn sequence. The length learn sequence preferably includes: (i) retracting the toweling until a leading edge of the toweling is sensed by the sensor; (ii) advancing the toweling a preset extended length, the preset extended length being greater than at least a distance between immediately adjacent lines of perforations in the toweling; (iii) retracting the toweling until a leading edge of the toweling is sensed by the sensor while measuring a length by which the toweling is retracted; and (iv) determining the difference between the preset extended length and the measured retracted length, the difference being the predetermined unit length. The preset extended length may be greater than twice the distance between immediately adjacent lines of perforations in the toweling, whereby the predetermined unit length may be set for dispensing up to two towels at a time; may be greater than three times the distance between immediately adjacent lines of perforations in the toweling, whereby the predetermined unit length may be set for dispensing up to three towels at a time; and may be greater than four times the distance between immediately adjacent lines of perforations in the toweling, whereby the predetermined unit length may be set for dispensing up to four towels at a time. The length learn sequence of the dispenser may be initiated by installing a roll of paper towels in the dispenser. This is preferably accomplished by moving a loading door of the dispenser, through which a roll of paper towels is received, to a closed position, with a length of the toweling preferably being draped over and extending from the loading door.

[018] In still another feature of this aspect, the motor assembly includes a motor and a controller that is configured to control operation of the motor and the subsequent extension of the toweling from and retraction of the toweling into the housing. With regard to this feature, the method preferably includes the step of: measuring extension of the toweling from the housing; measuring retraction of the toweling into the housing; or both. In some embodiments including this feature, but not all such embodiments, such measuring is performed using an encoder pinwheel that rotates during extension and retraction of the toweling. In some embodiments including this feature, but not all such embodiments, such measuring is performed using an LED component, complementary metal oxide semiconductor (CMOS) component, and digital signal processor (DSP) component; or a laser component, complementary metal oxide semiconductor (CMOS) component, and digital signal processor (DSP) component. Moreover, the sensor for detecting the leading edge of the toweling may be comprised of the LED component, complementary metal oxide semiconductor (CMOS) component, and digital signal processor (DSP); or may be comprised of the laser component, complementary metal oxide semiconductor (CMOS) component, and digital signal processor (DSP) component.

[019] In another feature, the loading door of the dispenser includes a guiding surface along which toweling rides when retracted into the housing. The guiding surface forms a backdrop that is dark and contrasts well with the toweling so as to better define the leading edge of the toweling for sensing by the sensor.

[020] In another aspect of the invention, a towel dispenser includes: a housing for receiving toweling comprising a roll of paper towels; a motor assembly configured to cause a leading edge of the toweling to be extended from the housing and to cause the toweling to be retracted into the housing after the leading edge has been extended; and a sensor for sensing a leading edge of the toweling during retraction of the toweling by the motor assembly. The sensor is configured to cause the motor assembly to cease retracting the toweling into the housing as a function of the sensing of the leading edge of the toweling during retraction of the toweling into the housing.

[021] In a feature of this aspect, the housing includes a main body and a loading door. The loading door is configured to rotate relative to the main body between a closed position, in which the housing is configured to extend toweling there from, and an open position, in which the housing is configured to receive toweling therein. The loading door comprises a towel carrier having a curved surface defining a cavity configured to receive the roll of paper towels in floating engagement therewith such that the roll of paper towels rolls and slides on the curved surface during unwinding.

[022] In another feature of this aspect, the housing comprises a main body, a loading door, and a guide system. The loading door is configured to rotate relative to the main body between a closed position, in which the housing is configured to extend toweling there from, and an open position, in which the housing is configured to receive toweling therein. The guide system is configured to guide the toweling within the housing during extension from and retraction into the housing of the toweling,

and includes a first roller attached to the main body and having a first toothed surface, and a second roller attached to the loading door and having a second toothed surface that is configured to mesh with the first toothed surface. At least one end of the first roller moves such that an axis of rotation of the first roller moves relative to the main body of the housing. Moreover, the first roller is spring biased toward engagement with the second roller when the loading door is in the closed position, and the toothed surfaces of the first roller and the second roller mesh together when the loading door moves into the closed position from the open position and do not preclude the loading door from moving into the closed position from the open position.

[023] In another feature, the housing further comprises extension walls located proximate opposite exterior sides of the housing that extends above a top side of the housing. Each extension wall includes a weakened line extending parallel to a weakened line of the other extension walls, whereby the extent above the top side at which each extension walls extends may be changed. The extent represents a distance from the underside of a cabinet below which the top side of the housing is mounted when the towel dispenser is installed under a cabinet. In some embodiments including this feature, but not all such embodiments, a back side of the housing includes an opening configured to permit excess toweling to fall during retraction of the toweling back into the housing.

[024] In a feature, the motor assembly comprises a motor and a controller configured to control operation of the motor and the subsequent extension of the toweling from and retraction of the toweling into the housing.

[025] In a feature, the motor assembly is configured to cause a line of perforations of the toweling to be extended from the housing such that whereby tearing along the line of perforations leaves a residual extent of the toweling extending outside of the housing after tearing. In some embodiments including this feature, but not all such embodiments, the motor assembly is further configured to cause the residual extent of the toweling to be retracted into the housing after tearing.

[026] In another feature, the motor assembly is configured to cause the toweling to be extended a predetermined unit length beyond the point at which the sensor detects the leading edge of the toweling. In some embodiments including this feature, but not all such embodiments, the motor assembly is configured to cause the toweling to be further extended an extent that is less than the predetermined unit length in response to the sensing of a hand proximate the dispenser. In some embodiments including this feature, but not all such embodiments, the motor assembly is configured to cause the toweling to be further extended an extent that is less than the predetermined unit length such that at least one line of perforations is located outside of the housing, whereby tearing along the line of perforations leaves a residual extent of the toweling extending outside of the housing after tearing. Furthermore, the motor assembly also may be configured to cause the toweling to be further extended another predetermined unit length beyond the point at which the sensor detects the leading edge of the toweling. The toweling may be further extended another predetermined unit length in response to the continued sensing of the hand proximate the dispenser.

[027] The predetermined unit length, by which the toweling is extended, preferably is set in a length learn sequence. This length learn sequence preferably includes the steps of: (i) retracting the toweling until a leading edge of the toweling is sensed by the sensor; (ii) advancing the toweling a preset extended length, the preset extended length being greater than at least a distance between immediately adjacent lines of perforations in the toweling; (iii) retracting the toweling until a leading edge of the toweling is sensed by the sensor while measuring a length by which the toweling is retracted; and (iv) determining the difference between the preset extended length and the measured retracted length, the difference being the predetermined unit length. The preset extended length may be greater than twice the distance between immediately adjacent lines of perforations in the toweling, whereby the predetermined unit length may be set for dispensing up to two towels at a time; may be greater than three times the distance between immediately adjacent lines of perforations in the toweling, whereby the predetermined unit length may be set for dispensing up to three towels at a time; or may be greater than four times the distance between immediately adjacent lines of perforations in the toweling, whereby the predetermined unit length may be set for dispensing up to four towels at a time. The length learn sequence of the dispenser may be initiated by installing a roll of paper towels in the dispenser. This is preferably accomplished by moving a loading door of the dispenser, through which a roll of paper towels is received, to a closed position, with a length of the toweling preferably being draped over and extending from the loading door.

[028] In still another feature of this aspect, the motor assembly includes a motor and a controller that is configured to control operation of the motor and the subsequent extension of the toweling from and retraction of the toweling into the housing. With regard to this feature, the method preferably includes the step of: measuring extension of the toweling from the housing; measuring retraction of the toweling into the housing; or both. In some embodiments including this feature, but not all such embodiments, such measuring is performed using an encoder pinwheel that rotates during extension and retraction of the toweling. In some embodiments including this feature, but not all such embodiments, such measuring is performed using an LED component, complementary metal oxide semiconductor (CMOS) component, and digital signal processor (DSP) component; or a laser component, complementary metal oxide semiconductor (CMOS) component, and digital signal processor (DSP) component. Moreover, the sensor for detecting the leading edge of the toweling may be comprised of the LED component, complementary metal oxide semiconductor (CMOS) component, and digital signal processor (DSP); or may be comprised of the laser component, complementary metal oxide semiconductor (CMOS) component, and digital signal processor (DSP) component.

[029] In a feature, a loading door of the dispenser comprises a guiding surface along which toweling rides when retracted into the housing, the guiding surface forming a backdrop that is dark and contrasts well with the toweling so as to better define the leading edge of the toweling for sensing by the sensor.

[030] In a feature, the loading door further comprises a guiding surface along which toweling rides when being extended from or retracted into the housing. In some embodiments including this feature, but not all such embodiments, the guiding surface forms a backdrop to the toweling that is dark and contrasts well so as to better define the leading edge of the toweling for sensing by the sensor.

[031] In another feature of this aspect, the towel dispenser includes a sensor for detecting movement of the loading door out of the closed position.

[032] In another aspect, a method of dispensing towels from toweling with a dispenser includes the steps of extending the toweling exterior of the housing for grasping by a user; and subsequent thereto, retracting the toweling into the housing. The housing includes a main body and a loading door that is configured to rotate relative to the main body between a closed position, in which the housing is configured to extend toweling there from, and an open position, in which the housing is configured to receive toweling therein. Furthermore, the loading door comprises a towel carrier that has a curved surface defining a cavity within which toweling comprising a roll of paper towels is received and retained in floating engagement therewith such that the roll of paper towels rolls and slides on the curved surface when unwinding during said step of extending the toweling exterior of the housing for grasping by a user. In some embodiments including this feature, but not all such embodiments, the toweling gathers within the housing during said step of retracting the toweling into the housing, and the toweling is not wound back onto the roll of paper towels.

[033] In another feature of this aspect, the housing further comprises a guide system that is configured to guide the toweling within the housing during extension from and retraction into the housing of the toweling. The guide system comprising a first roller attached to the main body and having a first toothed surface, and a second roller attached to the loading door and having a second toothed surface that is configured to mesh with the first toothed surface. At least one end of the first roller moves such that an axis of rotation of the first roller moves relative to the main body of the housing, and the method further comprises the step of moving the loading door into the closed position after loading toweling within the dispenser, with the first roller being urged into engagement with the second roller when the loading door enters the closed position and the second roller acting on the first roller so as to displace at least one end of the first roller when the loading door enters the closed position. In some embodiments including this feature, but not all such embodiments, the dispenser further comprises a motor assembly configured to cause a leading edge of the toweling to be extended from a housing of the dispenser and to cause the toweling to be subsequently retracted back into the housing, and both of the steps of extending the toweling exterior of the housing for grasping by a user and the step of retracting the toweling into the housing are accomplished using the motor assembly. The method further comprising the steps of sensing a leading edge of the toweling while retracting the toweling into the housing, and ceasing retracting of the toweling into the housing as a function of sensing the leading edge of the toweling.

[034] In a feature, the housing comprises extension walls located proximate opposite exterior sides of the housing that extend above a top side of the housing, and wherein the method further comprises a preliminary step of mounting the dispenser to the underside of a fixture, including removing a portion of each extension wall along a score line so as to adjust the distance from the underside of the fixture below which the top side of the housing is mounted. In some embodiments including this feature, but not all such embodiments, the dispenser further comprises a motor assembly configured to cause a leading edge of the toweling to be extended from a housing of the dispenser and to cause the toweling to be subsequently retracted back into the housing, both of the steps of extending the toweling exterior of the housing for grasping by a user and the step of retracting the toweling into the housing being accomplished using the motor assembly; and the method further comprising the steps of sensing a leading edge of the toweling while retracting the toweling into the housing, and ceasing retracting of the toweling into the housing as a function of sensing the leading edge of the toweling.

[035] In a feature, the toweling comprises a roll of paper towels and the dispenser is configured to unwind roll of paper towels during extension of toweling from the housing but not rewind the roll of paper towels during subsequent retraction of toweling into the housing, and a back side of the housing includes an opening that is configured such that excess toweling gathering within the housing may fall as a result of retraction of toweling back into the housing. In some embodiments including this feature, but not all such embodiments, the dispenser further comprises a motor assembly configured to cause a leading edge of the toweling to be extended from a housing of the dispenser and to cause the toweling to be subsequently retracted back into the housing, and both of the steps of extending the toweling exterior of the housing for grasping by a user and the step of retracting the toweling into the housing are accomplished using the motor assembly; and the method further comprising the steps of sensing a leading edge of the toweling while retracting the toweling into the housing, and ceasing retracting of the toweling into the housing as a function of sensing the leading edge of the toweling.

[036] In another aspect, a towel dispenser includes: a housing for receiving toweling and a guide system that is configured to guide the toweling within the housing while towels are dispensed from the housing. The housing includes a main body and a loading door that is configured to rotate relative to the main body between a closed position, in which the housing is configured to dispense towels there from, and an open position, in which the housing is configured to receive toweling therein. Furthermore, the loading door comprises a towel carrier having a curved surface defining a cavity configured to receive the roll of paper towels in floating engagement therewith such that the roll of paper towels rolls and slides on the curved surface during unwinding. In some embodiments including this feature, but not all such embodiments, the housing further comprises a guide system that is configured to guide the toweling within the housing during extension from and retraction into the housing of the toweling. The guide system comprises a first roller attached to the main body and having a first toothed surface, and a second roller attached to the loading door and having a second toothed surface that is configured to mesh with the first toothed surface. At least one end of the first

roller moves such that an axis of rotation of the first roller moves relative to the main body of the housing, and the first roller is spring biased toward engagement with the second roller when the loading door is in the closed position. Moreover, the toothed surfaces of the first roller and the second roller mesh together when the loading door moves into the closed position from the open position and do not preclude the loading door from moving into the closed position from the open position. Also, in some of these embodiments, the housing further comprises a motor assembly and a sensor. The motor assembly is configured to cause a leading edge of the toweling to be extended from the housing and to cause the toweling to be retracted into the housing after the leading edge has been extended. The sensor senses a leading edge of the toweling during retraction of the toweling by the motor assembly, and the sensor is configured to cause the motor assembly to cease retracting the toweling into the housing as a function of the sensing of the leading edge of the toweling during retraction of the toweling into the housing.

[037] In another feature of this aspect, the housing further comprises extension walls located proximate opposite exterior sides of the housing that extends above a top side of the housing, each extension wall comprising a weakened line extending parallel to a weakened line of the other extension walls, whereby the extent above the top side at which each extension walls extends may be changed, the extent representing a distance from the underside of a fixture below which the top side of the housing is mounted when the towel dispenser is installed under the fixture. In some embodiments including this feature including this feature, but not all such embodiments, the housing further comprises a motor assembly and a sensor. The motor assembly is configured to cause a leading edge of the toweling to be extended from the housing and to cause the toweling to be retracted into the housing after the leading edge has been extended. The sensor senses a leading edge of the toweling during retraction of the toweling by the motor assembly, and the sensor is configured to cause the motor assembly to cease retracting the toweling into the housing as a function of the sensing of the leading edge of the toweling during retraction of the toweling into the housing.

[038] In another feature, a back side of the housing includes an opening configured to permit excess toweling to fall during retraction of the toweling back into the housing. In some embodiments including this feature, but not all such embodiments, the housing further comprises a motor assembly and a sensor. The motor assembly is configured to cause a leading edge of the toweling to be extended from the housing and to cause the toweling to be retracted into the housing after the leading edge has been extended. The sensor senses a leading edge of the toweling during retraction of the toweling by the motor assembly, and the sensor is configured to cause the motor assembly to cease retracting the toweling into the housing as a function of the sensing of the leading edge of the toweling during retraction of the toweling into the housing.

[039] In still another feature of this aspect, the guide system comprises a first roller attached to the main body and a second roller attached to the loading door. In some embodiments including this feature, but not all such embodiments, the second roller is the only roller of the guide system affixed

to the loading door. In some embodiments including this feature, but not all such embodiments, the second roller comprises a lower drive roller of the guide system, and the first roller comprises an upper drive roller of the guide system, the lower drive roller engaging the upper drive roller with toweling extending there between when the loading door is moved into the closed position with toweling draped over the loading door. Also, in some embodiments including this feature, but not all such embodiments, the loading door has a second curved surface that defines a second cavity within which the second roller is retained. Additionally, the loading door may include a first component, a surface of which comprises the curved surface defining the cavity within which the roll of paper towels is received and retained, and a second component, a surface of which comprises the second curved surface defining the second cavity within which the second roller is retained, wherein the second component is affixed to the first component. Furthermore, in this regard, the second component may further define a guiding surface along which toweling rides when extended from the housing.

[040] In another feature of this aspect, the towel dispenser further comprises a sensor that is mounted to the main body and configured to sense a leading edge of the toweling between a gap formed by the main body and the loading door when the loading door is in the closed position. In some embodiments incorporating this feature, but not all such embodiments, the loading door comprises a guiding surface that provides a backdrop to toweling, the sensor sensing the leading edge of the toweling against the backdrop of the guiding surface of the loading door. The sensor may comprise a sensor array. Also, In some embodiments incorporating this feature, but not all such embodiments, the guide system comprises a first roller attached to the main body and a second roller attached to the loading door. The second roller may be the only roller of the guide system on the loading door; the loading door may have a second curved surface defining a second cavity within which the second roller is received and retained; and the loading door may comprise a first component, a surface of which comprises the curved surface defining the cavity within which the roll of paper towels is received and retained, and a second component affixed to the first component, a surface of the second component comprising the second curved surface defining the second cavity within which the second roller is received and retained. The second component also further may define a guiding surface against which toweling rides when extended from the housing.

[041] In another aspect of the invention, a method of dispensing towels from toweling with a dispenser includes the steps of extending the toweling exterior of the housing for grasping by a user; and subsequent thereto, retracting the toweling into the housing. In this regard, the housing comprises a main body, a loading door, and a guide system. The loading door is configured to rotate relative to the main body between closed position, in which the housing is configured to extend toweling there from, and an open position, in which the housing is configured to receive toweling therein. The guide system is configured to guide the toweling within the housing during extension from and retraction into the housing of the toweling, and comprises a first roller attached to the main body and having a

first toothed surface, and a second roller attached to the loading door and having a second toothed surface that is configured to mesh with the first toothed surface. At least one end of the first roller moves such that an axis of rotation of the first roller moves relative to the main body of the housing. The method further includes the step of moving the loading door into the closed position after loading toweling within the dispenser, with the first roller being urged into engagement with the second roller when the loading door enters the closed position and the second roller acting on the first roller so as to displace at least one end of the first roller when the loading door enters the closed position.

[042] In a feature of this aspect, the housing comprises extension walls located proximate opposite exterior sides of the housing that extend above a top side of the housing, and the method further comprises a preliminary step of mounting the dispenser to the underside of a fixture, including removing a portion of each extension wall along a score line so as to adjust the distance from the underside of the fixture below which the top side of the housing is mounted. In some embodiments incorporating this feature, but not all such embodiments, the dispenser further comprises a motor assembly configured to cause a leading edge of the toweling to be extended from a housing of the dispenser and to cause the toweling to be subsequently retracted back into the housing, both of the steps of extending the toweling exterior of the housing for grasping by a user and the step of retracting the toweling into the housing being accomplished using the motor assembly; and the method further comprises the steps of sensing a leading edge of the toweling while retracting the toweling into the housing, and ceasing retracting of the toweling into the housing as a function of sensing the leading edge of the toweling. Also, In some embodiments incorporating this feature, but not all such embodiments, the loading door comprises a towel carrier having a curved surface defining a cavity within which toweling comprising a roll of paper towels is received and retained in floating engagement therewith, the roll of paper towels rolling and sliding on the curved surface when unwinding during said step of extending the toweling exterior of the housing for grasping by a user, and toweling gathering within the housing during retracting of the toweling into the housing and not being wound back onto the roll of paper towels.

[043] In a feature of this aspect, the toweling comprises a roll of paper towels and the dispenser is configured to unwind roll of paper towels during extension of toweling from the housing but not rewind the roll of paper towels during subsequent retraction of toweling into the housing. Furthermore, a back side of the housing includes an opening that is configured such that excess toweling gathering within the housing may fall there through as a result of retraction of toweling back into the housing. In some embodiments incorporating this feature, but not all such embodiments, the dispenser further comprises a motor assembly configured to cause a leading edge of the toweling to be extended from a housing of the dispenser and to cause the toweling to be subsequently retracted back into the housing, both of the steps of extending the toweling exterior of the housing for grasping by a user and the step of retracting the toweling into the housing being accomplished using the motor assembly; and the method further comprises the steps of sensing a leading edge of the toweling while

retracting the toweling into the housing, and ceasing retracting of the toweling into the housing as a function of sensing the leading edge of the toweling. Also, In some embodiments incorporating this feature, but not all such embodiments, the loading door comprises a towel carrier having a curved surface defining a cavity within which toweling comprising a roll of paper towels is received and retained in floating engagement therewith, the roll of paper towels rolling and sliding on the curved surface when unwinding during said step of extending the toweling exterior of the housing for grasping by a user, and toweling gathering within the housing during retracting of the toweling into the housing and not being wound back onto the roll of paper towels.

[044] In another aspect, a towel dispenser comprises a housing for receiving toweling. The housing includes a main body, a loading door, and a guide system. The loading door is configured to rotate relative to the main body between a closed position, in which the housing is configured to dispense towels there from, and an open position, in which the housing is configured to receive toweling therein. The guide system is configured to guide the toweling within the housing while towels are dispensed from the housing. Furthermore, the guide system comprises a first roller attached to the main body and having a first toothed surface, and a second roller attached to the loading door and having a second toothed surface that is configured to mesh with the first toothed surface. The toothed surfaces of the first roller and the second roller mesh together when the loading door moves into the closed position from the open position and do not preclude the loading door from moving into the closed position from the open position. In a feature of this aspect, the housing further comprises extension walls located proximate opposite exterior sides of the housing that extends above a top side of the housing, each extension wall comprising a weakened line extending parallel to a weakened line of the other extension walls, whereby the extent above the top side at which each extension walls extends may be changed, the extent representing a distance from the underside of a fixture below which the top side of the housing is mounted when the towel dispenser is installed under the fixture. In some embodiments incorporating this feature, but not all such embodiments, the housing further comprises a motor assembly configured to cause a leading edge of the toweling to be extended from the housing and to cause the toweling to be retracted into the housing after the leading edge has been extended, and a sensor for sensing a leading edge of the toweling during retraction of the toweling by the motor assembly. The sensor is configured to cause the motor assembly to cease retracting the toweling into the housing as a function of the sensing of the leading edge of the toweling during retraction of the toweling into the housing. Also, In some embodiments incorporating this feature, but not all such embodiments, the loading door comprises a towel carrier having a curved surface defining a cavity configured to receive the roll of paper towels in floating engagement therewith such that the roll of paper towels rolls and slides on the curved surface during unwinding.

[045] In another feature of this aspect, a back side of the housing includes an opening configured to permit excess toweling to fall during retraction of the toweling back into the housing. In some embodiments incorporating this feature, but not all such embodiments, the housing further comprises

a motor assembly configured to cause a leading edge of the toweling to be extended from the housing and to cause the toweling to be retracted into the housing after the leading edge has been extended, and a sensor for sensing a leading edge of the toweling during retraction of the toweling by the motor assembly, wherein the sensor is configured to cause the motor assembly to cease retracting the toweling into the housing as a function of the sensing of the leading edge of the toweling during retraction of the toweling into the housing. In some embodiments incorporating this feature, but not all such embodiments, the loading door comprises a towel carrier having a curved surface defining a cavity configured to receive the roll of paper towels in floating engagement therewith such that the roll of paper towels rolls and slides on the curved surface during unwinding.

[046] In a feature of this aspect, each toothed surfaces has a fairly large and forgiving tooth geometry.

[047] In another feature, the first roller engages the second roller when the loading door is in the closed position.

[048] In a feature, an axis of rotation of the first roller is located above and forward of an axis of rotation of the second roller when the loading door is in the closed position.

[049] In a feature, the first roller extends generally alongside a compartment of the housing in which a battery is received, the compartment being accessible through a removable front cover of the housing for changing the battery.

[050] In a feature, each toothed surface comprises an axially mounted end gear.

[051] In a feature, the first toothed surfaces is located proximate a first end of the first roller, and wherein the second toothed surface is located proximate a first end of the second roller, the respective first ends of the first and second rollers being located proximate one another when the loading door is in the closed position.

[052] In a feature, a transmission connects a motor to a second end of the first roller, the second end of the first roller being opposite to the first end of the first roller. In some various embodiments incorporating this feature, but not all such embodiments, the first end of the first roller is configured to move vertically a small extent, but the second end of the first roller is not configured to move vertically a small extent; the toothed surface of the first roller is spring biased into meshing engagement with the toothed surface of the second roller when the loading door moves into the closed position from the open position; and the second end of the first roller comprises a pivot point of the first roller. Also, in some embodiments incorporating this feature, but not all such embodiments, the first end of the first roller floats relative to the main body, but the second end of the first roller is fixed relative to the main body. In this respect, the toothed surface of the first roller may be spring biased into meshing engagement with the toothed surface of the second roller when the loading door moves into the closed position from the open position, and the second end of the first roller may comprise a pivot point of the first roller.

[053] In a feature, a belt engages the second end of the first roller for driving of the first roller by the motor.

[054] In a feature, the toothed surface of the first roller is spring biased into meshing engagement with the toothed surface of the second roller when the loading door moves into the closed position from the open position.

[055] In still another feature, the only rollers of the guide system are the first and second rollers.

[056] In another aspect of the invention, a towel dispenser comprises a housing for receiving toweling. The housing comprises a main body, a loading door, and a guide system. The loading door is configured to rotate relative to the main body between a closed position, in which the housing is configured to dispense towels there from, and an open position, in which the housing is configured to receive toweling therein. The guide system is configured to guide the toweling within the housing while towels are dispensed from the housing and comprises a first roller attached to the main body and having a toothed surface proximate a first end thereof, and a second roller attached to the loading door and having a toothed surface proximate a first end thereof that is configured to mesh with the toothed surface of the first roller. The housing further comprises a transmission that connects a motor to a second end of the first roller, the second end of the first roller being opposite the first end of the first roller.

[057] In a feature of this aspect, the motor is located within the main body between the first roller and a front panel of the housing.

[058] In a feature of this aspect, the housing further comprises a battery compartment and wherein the motor is battery powered, the battery compartment and motor being located within the main body between the first roller and a front panel of the housing.

[059] In a feature of this aspect, the first end of the first roller is configured to move vertically by a small extent, but the second end of the first roller is not configured to move vertically by a small extent. In various embodiments incorporating this feature, but not all such embodiments, the toothed surface of the first roller is spring biased into meshing engagement with the toothed surface of the second roller when the loading door is in the closed position; and the second end of the first roller comprises a pivot point of the first roller.

[060] In a feature of this aspect, the first end of the first roller floats relative to the main body, but the second end of the first roller is fixed relative to the main body.

[061] In a feature of this aspect, the toothed surface of the first roller is spring biased into meshing engagement with the toothed surface of the second roller when the loading door moves into the closed position from the open position. In various embodiments incorporating this feature, but not all such embodiments, the second end of the first roller comprises a pivot point of the first roller.

[062] In a feature of this aspect, a belt engages the first roller proximate a second end thereof for driving of the first roller by the motor.

[063] In a feature of this aspect, the toothed surface of the first roller is spring biased into meshing engagement with the toothed surface of the second roller when the loading door is in the closed position.

[064] In a feature of this aspect, the only rollers of the guide system are the first and second rollers.

[065] In still another aspect, a towel dispenser includes a housing for receiving toweling. The housing comprises a main body, a loading door, and a guide system. The loading door that is configured to rotate relative to the main body between a closed position, in which the housing is configured to dispense towels there from, and an open position, in which the housing is configured to receive toweling therein. The guide system is configured to guide the toweling within the housing while towels are dispensed from the housing, and includes a first roller attached to the main body and having a first toothed surface, and a second roller attached to the loading door and having a second toothed surface that is configured to mesh with the first toothed surface. The first roller is spring biased toward engagement with the second roller when the loading door is in the closed position.

[066] In a feature of this aspect, a transmission connects a motor to a second end of the first roller, the second end of the first roller being opposite to the first end of the first roller. In some embodiments incorporating this feature, but not all such embodiments, the first end of the first roller is configured to move vertically a small extent, but the second end of the first roller is not configured to move vertically a small extent. Additionally, in various ones of such embodiments, the second end of the first roller comprises a pivot point of the first roller; the first end of the first roller floats relative to the main body, but the second end of the first roller is fixed relative to the main body; and the second end of the first roller comprises a pivot point of the first roller.

[067] In a feature of this aspect, a belt engages the second end of the first roller for driving of the first roller by the motor.

[068] In another feature of this aspect, the only rollers of the guide system are the first and second rollers.

[069] In yet another feature of this aspect, the second roller acts against the spring biasing of the first roller to displace at least one end of the first roller when the loading door is moved into the closed position.

[070] In an aspect of the invention, a method of dispensing towels from toweling with a dispenser includes the steps of: extending the toweling exterior of a housing of the dispenser for grasping by a user; and subsequent thereto, retracting the toweling into the housing. The housing comprises extension walls located proximate opposite exterior sides of the housing that extend above a top side of the housing, and the method further comprises a preliminary step of mounting the dispenser to the underside of a fixture, including removing a portion of each extension wall along a score line so as to adjust the distance from the underside of the fixture below which the top side of the housing is mounted.

[071] In a feature of this aspect, the toweling comprises a roll of paper towels and the dispenser is configured to unwind roll of paper towels during extension of toweling from the housing but not rewind the roll of paper towels during subsequent retraction of toweling into the housing, and a back side of the housing includes an opening that is configured such that excess toweling gathering within the housing may fall as a result of retraction of toweling back into the housing. In embodiments that incorporate this feature, but not all such embodiments, the method further comprises the steps of: using a motor assembly configured to cause a leading edge of the toweling to be extended from a housing of the dispenser and to cause the toweling to be subsequently retracted back into the housing in said steps of the method; sensing a leading edge of the toweling while retracting the toweling; and ceasing retracting of the toweling into the housing using the motor assembly as a function of sensing the leading edge of the toweling by the sensor. Also, in embodiments that incorporate this feature, but not all such embodiments, the housing comprises a main body, and a loading door that is configured to rotate relative to the main body between a closed position, in which the housing is configured to extend toweling there from, and an open position, in which the housing is configured to receive toweling therein. Furthermore, the loading door comprises a towel carrier having a curved surface defining a cavity within which toweling comprising a roll of paper towels is received and retained in floating engagement therewith such that the roll of paper towels rolls and slides on the curved surface when unwinding during said step of extending the toweling exterior of the housing for grasping by a user. The toweling further gathers within the housing during retracting of the toweling into the housing and is not wound back onto the roll of paper towels. Still yet in embodiments that incorporate this feature, but not all such embodiments, the housing comprises a main body, a loading door that is configured to rotate relative to the main body between a closed position, in which the housing is configured to extend toweling there from, and an open position, in which the housing is configured to receive toweling therein, and a guide system that is configured to guide the toweling within the housing during extension from and retraction into the housing of the toweling, the guide system comprising a first roller attached to the main body and having a first toothed surface, and a second roller attached to the loading door and having a second toothed surface that is configured to mesh with the first toothed surface. In this respect, at least one end of the first roller moves such that an axis of rotation of the first roller moves relative to the main body of the housing, and the method further comprises the step of moving the loading door into the closed position after loading toweling within the dispenser, with the first roller being urged into engagement with the second roller when the loading door enters the closed position and the second roller acting on the first roller so as to displace at least one end of the first roller when the loading door enters the closed position.

[072] In another feature, each extension wall is integral with the main body of the housing.

[073] In a feature, each extension wall is integrally formed with the main body of the housing.

[074] In a feature, each extension wall extends opposite side walls of the housing beyond the top side of the housing.

[075] In a feature, each extension wall is configured to be broken off by hand upon bending along a weakened line of the extension wall.

[076] In a feature, each extension wall includes a plurality of weakened lines.

[077] In a feature, weakened line of an extension wall extends in parallel to, and at the same height from the top side of the housing, as a corresponding weakened line of the other extension wall.

[078] In another aspect of the invention, a towel dispenser comprises a housing for receiving toweling comprising a roll of paper towels, the housing in turn comprising extension walls located proximate opposite exterior sides of the housing that extends above a top side of the housing, each extension wall comprising a weakened line extending parallel to a weakened line of the other extension walls, whereby the extent above the top side at which each extension walls extends may be changed, the extent representing a distance from the underside of a fixture below which the top side of the housing is mounted when the towel dispenser is installed under the fixture.

[079] In a feature of this aspect, a back side of the housing includes an opening configured to permit excess toweling to fall there through during retraction of the toweling into the housing. In some embodiments incorporating this feature, but not all such embodiments, the housing further comprises a motor assembly configured to cause a leading edge of the toweling to be extended from the housing and to cause the toweling to be retracted into the housing after the leading edge has been extended; and a sensor for sensing a leading edge of the toweling during retraction of the toweling by the motor assembly. The sensor is configured to cause the motor assembly to cease retracting the toweling into the housing as a function of the sensing of the leading edge of the toweling during retraction of the toweling into the housing. Also, in some embodiments incorporating this feature, but not all such embodiments, the housing comprises a main body and a loading door that is configured to rotate relative to the main body between a closed position, in which the housing is configured to extend toweling there from, and an open position, in which the housing is configured to receive toweling therein. The loading door comprises a towel carrier having a curved surface defining a cavity configured to receive the roll of paper towels in floating engagement therewith such that the roll of paper towels rolls and slides on the curved surface during unwinding.

[080] In another feature of this aspect, the towel dispenser includes a housing that, in turn, comprises a main body, a loading door, and a guide system. The loading door is configured to rotate relative to the main body between a closed position, in which the housing is configured to extend toweling there from, and an open position, in which the housing is configured to receive toweling therein. The guide system is configured to guide the toweling within the housing during extension from and retraction into the housing of the toweling, the guide system comprising a first roller attached to the main body and having a first toothed surface, and a second roller attached to the loading door and having a second toothed surface that is configured to mesh with the first toothed surface. At least one end of the first roller moves such that an axis of rotation of the first roller moves relative to the main body of the housing, the first roller is spring biased toward engagement with the second roller when the

loading door is in the closed position, and the toothed surfaces of the first roller and the second roller mesh together when the loading door moves into the closed position from the open position and do not preclude the loading door from moving into the closed position from the open position.

[081] In another aspect, a method of dispensing towels from toweling with a dispenser includes the steps of: extending the toweling exterior of a housing of the dispenser for grasping by a user; and subsequent thereto, retracting the toweling into the housing. The toweling comprises a roll of paper towels and the dispenser is configured to unwind roll of paper towels during extension of toweling from the housing but not rewind the roll of paper towels during subsequent retraction of toweling into the housing, and a back side of the housing includes an opening that is configured such that excess toweling gathering within the housing may fall as a result of retraction of toweling back into the housing.

[082] In a feature of this aspect, the method further includes the steps of: using a motor assembly configured to cause a leading edge of the toweling to be extended from a housing of the dispenser and to cause the toweling to be subsequently retracted back into the housing, performing said steps of extending the toweling exterior of the housing for grasping by a user and subsequent thereto, retracting the toweling into the housing; and, using a sensor for sensing a leading edge of the toweling, sensing a leading edge of the toweling while retracting the toweling; ceasing retracting of the toweling into the housing using the motor assembly as a function of sensing the leading edge of the toweling by the sensor. Further in this respect, the housing comprises a main body, a loading door, and a guide system. The loading door is configured to rotate relative to the main body between a closed position, in which the housing is configured to extend toweling there from, and an open position, in which the housing is configured to receive toweling therein. The guide system is configured to guide the toweling within the housing during extension from and retraction into the housing of the toweling, the guide system comprising a first roller attached to the main body and having a first toothed surface, and a second roller attached to the loading door and having a second toothed surface that is configured to mesh with the first toothed surface, at least one end of the first roller being configured to move such that an axis of rotation of the first roller moves relative to the main body of the housing. The loading door further comprises a towel carrier having a curved surface defining a cavity within which toweling comprising a roll of paper towels is received and retained in floating engagement therewith, the roll of paper towels rolling and sliding on the curved surface when unwinding during said step of extending the toweling exterior of the housing for grasping by a user, and toweling gathering within the housing during retracting of the toweling into the housing and not being wound back onto the roll of paper towels. Additionally, the method further comprises the step of moving the loading door into the closed position after loading toweling within the dispenser, with the first roller being urged into engagement with the second roller when the loading door enters the closed position and the second roller acting on the first roller so as to displace at least one end of the first roller when the loading door enters the closed position.

[083] In a feature of this aspect, the method further comprises the steps of: using a motor assembly configured to cause a leading edge of the toweling to be extended from a housing of the dispenser and to cause the toweling to be subsequently retracted back into the housing, performing said steps of extending the toweling exterior of the housing for grasping by a user and subsequent thereto, retracting the toweling into the housing; using a sensor for sensing a leading edge of the toweling, sensing a leading edge of the toweling while retracting the toweling; and ceasing retracting of the toweling into the housing using the motor assembly as a function of sensing the leading edge of the toweling by the sensor. Further in this respect, the housing comprises a main body, a loading door, and a guide system. The loading door is configured to rotate relative to the main body between a closed position, in which the housing is configured to extend toweling there from, and an open position, in which the housing is configured to receive toweling therein. The loading door further comprises a towel carrier having a curved surface defining a cavity within which toweling comprising a roll of paper towels is received and retained in floating engagement therewith, the roll of paper towels rolling and sliding on the curved surface when unwinding during said step of extending the toweling exterior of the housing for grasping by a user, and toweling gathering within the housing during retracting of the toweling into the housing and not being wound back onto the roll of paper towels. The housing comprises extension walls located proximate opposite exterior sides of the housing that extend above a top side of the housing, and wherein the method further comprises a preliminary step of mounting the dispenser to the underside of a fixture, including removing a portion of each extension wall along a score line so as to adjust the distance from the underside of the fixture below which the top side of the housing is mounted.

[084] In a feature of this aspect, the housing comprises a main body and a loading door that is configured to rotate relative to the main body between a closed position, in which the housing is configured to extend toweling there from, and an open position, in which the housing is configured to receive toweling therein. The housing also comprise a guide system that is configured to guide the toweling within the housing during extension from and retraction into the housing of the toweling, the guide system comprising a first roller attached to the main body and having a first toothed surface, and a second roller attached to the loading door and having a second toothed surface that is configured to mesh with the first toothed surface, at least one end of the first roller being configured to move such that an axis of rotation of the first roller moves relative to the main body of the housing. Further in this respect, the loading door comprises a towel carrier having a curved surface defining a cavity within which toweling comprising a roll of paper towels is received and retained in floating engagement therewith, the roll of paper towels rolling and sliding on the curved surface when unwinding during said step of extending the toweling exterior of the housing for grasping by a user, and toweling gathering within the housing during retracting of the toweling into the housing and not being wound back onto the roll of paper towels; the method further comprises the step of moving the loading door into the closed position after loading toweling within the dispenser, with the first roller

being urged into engagement with the second roller when the loading door enters the closed position and the second roller acting on the first roller so as to displace at least one end of the first roller when the loading door enters the closed position; and wherein the housing comprises extension walls located proximate opposite exterior sides of the housing that extend above a top side of the housing, and wherein the method further comprises a preliminary step of mounting the dispenser to the underside of a fixture, including removing a portion of each extension wall along a score line so as to adjust the distance from the underside of the fixture below which the top side of the housing is mounted.

[085] In a feature of this aspect, the method further comprises the steps of: using a motor assembly configured to cause a leading edge of the toweling to be extended from a housing of the dispenser and to cause the toweling to be subsequently retracted back into the housing, performing said steps of extending the toweling exterior of the housing for grasping by a user and subsequent thereto, retracting the toweling into the housing; using a sensor for sensing a leading edge of the toweling, sensing a leading edge of the toweling while retracting the toweling; and ceasing retracting of the toweling into the housing using the motor assembly as a function of sensing the leading edge of the toweling by the sensor. The housing comprises a main body, a loading door, and a guide system. The loading door is configured to rotate relative to the main body between a closed position, in which the housing is configured to extend toweling there from, and an open position, in which the housing is configured to receive toweling therein. The guide system is configured to guide the toweling within the housing during extension from and retraction into the housing of the toweling, the guide system comprising a first roller attached to the main body and having a first toothed surface, and a second roller attached to the loading door and having a second toothed surface that is configured to mesh with the first toothed surface, at least one end of the first roller being configured to move such that an axis of rotation of the first roller moves relative to the main body of the housing. Further in this respect, the method further comprises the step of moving the loading door into the closed position after loading toweling within the dispenser, with the first roller being urged into engagement with the second roller when the loading door enters the closed position and the second roller acting on the first roller so as to displace at least one end of the first roller when the loading door enters the closed position; and the housing comprises extension walls located proximate opposite exterior sides of the housing that extend above a top side of the housing, and wherein the method further comprises a preliminary step of mounting the dispenser to the underside of a fixture, including removing a portion of each extension wall along a score line so as to adjust the distance from the underside of the fixture below which the top side of the housing is mounted.

[086] In yet another feature of this aspect, the method further comprises the steps of: using a motor assembly configured to cause a leading edge of the toweling to be extended from a housing of the dispenser and to cause the toweling to be subsequently retracted back into the housing, performing said steps of extending the toweling exterior of the housing for grasping by a user and subsequent

thereto, retracting the toweling into the housing; using a sensor for sensing a leading edge of the toweling, sensing a leading edge of the toweling while retracting the toweling; and ceasing retracting of the toweling into the housing using the motor assembly as a function of sensing the leading edge of the toweling by the sensor. Further in this respect, the housing comprises a main body, a loading door, and a guide system. The loading door is configured to rotate relative to the main body between a closed position, in which the housing is configured to extend toweling there from, and an open position, in which the housing is configured to receive toweling therein. The guide system is configured to guide the toweling within the housing during extension from and retraction into the housing of the toweling, the guide system comprising a first roller attached to the main body and having a first toothed surface, and a second roller attached to the loading door and having a second toothed surface that is configured to mesh with the first toothed surface, at least one end of the first roller being configured to move such that an axis of rotation of the first roller moves relative to the main body of the housing. The loading door comprises a towel carrier having a curved surface defining a cavity within which toweling comprising a roll of paper towels is received and retained in floating engagement therewith, the roll of paper towels rolling and sliding on the curved surface when unwinding during said step of extending the toweling exterior of the housing for grasping by a user, and toweling gathering within the housing during retracting of the toweling into the housing and not being wound back onto the roll of paper towels. Furthermore, the method additionally comprises the step of moving the loading door into the closed position after loading toweling within the dispenser, with the first roller being urged into engagement with the second roller when the loading door enters the closed position and the second roller acting on the first roller so as to displace at least one end of the first roller when the loading door enters the closed position. The housing also further comprises extension walls located proximate opposite exterior sides of the housing that extend above a top side of the housing, and wherein the method further comprises a preliminary step of mounting the dispenser to the underside of a fixture, including removing a portion of each extension wall along a score line so as to adjust the distance from the underside of the fixture below which the top side of the housing is mounted.

[087] In still yet another aspect of the invention, a towel dispenser comprises a housing for receiving toweling. The housing in turn comprises a main body, a loading door, a guide system, and a motor assembly. The loading door is configured to rotate relative to the main body between a closed position, in which the housing is configured to dispense towels there from, and an open position, in which the housing is configured to receive toweling therein. The guide system is configured to guide the toweling within the housing while towels are dispensed from the housing. The motor assembly is configured to cause a leading edge of the toweling to be extended from the housing and to cause the toweling to be retracted into the housing after the leading edge has been extended. Furthermore, a back side of the housing includes an opening configured to permit excess toweling to fall there through during retraction of the toweling back into the housing by the motor assembly.

[088] In a feature of this aspect, the towel dispenser further comprises a sensor for sensing a leading edge of the toweling during retraction of the toweling by the motor assembly. The sensor is configured to cause the motor assembly to cease retracting the toweling into the housing as a function of the sensing of the leading edge of the toweling during retraction of the toweling into the housing. Additionally, the guide system comprises a first roller attached to the main body and having a first toothed surface, and a second roller attached to the loading door and having a second toothed surface that is configured to mesh with the first toothed surface; the loading door comprises a towel carrier having a curved surface defining a cavity configured to receive the roll of paper towels in floating engagement therewith such that the roll of paper towels rolls and slides on the curved surface during unwinding; at least one end of the first roller moves such that an axis of rotation of the first roller moves relative to the main body of the housing; the first roller is spring biased toward engagement with the second roller when the loading door is in the closed position; and the toothed surfaces of the first roller and the second roller mesh together when the loading door moves into the closed position from the open position and do not preclude the loading door from moving into the closed position from the open position.

[089] In a feature of this aspect, the towel dispenser further comprises a sensor for sensing a leading edge of the toweling during retraction of the toweling by the motor assembly. The sensor is configured to cause the motor assembly to cease retracting the toweling into the housing as a function of the sensing of the leading edge of the toweling during retraction of the toweling into the housing. Moreover, the loading door comprises a towel carrier having a curved surface defining a cavity configured to receive the roll of paper towels in floating engagement therewith such that the roll of paper towels rolls and slides on the curved surface during unwinding; and the housing further comprises extension walls located proximate opposite exterior sides of the housing that extends above a top side of the housing, each extension wall comprising a weakened line extending parallel to a weakened line of the other extension walls, whereby the extent above the top side at which each extension walls extends may be changed, the extent representing a distance from the underside of a fixture below which the top side of the housing is mounted when the towel dispenser is installed under the fixture.

[090] In still another feature of this aspect, the guide system comprises a first roller attached to the main body and having a first toothed surface, and a second roller attached to the loading door and having a second toothed surface that is configured to mesh with the first toothed surface; the loading door comprises a towel carrier having a curved surface defining a cavity configured to receive the roll of paper towels in floating engagement therewith such that the roll of paper towels rolls and slides on the curved surface during unwinding; at least one end of the first roller moves such that an axis of rotation of the first roller moves relative to the main body of the housing; the first roller is spring biased toward engagement with the second roller when the loading door is in the closed position; the toothed surfaces of the first roller and the second roller mesh together when the loading door moves

into the closed position from the open position and do not preclude the loading door from moving into the closed position from the open position; and the housing further comprises extension walls located proximate opposite exterior sides of the housing that extends above a top side of the housing, each extension wall comprising a weakened line extending parallel to a weakened line of the other extension walls, whereby the extent above the top side at which each extension walls extends may be changed, the extent representing a distance from the underside of a fixture below which the top side of the housing is mounted when the towel dispenser is installed under the fixture.

[091] In a feature of this aspect, the towel dispenser further comprises a sensor for sensing a leading edge of the toweling during retraction of the toweling by the motor assembly. The sensor is configured to cause the motor assembly to cease retracting the toweling into the housing as a function of the sensing of the leading edge of the toweling during retraction of the toweling into the housing. Moreover, the guide system comprises a first roller attached to the main body and having a first toothed surface, and a second roller attached to the loading door and having a second toothed surface that is configured to mesh with the first toothed surface; at least one end of the first roller moves such that an axis of rotation of the first roller moves relative to the main body of the housing; the first roller is spring biased toward engagement with the second roller when the loading door is in the closed position; and the toothed surfaces of the first roller and the second roller mesh together when the loading door moves into the closed position from the open position and do not preclude the loading door from moving into the closed position from the open position. Furthermore, the housing further comprises extension walls located proximate opposite exterior sides of the housing that extends above a top side of the housing, each extension wall comprising a weakened line extending parallel to a weakened line of the other extension walls, whereby the extent above the top side at which each extension walls extends may be changed, the extent representing a distance from the underside of a fixture below which the top side of the housing is mounted when the towel dispenser is installed under the fixture.

[092] In a feature of this aspect, the towel dispenser further comprises a sensor for sensing a leading edge of the toweling during retraction of the toweling by the motor assembly. The sensor is configured to cause the motor assembly to cease retracting the toweling into the housing as a function of the sensing of the leading edge of the toweling during retraction of the toweling into the housing. Moreover, the guide system comprises a first roller attached to the main body and having a first toothed surface, and a second roller attached to the loading door and having a second toothed surface that is configured to mesh with the first toothed surface; the loading door comprises a towel carrier having a curved surface defining a cavity configured to receive the roll of paper towels in floating engagement therewith such that the roll of paper towels rolls and slides on the curved surface during unwinding; at least one end of the first roller moves such that an axis of rotation of the first roller moves relative to the main body of the housing; the first roller is spring biased toward engagement with the second roller when the loading door is in the closed position; the toothed surfaces of the first

roller and the second roller mesh together when the loading door moves into the closed position from the open position and do not preclude the loading door from moving into the closed position from the open position; and the housing further comprises extension walls located proximate opposite exterior sides of the housing that extends above a top side of the housing, each extension wall comprising a weakened line extending parallel to a weakened line of the other extension walls, whereby the extent above the top side at which each extension walls extends may be changed, the extent representing a distance from the underside of a fixture below which the top side of the housing is mounted when the towel dispenser is installed under the fixture.

[093] In another aspect of the invention, a towel dispenser comprises: a housing for receiving toweling, wherein the toweling includes towels that are connected together and separable at perforation formed between the towels; a motor configured to selectively cause a leading edge of the toweling to be extended from the housing and to cause the toweling to be retracted into the housing; and a sensor for sensing a leading edge of the toweling. The sensor is configured to cause the motor to cease retracting toweling into the housing in response to the sensing of the leading edge of the toweling.

[094] In still yet another aspect of the invention, a method of dispensing towels from a dispenser includes the steps of: providing (i) a towel dispenser including a housing for containing toweling, wherein the toweling includes towels connected together and separable at perforations formed there between, (ii) a motor configured to selectively cause a leading edge of the toweling to be extended from the housing and to cause the toweling to be retracted into the housing, and (iii) a sensor for sensing a leading edge of the toweling; using the motor, extending the toweling exterior of the housing for grasping by a user; using the motor, retracting the toweling into the housing; while retracting the toweling, sensing a leading edge of the toweling using the sensor; and ceasing to retract the toweling into the housing using the motor upon sensing the leading edge of the toweling by the sensor. Other aspects of the invention relate to structure of towel dispensers as disclosed herein.

[095] In another aspect of the invention, a method includes advancing toweling using a motor of a paper towel dispenser apparatus; determining, via a sensor, when a certain extent of toweling has been advanced; based on said determining when a certain extent of toweling has been advanced, ceasing the advance of the advancing toweling, wherein, upon ceasing the advance of the advancing toweling, a first length of toweling is extended outside of a housing of the paper towel dispenser apparatus; determining, via the sensor, that the length of toweling extended outside of the housing has increased, wherein a second length of toweling is extended outside of the housing of the paper towel dispenser apparatus, the second length being greater than the first length; and in response to said determining that the length of toweling extended outside of the housing has increased, applying force to the toweling, via the motor, in a manner adapted to retract the toweling such that the length of toweling extended outside of the housing decreases.

[096] In a feature of this aspect, said step of applying force to the toweling, via the motor, in a manner adapted to retract the toweling such that the length of toweling extended outside of the housing decreases comprises applying force to the toweling, via the motor, in a manner adapted to retract the toweling such that the length of toweling extended outside of the housing is once again the first length.

[097] In a feature of this aspect, said step of advancing toweling comprises providing current of a first polarity to the motor; said step of ceasing the advance of the advancing toweling comprises drawing current out of the motor; and said step of applying force to the toweling, via the motor, comprises providing current of a second polarity to the motor, the second polarity being reverse of the first polarity.

[098] In a feature of this aspect, the sensor comprises a slot sensor.

[099] In another aspect of the invention, a method includes, when a length of toweling is extended outside of a housing of a paper towel dispenser, determining, via a sensor, that the length of toweling extended outside of the housing of the paper towel dispenser has increased; and in response to said determining that the length of toweling extended outside of the housing has increased, applying force to the toweling, via the motor, in a manner adapted to retract the toweling such that the length of toweling extended outside of the housing decreases.

[0100] In a feature of this aspect, said step of applying force to the toweling, via the motor, in a manner adapted to retract the toweling such that the length of toweling extended outside of the housing decreases comprises applying force to the toweling, via the motor, in a manner adapted to retract the toweling such that the length of toweling extended outside of the housing is once again the first length.

[0101] In a feature of this aspect, the sensor comprises a slot sensor.

[0102] In another aspect of the invention, a method includes advancing toweling using a motor of a paper towel dispenser apparatus; monitoring, via a sensor, rotation that occurs as toweling is advanced or retracted; determining, via the sensor, that a certain amount of rotation has occurred; based on said determining that a certain amount of rotation has occurred, ceasing the advance of the advancing toweling; after said ceasing of the advance of the advancing toweling, determining, via the sensor, that additional rotation has occurred; and in response to said determining that a certain amount of rotation has occurred, applying force, via the motor, in a manner adapted to counteract the additional rotation.

[0103] In a feature of this aspect, said step of applying force, via the motor, in a manner adapted to counteract the additional rotation comprises effecting rotation in a direction opposite the direction of the additional rotation.

[0104] In a feature of this aspect, said step of advancing toweling comprises providing current of a first polarity to the motor; said step of ceasing the advance of the advancing toweling comprises drawing current out of the motor; and said step of applying force to the toweling, via the motor,

comprises providing current of a second polarity to the motor, the second polarity being reverse of the first polarity.

[0105] In a feature of this aspect, the sensor comprises a slot sensor.

[0106] Still other aspects of the invention relate to methods and operational logic of towel dispensers as disclosed herein.

[0107] Still yet other aspects and features may be found in the incorporated patent publication.

[0108] In addition to the aforementioned aspects and features of the present invention, it should be noted that the present invention further encompasses the various possible combinations and subcombinations of such aspects and features. Thus, for example, any aspect may be combined with an aforementioned feature in accordance with the present invention without requiring any other aspect or feature.

#### BRIEF DESCRIPTION OF THE DRAWINGS

[0109] One or more preferred embodiments of the present invention are represented in the drawings, wherein:

[0110] FIG. 1 is perspective view of part of an automatic paper towel dispenser apparatus in accordance with an embodiment of the invention.

[0111] FIG. 2 is an isometric view of part of the automatic paper towel dispenser apparatus of FIG. 1 illustrating a top drive mechanism.

[0112] FIG. 3 is a perspective view of part of the automatic paper towel dispenser apparatus of FIG. 1, with the front cover removed to show the battery holder and control circuitry.

[0113] FIG. 4 is a cross-sectional view of part of the automatic paper towel dispenser apparatus of FIG. 1, showing the spring mechanism that allows an end of the top driven roller to move vertically, which compensates for both paper thickness variations and manufacturing tolerances.

[0114] FIG. 5 is a cross-sectional view of part of the automatic paper towel dispenser apparatus of FIG. 1, through the center of the device, showing the drive roller orientation, slotted encoder wheel for measuring toweeling length, and loading door including a lower material guide in the closed position.

[0115] FIG. 6 is another cross-sectional view of part of the automatic paper towel dispenser apparatus of FIG. 1, through the center of the device, showing the drive roller orientation, slotted encoder wheel, and loading door in the open position.

[0116] FIG. 7 is a perspective view of part of an automatic paper towel dispenser apparatus in accordance with an embodiment of the invention, in which the loading door open is open and the dispenser apparatus is ready to receive a roll of paper towels.

[0117] FIG. 8 is a perspective view of part of an automatic paper towel dispenser apparatus of FIG. 7, in which a roll of paper towels has been placed in the loading door, with a section of the toweeling

removed from the roll and draped over the roller of the loading door whereby an IR sensor at the front lip of the device can detect the toweling.

[0118] FIG. 9 is a perspective view of part of an automatic paper towel dispenser apparatus of FIG. 8, wherein the loading door has been closed with a length of the toweling extending from the housing, whereupon the length learn sequence is initiated.

[0119] FIG. 10 is a partial perspective view of an automatic paper towel dispenser apparatus in accordance with an embodiment of the invention, in which the automatic paper towel dispenser is installed under a cabinet and a user is in the process of tearing the toweling.

[0120] FIG. 11 is a partial perspective view of an automatic paper towel dispenser apparatus in accordance with an embodiment of the invention, in which the front cover of the automatic paper towel dispenser apparatus has been removed for access to the batteries, which comprise 4 D cells.

[0121] FIG. 12 is a partial perspective view of an automatic paper towel dispenser apparatus in accordance with an embodiment of the invention, in which is shown the connection of an optional 6V DC power supply for powering the internal motor of the automatic paper towel dispenser apparatus.

[0122] FIG. 13 is an illustration of the 6V, 3.5A, AC/DC power supply used with an embodiment of the invention.

[0123] FIGS. 14A and 14B collectively illustrate a block diagram representing operational logic in accordance with an embodiment of the invention.

[0124] FIGS. 15A and 15B each represents an exemplary electronic schematic diagram for control circuitry utilized in different embodiments of automatic paper towel dispenser apparatus in accordance with the invention.

[0125] FIG. 16 is a front elevation view of part of an automatic paper towel dispenser apparatus in accordance with an embodiment of the invention.

[0126] FIG. 17 is a rear elevation view of part of the automatic paper towel dispenser apparatus of FIG. 16.

[0127] FIG. 18 is a left side elevation view of part of the automatic paper towel dispenser apparatus of FIG. 16.

[0128] FIG. 19 is a right side elevation view of part of the automatic paper towel dispenser apparatus of FIG. 16.

[0129] FIG. 20A is a top plan view of part of the automatic paper towel dispenser apparatus of FIG. 16, and FIG. 20B is the same view with the top panel omitted.

[0130] FIG. 21 is a bottom plan view of part of the automatic paper towel dispenser apparatus of FIG. 16.

[0131] FIG. 22A is an isometric view of part of the automatic paper towel dispenser apparatus of FIG. 16, FIG. 22B is the same view with the top panel omitted.

[0132] FIG. 23 is an isometric view of part of the automatic paper towel dispenser apparatus of FIG. 16.

[0133] FIG. 24 is an exploded, isometric view of part of the automatic paper towel dispenser apparatus of FIG. 16.

[0134] FIG. 25 is a flowchart detailing exemplary functionality of a paper towel dispenser apparatus in accordance with one or more embodiments of the invention.

[0135] FIGS. 26-34 illustrate an exemplary dispensing sequence for a paper towel dispenser apparatus in accordance with one or more embodiments of the invention.

#### DETAILED DESCRIPTION

[0136] As a preliminary matter, it will readily be understood by one having ordinary skill in the relevant art (“Ordinary Artisan”) that the present invention has broad utility and application. Furthermore, any embodiment discussed and identified as being “preferred” is considered to be part of a best mode contemplated for carrying out the present invention. Other embodiments also may be discussed for additional illustrative purposes in providing a full and enabling disclosure of the full scope of the present invention that is contemplated. Moreover, many embodiments, such as adaptations, variations, modifications, and equivalent arrangements, will be implicitly disclosed by the embodiments described herein and fall within the scope of the present invention.

[0137] Accordingly, while the present invention is described herein in detail in relation to one or more embodiments, it is to be understood that this disclosure is illustrative and exemplary of the present invention, and is made merely for the purposes of providing a full and enabling disclosure of the present invention. The detailed disclosure herein of one or more embodiments is not intended, nor is to be construed, to limit the scope of patent protection afforded the present invention, which scope is to be defined by the claims and the equivalents thereof. It is not intended that the scope of patent protection afforded the present invention be defined by reading into any claim a limitation found herein that does not explicitly appear in the claim itself.

[0138] Thus, for example, any sequence(s) and/or temporal order of steps of various processes or methods that are described herein are illustrative and not restrictive. Accordingly, it should be understood that, although steps of various processes or methods may be shown and described as being in a sequence or temporal order, the steps of any such processes or methods are not limited to being carried out in any particular sequence or order, absent an indication otherwise. Indeed, the steps in such processes or methods generally may be carried out in various different sequences and orders while still falling within the scope of the present invention. Accordingly, it is intended that the scope of patent protection afforded the present invention is to be defined by the appended claims rather than the description set forth herein.

[0139] Additionally, it is important to note that each term used herein refers to that which the Ordinary Artisan would understand such term to mean based on the contextual use of such term herein. To the extent that the meaning of a term used herein—as understood by the Ordinary Artisan

based on the contextual use of such term—differs in any way from any particular dictionary definition of such term, it is intended that the meaning of the term as understood by the Ordinary Artisan should prevail.

[0140] Furthermore, it is important to note that, as used herein, “a” and “an” each generally denotes “at least one,” but does not exclude a plurality unless the contextual use dictates otherwise. Thus, reference to “a picnic basket having an apple” describes “a picnic basket having at least one apple” as well as “a picnic basket having apples.” In contrast, reference to “a picnic basket having a single apple” describes “a picnic basket having only one apple.”

[0141] When used herein to join a list of items, “or” denotes “at least one of the items,” but does not exclude a plurality of items of the list. Thus, reference to “a picnic basket having cheese or crackers” describes “a picnic basket having cheese without crackers”, “a picnic basket having crackers without cheese”, and “a picnic basket having both cheese and crackers.” Finally, when used herein to join a list of items, “and” denotes “all of the items of the list.” Thus, reference to “a picnic basket having cheese and crackers” describes “a picnic basket having cheese, wherein the picnic basket further has crackers,” as well as describes “a picnic basket having crackers, wherein the picnic basket further has cheese.”

[0142] Referring now to the drawings, embodiments of the present invention are next described. The following description of the embodiments is merely exemplary in nature and is in no way intended to limit the invention, its implementations, or uses.

[0143] Turning now to the drawings, FIG. 1 illustrates a perspective view of an automatic paper towel dispenser apparatus **10** in accordance with one embodiment of the present invention. The apparatus **10** dispenses common, readily available, perforated paper towels. Furthermore, the apparatus has a learning capability, giving it the ability to detect and dispense towels of varying lengths, including full sheets, half sheets, multiple sheets, and abnormally sized sheets. Therefore, a wide variety of perforated towels can be used with the apparatus, including any brand or length available at retail.

[0144] FIG. 2 is an isometric view of the apparatus **10** and FIG. 3 is a perspective view of the apparatus **10**. FIG. 2 shows the top drive mechanism **12** of the towel dispenser apparatus **10**. FIG. 3 shows the apparatus with the front cover **14** removed, displaying the battery holder **16** and control circuitry **18**. Preferably, the apparatus **10** may be powered by either batteries **20** (as shown in FIG. 3) or an AC/DC adapter **22** (such as the one illustrated in FIG. 13).

[0145] The apparatus **10** is intended to be mounted under kitchen cabinetry, or on the underside of any sufficiently sized shelf. Four screws **24** interface with thread inserts in the main structure of the dispenser **10**. Installation involves drilling four holes, positioned with a supplied template. Some features have been included to allow a level of installation customization. Kitchen cabinets are constructed in a number of ways. If a recess exists under a cabinet, the dispenser can be mounted

with the supplied spacers **13**. These spacers slide onto the screws. They can be stacked and combined to achieve three height offsets for the dispenser.

[0146] Furthermore, if spacers are used, a gap between the dispenser and underside of the cabinet may be visible from some angles. To address this aesthetic issue, trim tabs **50** have been designed into the exterior side covers of the apparatus **10**. These trim tabs **50** are simply molded with the side covers, and can be folded over or snapped off at scores **52** (or otherwise bent) as desired in order to accommodate spacing between the top panel of the apparatus and the bottom of the underside of the cabinet.

[0147] As an alternative to the spacers, it is contemplated that a bracket may be used for mounting the dispenser.

[0148] Use of the device begins by deciding on the source of power. Four D batteries **20** can be used to supply the necessary 6V input, or a 6V, 3.5A AC/DC adapter **22** can be connected via a standard 5 mm input jack, as illustrated in FIG. 12. If the AC/DC adapter **22** is selected, power from the batteries **20** is interrupted, protecting the circuitry **18** from over voltage damage. Specifically, plugging in the connector of the adapter into the housing of the dispenser apparatus **100** breaks the battery circuit, thereby preventing parallel connection of the batteries and AC/DC supply. An off the shelf DC jack with a ground interrupt loop, KOBICONN 163-MJ21-EX, provides this switching protection.

[0149] FIGS. 7-9 are photographs showing steps in a sequence of installing toweling into an automatic paper towel dispenser apparatus **100** in accordance with an embodiment of the invention. FIGS. 14A and 14B collectively illustrate a block diagram describing operational logic that is implemented in the automatic paper towel dispenser apparatus **100**; and FIG. 15A is an electronic schematic diagram for control circuitry that may be utilized in automatic paper towel dispenser apparatus in accordance with at least one embodiment of the invention. FIG. 15B is an alternative electronic schematic diagram for control circuitry that may be utilized in automatic paper towel dispenser apparatus in accordance with at least one other embodiment of the invention, wherein, *inter alia*, a single position sensor is utilized.

[0150] A latch mechanism is released to open apparatus **100**. This latch is operated by a sliding pull handle located on the underside of the front section of the dispenser. FIG. 7 shows the apparatus **100** in the open position and ready to accept a roll of paper towels. The lower driver roller moves with the towel carrier. This feature greatly simplifies installation of the toweling. In conventional dispensers, tensioning devices and a convoluted feeding route need to be understood by the operator. In apparatus **100**, the operator simply installs a roll of towels with the first towel draped over the lower drive roller and closes the device. There is no requirement for the toweling to be threaded through any path defined by rollers and tensioning devices.

[0151] Included in the rotating towel carrier subassembly is a magnet that interfaces with a hall-effect transducer resident on the main circuit board. Output from the hall-effect transducer notifies

the microcontroller of the position of the towel carrier door. Each time the door is opened, the device is reset. Upon closing the door, the microcontroller initiates a "Length Learn" program sequence.

[0152] With particular regard to the "Length Learn" program sequence, the apparatus **100** first retracts the toweling until output from the "S1" positioning reflective IR sensor indicates that no paper is present, i.e., that a leading edge of the toweling has been sensed. This reflective sensor is located at the front and top of the dispensing slot. It is mounted to the main circuit board, and protrudes through an opening that keeps it flush with the dispensing slot top surface. Position of the towel's edge has now been determined. Preferably, a known length, such as twelve inches of paper towel, is then dispensed although a greater length may be dispensed, especially if the user desired dispensing of more than one towel at a time.

[0153] The length of toweling that is dispensed is determined by driving the motor in the forward direction a predetermined number of encoder counts, or "Drive Length Units". Length corresponds to counts. Counts correspond to both edges of openings in a slotted wheel axially mounted to the top roller shaft. Output from a slot type IR sensor, TT Optek OPB891T51Z, is used by the microcontroller to count. A pause in the program, referred to as the "Tear Time Interval", allows an operator to interact with the dispenser. Towel length for all subsequent dispensing is determined by tearing off a length of towel at any desired perforated position. "Tear Time Interval" concludes and the dispenser again retracts until the reflective IR sensor detects the leading edge of the toweling. While reversing, the microcontroller again uses the encoder to count openings in the slotted wheel, sometimes referred to as an encoder pinwheel. "Retract Length Units", reverse counts, are used to determine "Learned Towel Length", whereupon the "Length Learn" program sequence is completed. The Learned Towel Length or LTL is determined by subtracting the Retract Length Units or RLU from the Drive Length Units or DLU.

[0154] It further will be appreciated that technology other than an encoder pinwheel may be used as an alternative for measuring the extent to which the toweling is extended or retracted by the motor. For example, the technology conventionally found in an optical mouse may be utilized, which includes a tiny camera that takes thousands of pictures per second to determine position and speed. Conventionally, the optical mouse uses a very small light emitting diode more commonly referred to as an LED which is red in color. This LED bounces light off of a mouse pad or desk surface onto a CMOS (Complementary Metal Oxide Semiconductor).

[0155] In the context of the present invention, this same technology may be used to determine the extent of the toweling that is extended or retracted. In operation, the LED produces a red light that is emitted onto the toweling surface. The light is reflected off the surface back to the CMOS sensor. The CMOS sensor sends each image that is reflected back to a DSP (Digital Signal Processor) for analysis. Using the thousands of images (taken at hundreds of times per second) that the CMOS sends to the DSP for analysis, the DSP is able to detect both patterns and images and can determine if the toweling has moved, at what distance it has moved, and at what speed.

[0156] Yet another alternative technology includes that found in laser-based optical mice, which technology piggy backs off of the LED optical mouse. The laser based optical mouse works similar to the LED based optical mouse. It uses a laser instead of a LED. The benefit is that because it uses a laser beam, the mouse can track much better, giving the user ultimately better response times, tracking and the ability for such a mouse to be used on even more surfaces. In the context of the present invention, it is believed that use of such laser technology would provide greater precision and accuracy in determining the extent of the toweling that is extended or retracted.

[0157] Furthermore, the housing in the area of the detection of the toweling surface preferably is dark and contrasts well with the toweling so as to better define the leading edge of the toweling for detection, whether the IR, optical or laser technology is used.

[0158] After the LTL is learned, the operator engages the "Hand Wave" sensor to dispense a towel. The reflective IR sensor shown in the drawings is interfaced with through a lens located in the center of the front fascia panel. The sensor emitter and detector are mounted directly to the main circuit board. Therefore, they do not move with the removable fascia panel. As a result, their placement, and proper installation of the fascia panel, is important to check for correct operation.

[0159] After the "Length Learn" sequence is completed, the dispenser's microcontroller enters a program that constantly looks at the "Hand Wave" sensor for output. Some level of ambient IR light is always present. Also, people and objects may continually pass in front of the device with no intention of initiating towel dispensing. Preferably, "Hand Wave" sensor output voltage is sampled and compared to avoid false initiation. The sample rate may be every 10 milliseconds, for example.

[0160] When an operator or user intends to dispense a towel, "Hand Wave" sensor voltage is substantially higher than ambient for a determined number of samples. At this point the motor is driven forward the "Learned Towel Length". To accommodate possible additional towels being desired by the user, the program delays for one tenth of the "Tear Time Interval", then reviews the "Hand Wave" sensor output. If a hand is still present, the toweling is extended an additional LTL. This additional dispensing sub-sequence will continue until a hand is no longer detected by the "Hand Wave" sensor. When a hand is no longer detected by the "Hand Wave" sensor, the "Tear Time Interval" is initiated, during which the operator is expected to tear off the desired paper towels from the dispensed toweling. After the "Tear Time Interval", the motor is driven in reverse until the positioning sensor "S1" again detects the leading edge (i.e., presumed new leading edge) of the toweling.

[0161] Alternatively, the motor is driven forward the number of desired LTLs (e.g., 1 LTL, 2 LTLs, or 3LTLs), plus a predetermined additional extent. The predetermined extent may be, for example, a distance between the point at which the leading edge of the toweling is detected by the sensor, and a point exterior of the housing and proximate to area at which the toweling exits the housing. In accordance with this alternative, a line of perforations should be found each time a towel is dispensed at a point exterior of the housing and proximate the area at which the toweling exits the housing. As

such, a small extent of the toweling following separation of the dispensed towels will be left extending outside of the housing and will be retracted back into the housing to the point at which the leading edge of the toweling is detected by the sensor. In accordance with this alternative, an operator will be able to clearly observe the particular line of perforations along which the tear is made.

[0162] Normal dispensing by the apparatus continues until all the towels on the roll have been dispensed, or until a dispensing error occurs.

[0163] All errors result in the bi-color indicator LED lighting red. An operator must open the device to reset the error condition. After any error, the “Length Learn” program will run again and the operator must teach the dispenser the desired dispense length.

[0164] Reliable paper feeding, without a specific paper to optimize the system around, is not trivial. Variations in thickness, friction coefficient, strength, surface area, and cross section must all be accommodated. Moreover, paper is removed by pulling with sufficient force to break the roll at a perforation, and this force also must be accommodated.

[0165] Several features have been designed to prevent malfunction, improve paper feed ability, and reliable operation. In particular, at least three main reliability features are provided in the apparatus **100** that are intended to prevent malfunction, improve paper feed ability, and reliable operation. Furthermore, it should be understood that, while embodiments of the invention may include only one or two—or none—of these features, other embodiments of the invention may include all three of these features.

[0166] The first reliability feature of the mechanism allows the upper drive roller to travel vertically. Two springs hold the roller in its lowest position. When the towel carrier is closed, the lower drive roller dictates the upper drive roller’s position. This addresses different towel thicknesses that will tend to push the upper roller to slightly different positions. With the spring loaded drive roller, thickness variations throughout the roll are constantly accounted for. This also addresses inherent manufacturing dimensional variation, within tolerances, that otherwise affects feed reliability, especially when injected molding with plastics.

[0167] The second reliability feature prevents unwanted movement of one or both rollers. Both rollers in this dispenser are driven. They are directly linked together (or directly interconnected) by a pair of axially mounted end gears. These gears have fairly large and forgiving tooth geometry. This is important, because of the unique ability to separate the rollers during paper installation. Opening the rollers enough for the entire roll to pass between them separates the gears completely. They must re-mesh, without damage or perceived difficulty, when the dispenser is closed.

[0168] The third reliability feature is software based. During the “Tear Time Interval” the motor has a percentage of the stall current applied in reverse. This applies force to the drive mechanism, preventing its movement, and allowing a very positive feel as the towel’s perforation is broken by the user pulling on the toweling portion extending from the housing. Indeed, even slow and consistent

pull on the extended toweling does not further extend toweling from the dispenser due, at least in part, to the application of reverse current.

[0169] Yet another automatic paper towel dispenser apparatus **200** in accordance with an embodiment of the invention is illustrated in FIGS. 16A through 23B. Operation and structure of apparatus **200** is similar to those disclosed above. Of additional note, FIG. 23A and FIG. 23B illustrate the open area within the housing, over the space for receiving a roll of paper towels, into which area toweling that is retracted into the housing may be directed. Moreover, if too much toweling is retracted into this area, the excess toweling likely falls out of the back of the apparatus, thereby avoiding possible jamming of the apparatus **200**. To this end, the back of the housing preferably is open when the door is closed, as shown in FIG. 23A and FIG. 23B.

[0170] Additional description of structure and functionality in accordance with one or more embodiments will now be provided, first with reference to the exemplary flowchart of FIG. 25, and then with reference to FIGS. 26-34.

[0171] In one or more embodiments, an automatic paper towel dispenser apparatus is configured to, after learning how long a paper towel of a paper towel roll is, dispense one or more paper towels via a dispensing opening. Such dispenser apparatus includes a hand wave sensor configured to sense the wave of a user's hand. The dispenser apparatus is configured such that, when a first hand wave is detected at step **1002**, toweling begins to be advanced at step **1004** by providing current to a motor assembly configured to drive the dispensing of toweling.

[0172] As the toweling is advanced, a leading edge of the toweling, i.e. a leading edge of the first paper towel, is detected at step **1006** by a reflective sensor the toweling travels past prior to passing through the dispensing opening. This reflective sensor preferably operates by determining whether emitted light is reflected by toweling, e.g. white toweling.

[0173] Following detection of this leading edge, an extent determined based on a learned length of toweling is advanced at step **1008**. The advancing of exactly this extent is preferably provided via use of a slot sensor. The slot sensor comprises an emitter, a detector disposed opposite the emitter, and a rotatable disc disposed therebetween. The rotatable disc includes a plurality of slots disposed therein. As toweling is advanced, the rotatable disc rotates, and, as the slots and non-slot sections pass between the emitter and receptor, light emitted by the emitter is intermittently received by the receptor. The slot sensor is configured to determine, based on the intermittent reception of light by the receptor, the amount of rotation of the rotatable disc, and thus the amount of toweling advanced. Once, following detection of the leading edge, the desired extent of toweling based on a learned length of toweling has been advanced, current is drawn from the motor assembly to halt dispensing at step **1010**. In at least some embodiments, upon halting of dispensing, a perforated line separating the first paper towel from a next paper towel is disposed at, on, under, and/or proximate to the reflective sensor. In at least some other embodiments, an additional offset is added to or subtracted from a

learned towel length such that such perforated line is disposed upstream of, or downstream of, the reflective sensor.

[0174] Preferably, the dispenser apparatus is further configured such that, following halting of dispensing, a first time period begins at step **1012**. This time period is preferably measured by a timer, and preferably lasts around one second. At any time prior to the end of this time period, a subsequent hand wave will trigger advancement of an additional extent of toweling based on a learned length. Preferably, such a subsequent hand wave will also result in the resetting or restarting of the first time period, thereby providing additional time for yet another hand wave, although, in at least some embodiments, this is not the case. In this way, a user is able to trigger dispensing of any number of paper towels that they wish, via, for example, that number of hand waves, or by continually leaving their hand in front of the hand wave sensor until a desired number of paper towels have been dispensed. In an embodiment, during this first time period, an indicator disposed proximate the hand wave sensor displays a first color, e.g. red.

[0175] Preferably, following expiration of this first time period, a second time period begins. This second time period is preferably also measured by a timer, and preferably lasts around four seconds. During this second time period, hand waving by the user does not trigger the dispensing of any additional paper towels. In an embodiment, during this second time period, an indicator disposed proximate the hand wave sensor displays a second color, e.g. orange.

[0176] This second time period is intended to allow a user to tear off one or more dispensed paper towels. It will be appreciated that, when a user goes to tear off one or more dispensed paper towels, force applied by the user could cause the withdrawal of additional toweling from the dispenser apparatus, barring any mechanism for the prevention of such additional withdrawal. In an embodiment, the slot sensor is utilized in combination with the motor assembly to mitigate, or prevent, any such withdrawal, via the use of a “fight sequence”. Preferably, the slot sensor is utilized to determine whether additional toweling has been withdrawn, via the detection of rotation of the rotatable disc of the slot sensor. In the event of such rotation, current, having an opposite polarity to that described hereinabove (sometimes referred to herein as reverse polarity current), is preferably provided to the motor assembly to return the slot sensor to its prior position (e.g. the position it was in prior to rotation of the slot sensor caused by a user attempting to tear off one or more dispensed paper towels).

[0177] The second time period is represented by step **1016**. Upon expiration of the second time period, the reflective sensor disposed proximate the dispensing opening determines whether or not toweling is sensed at step **1018**. If the reflective sensor senses toweling, then the toweling is retracted by providing reverse polarity current to the motor assembly at step **1020**. The toweling is preferably retracted until the reflective sensor no longer senses toweling.

[0178] Following this, the dispenser apparatus is ready to once again detect a user’s initial hand wave at step **1002**.

[0179] FIGS. 26-34 illustrate an exemplary dispensing sequence for a paper towel dispenser apparatus in accordance with one or more embodiments of the invention.

[0180] FIG. 26 illustrates a paper towel dispenser apparatus. To dispense toweling, a user triggers a hand wave sensor of the dispenser apparatus using their hand, as illustrated in FIG. 27. Upon detecting the user's hand via the hand wave sensor, the dispenser apparatus dispenses a learned towel length. After dispensing the learned towel length, the dispenser apparatus determines whether the user's hand is still present, or if the user has waved his hand again. If so, the dispenser apparatus dispenses an additional learned towel length. In this way, a user can effect dispensing of multiple learned towel lengths by leaving his hand in front of the hand wave sensor, as illustrated in FIGS. 28-29.

[0181] Once the user ceases triggering the hand wave sensor via their hand, then the dispenser apparatus will cease dispensing additional learned towel lengths. Upon this occurring, the dispenser apparatus will begin waiting a tear time interval, thereby allowing the user to tear off one or more sheets of dispensed toweling. FIG. 30 illustrates a user tearing off a single sheet of dispensed toweling after dispensing a plurality of sheets of toweling. Upon expiration of the tear time interval, the sheets that were dispensed, but not torn off by the user, are retracted back into the dispenser apparatus, as illustrated in FIGS. 31-34.

[0182] Based on the foregoing description, it will be readily understood by those persons skilled in the art that the present invention is susceptible of broad utility and application. Many embodiments and adaptations of the present invention other than those specifically described herein, as well as many variations, modifications, and equivalent arrangements, will be apparent from or reasonably suggested herein, without departing from the substance or scope of the present invention.

[0183] Accordingly, while the present invention has been described herein in detail in relation to one or more preferred embodiments, it is to be understood that this disclosure is only illustrative and exemplary of the present invention and is made merely for the purpose of providing a full and enabling disclosure of the invention. The foregoing disclosure is not intended to be construed to limit the present invention or otherwise exclude any such other embodiments, adaptations, variations, modifications or equivalent arrangements, the present invention being limited only by the claims appended hereto and the equivalents thereof.

What is claimed is:

1. A method of dispensing towels from toweling with a dispenser, comprising:
  - (a) using a motor assembly configured to cause a leading edge of the toweling to be extended from a housing of the dispenser and to cause the toweling to be subsequently retracted back into the housing, the step of extending the toweling exterior of the housing for grasping by a user; and subsequent thereto, the steps of,
  - (b) retracting the toweling into the housing using the motor assembly;
  - (c) sensing a leading edge of the toweling, using a sensor, while retracting the toweling; and
  - (d) ceasing retracting of the toweling into the housing using the motor assembly as a function of sensing the leading edge of the toweling using the sensor.
2. The method of claim 1, wherein the housing comprises,
  - (a) a main body, and
  - (b) a loading door that is configured to rotate relative to the main body between,
    - (i) a closed position, in which the housing is configured to extend toweling there from, and
    - (ii) an open position, in which the housing is configured to receive toweling therein,
  - (c) wherein the loading door comprises a towel carrier having a curved surface defining a cavity within which toweling comprising a roll of paper towels is received and retained in floating engagement therewith, the roll of paper towels rolling and sliding on the curved surface when unwinding during said step of extending the toweling exterior of the housing for grasping by a user, and toweling gathering within the housing during retracting of the toweling into the housing and not being wound back onto the roll of paper towels.
3. The method of claim 1,
  - (a) wherein the housing comprises,
    - (i) a main body,
    - (ii) a loading door that is configured to rotate relative to the main body between,
      - (A) a closed position, in which the housing is configured to extend toweling there from, and
      - (B) an open position, in which the housing is configured to receive toweling therein, and
    - (iii) a guide system that is configured to guide the toweling within the housing during extension from and retraction into the housing of the toweling, the guide system comprising a first roller attached to the main body and having a first toothed surface, and a second roller attached to the loading door and

- having a second toothed surface that is configured to mesh with the first toothed surface,
- (iv) wherein at least one end of the first roller moves such that an axis of rotation of the first roller moves relative to the main body of the housing; and
- (b) wherein the method further comprises the step of moving the loading door into the closed position after loading toweling within the dispenser, with the first roller being urged into engagement with the second roller when the loading door enters the closed position and the second roller acting on the first roller so as to displace at least one end of the first roller when the loading door enters the closed position.
4. The method of claim 1, wherein the housing comprises extension walls located proximate opposite exterior sides of the housing that extend above a top side of the housing, and wherein the method further comprises a preliminary step of mounting the dispenser to the underside of a fixture, including removing a portion of each extension wall along a score line so as to adjust the distance from the underside of the fixture below which the top side of the housing is mounted.
5. The method of claim 1,
- (a) wherein the toweling comprises a roll of paper towels and the dispenser is configured to unwind roll of paper towels during extension of toweling from the housing but not rewind the roll of paper towels during subsequent retraction of toweling into the housing, and
- (b) wherein a back side of the housing includes an opening that is configured such that excess toweling gathering within the housing may fall there through as a result of retraction of toweling back into the housing.
6. The method of claim 1, wherein the toweling comprises towels connected together and separable at perforations formed there between, the toweling being a roll of perforated paper towels.
7. The method of claim 6, wherein said step of extending the toweling exterior of the housing for grasping by the user includes extending a sufficient length of the toweling such that at least one line of perforations is located outside of the housing whereby tearing along the line of perforations leaves a residual extent of the toweling extending outside of the housing after tearing.
8. The method of claim 1, wherein said step of extending the toweling exterior of the housing for grasping by the user comprises extending the toweling a predetermined unit length beyond the point at which the sensor detects the leading edge of the toweling.
9. The method of claim 8, wherein said step of extending the toweling exterior of the housing for grasping by the user comprises further extending the toweling an extent that is less than the predetermined unit length such that at least one line of perforations is located outside of

- the housing, whereby tearing along the line of perforations leaves a residual extent of the toweling extending outside of the housing after tearing.
10. The method of claim 8, wherein said step of extending the toweling exterior of the housing for grasping by the user comprises further extending the toweling another predetermined unit length beyond the point at which the sensor detects the leading edge of the toweling.
  11. The method of claim 1, wherein said step of extending the toweling exterior of the housing for grasping by the user comprises extending the toweling a predetermined unit length beyond the point at which the sensor detects the leading edge of the toweling in response to the sensing of a hand proximate the dispenser.
  12. The method of claim 11, wherein said step of extending the toweling exterior of the housing for grasping by the user comprises further extending the toweling an additional extent such that at least one line of perforations is located outside of the housing, whereby tearing along the line of perforations leaves a residual extent of the toweling extending outside of the housing after tearing.
  13. The method of claim 12, wherein the additional extent is less than the predetermined unit length.
  14. The method of claim 11, wherein said step of extending the toweling exterior of the housing for grasping by the user comprises extending the toweling another predetermined unit length in response to the continued sensing of the hand proximate the dispenser.
  15. The method of claim 11, further comprising setting the predetermined unit length, by which the toweling is extended, in a length learn sequence comprising the steps of,
    - (a) retracting the toweling until a leading edge of the toweling is sensed by the sensor;
    - (b) advancing the toweling a preset extended length, the preset extended length being greater than at least a distance between immediately adjacent lines of perforations in the toweling;
    - (c) retracting the toweling until a leading edge of the toweling is sensed by the sensor while measuring a length by which the toweling is retracted; and
    - (d) determining the difference between the preset extended length and the measured retracted length, the difference being the predetermined unit length.
  16. The method of claim 15, wherein the preset extended length is greater than twice the distance between immediately adjacent lines of perforations in the toweling, whereby the predetermined unit length may be set for dispensing up to two towels at a time.
  17. The method of claim 15, wherein the preset extended length is greater than three times the distance between immediately adjacent lines of perforations in the toweling, whereby the predetermined unit length may be set for dispensing up to three towels at a time.

18. The method of claim 15, wherein the preset extended length is greater than four times the distance between immediately adjacent lines of perforations in the toweling, whereby the predetermined unit length may be set for dispensing up to four towels at a time.
19. The method of claim 15, further comprising the step of initiating the length learn sequence of the dispenser by installing a roll of paper towels in the dispenser.
20. The method of claim 15, further comprising the step of initiating the length learn sequence of the dispenser by moving a loading door of the dispenser, through which a roll of paper towels is received, to a closed position.
21. The method of claim 15, further comprising the step of initiating the length learn sequence of the dispenser by moving a loading door of the dispenser, through which a roll of paper towels is received, to a closed position with a length of the toweling draped over and extending from the loading door.
22. The method of claim 1, wherein the motor assembly comprises a motor and a controller configured to control operation of the motor and the subsequent extension of the toweling from and retraction of the toweling into the housing.
23. The method of claim 22, further comprising the step of measuring extension or retraction of the toweling.
24. The method of claim 22, further comprising the step of measuring extension or retraction of the toweling using an encoder pinwheel that rotates during extension and retraction of the toweling.
25. The method of claim 22, further comprising the step of measuring, using an LED component, complementary metal oxide semiconductor (CMOS) component, and digital signal processor (DSP) component, extension or retraction of the toweling by the motor; the step of measuring, using a laser component, complementary metal oxide semiconductor (CMOS) component, and digital signal processor (DSP) component, extension or retraction of the toweling by the motor; or both steps.
26. The method of claim 22, wherein the sensor for detecting the leading edge of the toweling comprises a LED component, complementary metal oxide semiconductor (CMOS) component, and digital signal processor (DSP), and wherein the sensor furthermore performs a step of measuring extension or retraction of the toweling.
27. The method of claim 22, wherein the sensor for detecting the leading edge of the toweling comprises a laser component, complementary metal oxide semiconductor (CMOS) component, and digital signal processor (DSP) component, and wherein the sensor furthermore performs a step of measuring extension or retraction of the toweling.
28. The method of claim 1, wherein a loading door of the dispenser comprises a guiding surface along which toweling rides when retracted into the housing, the guiding surface forming a

- backdrop that is dark and contrasts well with the toweling so as to better define the leading edge of the toweling for sensing by the sensor.
29. A towel dispenser that performs the method for dispensing a towel as disclosed in any of claims 1-28.
30. A towel dispenser, comprising:
- (a) a housing for receiving toweling comprising a roll of paper towels;
  - (b) a motor assembly configured to cause a leading edge of the toweling to be extended from the housing and to cause the toweling to be retracted into the housing after the leading edge has been extended; and
  - (c) a sensor for sensing a leading edge of the toweling during retraction of the toweling by the motor assembly;
  - (d) wherein the sensor is configured to cause the motor assembly to cease retracting the toweling into the housing as a function of the sensing of the leading edge of the toweling during retraction of the toweling into the housing.
31. The towel dispenser of claim 30, wherein the housing comprises,
- (a) a main body,
  - (b) a loading door that is configured to rotate relative to the main body between,
    - (i) a closed position, in which the housing is configured to extend toweling there from, and
    - (ii) an open position, in which the housing is configured to receive toweling therein,
  - (c) wherein the loading door comprises a towel carrier having a curved surface defining a cavity configured to receive the roll of paper towels in floating engagement therewith such that the roll of paper towels rolls and slides on the curved surface during unwinding.
32. The towel dispenser of claim 30, wherein the housing comprises
- (a) a main body,
  - (b) a loading door that is configured to rotate relative to the main body between,
    - (i) a closed position, in which the housing is configured to extend toweling there from, and
    - (ii) an open position, in which the housing is configured to receive toweling therein,
  - (c) a guide system that is configured to guide the toweling within the housing during extension from and retraction into the housing of the toweling, the guide system comprising a first roller attached to the main body and having a first toothed surface, and a second roller attached to the loading door and having a second toothed surface that is configured to mesh with the first toothed surface,

- (d) wherein at least one end of the first roller moves such that an axis of rotation of the first roller moves relative to the main body of the housing,
  - (e) wherein the first roller is spring biased toward engagement with the second roller when the loading door is in the closed position, and
  - (f) wherein the toothed surfaces of the first roller and the second roller mesh together when the loading door moves into the closed position from the open position and do not preclude the loading door from moving into the closed position from the open position.
33. The towel dispenser of claim 30, wherein the housing further comprises extension walls located proximate opposite exterior sides of the housing that extends above a top side of the housing, each extension wall comprising a weakened line extending parallel to a weakened line of the other extension walls, whereby the extent above the top side at which each extension walls extends may be changed, the extent representing a distance from the underside of a fixture below which the top side of the housing is mounted when the towel dispenser is installed under the fixture.
34. The towel dispenser of claim 30, wherein a back side of the housing includes an opening configured to permit excess toweling to fall during retraction of the toweling back into the housing.
35. The towel dispenser of claim 30, wherein the motor assembly comprises a motor and a controller configured to control operation of the motor and the subsequent extension of the toweling from and retraction of the toweling into the housing.
36. The towel dispenser of claim 30, wherein the motor assembly is configured to cause a line of perforations of the toweling to be extended from the housing such that whereby tearing along the line of perforations leaves a residual extent of the toweling extending outside of the housing after tearing.
37. The towel dispenser of claim 36, wherein the motor assembly is further configured to cause the residual extent of the toweling to be retracted into the housing after tearing.
38. The towel dispenser of claim 30, wherein the motor assembly is configured to cause the toweling to be extended a predetermined unit length beyond the point at which the sensor detects the leading edge of the toweling.
39. The towel dispenser of claim 38, wherein the motor assembly is configured to cause the toweling to be further extended an extent that is less than the predetermined unit length such that at least one line of perforations is located outside of the housing, whereby tearing along the line of perforations leaves a residual extent of the toweling extending outside of the housing after tearing.

40. The towel dispenser of claim 39, wherein the motor assembly is configured to cause the toweling to be further extended another predetermined unit length beyond the point at which the sensor detects the leading edge of the toweling.
41. The towel dispenser of claim 30, wherein the motor assembly is configured to cause, in response to the sensing of a hand proximate the dispenser, the toweling to be extended a predetermined unit length beyond the point at which the sensor detects the leading edge of the toweling.
42. The towel dispenser of claim 41, wherein the motor assembly is configured to cause the toweling to be further extended an extent that is less than the predetermined unit length such that at least one line of perforations is located outside of the housing, whereby tearing along the line of perforations leaves a residual extent of the toweling extending outside of the housing after tearing.
43. The towel dispenser of claim 42, wherein the additional extent is less than the predetermined unit length.
44. The towel dispenser of claim 43, wherein the motor assembly is configured to cause the toweling to be further extended another predetermined unit length in response to the continued sensing of the hand proximate the dispenser.
45. The towel dispenser of claim 43, wherein the motor assembly is configured such that the predetermined unit length, by which the toweling is extended, is set in a length learn sequence that comprises the steps of,
  - (a) retracting the toweling until a leading edge of the toweling is sensed by the sensor;
  - (b) advancing the toweling a preset extended length, the preset extended length being greater than at least a distance between immediately adjacent lines of perforations in the toweling;
  - (c) retracting the toweling until a leading edge of the toweling is sensed by the sensor while measuring a length by which the toweling is retracted; and
  - (d) determining the difference between the preset extended length and the measured retracted length, the difference being the predetermined unit length.
46. The towel dispenser of claim 45, wherein the preset extended length is greater than twice the distance between immediately adjacent lines of perforations in the toweling, whereby the predetermined unit length may be set for dispensing up to two towels at a time.
47. The towel dispenser of claim 45, wherein the preset extended length is greater than three times the distance between immediately adjacent lines of perforations in the toweling, whereby the predetermined unit length may be set for dispensing up to three towels at a time.
48. The towel dispenser of claim 45, wherein the preset extended length is greater than four times the distance between immediately adjacent lines of perforations in the toweling, whereby the predetermined unit length may be set for dispensing up to four towels at a time.

49. The towel dispenser of claim 45, wherein the motor assembly is configured to enter the length learn sequence when a roll of paper towels is installed in the dispenser.
50. The towel dispenser of claim 45, wherein the motor assembly is configured to enter the length learn sequence when a loading door of the dispenser, through which a roll of paper towels is received, is moved to a closed position for dispensing of towels.
51. The towel dispenser of claim 45, wherein the motor assembly is configured to enter the length learn sequence when a loading door of the dispenser, through which a roll of paper towels is received, is moved to a closed position for dispensing of towels, with a length of the toweling draped over and extending from the loading door.
52. The towel dispenser of claim 45, wherein the motor assembly comprises a motor and a controller configured to control operation of the motor and the subsequent extension of the toweling from, and retraction of the toweling into, the housing.
53. The towel dispenser of claim 52, further comprising an encoder configured to measure extension and retraction of the toweling.
54. The towel dispenser of claim 53, wherein the encoder comprises an encoder pinwheel.
55. The towel dispenser of claim 52, further comprising an optical sensor assembly configured to measure extension and retraction of the toweling by the motor, the optical sensor assembly comprising an LED component, complementary metal oxide semiconductor (CMOS) component, and digital signal processor (DSP) component.
56. The towel dispenser of claim 55, wherein the sensor for detecting the leading edge of the toweling comprises the optical sensor assembly.
57. The towel dispenser of claim 52, further comprising an optical sensor assembly configured to measure extension and retraction of the toweling by the motor, the optical sensor assembly comprising a laser component, complementary metal oxide semiconductor (CMOS) component, and digital signal processor (DSP) component.
58. The towel dispenser of claim 57, wherein the sensor for detecting the leading edge of the toweling comprises the laser component, complementary metal oxide semiconductor (CMOS) component, and digital signal processor (DSP) component.
59. The towel dispenser of claim 30, wherein a loading door of the dispenser comprises a guiding surface along which toweling rides when retracted into the housing, the guiding surface forming a backdrop that is dark and contrasts well with the toweling so as to better define the leading edge of the toweling for sensing by the sensor.
60. The towel dispenser of claim 30, wherein the loading door further comprises a guiding surface along which toweling rides when being extended from or retracted into the housing.
61. The towel dispenser of claim 60, wherein the guiding surface forms a backdrop to the toweling that is dark and contrasts well so as to better define the leading edge of the toweling for sensing by the sensor.

62. The towel dispenser of claim 30, further comprising a sensor for detecting movement of the loading door out of the closed position.
63. A method for dispensing towels by the towel dispenser as disclosed in any of claims 30-62.
64. A method of dispensing towels from toweling with a dispenser, comprising:
- (a) the step of extending the toweling exterior of the housing for grasping by a user; and subsequent thereto,
  - (b) the step of retracting the toweling into the housing;
  - (c) wherein the housing comprises,
    - (i) a main body, and
    - (ii) a loading door that is configured to rotate relative to the main body between,
      - (A) a closed position, in which the housing is configured to extend toweling there from, and
      - (B) an open position, in which the housing is configured to receive toweling therein,
    - (iii) wherein the loading door comprises a towel carrier having a curved surface defining a cavity within which toweling comprising a roll of paper towels is received and retained in floating engagement therewith; and
  - (d) wherein the roll of paper towels rolls and slides on the curved surface when unwinding during said step of extending the toweling exterior of the housing for grasping by a user.
65. The method of claim 64, wherein the toweling gathers within the housing during said step of retracting the toweling into the housing, the toweling not being wound back onto the roll of paper towels.
66. The method of claim 64,
- (a) wherein the housing further comprises a guide system that is configured to guide the toweling within the housing during extension from and retraction into the housing of the toweling, the guide system comprising a first roller attached to the main body and having a first toothed surface, and a second roller attached to the loading door and having a second toothed surface that is configured to mesh with the first toothed surface;
  - (b) wherein at least one end of the first roller moves such that an axis of rotation of the first roller moves relative to the main body of the housing; and
  - (c) wherein the method further comprises the step of moving the loading door into the closed position after loading toweling within the dispenser, with the first roller being urged into engagement with the second roller when the loading door enters the closed position and the second roller acting on the first roller so as to displace at least one end of the first roller when the loading door enters the closed position.

67. The method of claim 66, wherein the dispenser further comprises a motor assembly configured to cause a leading edge of the toweling to be extended from a housing of the dispenser and to cause the toweling to be subsequently retracted back into the housing, both of the steps of extending the toweling exterior of the housing for grasping by a user and the step of retracting the toweling into the housing being accomplished using the motor assembly; and the method further comprising the steps of sensing a leading edge of the toweling while retracting the toweling into the housing, and ceasing retracting of the toweling into the housing as a function of sensing the leading edge of the toweling.
68. The method of claim 64, wherein the housing comprises extension walls located proximate opposite exterior sides of the housing that extend above a top side of the housing, and wherein the method further comprises a preliminary step of mounting the dispenser to the underside of a fixture, including removing a portion of each extension wall along a score line so as to adjust the distance from the underside of the fixture below which the top side of the housing is mounted.
69. The method of claim 68, wherein the dispenser further comprises a motor assembly configured to cause a leading edge of the toweling to be extended from a housing of the dispenser and to cause the toweling to be subsequently retracted back into the housing, both of the steps of extending the toweling exterior of the housing for grasping by a user and the step of retracting the toweling into the housing being accomplished using the motor assembly; and the method further comprising the steps of sensing a leading edge of the toweling while retracting the toweling into the housing, and ceasing retracting of the toweling into the housing as a function of sensing the leading edge of the toweling.
70. The method of claim 64,
- (a) wherein the toweling comprises a roll of paper towels and the dispenser is configured to unwind roll of paper towels during extension of toweling from the housing but not rewind the roll of paper towels during subsequent retraction of toweling into the housing, and
  - (b) wherein a back side of the housing includes an opening that is configured such that excess toweling gathering within the housing may fall as a result of retraction of toweling back into the housing.
71. The method of claim 70, wherein the dispenser further comprises a motor assembly configured to cause a leading edge of the toweling to be extended from a housing of the dispenser and to cause the toweling to be subsequently retracted back into the housing, both of the steps of extending the toweling exterior of the housing for grasping by a user and the step of retracting the toweling into the housing being accomplished using the motor assembly; and the method further comprising the steps of sensing a leading edge of the toweling while

retracting the toweling into the housing, and ceasing retracting of the toweling into the housing as a function of sensing the leading edge of the toweling.

72. A towel dispenser, comprising:

- (a) a housing for receiving toweling, comprising
  - (i) a main body,
  - (ii) a loading door that is configured to rotate relative to the main body between,
    - (A) a closed position, in which the housing is configured to dispense towels there from, and
    - (B) an open position, in which the housing is configured to receive toweling therein, and
  - (iii) a guide system that is configured to guide the toweling within the housing while towels are dispensed from the housing;
- (b) wherein the loading door comprises a towel carrier having a curved surface defining a cavity configured to receive the roll of paper towels in floating engagement therewith such that the roll of paper towels rolls and slides on the curved surface during unwinding.

73. The towel dispenser of claim 72, wherein the housing further comprises,

- (a) a guide system that is configured to guide the toweling within the housing during extension from and retraction into the housing of the toweling, the guide system comprising a first roller attached to the main body and having a first toothed surface, and a second roller attached to the loading door and having a second toothed surface that is configured to mesh with the first toothed surface,
- (b) wherein at least one end of the first roller moves such that an axis of rotation of the first roller moves relative to the main body of the housing,
- (c) wherein the first roller is spring biased toward engagement with the second roller when the loading door is in the closed position, and
- (d) wherein the toothed surfaces of the first roller and the second roller mesh together when the loading door moves into the closed position from the open position and do not preclude the loading door from moving into the closed position from the open position.

74. The towel dispenser of claim 73, wherein the housing further comprises:

- (a) a motor assembly configured to cause a leading edge of the toweling to be extended from the housing and to cause the toweling to be retracted into the housing after the leading edge has been extended; and
- (b) a sensor for sensing a leading edge of the toweling during retraction of the toweling by the motor assembly;

- (c) wherein the sensor is configured to cause the motor assembly to cease retracting the toweling into the housing as a function of the sensing of the leading edge of the toweling during retraction of the toweling into the housing.
- 75. The towel dispenser of claim 72, wherein the housing further comprises extension walls located proximate opposite exterior sides of the housing that extends above a top side of the housing, each extension wall comprising a weakened line extending parallel to a weakened line of the other extension walls, whereby the extent above the top side at which each extension walls extends may be changed, the extent representing a distance from the underside of a fixture below which the top side of the housing is mounted when the towel dispenser is installed under the fixture.
- 76. The towel dispenser of claim 75, wherein the housing further comprises:
  - (a) a motor assembly configured to cause a leading edge of the toweling to be extended from the housing and to cause the toweling to be retracted into the housing after the leading edge has been extended; and
  - (b) a sensor for sensing a leading edge of the toweling during retraction of the toweling by the motor assembly;
  - (c) wherein the sensor is configured to cause the motor assembly to cease retracting the toweling into the housing as a function of the sensing of the leading edge of the toweling during retraction of the toweling into the housing.
- 77. The towel dispenser of claim 72, wherein a back side of the housing includes an opening configured to permit excess toweling to fall during retraction of the toweling back into the housing.
- 78. The towel dispenser of claim 77, wherein the housing further comprises:
  - (a) a motor assembly configured to cause a leading edge of the toweling to be extended from the housing and to cause the toweling to be retracted into the housing after the leading edge has been extended; and
  - (b) a sensor for sensing a leading edge of the toweling during retraction of the toweling by the motor assembly;
  - (c) wherein the sensor is configured to cause the motor assembly to cease retracting the toweling into the housing as a function of the sensing of the leading edge of the toweling during retraction of the toweling into the housing.
- 79. The towel dispenser of claim 64, wherein the guide system comprises a first roller attached to the main body and a second roller attached to the loading door.
- 80. The towel dispenser of claim 79, wherein the second roller is the only roller of the guide system affixed to the loading door.
- 81. The towel dispenser of claim 79, wherein the second roller comprises a lower drive roller of the guide system, and the first roller comprises an upper drive roller of the guide system, the

- lower drive roller engaging the upper drive roller with toweling extending there between when the loading door is moved into the closed position with toweling draped over the loading door.
82. The towel dispenser of claim 79, wherein the loading door has a second curved surface that defines a second cavity within which the second roller is retained.
83. The towel dispenser of claim 82, wherein the loading door comprises,
- (i) a first component, a surface of which comprises the curved surface defining the cavity within which the roll of paper towels is received and retained, and
  - (ii) a second component, a surface of which comprises the second curved surface defining the second cavity within which the second roller is retained,
  - (iii) wherein the second component is affixed to the first component.
84. The towel dispenser of claim 83, wherein the second component further defines a guiding surface along which toweling rides when extended from the housing.
85. The towel dispenser of claim 64, further comprising a sensor mounted to the main body and configured to sense a leading edge of the toweling between a gap formed by the main body and the loading door when the loading door is in the closed position.
86. The towel dispenser of claim 85, wherein the loading door comprises a guiding surface that provides a backdrop to toweling, the sensor sensing the leading edge of the toweling against the backdrop of the guiding surface of the loading door.
87. The towel dispenser of claim 85, wherein the sensor comprises a sensor array.
88. The towel dispenser of claim 85, wherein the guide system comprises a first roller attached to the main body and a second roller attached to the loading door.
89. The towel dispenser of claim 88, wherein the second roller is the only roller of the guide system on the loading door.
90. The towel dispenser of claim 88, wherein the loading door having a second curved surface defining a second cavity within which the second roller is received and retained.
91. The towel dispenser of claim 88, wherein the loading door comprises,
- (i) a first component, a surface of which comprises the curved surface defining the cavity within which the roll of paper towels is received and retained, and
  - (ii) a second component, a surface of which comprises the second curved surface defining the second cavity within which the second roller is received and retained,
  - (iii) wherein the second component is affixed to the first component.
92. The towel dispenser of claim 91, wherein the second component further defines a guiding surface against which toweling rides when extended from the housing.
93. A method of dispensing towels from toweling with a dispenser, comprising:
- (a) extending the toweling exterior of the housing for grasping by a user; and subsequent thereto,

- (b) retracting the toweling into the housing;
  - (c) wherein the housing comprises,
    - (i) a main body,
    - (ii) a loading door that is configured to rotate relative to the main body between,
      - (A) a closed position, in which the housing is configured to extend toweling there from, and
      - (B) an open position, in which the housing is configured to receive toweling therein, and
    - (iii) a guide system that is configured to guide the toweling within the housing during extension from and retraction into the housing of the toweling, the guide system comprising a first roller attached to the main body and having a first toothed surface, and a second roller attached to the loading door and having a second toothed surface that is configured to mesh with the first toothed surface,
    - (iv) wherein at least one end of the first roller moves such that an axis of rotation of the first roller moves relative to the main body of the housing; and
  - (d) wherein the method further comprises the step of moving the loading door into the closed position after loading toweling within the dispenser, with the first roller being urged into engagement with the second roller when the loading door enters the closed position and the second roller acting on the first roller so as to displace at least one end of the first roller when the loading door enters the closed position.
94. The method of claim 93, wherein the housing comprises extension walls located proximate opposite exterior sides of the housing that extend above a top side of the housing, and wherein the method further comprises a preliminary step of mounting the dispenser to the underside of a fixture, including removing a portion of each extension wall along a score line so as to adjust the distance from the underside of the fixture below which the top side of the housing is mounted.
95. The method of claim 94, wherein the dispenser further comprises a motor assembly configured to cause a leading edge of the toweling to be extended from a housing of the dispenser and to cause the toweling to be subsequently retracted back into the housing, both of the steps of extending the toweling exterior of the housing for grasping by a user and the step of retracting the toweling into the housing being accomplished using the motor assembly; and the method further comprising the steps of sensing a leading edge of the toweling while retracting the toweling into the housing, and ceasing retracting of the toweling into the housing as a function of sensing the leading edge of the toweling.
96. The method of claim 94, wherein the loading door comprises a towel carrier having a curved surface defining a cavity within which toweling comprising a roll of paper towels is received

- and retained in floating engagement therewith, the roll of paper towels rolling and sliding on the curved surface when unwinding during said step of extending the toweling exterior of the housing for grasping by a user, and toweling gathering within the housing during retracting of the toweling into the housing and not being wound back onto the roll of paper towels
97. The method of claim 93,
- (a) wherein the toweling comprises a roll of paper towels and the dispenser is configured to unwind roll of paper towels during extension of toweling from the housing but not rewind the roll of paper towels during subsequent retraction of toweling into the housing, and
  - (b) wherein a back side of the housing includes an opening that is configured such that excess toweling gathering within the housing may fall as a result of retraction of toweling back into the housing.
98. The method of claim 97, wherein the dispenser further comprises a motor assembly configured to cause a leading edge of the toweling to be extended from a housing of the dispenser and to cause the toweling to be subsequently retracted back into the housing, both of the steps of extending the toweling exterior of the housing for grasping by a user and the step of retracting the toweling into the housing being accomplished using the motor assembly; and the method further comprising the steps of sensing a leading edge of the toweling while retracting the toweling into the housing, and ceasing retracting of the toweling into the housing as a function of sensing the leading edge of the toweling.
99. The method of claim 97, wherein the loading door comprises a towel carrier having a curved surface defining a cavity within which toweling comprising a roll of paper towels is received and retained in floating engagement therewith, the roll of paper towels rolling and sliding on the curved surface when unwinding during said step of extending the toweling exterior of the housing for grasping by a user, and toweling gathering within the housing during retracting of the toweling into the housing and not being wound back onto the roll of paper towels.
100. A towel dispenser, comprising:
- (a) a housing for receiving toweling, comprising
    - (i) a main body,
    - (ii) a loading door that is configured to rotate relative to the main body between,
      - (A) a closed position, in which the housing is configured to dispense towels there from, and
      - (B) an open position, in which the housing is configured to receive toweling therein, and
    - (iii) a guide system that is configured to guide the toweling within the housing while towels are dispensed from the housing;

- (b) wherein the guide system comprises a first roller attached to the main body and having a first toothed surface, and a second roller attached to the loading door and having a second toothed surface that is configured to mesh with the first toothed surface; and
  - (c) wherein the toothed surfaces of the first roller and the second roller mesh together when the loading door moves into the closed position from the open position and do not preclude the loading door from moving into the closed position from the open position.
101. The towel dispenser of claim 100, wherein the housing further comprises extension walls located proximate opposite exterior sides of the housing that extends above a top side of the housing, each extension wall comprising a weakened line extending parallel to a weakened line of the other extension walls, whereby the extent above the top side at which each extension walls extends may be changed, the extent representing a distance from the underside of a fixture below which the top side of the housing is mounted when the towel dispenser is installed under the fixture.
102. The towel dispenser of claim 101, wherein the housing further comprises a motor assembly configured to cause a leading edge of the toweling to be extended from the housing and to cause the toweling to be retracted into the housing after the leading edge has been extended; and a sensor for sensing a leading edge of the toweling during retraction of the toweling by the motor assembly; wherein the sensor is configured to cause the motor assembly to cease retracting the toweling into the housing as a function of the sensing of the leading edge of the toweling during retraction of the toweling into the housing.
103. The towel dispenser of claim 101, wherein the loading door comprises a towel carrier having a curved surface defining a cavity configured to receive the roll of paper towels in floating engagement therewith such that the roll of paper towels rolls and slides on the curved surface during unwinding.
104. The towel dispenser of claim 100, wherein a back side of the housing includes an opening configured to permit excess toweling to fall during retraction of the toweling back into the housing.
105. The towel dispenser of claim 104, wherein the housing further comprises a motor assembly configured to cause a leading edge of the toweling to be extended from the housing and to cause the toweling to be retracted into the housing after the leading edge has been extended; and a sensor for sensing a leading edge of the toweling during retraction of the toweling by the motor assembly; wherein the sensor is configured to cause the motor assembly to cease retracting the toweling into the housing as a function of the sensing of the leading edge of the toweling during retraction of the toweling into the housing.

106. The towel dispenser of claim 104, wherein the loading door comprises a towel carrier having a curved surface defining a cavity configured to receive the roll of paper towels in floating engagement therewith such that the roll of paper towels rolls and slides on the curved surface during unwinding.
107. The towel dispenser of claim 100, wherein each toothed surfaces has a fairly large and forgiving tooth geometry.
108. The towel dispenser of claim 100, wherein the first roller engages the second roller when the loading door is in the closed position.
109. The towel dispenser of claim 100, wherein an axis of rotation of the first roller is located above and forward of an axis of rotation of the second roller when the loading door is in the closed position.
110. The towel dispenser of claim 100, wherein the first roller extends generally alongside a compartment of the housing in which a battery is received, the compartment being accessible through a removable front cover of the housing for changing the battery.
111. The towel dispenser of claim 100, wherein each toothed surface comprises an axially mounted end gear.
112. The towel dispenser of claim 100, wherein the first toothed surfaces is located proximate a first end of the first roller, and wherein the second toothed surface is located proximate a first end of the second roller, the respective first ends of the first and second rollers being located proximate one another when the loading door is in the closed position.
113. The towel dispenser of claim 100, wherein a transmission connects a motor to a second end of the first roller, the second end of the first roller being opposite to the first end of the first roller.
114. The towel dispenser of claim 107, wherein the first end of the first roller is configured to move vertically a small extent, but the second end of the first roller is not configured to move vertically a small extent.
115. The towel dispenser of claim 107, wherein the toothed surface of the first roller is spring biased into meshing engagement with the toothed surface of the second roller when the loading door moves into the closed position from the open position.
116. The towel dispenser of claim 107, wherein the second end of the first roller comprises a pivot point of the first roller.
117. The towel dispenser of claim 107, wherein the first end of the first roller floats relative to the main body, but the second end of the first roller is fixed relative to the main body.
118. The towel dispenser of claim 117, wherein the toothed surface of the first roller is spring biased into meshing engagement with the toothed surface of the second roller when the loading door moves into the closed position from the open position.

119. The towel dispenser of claim 117, wherein the second end of the first roller comprises a pivot point of the first roller.
120. The towel dispenser of claim 100, wherein a belt engages the second end of the first roller for driving of the first roller by the motor.
121. The towel dispenser of claim 100, wherein the toothed surface of the first roller is spring biased into meshing engagement with the toothed surface of the second roller when the loading door moves into the closed position from the open position.
122. The towel dispenser of claim 100, wherein the only rollers of the guide system are the first and second rollers.
123. A towel dispenser, comprising:
  - (a) a housing for receiving toweling, comprising
    - (i) a main body,
    - (ii) a loading door that is configured to rotate relative to the main body between,
      - (A) a closed position, in which the housing is configured to dispense towels there from, and
      - (B) an open position, in which the housing is configured to receive toweling therein, and
    - (iii) a guide system that is configured to guide the toweling within the housing while towels are dispensed from the housing;
  - (b) wherein the guide system comprising a first roller attached to the main body and having a toothed surface proximate a first end thereof, and a second roller attached to the loading door and having a toothed surface proximate a first end thereof that is configured to mesh with the toothed surface of the first roller; and
  - (c) wherein a transmission connects a motor to a second end of the first roller, the second end of the first roller being opposite the first end of the first roller.
124. The towel dispenser of claim 123, wherein the motor is located within the main body between the first roller and a front panel of the housing.
125. The towel dispenser of claim 123, wherein the housing further comprises a battery compartment and wherein the motor is battery powered, the battery compartment and motor being located within the main body between the first roller and a front panel of the housing.
126. The towel dispenser of claim 123, wherein the first end of the first roller is configured to move vertically by a small extent, but the second end of the first roller is not configured to move vertically by a small extent.
127. The towel dispenser of claim 126, wherein the toothed surface of the first roller is spring biased into meshing engagement with the toothed surface of the second roller when the loading door is in the closed position.

128. The towel dispenser of claim 126, wherein the second end of the first roller comprises a pivot point of the first roller.
129. The towel dispenser of claim 123, wherein the first end of the first roller floats relative to the main body, but the second end of the first roller is fixed relative to the main body.
130. The towel dispenser of claim 123, wherein the toothed surface of the first roller is spring biased into meshing engagement with the toothed surface of the second roller when the loading door moves into the closed position from the open position.
131. The towel dispenser of claim 129, wherein the second end of the first roller comprises a pivot point of the first roller.
132. The towel dispenser of claim 123, wherein a belt engages the first roller proximate a second end thereof for driving of the first roller by the motor.
133. The towel dispenser of claim 123, wherein the toothed surface of the first roller is spring biased into meshing engagement with the toothed surface of the second roller when the loading door is in the closed position.
134. The towel dispenser of claim 123, wherein the only rollers of the guide system are the first and second rollers.
135. A towel dispenser, comprising:
  - (a) a housing for receiving toweling, comprising
    - (i) a main body,
    - (ii) a loading door that is configured to rotate relative to the main body between,
      - (A) a closed position, in which the housing is configured to dispense towels there from, and
      - (B) an open position, in which the housing is configured to receive toweling therein, and
    - (iii) a guide system that is configured to guide the toweling within the housing while towels are dispensed from the housing;
  - (b) wherein the guide system comprising a first roller attached to the main body and having a first toothed surface, and a second roller attached to the loading door and having a second toothed surface that is configured to mesh with the first toothed surface; and
  - (c) wherein the first roller is spring biased toward engagement with the second roller when the loading door is in the closed position.
136. The towel dispenser of claim 135, wherein a transmission connects a motor to a second end of the first roller, the second end of the first roller being opposite to the first end of the first roller.

137. The towel dispenser of claim 136, wherein the first end of the first roller is configured to move vertically a small extent, but the second end of the first roller is not configured to move vertically a small extent.
138. The towel dispenser of claim 137, wherein the second end of the first roller comprises a pivot point of the first roller.
139. The towel dispenser of claim 136, wherein the first end of the first roller floats relative to the main body, but the second end of the first roller is fixed relative to the main body.
140. The towel dispenser of claim 139, wherein the second end of the first roller comprises a pivot point of the first roller.
141. The towel dispenser of claim 135, wherein a belt engages the second end of the first roller for driving of the first roller by the motor.
142. The towel dispenser of claim 135, wherein the only rollers of the guide system are the first and second rollers.
143. The towel dispenser of claim 135, wherein the second roller acts against the spring biasing of the first roller to displace at least one end of the first roller when the loading door is moved into the closed position.
144. A method of dispensing towels from toweling with a dispenser, comprising:
  - (a) extending the toweling exterior of a housing of the dispenser for grasping by a user; and subsequent thereto,
  - (b) retracting the toweling into the housing;
  - (c) wherein the housing comprises extension walls located proximate opposite exterior sides of the housing that extend above a top side of the housing, and
  - (d) wherein the method further comprises a preliminary step of mounting the dispenser to the underside of a fixture, including removing a portion of each extension wall along a score line so as to adjust the distance from the underside of the fixture below which the top side of the housing is mounted.
145. The method of claim 144,
  - (a) wherein the toweling comprises a roll of paper towels and the dispenser is configured to unwind roll of paper towels during extension of toweling from the housing but not rewind the roll of paper towels during subsequent retraction of toweling into the housing, and
  - (b) wherein a back side of the housing includes an opening that is configured such that excess toweling gathering within the housing may fall as a result of retraction of toweling back into the housing.
146. The method of claim 145, comprising:

- (a) using a motor assembly configured to cause a leading edge of the toweling to be extended from a housing of the dispenser and to cause the toweling to be subsequently retracted back into the housing in said steps of the method;
  - (b) sensing a leading edge of the toweling while retracting the toweling; and
  - (c) ceasing retracting of the toweling into the housing using the motor assembly as a function of sensing the leading edge of the toweling by the sensor.
147. The method of claim 145, wherein the housing comprises,
- (a) a main body, and
  - (b) a loading door that is configured to rotate relative to the main body between,
    - (i) a closed position, in which the housing is configured to extend toweling there from, and
    - (ii) an open position, in which the housing is configured to receive toweling therein,
  - (c) wherein the loading door comprises a towel carrier having a curved surface defining a cavity within which toweling comprising a roll of paper towels is received and retained in floating engagement therewith, the roll of paper towels rolling and sliding on the curved surface when unwinding during said step of extending the toweling exterior of the housing for grasping by a user, and toweling gathering within the housing during retracting of the toweling into the housing and not being wound back onto the roll of paper towels.
148. The method of claim 145,
- (a) wherein the housing comprises,
    - (i) a main body,
    - (ii) a loading door that is configured to rotate relative to the main body between,
      - (A) a closed position, in which the housing is configured to extend toweling there from, and
      - (B) an open position, in which the housing is configured to receive toweling therein, and
    - (iii) a guide system that is configured to guide the toweling within the housing during extension from and retraction into the housing of the toweling, the guide system comprising a first roller attached to the main body and having a first toothed surface, and a second roller attached to the loading door and having a second toothed surface that is configured to mesh with the first toothed surface,
    - (iv) wherein at least one end of the first roller moves such that an axis of rotation of the first roller moves relative to the main body of the housing; and

- (b) wherein the method further comprises the step of moving the loading door into the closed position after loading toweling within the dispenser, with the first roller being urged into engagement with the second roller when the loading door enters the closed position and the second roller acting on the first roller so as to displace at least one end of the first roller when the loading door enters the closed position.
149. The method of claim 144, wherein each extension wall is integral with the main body of the housing.
150. The method of claim 144, wherein each extension wall is integrally formed with the main body of the housing.
151. The method of claim 144, wherein each extension wall extends opposite side walls of the housing beyond the top side of the housing.
152. The method of claim 144, wherein each extension wall is configured to be broken off by hand upon bending along a weakened line of the extension wall.
153. The method of claim 144, wherein each extension wall includes a plurality of weakened lines.
154. The method of claim 144, wherein each weakened line of an extension wall extends in parallel to, and at the same height from the top side of the housing, as a corresponding weakened line of the other extension wall.
155. A towel dispenser, comprising a housing for receiving toweling comprising a roll of paper towels, the housing comprising extension walls located proximate opposite exterior sides of the housing that extends above a top side of the housing, each extension wall comprising a weakened line extending parallel to a weakened line of the other extension walls, whereby the extent above the top side at which each extension walls extends may be changed, the extent representing a distance from the underside of a fixture below which the top side of the housing is mounted when the towel dispenser is installed under the fixture.
156. The towel dispenser of claim 155, wherein a back side of the housing includes an opening configured to permit excess toweling to fall there through during retraction of the toweling into the housing.
157. The towel dispenser of claim 156, wherein the housing further comprises:
- (a) a motor assembly configured to cause a leading edge of the toweling to be extended from the housing and to cause the toweling to be retracted into the housing after the leading edge has been extended; and
  - (b) a sensor for sensing a leading edge of the toweling during retraction of the toweling by the motor assembly;
  - (c) wherein the sensor is configured to cause the motor assembly to cease retracting the toweling into the housing as a function of the sensing of the leading edge of the toweling during retraction of the toweling into the housing.
158. The towel dispenser of claim 156, wherein the housing comprises,

- (a) a main body,
  - (b) a loading door that is configured to rotate relative to the main body between,
    - (i) a closed position, in which the housing is configured to extend toweling there from, and
    - (ii) an open position, in which the housing is configured to receive toweling therein,
  - (c) wherein the loading door comprises a towel carrier having a curved surface defining a cavity configured to receive the roll of paper towels in floating engagement therewith such that the roll of paper towels rolls and slides on the curved surface during unwinding.
159. The towel dispenser of claim 156, wherein the housing comprises
- (a) a main body,
  - (b) a loading door that is configured to rotate relative to the main body between,
    - (i) a closed position, in which the housing is configured to extend toweling there from, and
    - (ii) an open position, in which the housing is configured to receive toweling therein,
  - (c) a guide system that is configured to guide the toweling within the housing during extension from and retraction into the housing of the toweling, the guide system comprising a first roller attached to the main body and having a first toothed surface, and a second roller attached to the loading door and having a second toothed surface that is configured to mesh with the first toothed surface,
  - (d) wherein at least one end of the first roller moves such that an axis of rotation of the first roller moves relative to the main body of the housing,
  - (e) wherein the first roller is spring biased toward engagement with the second roller when the loading door is in the closed position, and
  - (f) wherein the toothed surfaces of the first roller and the second roller mesh together when the loading door moves into the closed position from the open position and do not preclude the loading door from moving into the closed position from the open position.
160. A method of dispensing towels from toweling with a dispenser, comprising:
- (a) extending the toweling exterior of a housing of the dispenser for grasping by a user; and subsequent thereto,
  - (b) retracting the toweling into the housing;
  - (c) wherein the toweling comprises a roll of paper towels and the dispenser is configured to unwind roll of paper towels during extension of toweling from the housing but not

rewind the roll of paper towels during subsequent retraction of toweling into the housing, and

- (d) wherein a back side of the housing includes an opening that is configured such that excess toweling gathering within the housing may fall as a result of retraction of toweling back into the housing.

161. The method of claim 160, comprising:

- (a) using a motor assembly configured to cause a leading edge of the toweling to be extended from a housing of the dispenser and to cause the toweling to be subsequently retracted back into the housing, performing said steps of extending the toweling exterior of the housing for grasping by a user and subsequent thereto, retracting the toweling into the housing;
- (b) using a sensor for sensing a leading edge of the toweling, sensing a leading edge of the toweling while retracting the toweling;
- (c) ceasing retracting of the toweling into the housing using the motor assembly as a function of sensing the leading edge of the toweling by the sensor;
- (d) wherein the housing comprises,
  - (i) a main body, and
  - (ii) a loading door that is configured to rotate relative to the main body between,
    - (A) a closed position, in which the housing is configured to extend toweling there from, and
    - (B) an open position, in which the housing is configured to receive toweling therein,
  - (iii) a guide system that is configured to guide the toweling within the housing during extension from and retraction into the housing of the toweling, the guide system comprising a first roller attached to the main body and having a first toothed surface, and a second roller attached to the loading door and having a second toothed surface that is configured to mesh with the first toothed surface, at least one end of the first roller being configured to move such that an axis of rotation of the first roller moves relative to the main body of the housing;
- (e) wherein the loading door comprises a towel carrier having a curved surface defining a cavity within which toweling comprising a roll of paper towels is received and retained in floating engagement therewith, the roll of paper towels rolling and sliding on the curved surface when unwinding during said step of extending the toweling exterior of the housing for grasping by a user, and toweling gathering within the housing during retracting of the toweling into the housing and not being wound back onto the roll of paper towels; and

- (f) wherein the method further comprises the step of moving the loading door into the closed position after loading toweling within the dispenser, with the first roller being urged into engagement with the second roller when the loading door enters the closed position and the second roller acting on the first roller so as to displace at least one end of the first roller when the loading door enters the closed position.
162. The method of claim 160, comprising:
- (a) using a motor assembly configured to cause a leading edge of the toweling to be extended from a housing of the dispenser and to cause the toweling to be subsequently retracted back into the housing, performing said steps of extending the toweling exterior of the housing for grasping by a user and subsequent thereto, retracting the toweling into the housing;
  - (b) using a sensor for sensing a leading edge of the toweling, sensing a leading edge of the toweling while retracting the toweling;
  - (c) ceasing retracting of the toweling into the housing using the motor assembly as a function of sensing the leading edge of the toweling by the sensor;
  - (d) wherein the housing comprises,
    - (a) a main body, and
    - (b) a loading door that is configured to rotate relative to the main body between,
      - (i) a closed position, in which the housing is configured to extend toweling there from, and
      - (ii) an open position, in which the housing is configured to receive toweling therein;
  - (e) wherein the loading door comprises a towel carrier having a curved surface defining a cavity within which toweling comprising a roll of paper towels is received and retained in floating engagement therewith, the roll of paper towels rolling and sliding on the curved surface when unwinding during said step of extending the toweling exterior of the housing for grasping by a user, and toweling gathering within the housing during retracting of the toweling into the housing and not being wound back onto the roll of paper towels; and
  - (f) wherein the housing comprises extension walls located proximate opposite exterior sides of the housing that extend above a top side of the housing, and wherein the method further comprises a preliminary step of mounting the dispenser to the underside of a fixture, including removing a portion of each extension wall along a score line so as to adjust the distance from the underside of the fixture below which the top side of the housing is mounted.
163. The method of claim 160, wherein the housing comprises,
- (a) a main body, and

- (b) a loading door that is configured to rotate relative to the main body between,
    - (i) a closed position, in which the housing is configured to extend toweling therefrom, and
    - (ii) an open position, in which the housing is configured to receive toweling therein,
    - (iii) a guide system that is configured to guide the toweling within the housing during extension from and retraction into the housing of the toweling, the guide system comprising a first roller attached to the main body and having a first toothed surface, and a second roller attached to the loading door and having a second toothed surface that is configured to mesh with the first toothed surface, at least one end of the first roller being configured to move such that an axis of rotation of the first roller moves relative to the main body of the housing;
  - (c) wherein the loading door comprises a towel carrier having a curved surface defining a cavity within which toweling comprising a roll of paper towels is received and retained in floating engagement therewith, the roll of paper towels rolling and sliding on the curved surface when unwinding during said step of extending the toweling exterior of the housing for grasping by a user, and toweling gathering within the housing during retracting of the toweling into the housing and not being wound back onto the roll of paper towels;
  - (d) wherein the method further comprises the step of moving the loading door into the closed position after loading toweling within the dispenser, with the first roller being urged into engagement with the second roller when the loading door enters the closed position and the second roller acting on the first roller so as to displace at least one end of the first roller when the loading door enters the closed position; and
  - (e) wherein the housing comprises extension walls located proximate opposite exterior sides of the housing that extend above a top side of the housing, and wherein the method further comprises a preliminary step of mounting the dispenser to the underside of a fixture, including removing a portion of each extension wall along a score line so as to adjust the distance from the underside of the fixture below which the top side of the housing is mounted.
164. The method of claim 160, comprising:
- (a) using a motor assembly configured to cause a leading edge of the toweling to be extended from a housing of the dispenser and to cause the toweling to be subsequently retracted back into the housing, performing said steps of extending the toweling exterior of the housing for grasping by a user and subsequent thereto, retracting the toweling into the housing;

- (b) using a sensor for sensing a leading edge of the toweling, sensing a leading edge of the toweling while retracting the toweling;
  - (c) ceasing retracting of the toweling into the housing using the motor assembly as a function of sensing the leading edge of the toweling by the sensor;
  - (d) wherein the housing comprises,
    - (i) a main body, and
    - (ii) a loading door that is configured to rotate relative to the main body between,
      - (C) a closed position, in which the housing is configured to extend toweling there from, and
      - (B) an open position, in which the housing is configured to receive toweling therein, and
    - (iii) a guide system that is configured to guide the toweling within the housing during extension from and retraction into the housing of the toweling, the guide system comprising a first roller attached to the main body and having a first toothed surface, and a second roller attached to the loading door and having a second toothed surface that is configured to mesh with the first toothed surface, at least one end of the first roller being configured to move such that an axis of rotation of the first roller moves relative to the main body of the housing;
  - (e) wherein the method further comprises the step of moving the loading door into the closed position after loading toweling within the dispenser, with the first roller being urged into engagement with the second roller when the loading door enters the closed position and the second roller acting on the first roller so as to displace at least one end of the first roller when the loading door enters the closed position; and
  - (f) wherein the housing comprises extension walls located proximate opposite exterior sides of the housing that extend above a top side of the housing, and wherein the method further comprises a preliminary step of mounting the dispenser to the underside of a fixture, including removing a portion of each extension wall along a score line so as to adjust the distance from the underside of the fixture below which the top side of the housing is mounted.
165. The method of claim 160, further comprising:
- (a) using a motor assembly configured to cause a leading edge of the toweling to be extended from a housing of the dispenser and to cause the toweling to be subsequently retracted back into the housing, performing said steps of extending the toweling exterior of the housing for grasping by a user and subsequent thereto, retracting the toweling into the housing;

- (b) using a sensor for sensing a leading edge of the toweling, sensing a leading edge of the toweling while retracting the toweling;
- (c) ceasing retracting of the toweling into the housing using the motor assembly as a function of sensing the leading edge of the toweling by the sensor;
- (d) wherein the housing comprises,
  - (i) a main body, and
  - (ii) a loading door that is configured to rotate relative to the main body between,
    - (A) a closed position, in which the housing is configured to extend toweling there from, and
    - (B) an open position, in which the housing is configured to receive toweling therein,
  - (iii) a guide system that is configured to guide the toweling within the housing during extension from and retraction into the housing of the toweling, the guide system comprising a first roller attached to the main body and having a first toothed surface, and a second roller attached to the loading door and having a second toothed surface that is configured to mesh with the first toothed surface, at least one end of the first roller being configured to move such that an axis of rotation of the first roller moves relative to the main body of the housing;
- (e) wherein the loading door comprises a towel carrier having a curved surface defining a cavity within which toweling comprising a roll of paper towels is received and retained in floating engagement therewith, the roll of paper towels rolling and sliding on the curved surface when unwinding during said step of extending the toweling exterior of the housing for grasping by a user, and toweling gathering within the housing during retracting of the toweling into the housing and not being wound back onto the roll of paper towels;
- (f) wherein the method further comprises the step of moving the loading door into the closed position after loading toweling within the dispenser, with the first roller being urged into engagement with the second roller when the loading door enters the closed position and the second roller acting on the first roller so as to displace at least one end of the first roller when the loading door enters the closed position and
- (g) wherein the housing comprises extension walls located proximate opposite exterior sides of the housing that extend above a top side of the housing, and wherein the method further comprises a preliminary step of mounting the dispenser to the underside of a fixture, including removing a portion of each extension wall along a score line so as to adjust the distance from the underside of the fixture below which the top side of the housing is mounted.

166. A towel dispenser, comprising:
- (a) a housing for receiving toweling, comprising
    - (i) a main body,
    - (ii) a loading door that is configured to rotate relative to the main body between,
      - (A) a closed position, in which the housing is configured to dispense towels there from, and
      - (B) an open position, in which the housing is configured to receive toweling therein,
    - (iii) a guide system that is configured to guide the toweling within the housing while towels are dispensed from the housing, and
    - (iv) a motor assembly configured to cause a leading edge of the toweling to be extended from the housing and to cause the toweling to be retracted into the housing after the leading edge has been extended;
  - (b) wherein a back side of the housing includes an opening configured to permit excess toweling to fall there through during retraction of the toweling back into the housing by the motor assembly.
167. The towel dispenser of claim 166, further comprising a sensor for sensing a leading edge of the toweling during retraction of the toweling by the motor assembly, and
- (a) wherein the sensor is configured to cause the motor assembly to cease retracting the toweling into the housing as a function of the sensing of the leading edge of the toweling during retraction of the toweling into the housing;
  - (b) wherein the guide system comprises a first roller attached to the main body and having a first toothed surface, and a second roller attached to the loading door and having a second toothed surface that is configured to mesh with the first toothed surface;
  - (c) wherein the loading door comprises a towel carrier having a curved surface defining a cavity configured to receive the roll of paper towels in floating engagement therewith such that the roll of paper towels rolls and slides on the curved surface during unwinding;
  - (d) wherein at least one end of the first roller moves such that an axis of rotation of the first roller moves relative to the main body of the housing;
  - (e) wherein the first roller is spring biased toward engagement with the second roller when the loading door is in the closed position; and
  - (f) wherein the toothed surfaces of the first roller and the second roller mesh together when the loading door moves into the closed position from the open position and do not preclude the loading door from moving into the closed position from the open position.

168. The towel dispenser of claim 166, further comprising a sensor for sensing a leading edge of the toweling during retraction of the toweling by the motor assembly, and
- (a) wherein the sensor is configured to cause the motor assembly to cease retracting the toweling into the housing as a function of the sensing of the leading edge of the toweling during retraction of the toweling into the housing;
  - (b) wherein the loading door comprises a towel carrier having a curved surface defining a cavity configured to receive the roll of paper towels in floating engagement therewith such that the roll of paper towels rolls and slides on the curved surface during unwinding; and
  - (c) wherein the housing further comprises extension walls located proximate opposite exterior sides of the housing that extends above a top side of the housing, each extension wall comprising a weakened line extending parallel to a weakened line of the other extension walls, whereby the extent above the top side at which each extension walls extends may be changed, the extent representing a distance from the underside of a fixture below which the top side of the housing is mounted when the towel dispenser is installed under the fixture.
169. The towel dispenser of claim 166,
- (a) wherein the guide system comprises a first roller attached to the main body and having a first toothed surface, and a second roller attached to the loading door and having a second toothed surface that is configured to mesh with the first toothed surface;
  - (b) wherein the loading door comprises a towel carrier having a curved surface defining a cavity configured to receive the roll of paper towels in floating engagement therewith such that the roll of paper towels rolls and slides on the curved surface during unwinding;
  - (c) wherein at least one end of the first roller moves such that an axis of rotation of the first roller moves relative to the main body of the housing;
  - (d) wherein the first roller is spring biased toward engagement with the second roller when the loading door is in the closed position;
  - (e) wherein the toothed surfaces of the first roller and the second roller mesh together when the loading door moves into the closed position from the open position and do not preclude the loading door from moving into the closed position from the open position; and
  - (f) wherein the housing further comprises extension walls located proximate opposite exterior sides of the housing that extends above a top side of the housing, each extension wall comprising a weakened line extending parallel to a weakened line of the other extension walls, whereby the extent above the top side at which each

extension walls extends may be changed, the extent representing a distance from the underside of a fixture below which the top side of the housing is mounted when the towel dispenser is installed under the fixture.

170. The towel dispenser of claim 166, further comprising a sensor for sensing a leading edge of the toweling during retraction of the toweling by the motor assembly, and
- (a) wherein the sensor is configured to cause the motor assembly to cease retracting the toweling into the housing as a function of the sensing of the leading edge of the toweling during retraction of the toweling into the housing;
  - (a) wherein the guide system comprises a first roller attached to the main body and having a first toothed surface, and a second roller attached to the loading door and having a second toothed surface that is configured to mesh with the first toothed surface;
  - (b) wherein at least one end of the first roller moves such that an axis of rotation of the first roller moves relative to the main body of the housing;
  - (c) wherein the first roller is spring biased toward engagement with the second roller when the loading door is in the closed position;
  - (d) wherein the toothed surfaces of the first roller and the second roller mesh together when the loading door moves into the closed position from the open position and do not preclude the loading door from moving into the closed position from the open position; and
  - (e) wherein the housing further comprises extension walls located proximate opposite exterior sides of the housing that extends above a top side of the housing, each extension wall comprising a weakened line extending parallel to a weakened line of the other extension walls, whereby the extent above the top side at which each extension walls extends may be changed, the extent representing a distance from the underside of a fixture below which the top side of the housing is mounted when the towel dispenser is installed under the fixture.
171. The towel dispenser of claim 166, further comprising a sensor for sensing a leading edge of the toweling during retraction of the toweling by the motor assembly, and
- (a) wherein the sensor is configured to cause the motor assembly to cease retracting the toweling into the housing as a function of the sensing of the leading edge of the toweling during retraction of the toweling into the housing;
  - (b) wherein the guide system comprises a first roller attached to the main body and having a first toothed surface, and a second roller attached to the loading door and having a second toothed surface that is configured to mesh with the first toothed surface;

- (c) wherein the loading door comprises a towel carrier having a curved surface defining a cavity configured to receive the roll of paper towels in floating engagement therewith such that the roll of paper towels rolls and slides on the curved surface during unwinding;
  - (d) wherein at least one end of the first roller moves such that an axis of rotation of the first roller moves relative to the main body of the housing,
  - (e) wherein the first roller is spring biased toward engagement with the second roller when the loading door is in the closed position;
  - (f) wherein the toothed surfaces of the first roller and the second roller mesh together when the loading door moves into the closed position from the open position and do not preclude the loading door from moving into the closed position from the open position; and
  - (g) wherein the housing further comprises extension walls located proximate opposite exterior sides of the housing that extends above a top side of the housing, each extension wall comprising a weakened line extending parallel to a weakened line of the other extension walls, whereby the extent above the top side at which each extension walls extends may be changed, the extent representing a distance from the underside of a fixture below which the top side of the housing is mounted when the towel dispenser is installed under the fixture.
172. A towel dispenser, comprising:
- (a) a housing for receiving toweling, wherein the toweling includes towels that are connected together and separable at perforation formed between the towels;
  - (b) a motor configured to selectively cause a leading edge of the toweling to be extended from the housing and to cause the toweling to be retracted into the housing; and
  - (c) a sensor for sensing a leading edge of the toweling;
  - (d) wherein the sensor is configured to cause the motor to cease retracting toweling into the housing in response to the sensing of the leading edge of the toweling.
173. A towel dispenser as disclosed herein.
174. A method of dispensing towels from a dispenser, comprising the steps of:
- (a) providing a towel dispenser including a housing for containing toweling, wherein the toweling includes towels connected together and separable at perforations formed there between; a motor configured to selectively cause a leading edge of the toweling to be extended from the housing and to cause the toweling to be retracted into the housing; and a sensor for sensing a leading edge of the toweling;
  - (b) using the motor, extending the toweling exterior of the housing for grasping by a user;
  - (c) using the motor, retracting the toweling into the housing;

- (d) while retracting the toweling, sensing a leading edge of the toweling using the sensor; and
  - (e) ceasing to retract the toweling into the housing using the motor upon sensing the leading edge of the toweling by the sensor.
175. A method for dispensing a towel as disclosed herein.
176. A method, comprising:
- (a) advancing toweling using a motor of a paper towel dispenser apparatus;
  - (b) determining, via a sensor, when a certain extent of toweling has been advanced;
  - (c) based on said determining when a certain extent of toweling has been advanced, ceasing the advance of the advancing toweling, wherein, upon ceasing the advance of the advancing toweling, a first length of toweling is extended outside of a housing of the paper towel dispenser apparatus;
  - (d) determining, via the sensor, that the length of toweling extended outside of the housing has increased, wherein a second length of toweling is extended outside of the housing of the paper towel dispenser apparatus, the second length being greater than the first length; and
  - (e) in response to said determining that the length of toweling extended outside of the housing has increased, applying force to the toweling, via the motor, in a manner adapted to retract the toweling such that the length of toweling extended outside of the housing decreases.
177. The method of claim 176, wherein said step of applying force to the toweling, via the motor, in a manner adapted to retract the toweling such that the length of toweling extended outside of the housing decreases comprises applying force to the toweling, via the motor, in a manner adapted to retract the toweling such that the length of toweling extended outside of the housing is once again the first length.
178. The method of claim 176, wherein
- (a) said step of advancing toweling comprises providing current of a first polarity to the motor;
  - (b) said step of ceasing the advance of the advancing toweling comprises drawing current out of the motor; and
  - (c) said step of applying force to the toweling, via the motor, comprises providing current of a second polarity to the motor, the second polarity being reverse of the first polarity.
179. The method of claim 176, wherein the sensor comprises a slot sensor.
180. A method, comprising, when a length of toweling is extended outside of a housing of a paper towel dispenser:

- (a) determining, via a sensor, that the length of toweling extended outside of the housing of the paper towel dispenser has increased; and
  - (b) in response to said determining that the length of toweling extended outside of the housing has increased, applying force to the toweling, via the motor, in a manner adapted to retract the toweling such that the length of toweling extended outside of the housing decreases.
181. The method of claim 180, wherein said step of applying force to the toweling, via the motor, in a manner adapted to retract the toweling such that the length of toweling extended outside of the housing decreases comprises applying force to the toweling, via the motor, in a manner adapted to retract the toweling such that the length of toweling extended outside of the housing is once again the first length.
182. The method of claim 180, wherein the sensor comprises a slot sensor.
183. A method, comprising:
- (a) advancing toweling using a motor of a paper towel dispenser apparatus;
  - (b) monitoring, via a sensor, rotation that occurs as toweling is advanced or retracted;
  - (c) determining, via the sensor, that a certain amount of rotation has occurred;
  - (d) based on said determining that a certain amount of rotation has occurred, ceasing the advance of the advancing toweling;
  - (e) after said ceasing of the advance of the advancing toweling, determining, via the sensor, that additional rotation has occurred; and
  - (f) in response to said determining that a certain amount of rotation has occurred, applying force, via the motor, in a manner adapted to counteract the additional rotation.
184. The method of claim 183, wherein said step of applying force, via the motor, in a manner adapted to counteract the additional rotation comprises effecting rotation in a direction opposite the direction of the additional rotation.
185. The method of claim 183, wherein
- (a) said step of advancing toweling comprises providing current of a first polarity to the motor;
  - (b) said step of ceasing the advance of the advancing toweling comprises drawing current out of the motor; and
  - (c) said step of applying force to the toweling, via the motor, comprises providing current of a second polarity to the motor, the second polarity being reverse of the first polarity.
186. The method of claim 183, wherein the sensor comprises a slot sensor.

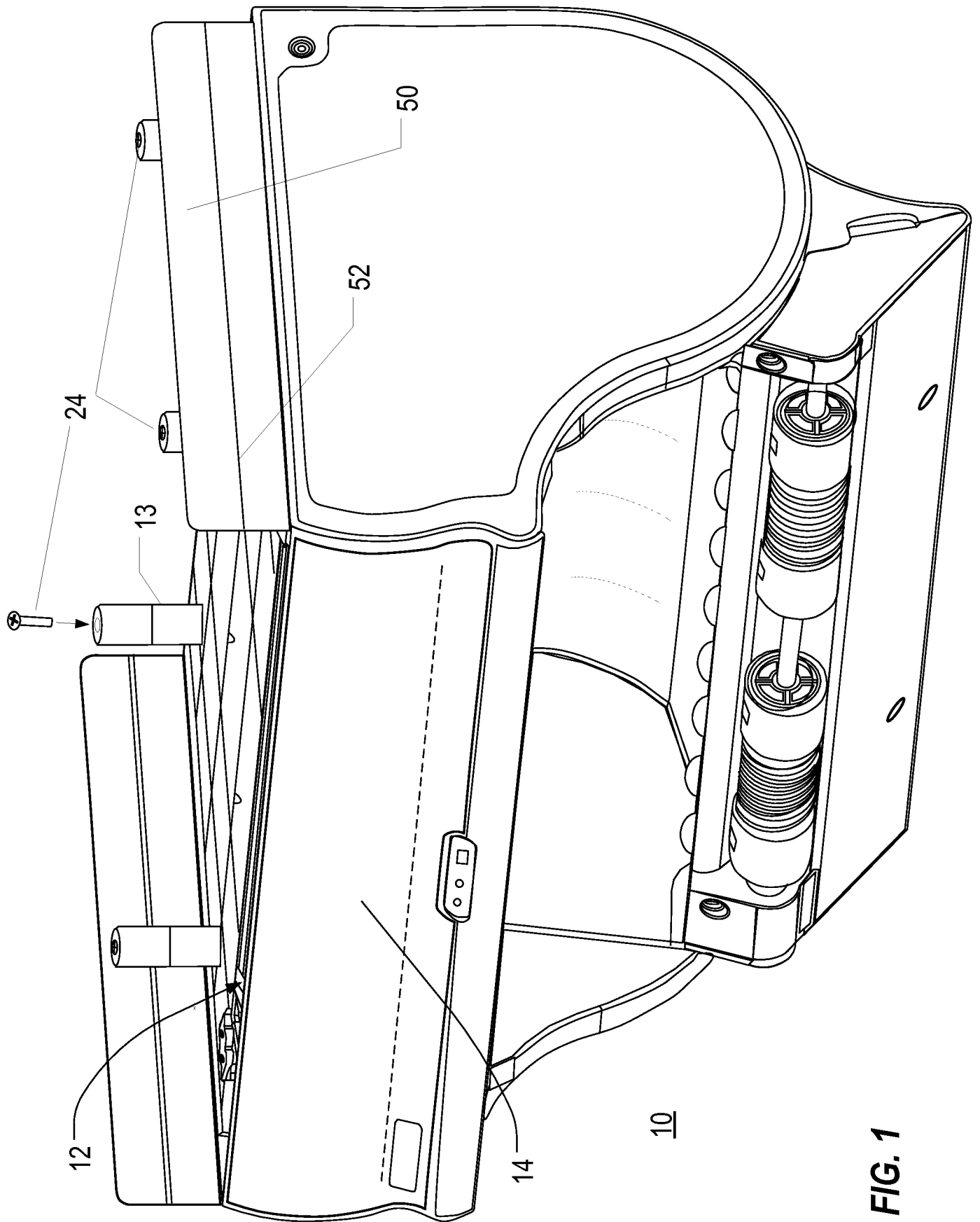

FIG. 1

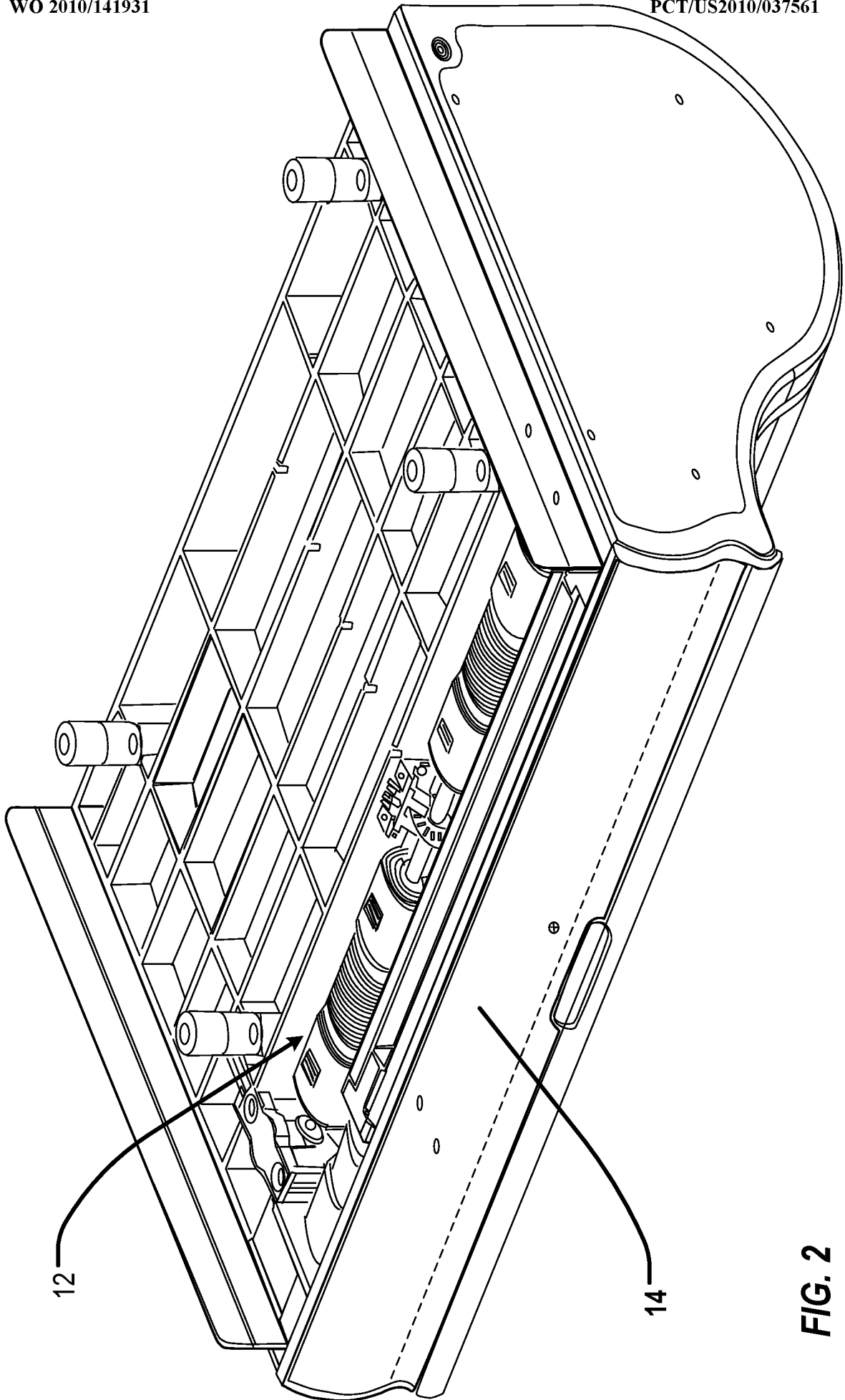

FIG. 2

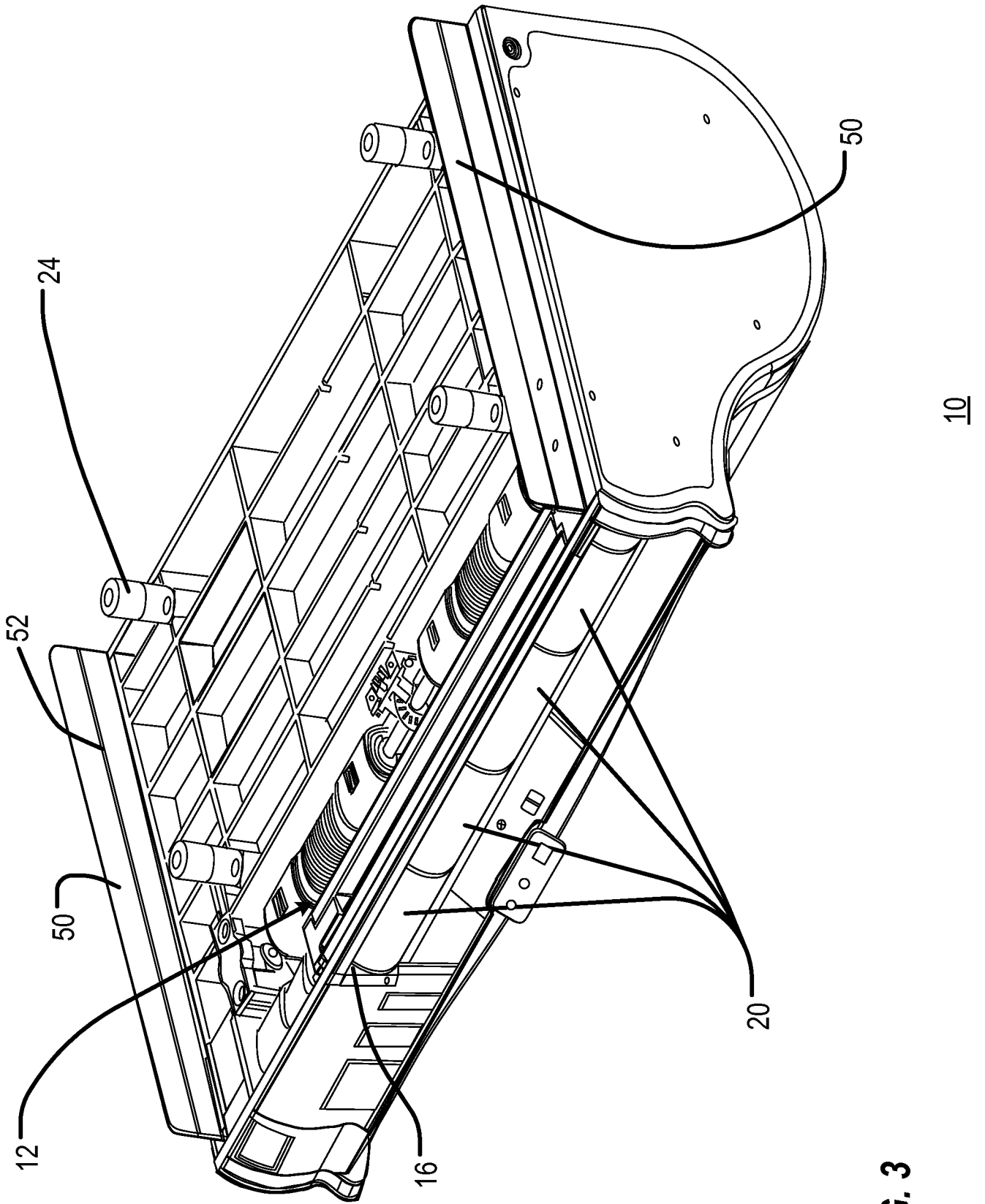
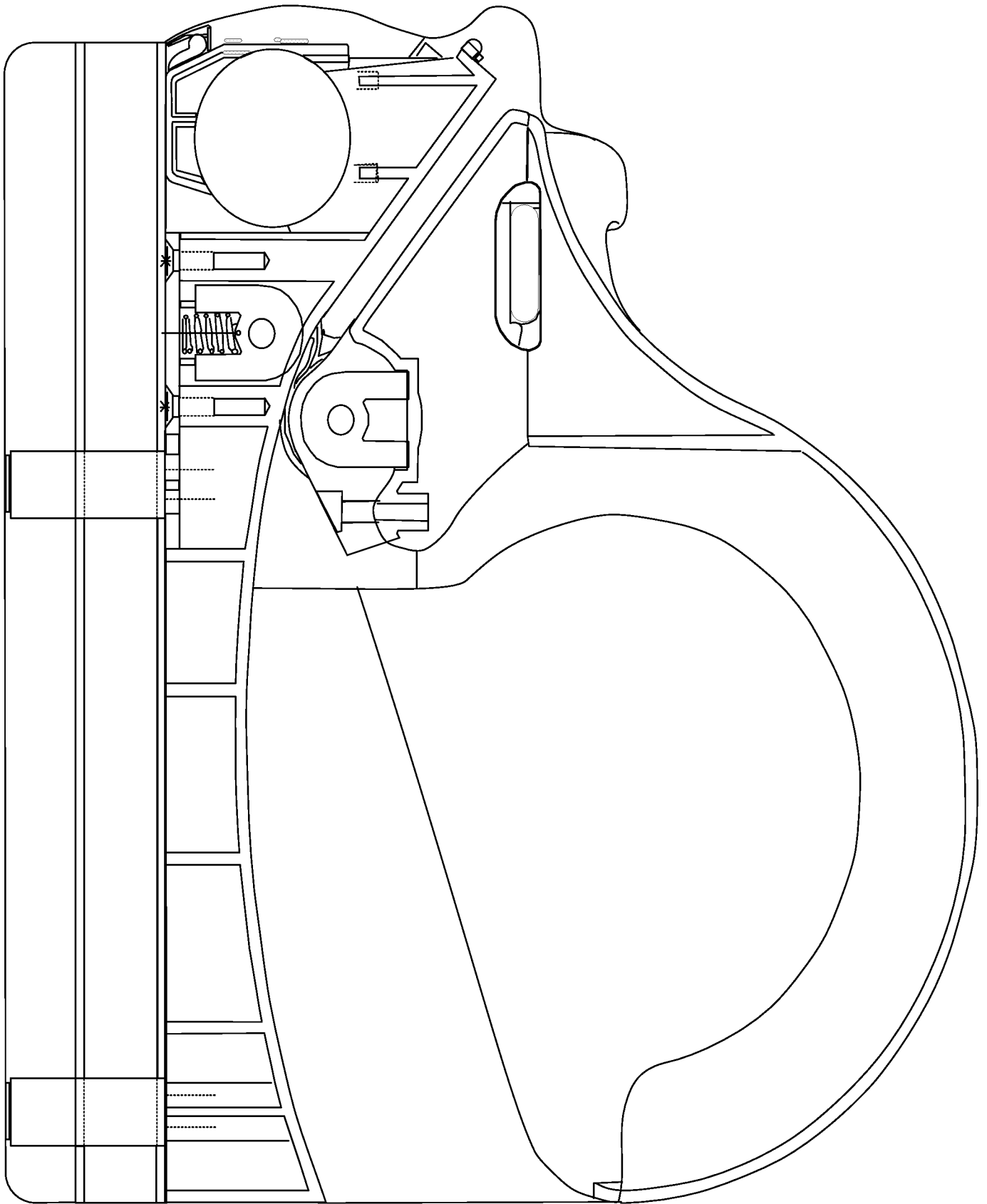
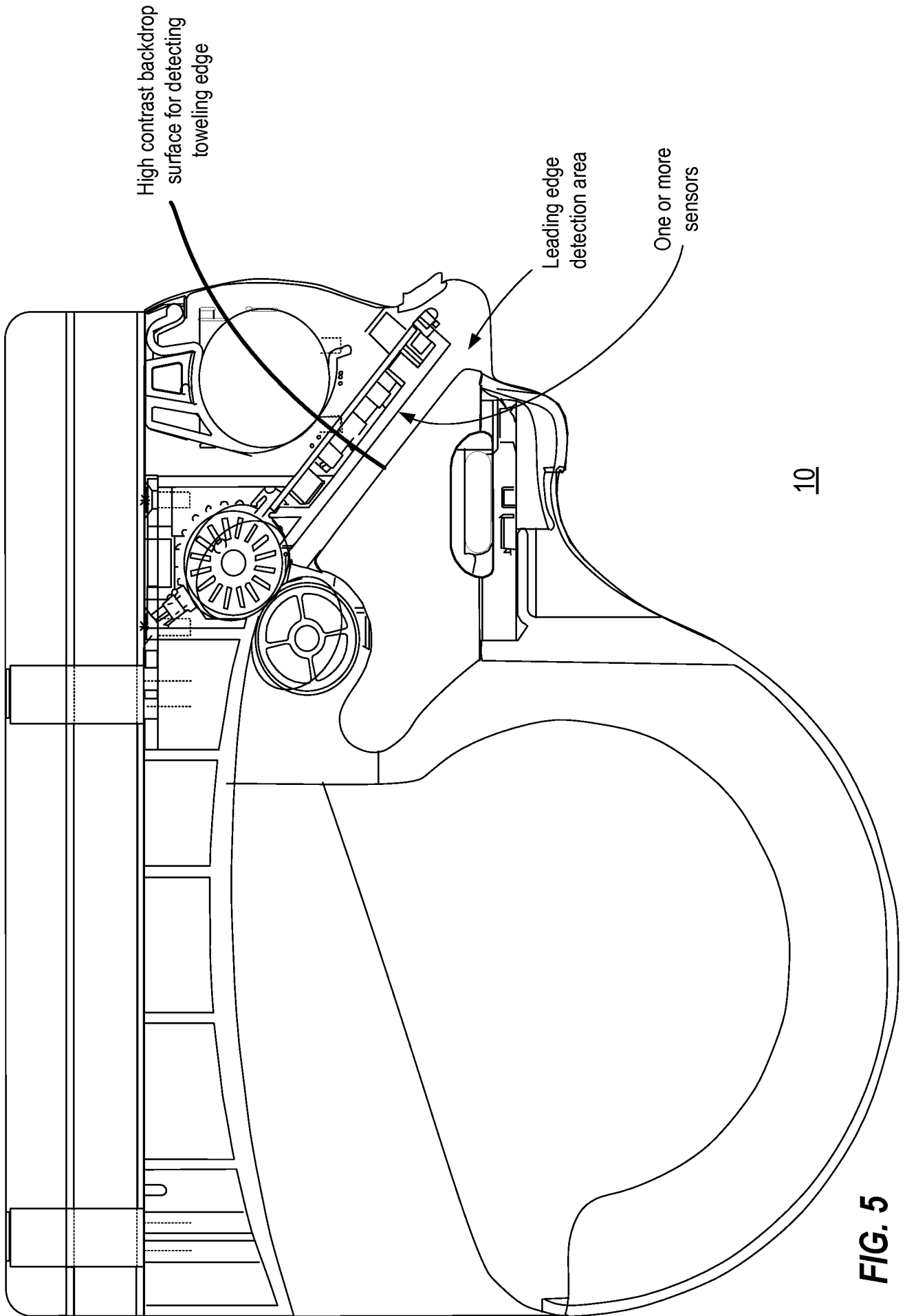

FIG. 3





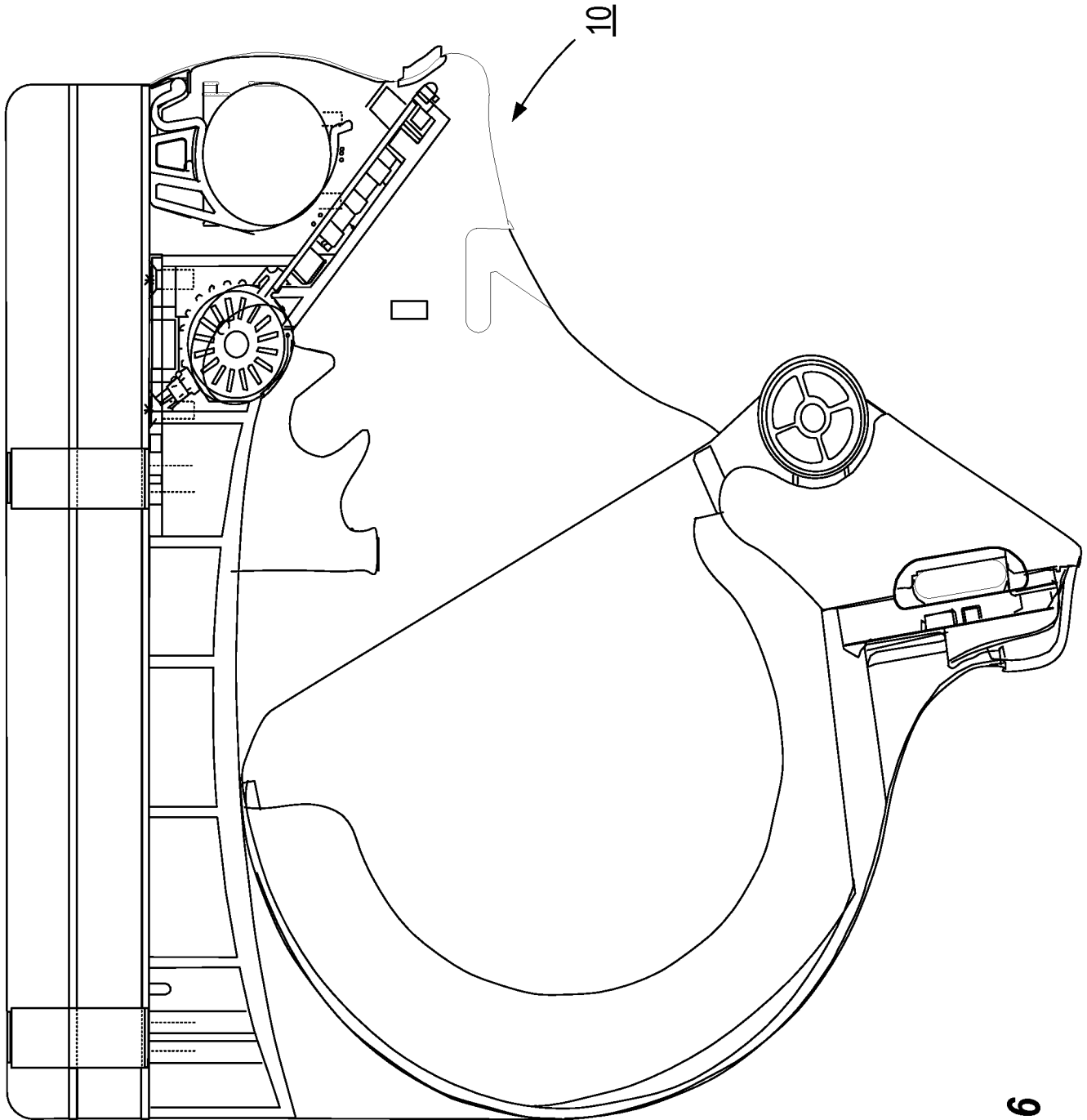
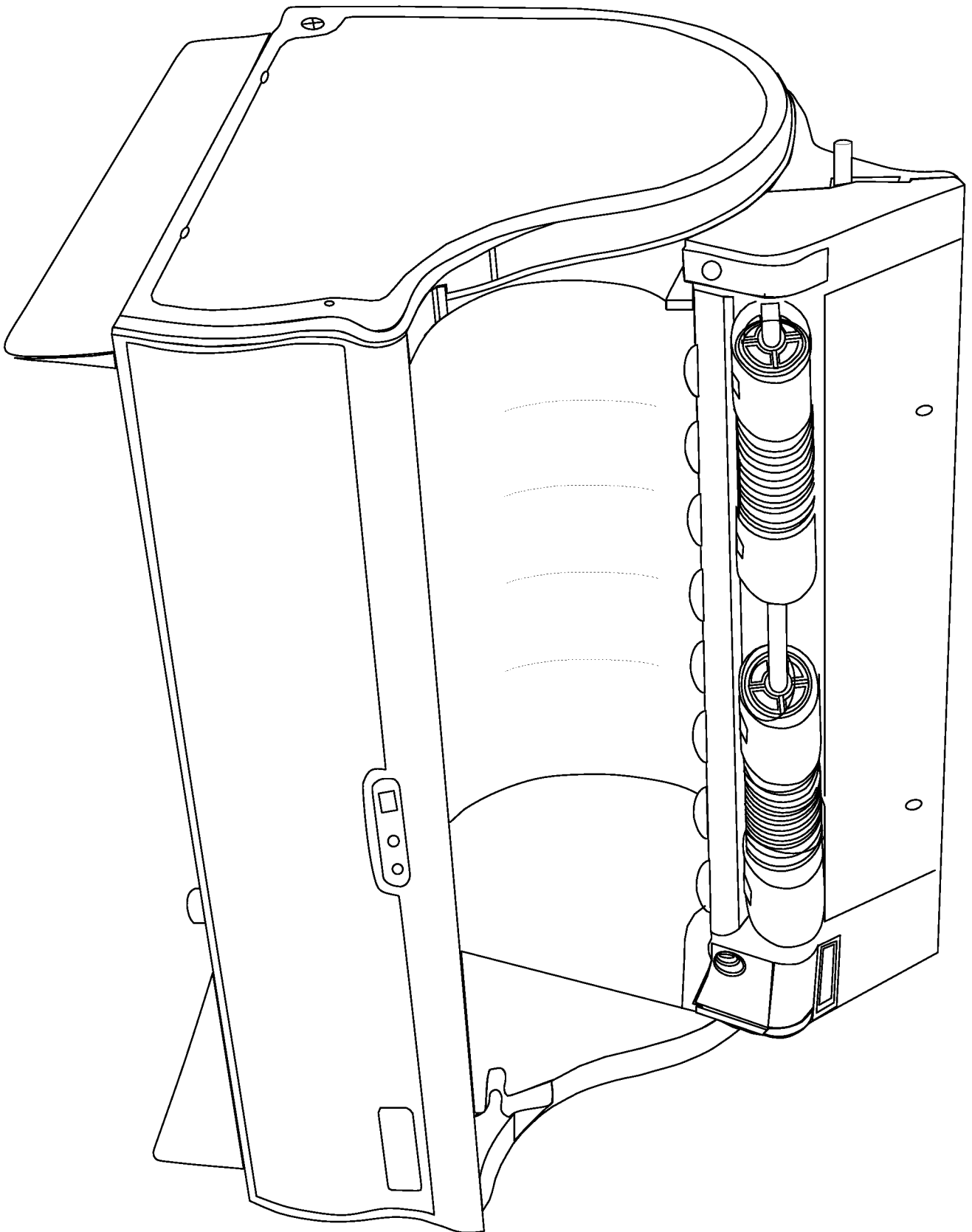
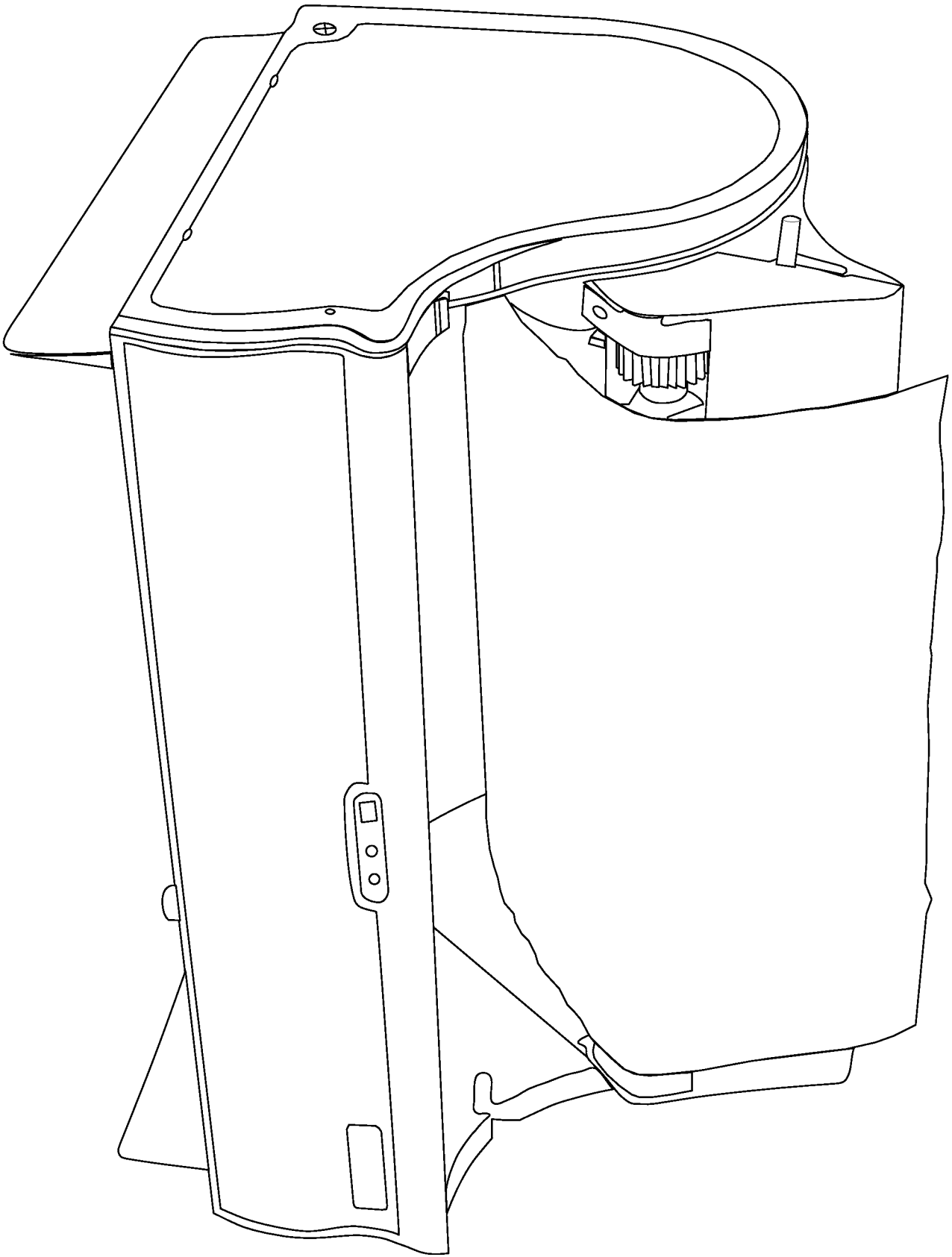

FIG. 6



100

**FIG. 7**



100

**FIG. 8**

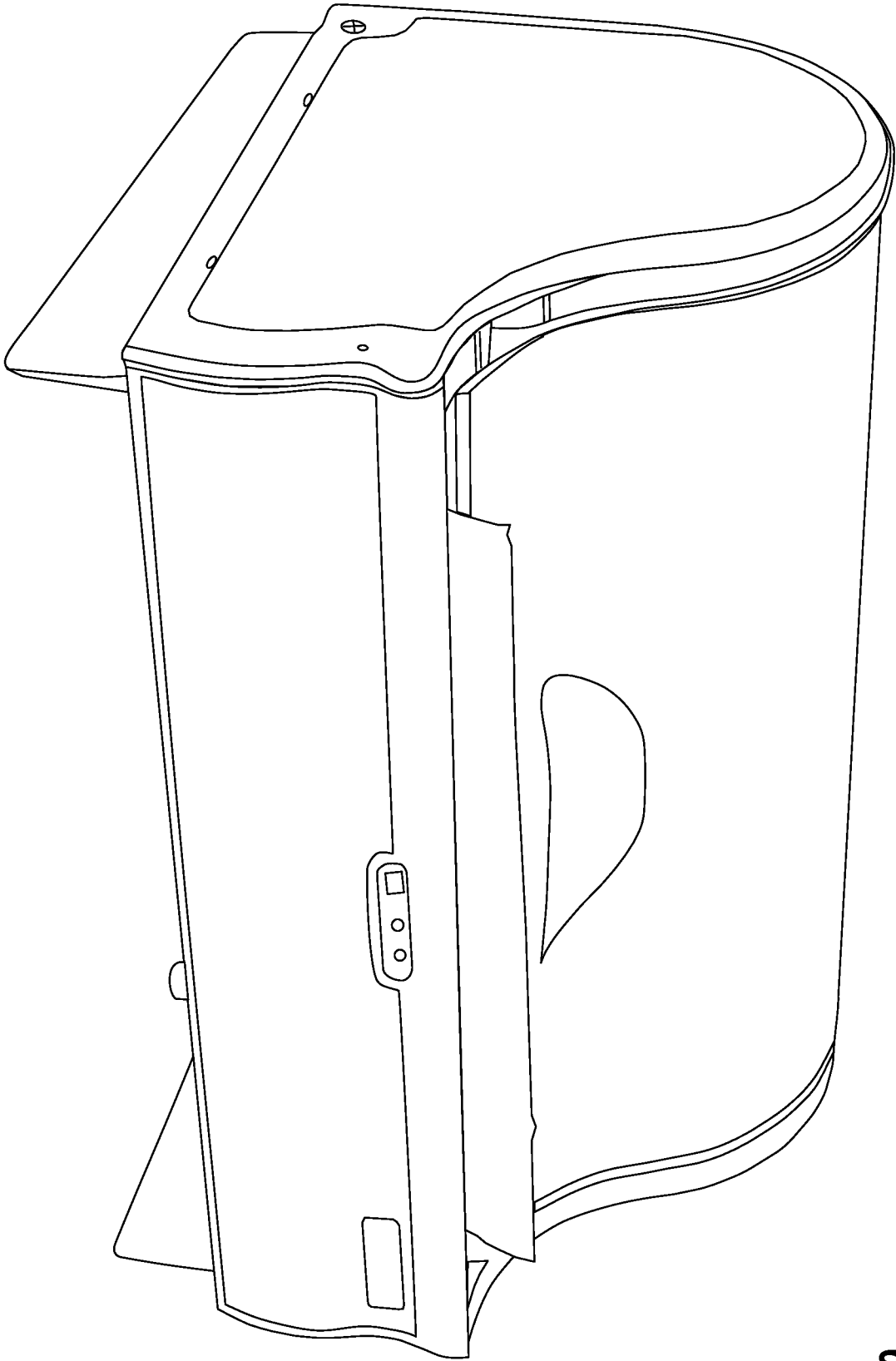

100

**FIG. 9**

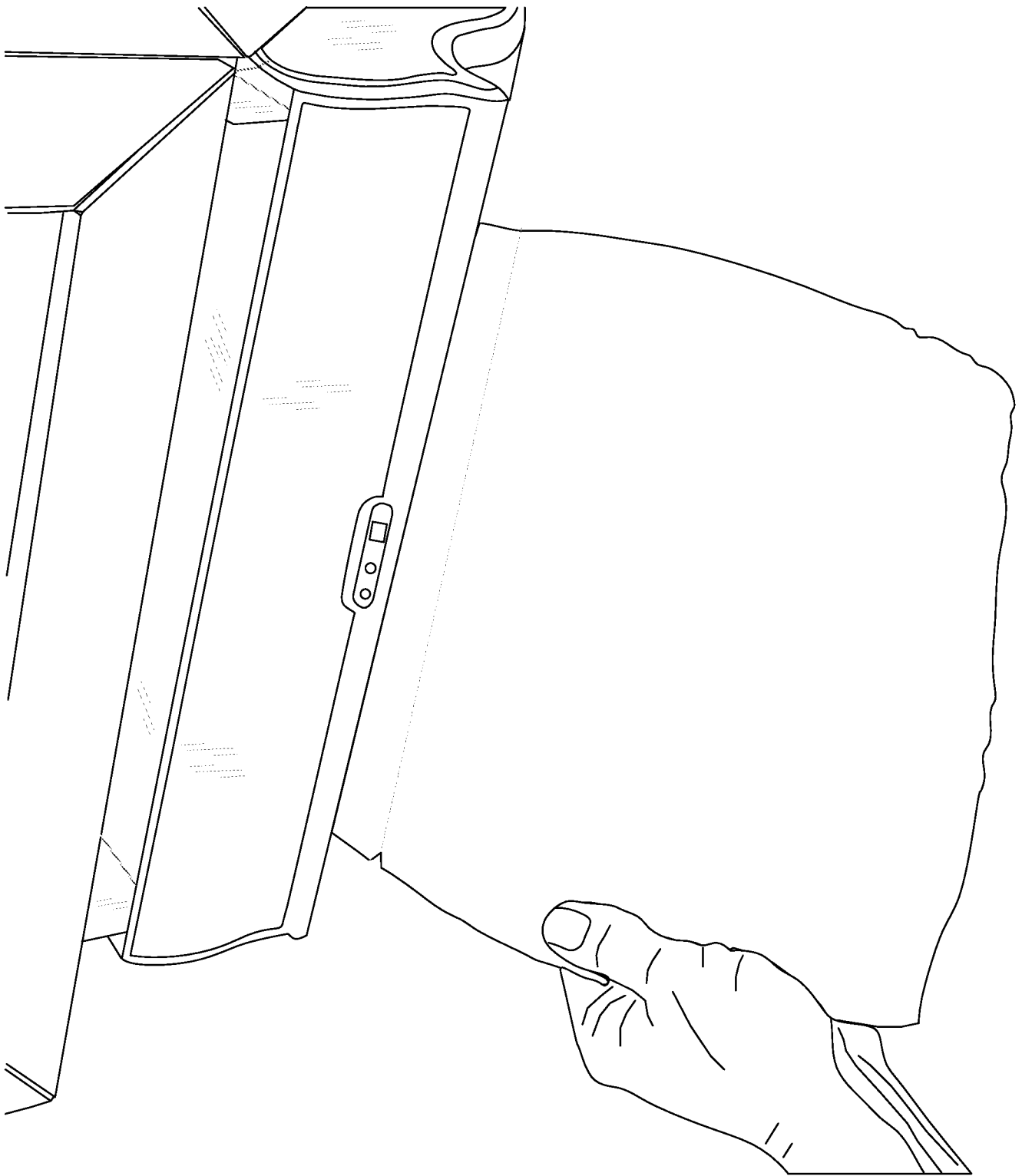

100

FIG. 10

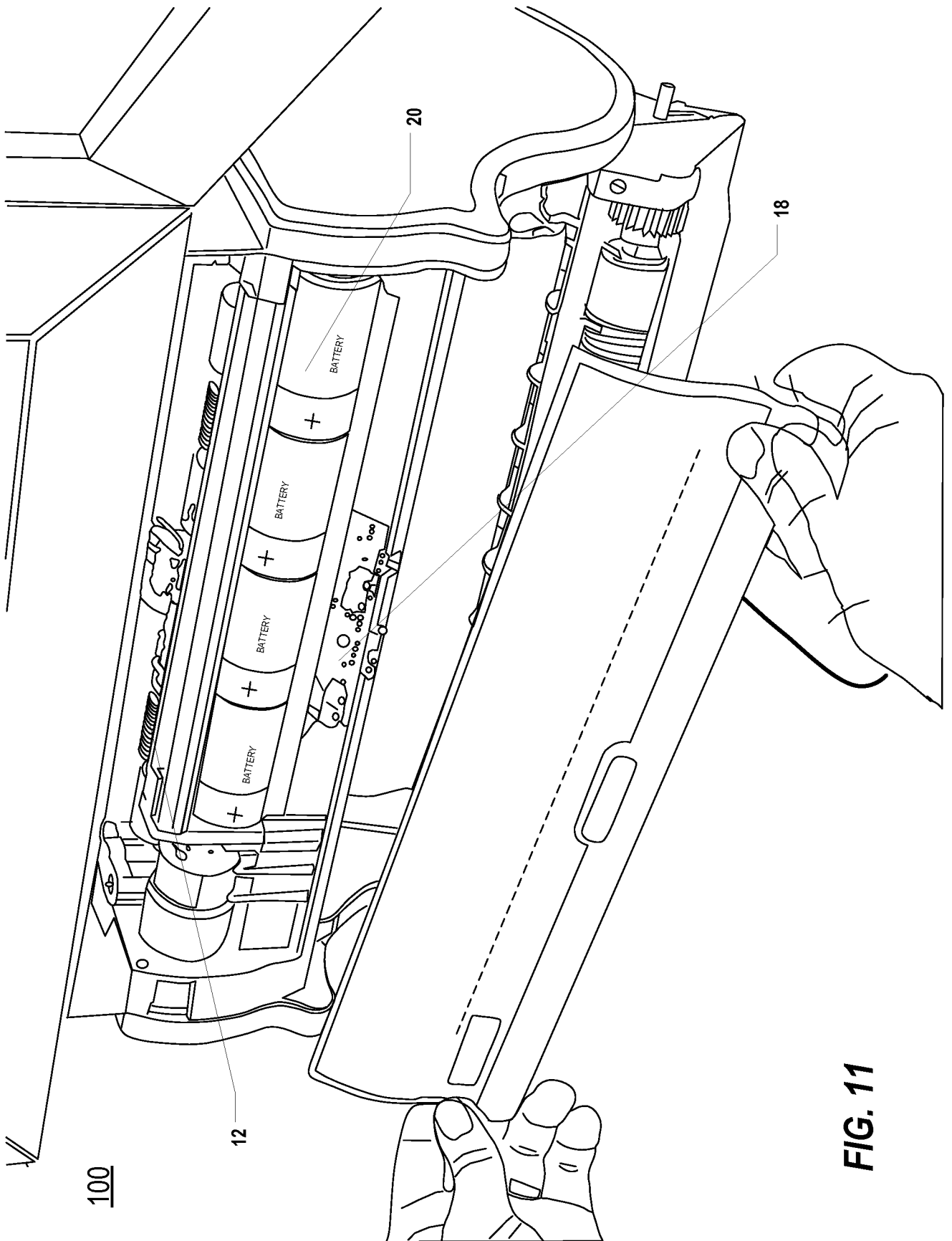
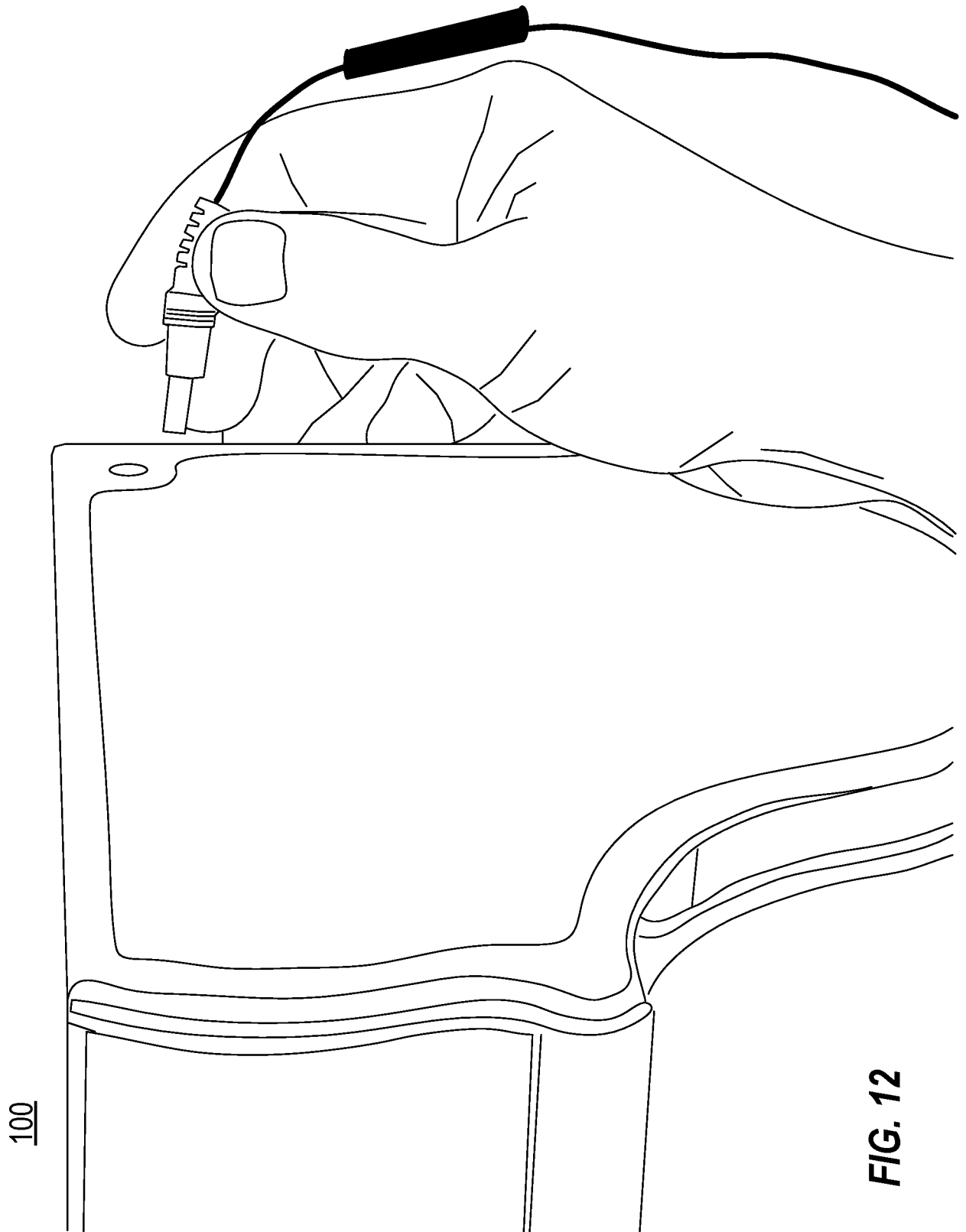
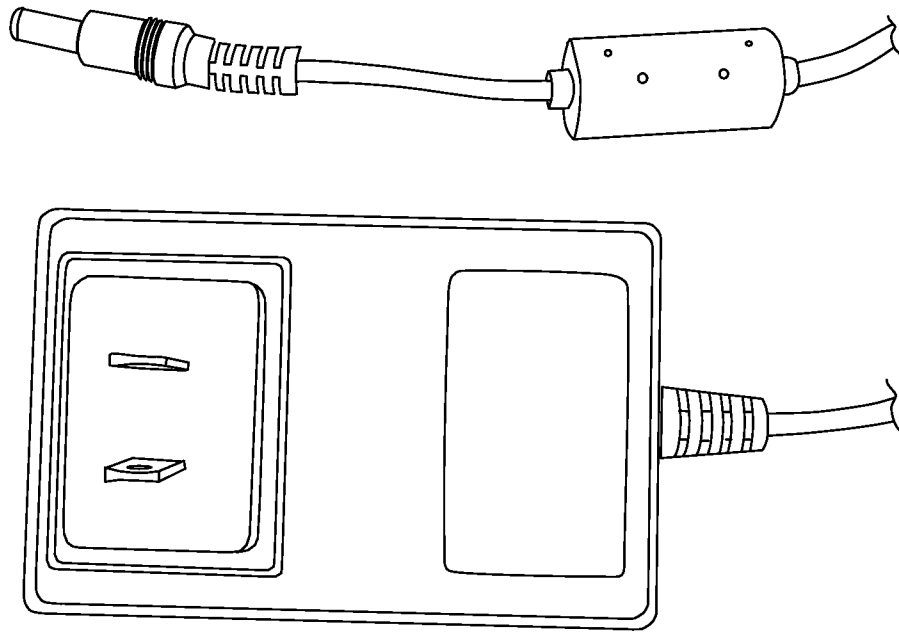

FIG. 11



100

FIG. 12



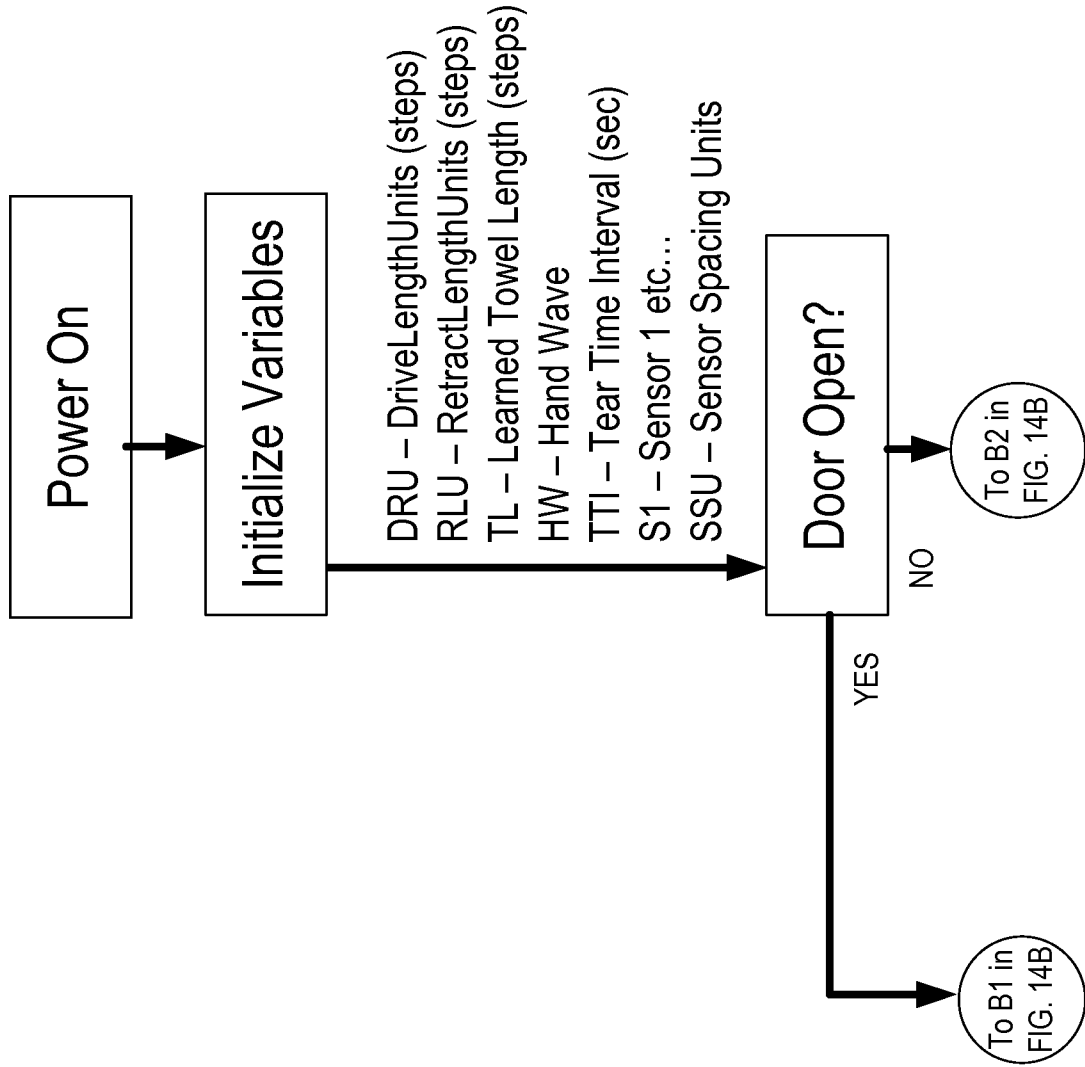
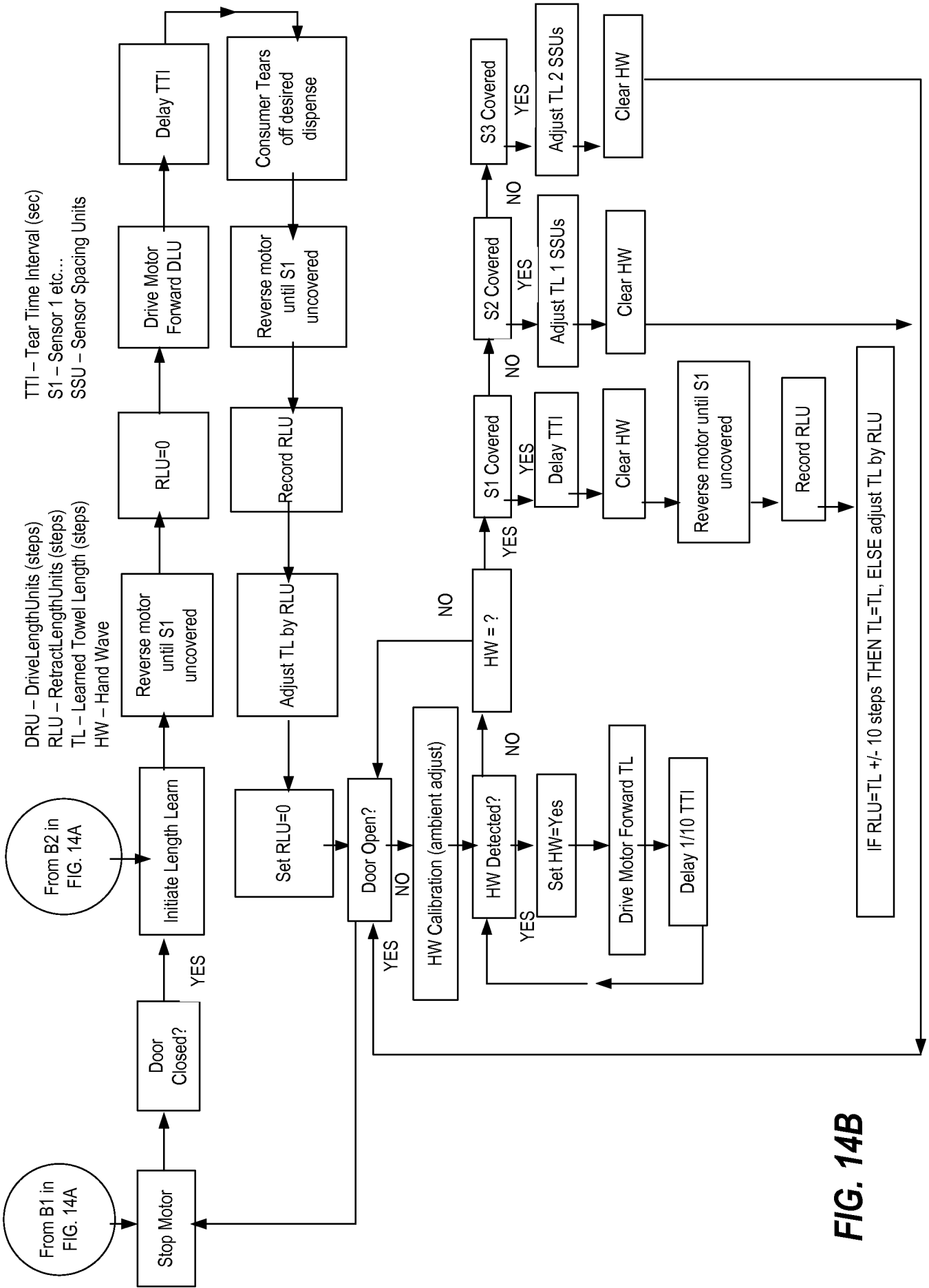

FIG. 14A



**FIG. 14B**





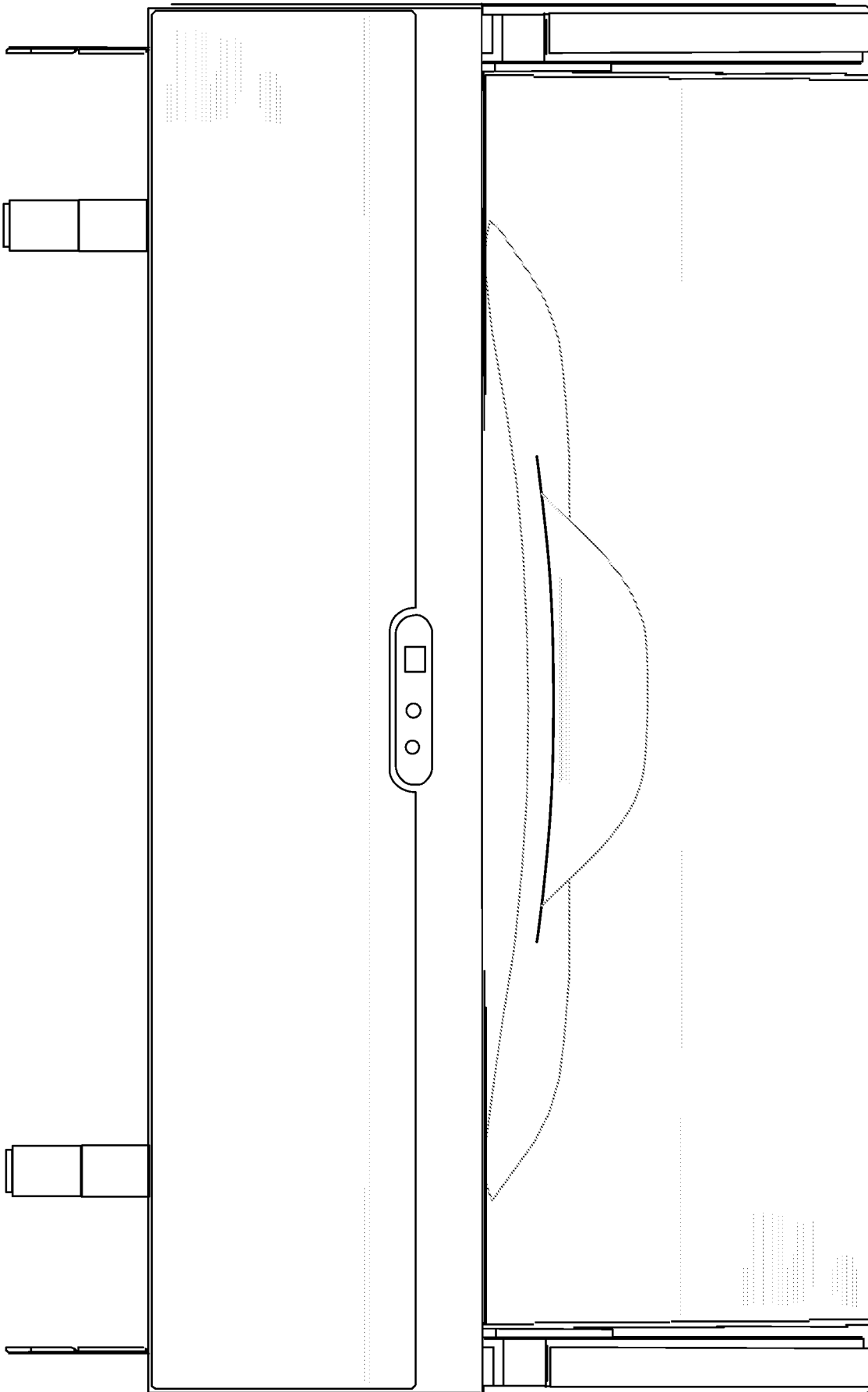

Front Elevational View

FIG. 16

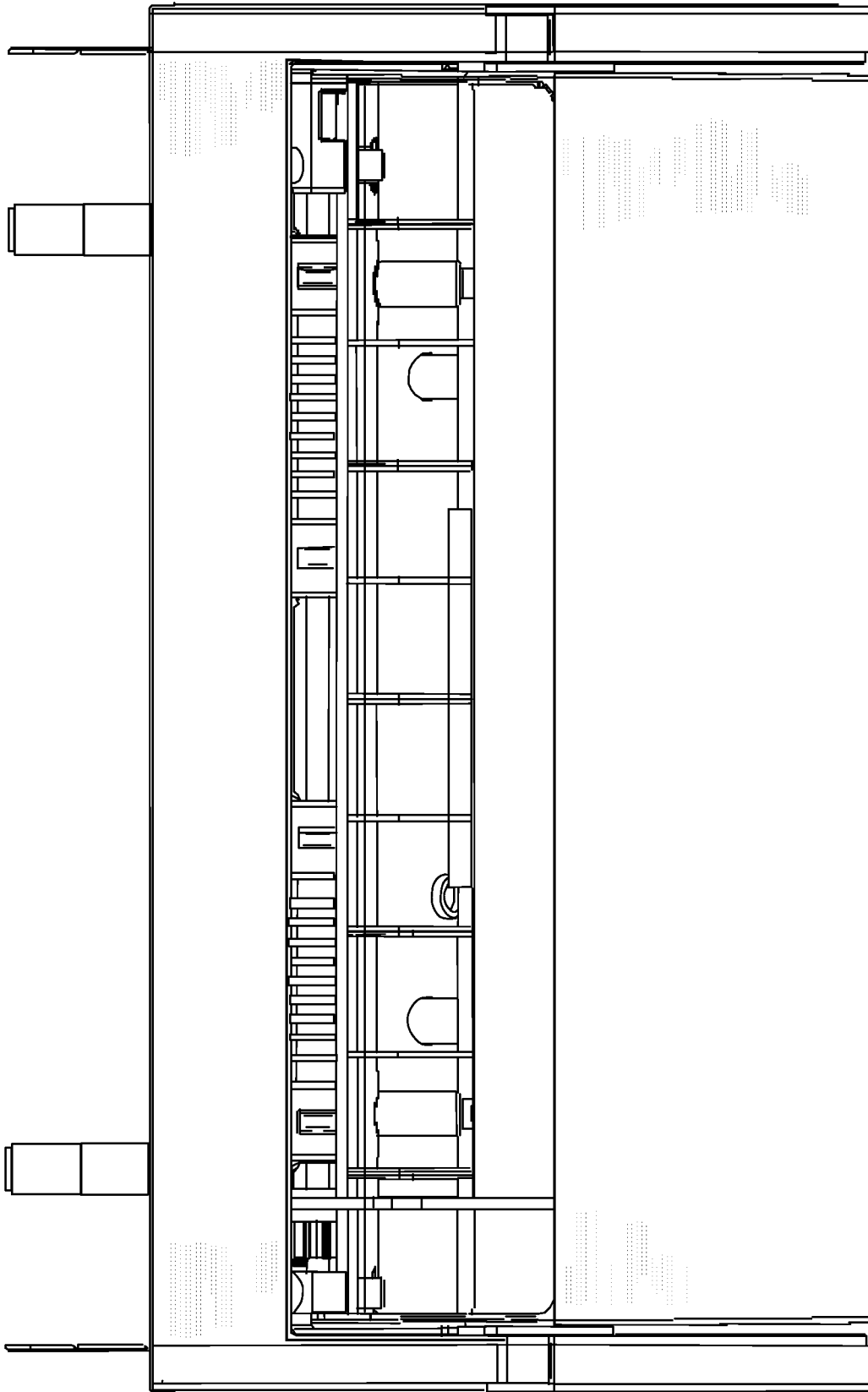

*Back Elevational View*

**FIG. 17**

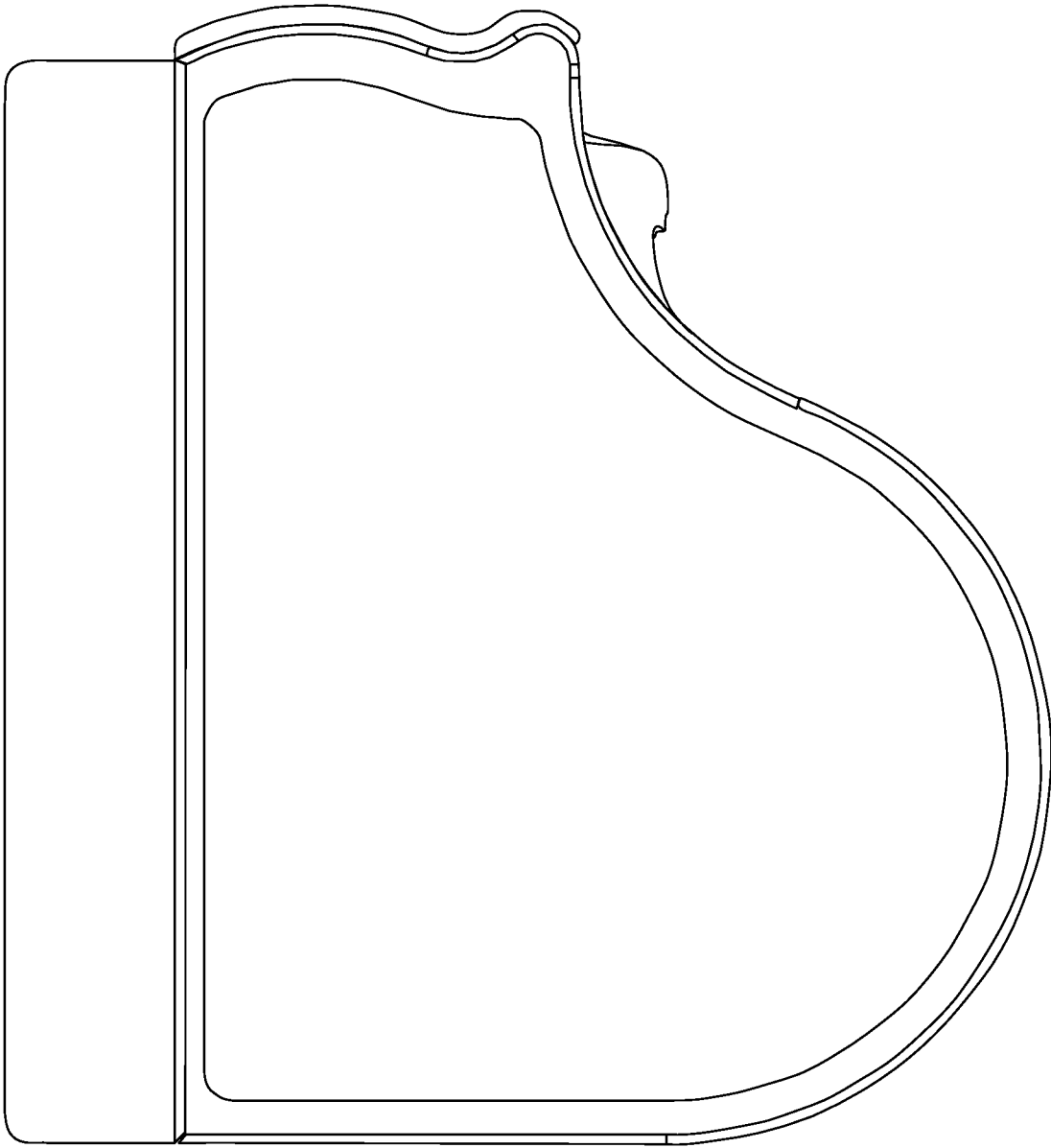

*Left Side Elevational View*

**FIG. 18**

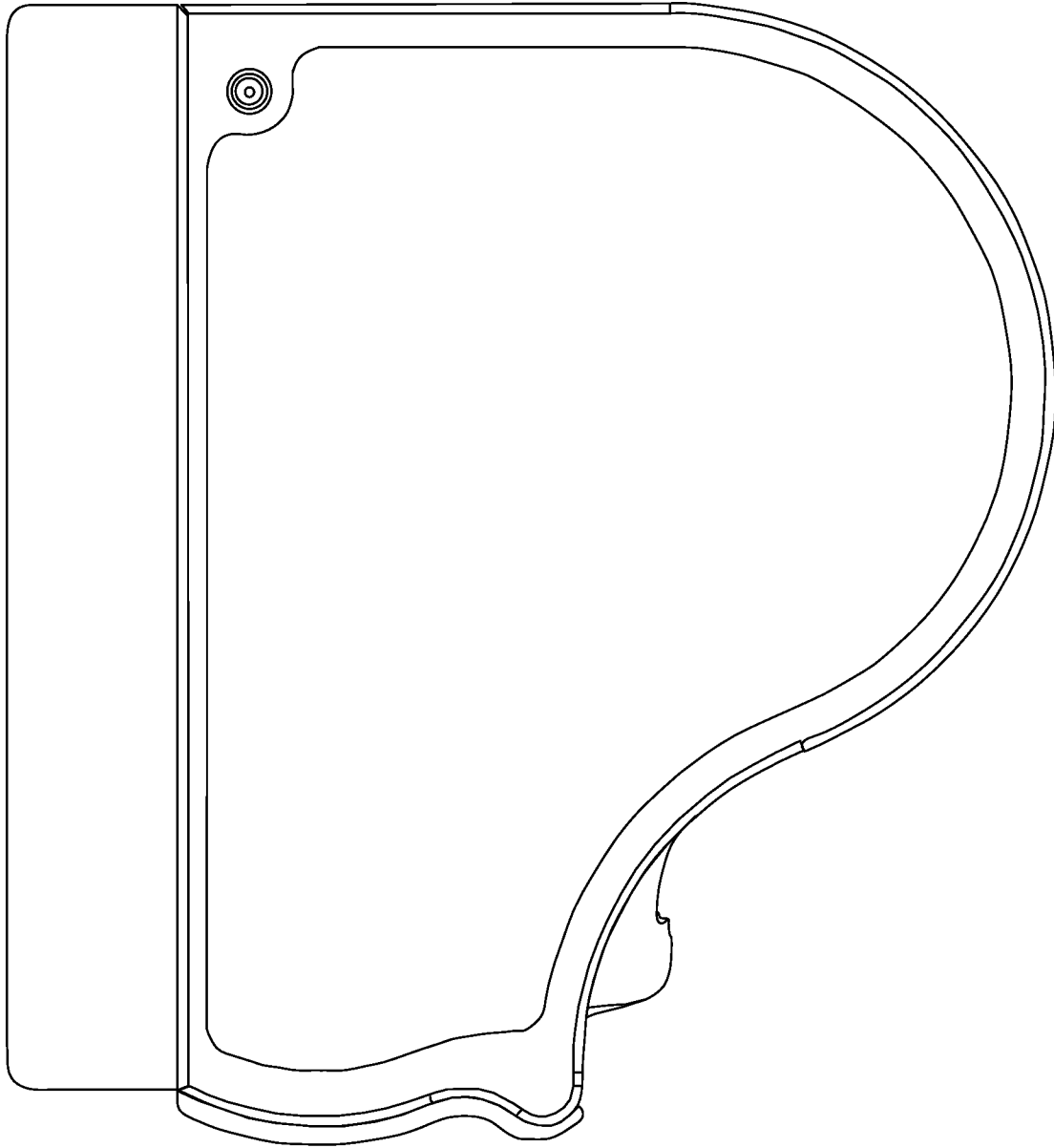

*Right Side Elevational View*

**FIG. 19**

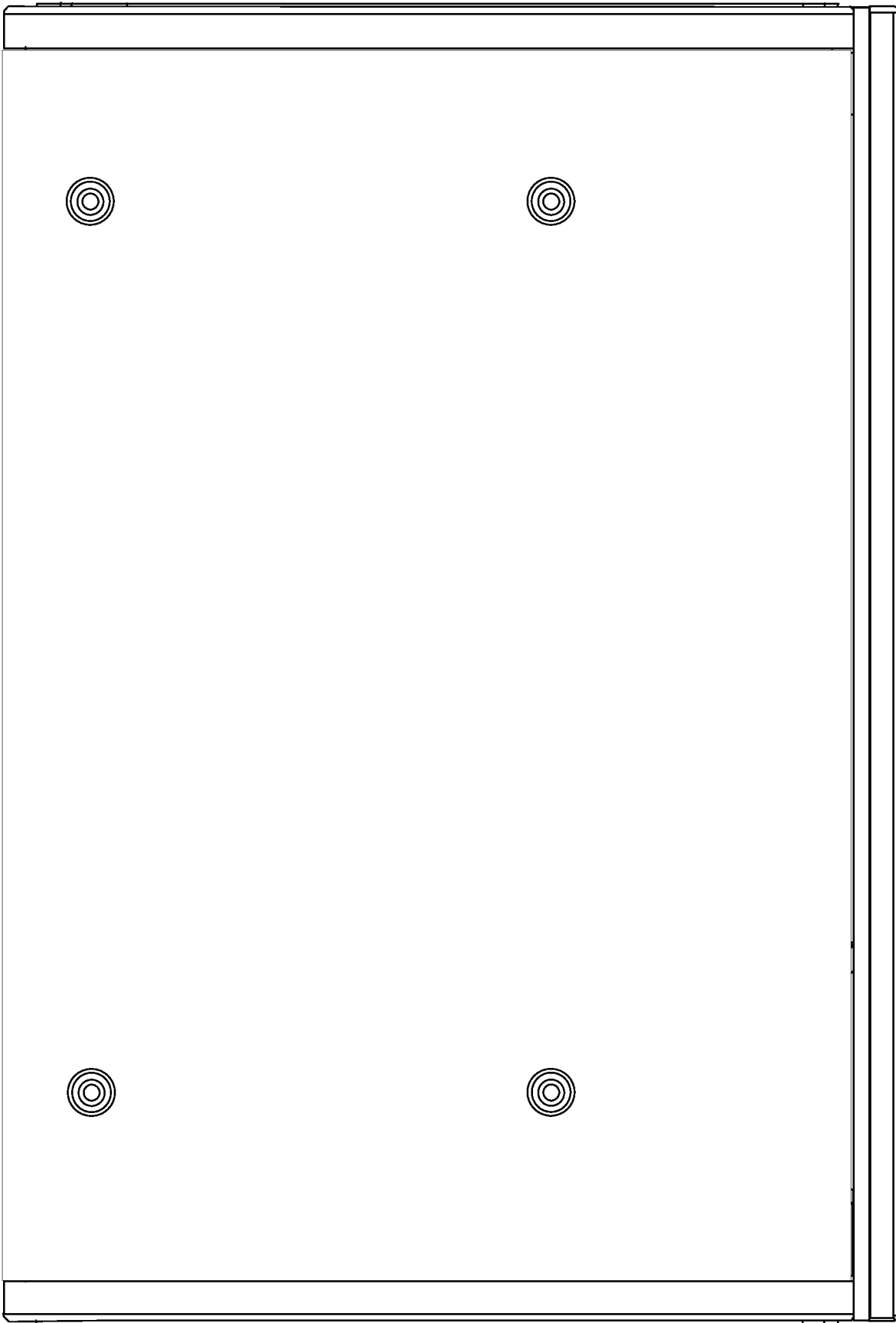

*Top Plan View*

**FIG. 20A**

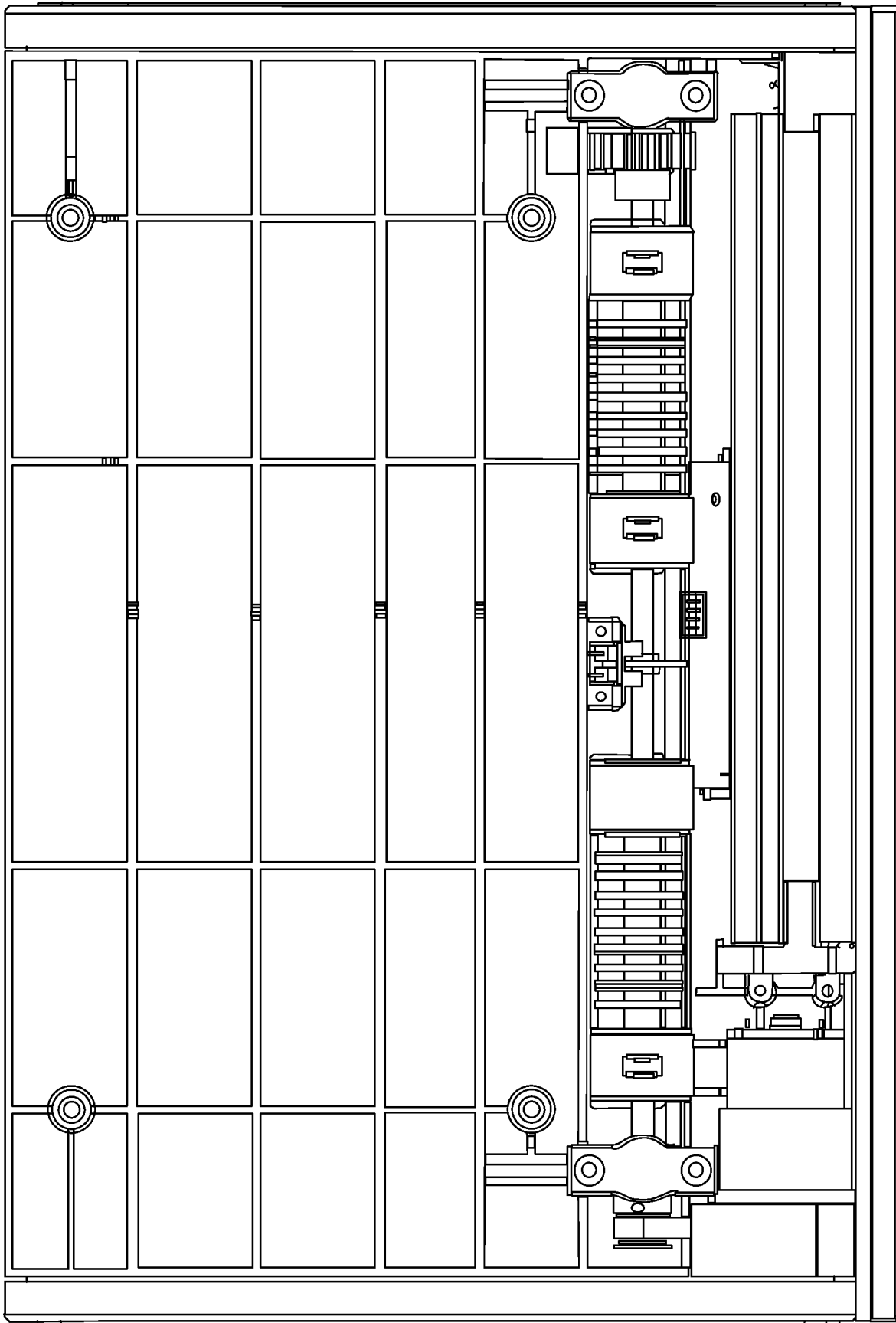

Top Plan View

FIG. 20B

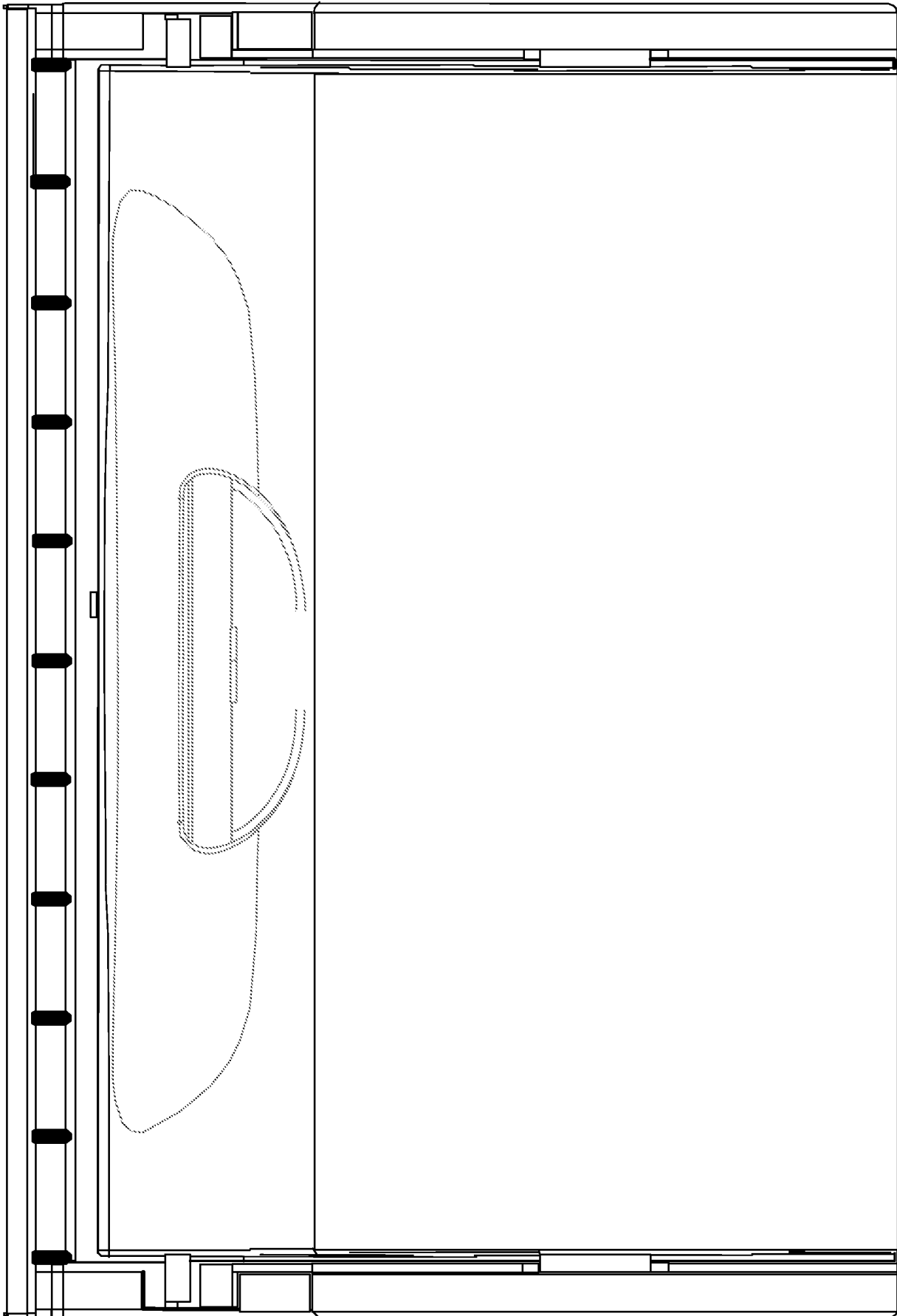

*Bottom Plan View*

**FIG. 21**

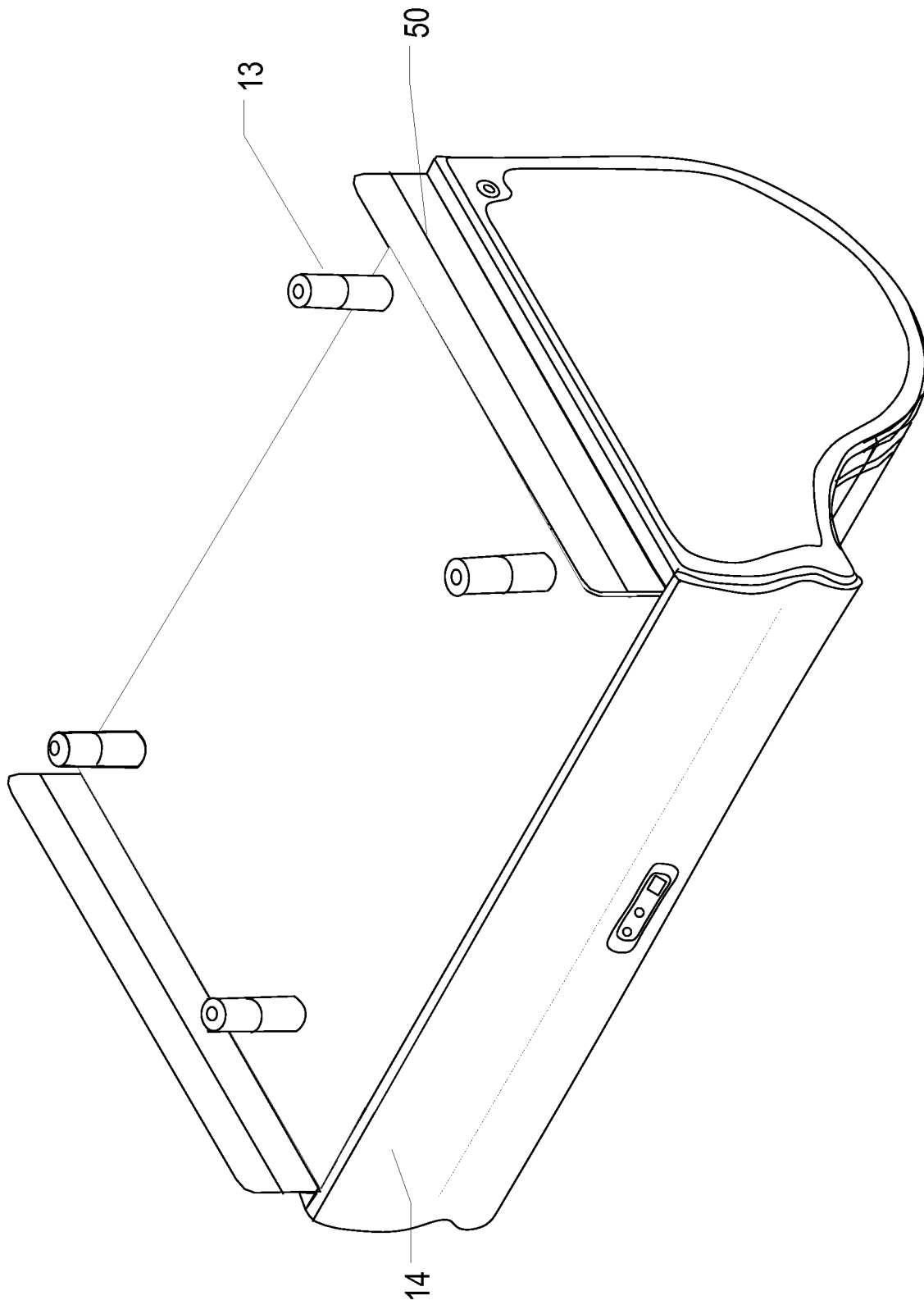

Isometric View

FIG. 22A

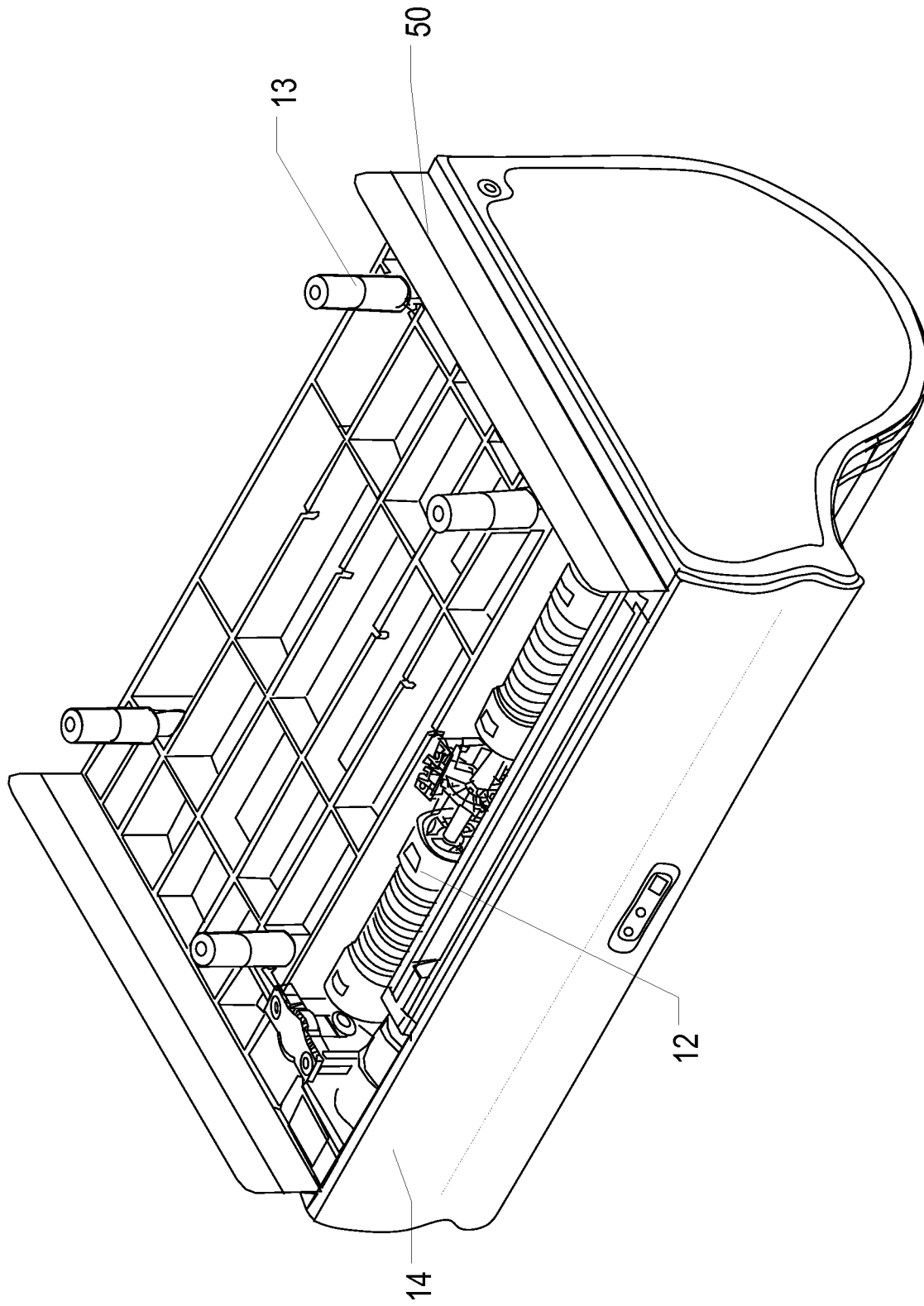

Isometric View

FIG. 22B

*Isometric View with Top Components Removed*

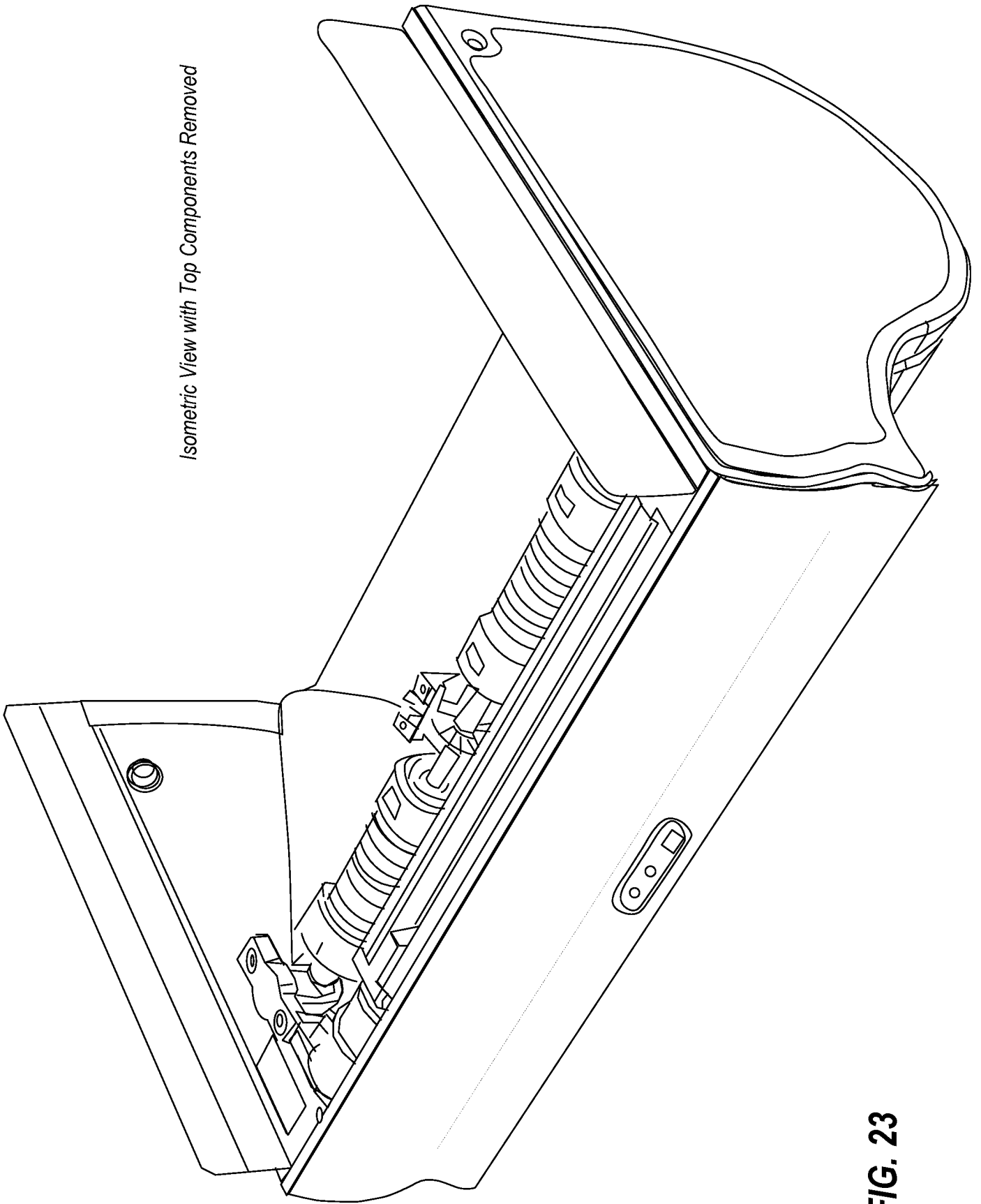

**FIG. 23**

Isometric Exploded View

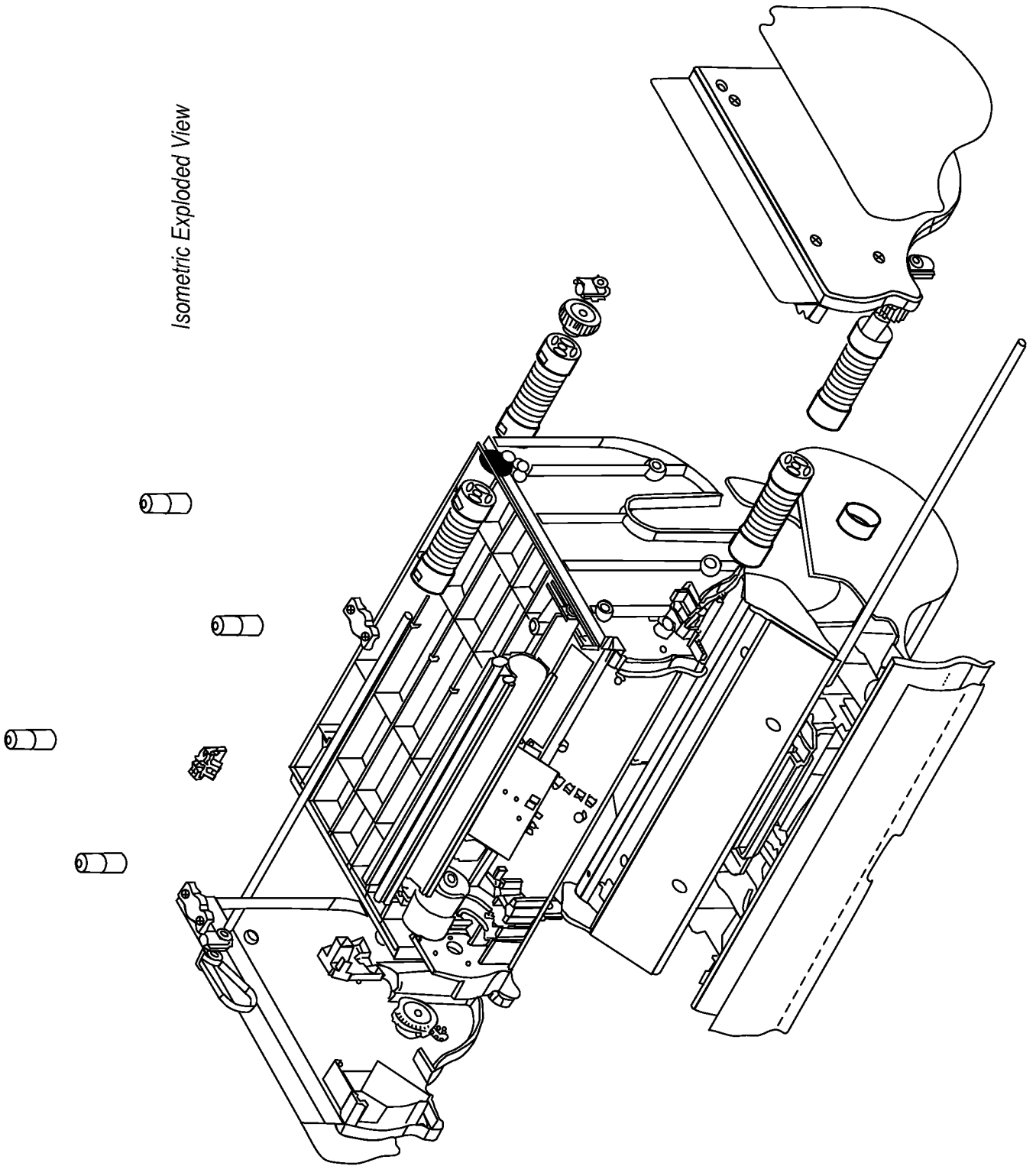

FIG. 24

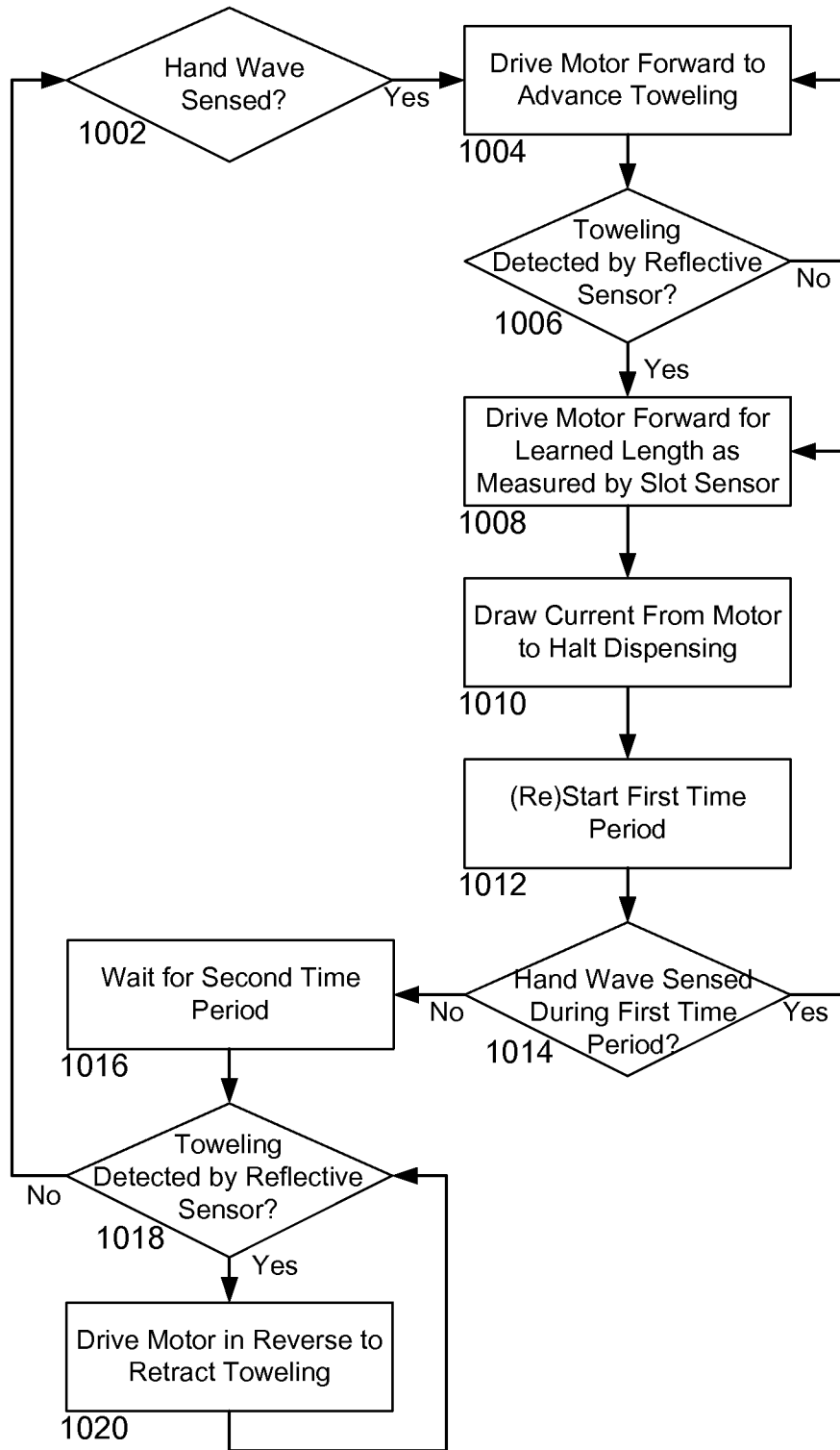

FIG. 25

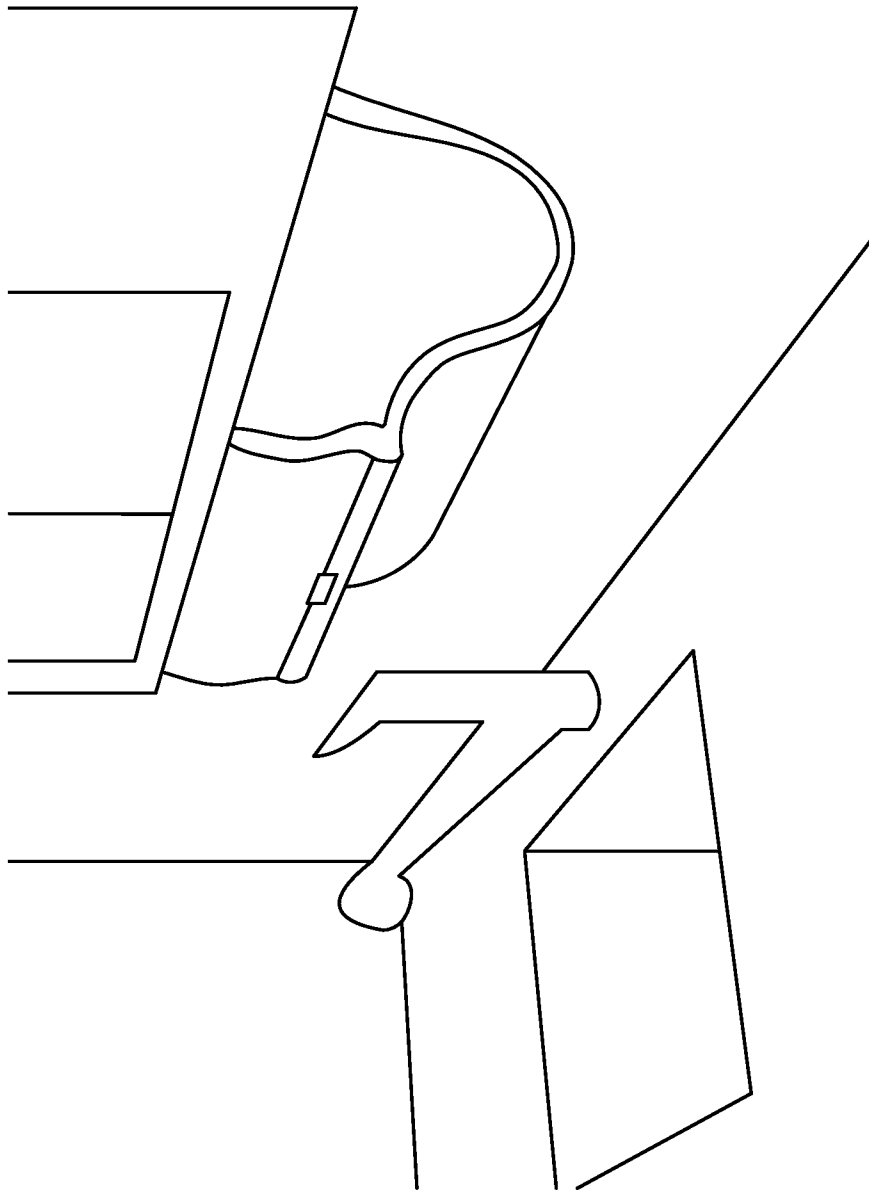

FIG. 26

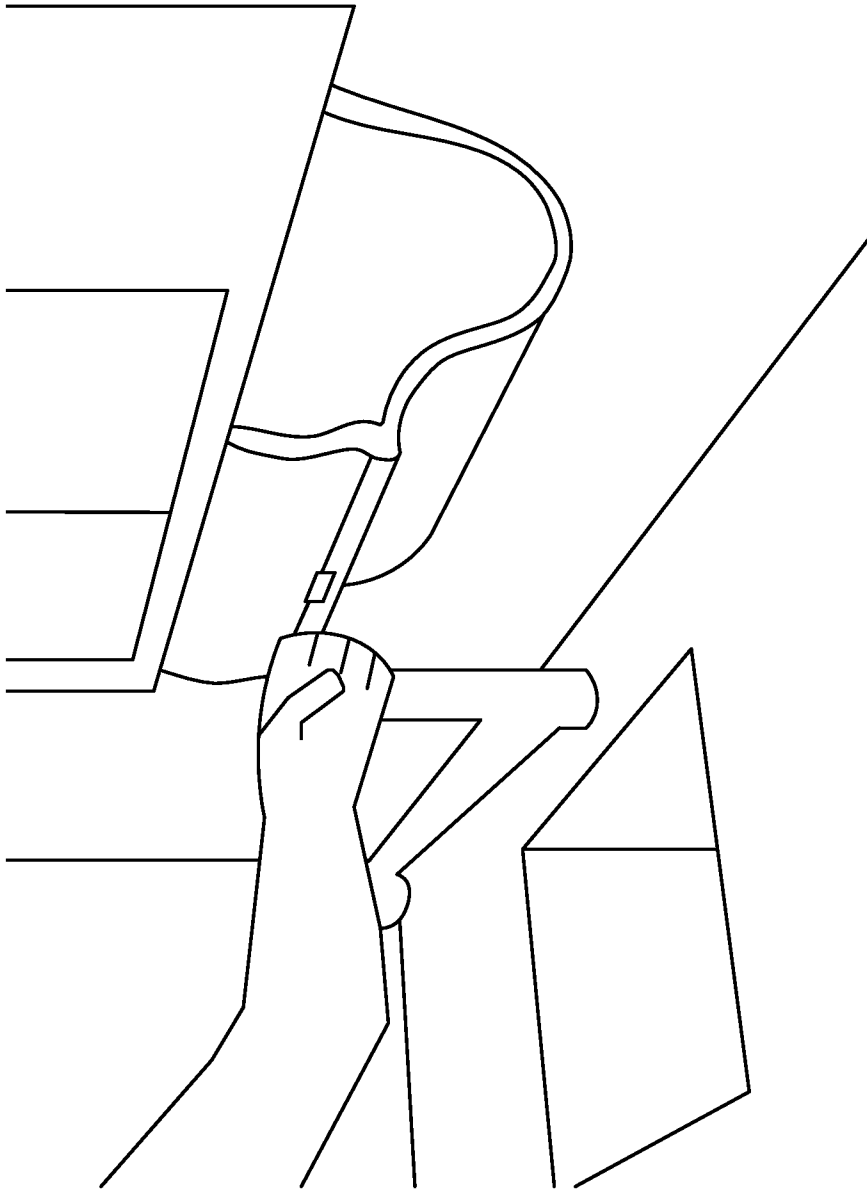

FIG. 27

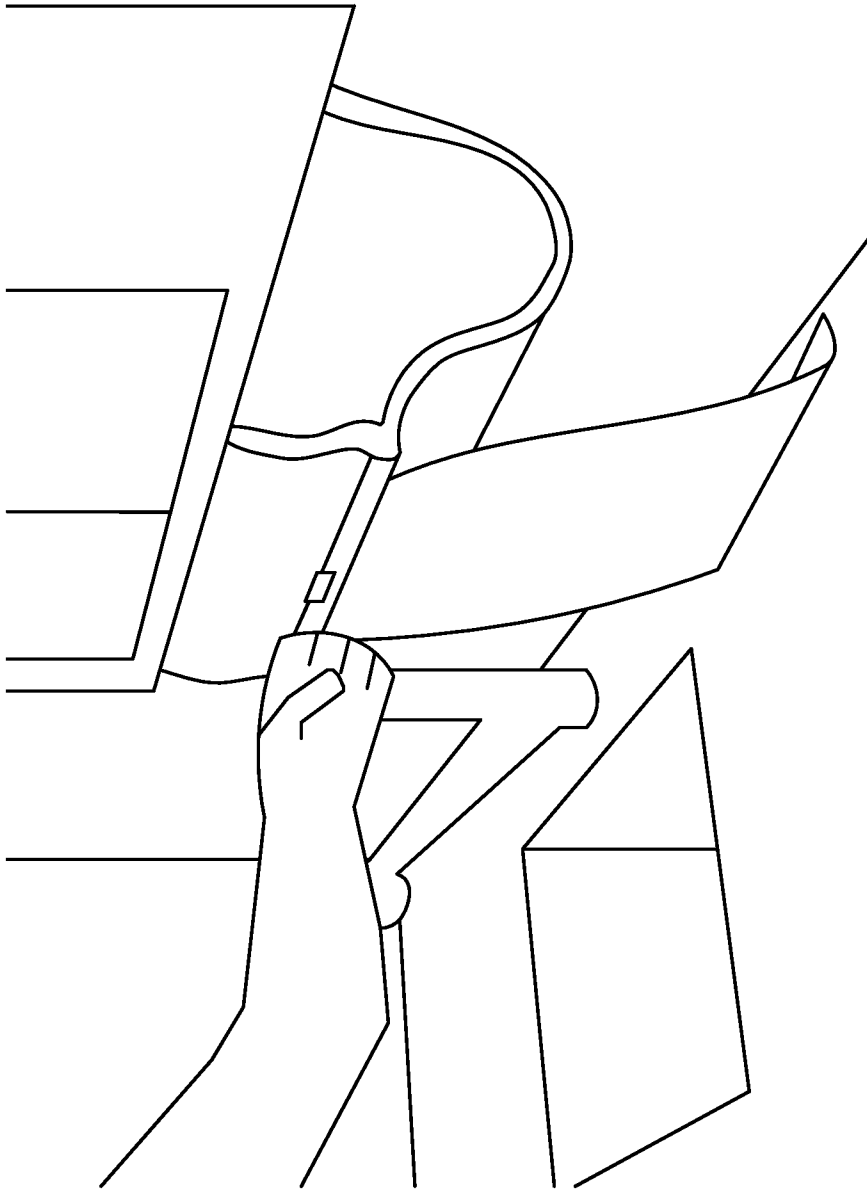

FIG. 28

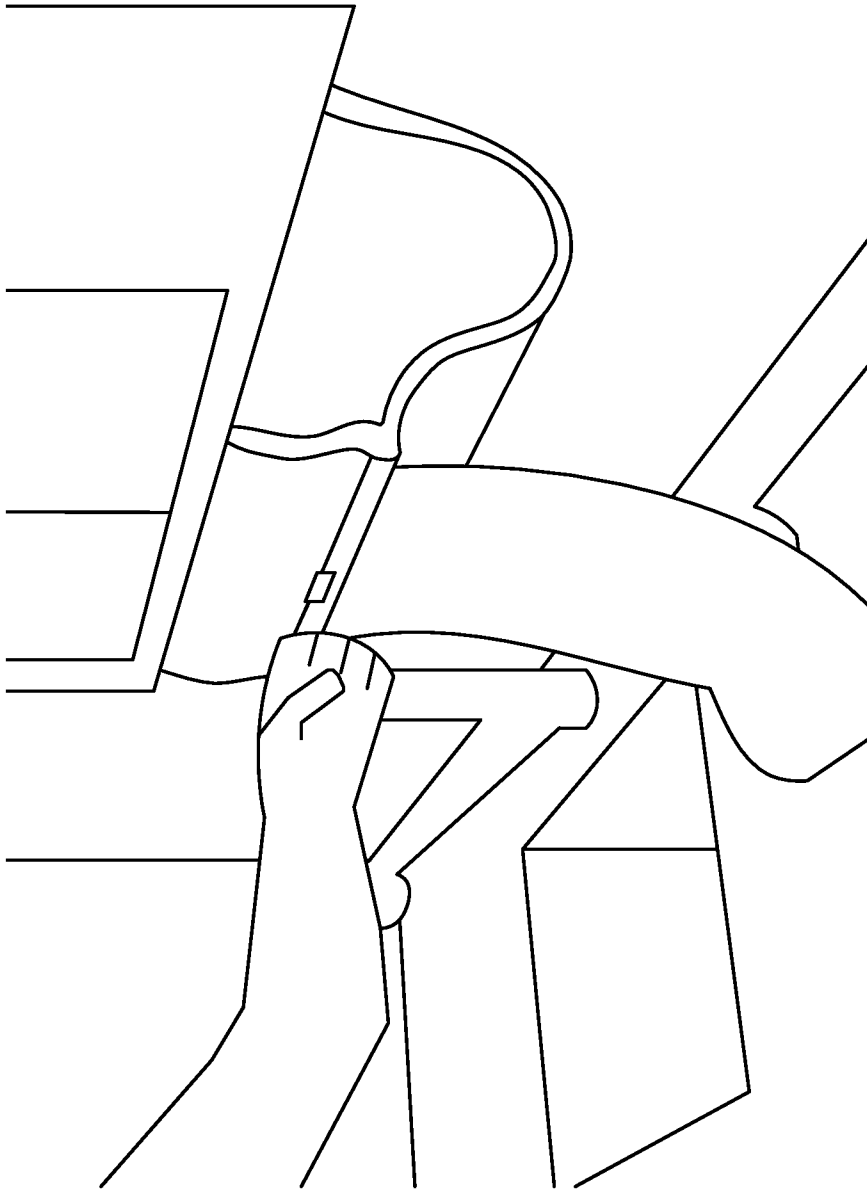

FIG. 29

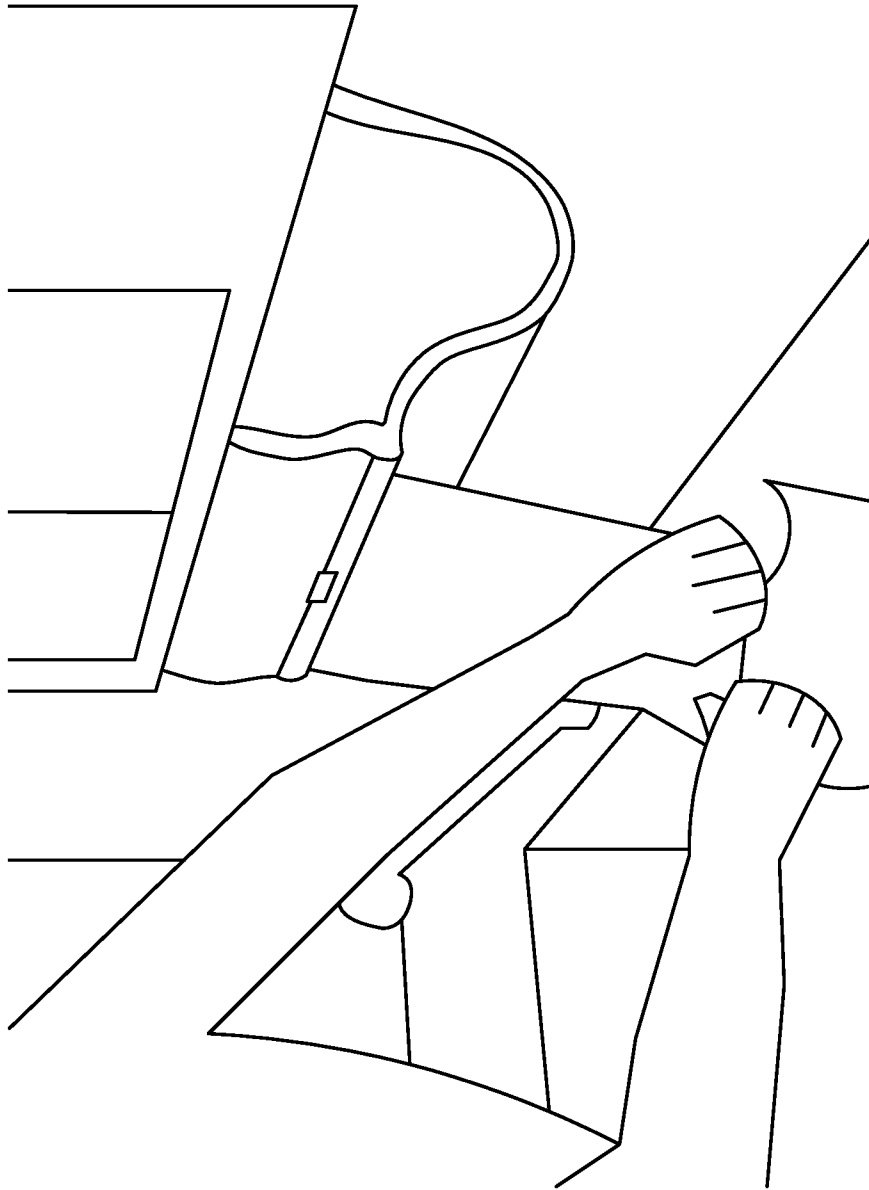

FIG. 30

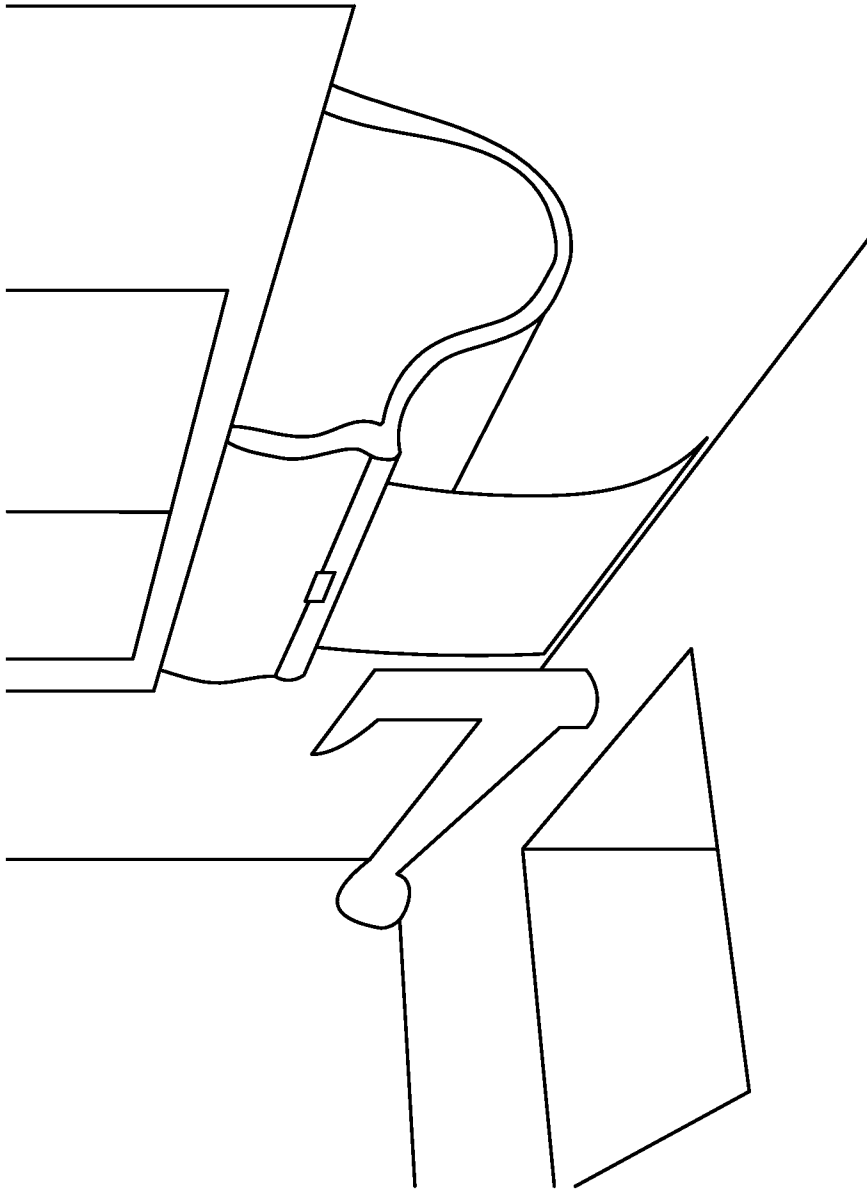

FIG. 31

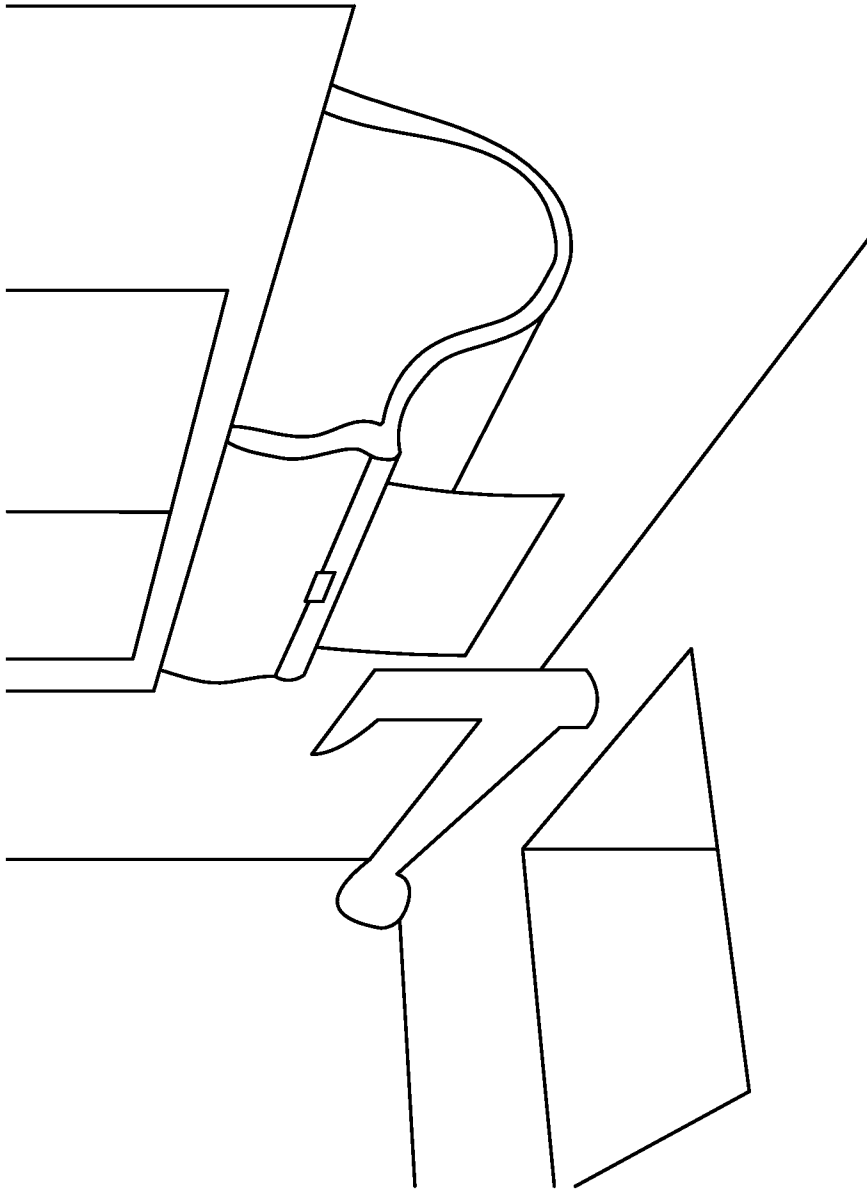

FIG. 32

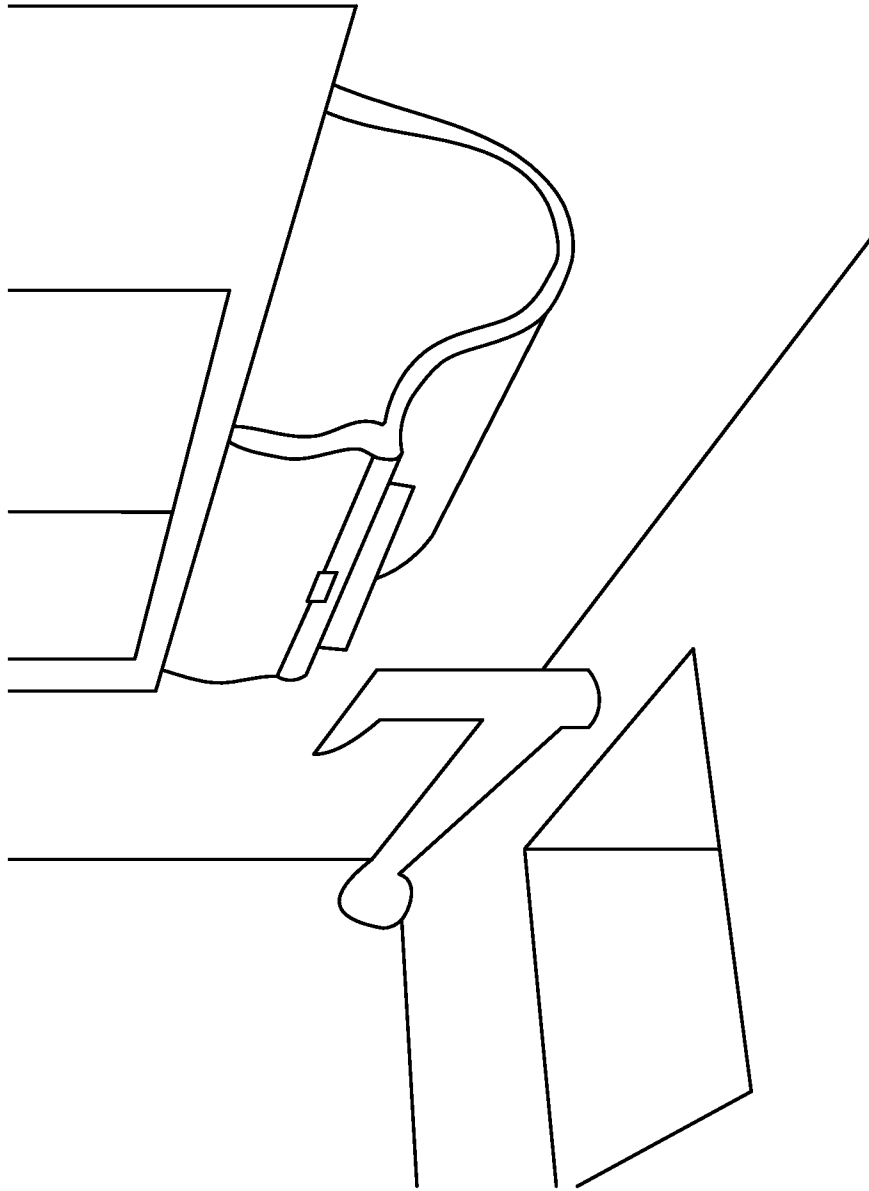

FIG. 33

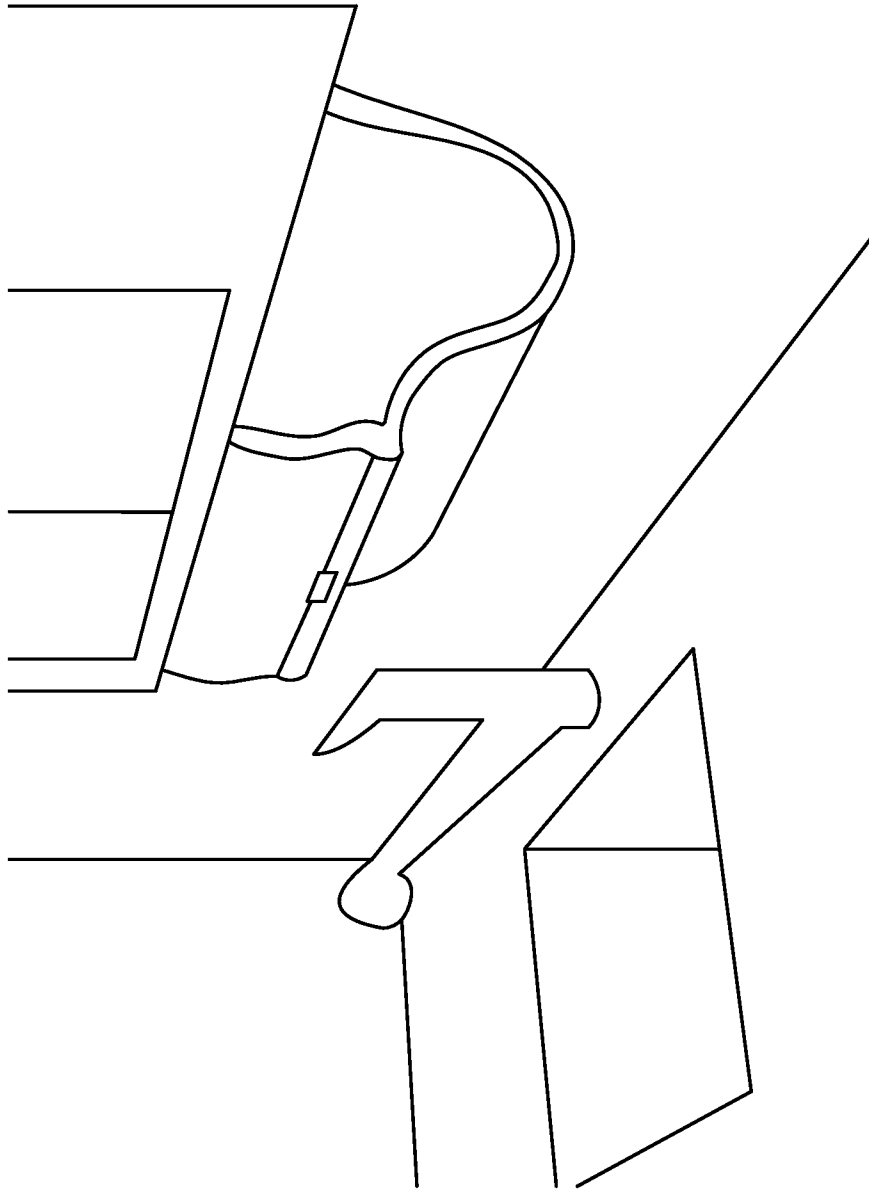

FIG. 34