



(19) **United States**
(12) **Patent Application Publication**
Hopson

(10) **Pub. No.: US 2016/0032677 A1**
(43) **Pub. Date: Feb. 4, 2016**

(54) **GATE VALVE ASSEMBLY COMPRISING A SEALING ASSEMBLY**

(71) Applicant: **FMC TECHNOLOGIES, INC.**,
Houston, TX (US)

(72) Inventor: **Bill Hopson**, Wakefield (GB)

(21) Appl. No.: **14/777,487**

(22) PCT Filed: **Mar. 14, 2014**

(86) PCT No.: **PCT/US2014/029628**

§ 371 (c)(1),

(2) Date: **Sep. 15, 2015**

Related U.S. Application Data

(60) Provisional application No. 61/793,698, filed on Mar. 15, 2013.

Publication Classification

(51) **Int. Cl.**
E21B 33/06 (2006.01)

E21B 33/03 (2006.01)

(52) **U.S. Cl.**
CPC *E21B 33/06* (2013.01); *E21B 33/03* (2013.01)

(57) **ABSTRACT**

A gate valve assembly is provided for shearing an elongated member and controlling a fluid flow through a through bore of the gate valve assembly. The through bore is adapted for fluid communication with a well bore and is configured for receiving an elongated member. The gate valve assembly comprises at least one gate element movably arranged in a direction transverse to the through bore, wherein the gate element is provided with a cutting portion for shearing the elongated member in the through bore. The gate valve assembly further comprises first and second seal seats which are arranged for sealing with the at least one gate element. Further, a seal assembly is provided with at least one sealing surface for sealing with at least one of the first and second seal seats. The seal assembly has activation means for providing an additional sealing force in the engagement between the at least one sealing surface of the seal assembly and at least one of the first and second seal seats. The seal assembly is arranged in a portion of the gate element which is located outside the through bore in an open position of the gate element. The seal assembly is displaceable in the transverse direction into a sealing position when the gate element is in a closed position, wherein the sealing assembly has an activation mode in which the sealing activation means provides additional sealing force to the engagement between the at least one sealing surface of the seal assembly and at least one of the first and second seal seats. The invention also concerns a method for shearing an elongated member arranged in a through bore of a gate valve arrangement and closing the through bore.

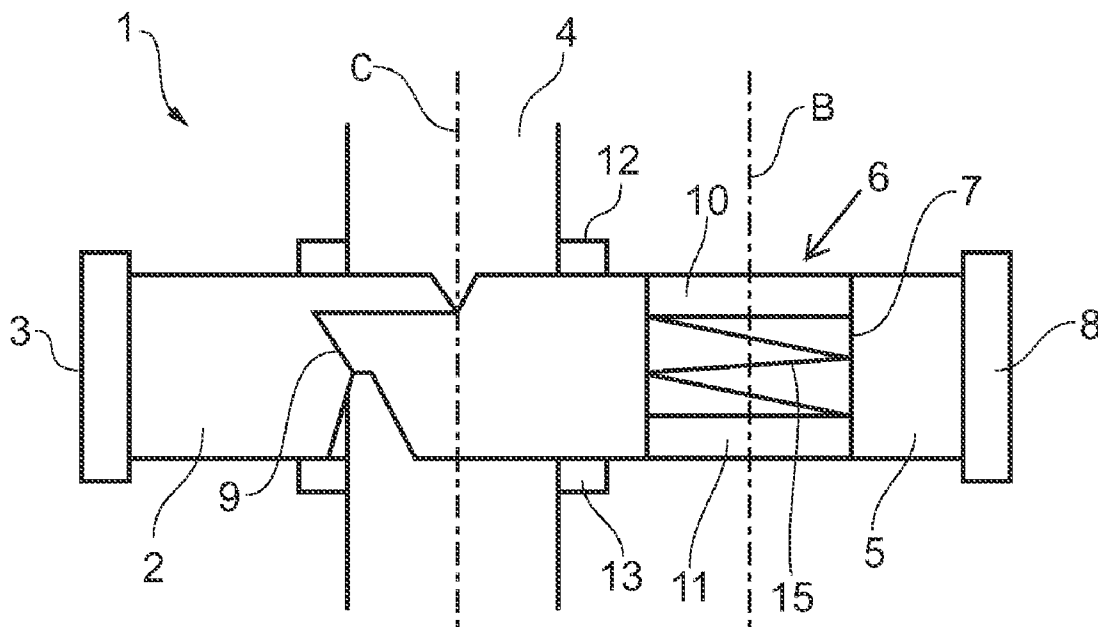

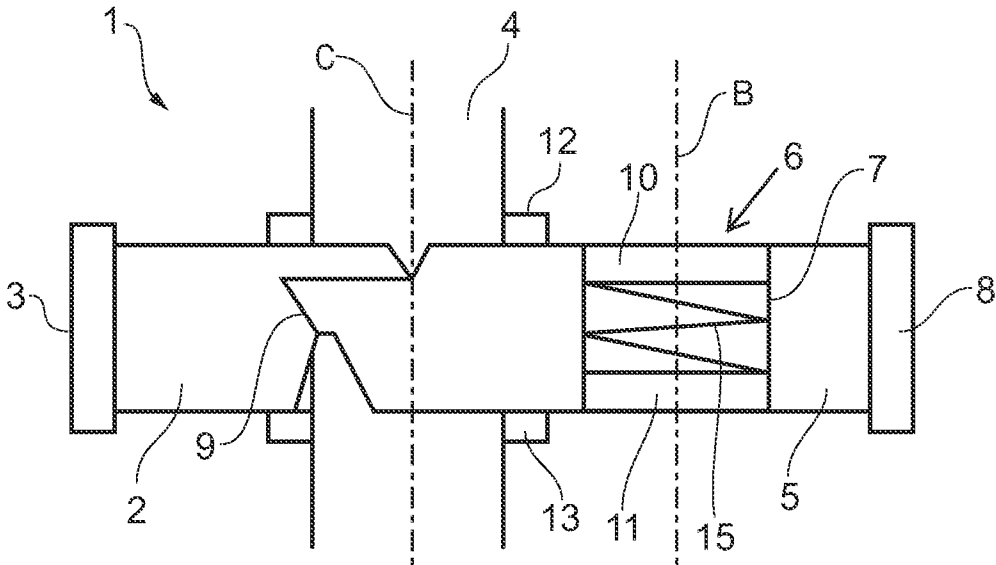

FIG. 1

GATE VALVE ASSEMBLY COMPRISING A SEALING ASSEMBLY

[0001] The invention concerns a gate valve assembly for shearing an elongated member and controlling a fluid flow through a through bore of the gate valve assembly, as well as a method for shearing an elongated member arranged in a through bore of a gate valve arrangement and closing the through bore.

[0002] An elongated member as used in the application described herein includes well related tubular formed elongated members such as a tubing, coned tubing, drill pipes used in work over, drilling, completion, production or intervention operations. The elongated member may also be a wire line or the actual tools to be used when carrying out well related operations.

BACKGROUND OF THE INVENTION

[0003] It is well know within the field to use a safety installment assembly such as for instance a Blow Out Preventer (BOP) or a LRP (lower riser package) in order to avoid a blow out from a well bore when a rapid shut down of the well is necessary, especially in an emergency situation.

[0004] Various kinds of safety installment assemblies on subsea wells are known from the prior art. BOP arrangements normally have a combined operation mode where cutting the tubing or the wire employed in the well first takes place with one element, for instance a ram arrangement, and thereafter closing the well to ensure a sealed closure to avoid fluid leakage of well fluid with another element in the BOP stack.

[0005] As an alternative to a BOP stack with several separate elements, a cutting gate valve arrangement may be used, wherein cutting devices for the cutting of a tubing or a wire line may be included in the gate valve arrangement for shearing of the tubing/wire line prior to closing and sealing the well bore. Such a gate valve arrangement may be provided in various ways. The gate valve arrangement may include one gate valve or plural gate valves. Further the gate valve may comprise a single gate element or plural gate elements for dosing the gate valve.

[0006] In accordance with an established and well practiced solution, the cutting tool of the gate valve is formed at a front edge of the movable gate element of the gate valve, thereby the dosing of the gate valve follows after the cutting of the tube has taken place. However when employing this solution it is necessary to make sure that the actual cutting is to be carried out properly and to ensure that the cut parts of the tubing are properly separated and removed from the dosing area of the gate valve before the dosing of the gate valve takes place. If not, there is a risk that the cut parts of the tubular or wire line will be stuck during the dosing of the gate element, in which case there is no proper dosing of the gate valve and no satisfactory dosing of the well.

[0007] Examples of prior art solutions include U.S. Pat. No. 6,601,650; U.S. Pat. No. 8,353,338; and U.S. Pat. No. 8,567,490.

[0008] U.S. Pat. No. 6,601,650 discloses a valve assembly with gate valves each arranged with a cutting edge at a front portion of the gate element. This publication describes the arrangement of providing the area dose to the gate valve opening with inclined surfaces for moving the sheared pipe parts away from the gate valve before closing the gate valve.

[0009] U.S. Pat. No. 8,353,338 shows two gate valves each with a moveable gate element provided with a cutting edge.

The two gate valves are arranged at each side of the pipe to be sheared and positioned displaced relative to each other as seen in the axial direction of the pipe.

[0010] U.S. Pat. No. 8,567,490 describes the provision of a knife edge at the gate element of the gate valve in order to obtain a dean cut when cutting the tube, This publication also describes the arrangement of spring elements to enhance the sealing force when dosing the gate valve.

[0011] An objective of the invention is to provide a gate valve arrangement which obtains an efficient shearing of the elongated member in order to make sure that the gate valve is properly dosed for dosing and sealing of the well bore.

[0012] A further objective is to ensure that the cutting process is properly completed before the dosing and sealing of the gate valve arrangement is carried out.

[0013] Another objective of the invention is to provide a gate valve arrangement with a compact construction, reliable working principles and a simple operation. It is desirable to provide a gate valve arrangement which ensures that the cutting operation has been carried out efficiently before the closing of the gate valve is conducted in order to avoid the problems as described above.

[0014] Another objective is to ensure the integrity of the sealing function of the gate valve.

SUMMARY OF THE INVENTION

[0015] The invention is set forth and characterized in the independent claims, while the dependent claims describe other characteristics of the invention.

[0016] The invention concerns a gate valve assembly for shearing an elongated member and controlling a fluid flow through a through bore of the gate valve assembly. The through bore is adapted for fluid communication with a well bore and is configured for receiving an elongated member. The gate valve assembly comprises at least one gate element movably arranged in a direction transverse to the through bore, wherein the gate element is provided with a cutting portion for shearing the elongated member in the through bore. Further, the gate valve assembly is provided with first and second seal seats arranged for sealing the at least one gate element. The gate valve assembly further comprises a seal assembly provided with at least one sealing surface for sealing with at least one of the first and second seal seats. The seal assembly has activation means providing additional sealing force in the engagement between the sealing surface of the seal assembly and at least one of the first and second seal seats. The seal assembly is arranged in a portion of the gate element which is located outside the through bore in an open position of the gate element, and the seal assembly is arranged displaceably in the transverse direction into a sealing position when the gate element is in a closed position. The sealing activation means has an activation mode arranged to provide additional sealing force to the engagement between the at least one sealing surface of the seal assembly and at least one of the first and second seal seats.

[0017] In accordance with the invention, the seal assembly is arranged displaceably in the transverse direction into a sealing position when the gate element is in a closed position. The seal assembly may be arranged to follow the movement of the gate element, to displace the seal assembly into sealing position when the gate element is in the closed position.

[0018] In an embodiment of the valve assembly, the seal assembly may be arranged in a recess in the gate element. In accordance with this embodiment, the seal assembly may

follow the movement of the gate element and displace the seal assembly into sealing position when moving the gate element into the closed position. The movement of the gate element may thereby position the seal assembly in a position where the sealing activation means may be activated for providing additional sealing force between the at least one sealing surface of the seal assembly and at least one of the first and second seal seats.

[0019] The seal assembly may be arranged for displacement between an initial position in a transverse bore outside the through bore and the sealing position in the through bore.

[0020] The recess for arrangement of the seal assembly may have various configurations. The recess may be arranged for accommodation of the seal assembly in the initial position, positioning the at least one sealing surface essentially in line with one of the surfaces of the gate element facing the first or second seal seats. Or, the recess may be arranged for accommodation of the seal assembly in the initial position, positioning one sealing surface essentially in line with one surface of the gate element facing the first seal seat and the other sealing surface in line with the other surface facing the second seal seat. When the sealing surface(s) is/are essentially in line with the surface of the gate element facing the seal seats, the gate valve assembly is configured for a smooth dosing of the gate element.

[0021] In an embodiment of the valve assembly, the seal assembly may in addition to the activation mode have an initial mode. The seal assembly in the initial mode may be arranged so that no additional sealing force is provided. The seal assembly may be provided by control means arranged for shifting the seal assembly between the initial mode and the activation mode. The seal assembly may thus be configured so that the control means controls the shifting into the activation mode when the seal assembly is in sealing position, and thus provides additional sealing force in engagement with the at least one of the sealing surface of the seal assembly and at least one of the first and second seal seats.

[0022] In an embodiment of the valve assembly, at least one of the first and second seal seats may be arranged as sealing activator means causing the activation mode of the seal assembly. In accordance with this embodiment the seal assembly in contact with at least one of the seal seats causes the seal assembly to shift into the activation mode, thereby providing additional sealing force in engagement with the at least one of the sealing surface of the seal assembly and at least one of the first and second seal seats. The at least one of the first and second seal seats may be provided as sealing activator means in addition or as an alternative to the use of control means to control the shifting between the initial mode and the activation mode.

[0023] In an embodiment of the valve assembly the sealing activation means may comprise compressible means, for instance elastic compressible means. In the initial mode of the seal assembly, the compressible means may be arranged in a compressed state, and in the activation mode the compressible means may have a releasing state, thus being arranged to provide an additional sealing force to the first and/or second seal seat. If the sealing activation means comprises a spring element, the spring element may be positioned in a recess in a compressed state by suitable means until being positioned in sealing position wherein the spring will be released from the compressed state, providing an additional sealing force in

engagement between the at least one sealing surface of the seal assembly and at least one of the first and second seal seats.

[0024] The sealing activation means may comprise any means capable of providing an additional sealing force to the engagement between the at least one sealing surface of the seal assembly and at least one of the first and second seal seats, for instance mechanical structures, mechanical arrangements or fluid activated means.

[0025] As described above, the activation means may comprise compressible means. The compressible means may be in a compressed state before positioned in the sealing position or the compressible means may be brought into a compressed state in the sealing position, in order to provide additional sealing force to the engagement between the at least one sealing surface of the seal assembly and at least one of the first and second seal seats. In the initial mode of the seal assembly the axial extension of the seal assembly may correspond to the distance between the first and second seal seat, thereby providing for the insert of the seal assembly between the first and second seal seat. The seal assembly may be inserted between the first and second seal seat in an initial mode. The shifting into the activation mode may thus occur as described above by the use of control means.

[0026] In an embodiment of the invention, the gate valve assembly may comprise two gate elements provided for the shearing of the elongated member. Subsequently to the shearing of the elongated member, the first gate element and the second gate element may have an interconnection position for connection of the first and second gate elements. The interconnection may be arranged by suitable locking means.

[0027] In an embodiment of the gate valve assembly, the interconnection position of the first and second gate elements may be arranged as a gate element unit movably arranged between the interconnection position and the through bore dosing position where the seal assembly is arranged in a sealing position. By the interconnection of the first and second gate element, a gate element unit for guiding the seal assembly into the proper sealing position is obtained as the interconnected first and second gate is accommodated in the transverse bore at each side of the through bore ensuring a stable an accurate displacement of the seal assembly into sealing position.

[0028] In an embodiment of the gate valve assembly, the first gate element and the second gate element may be movably arranged in opposite directions between an initial shearing position and a completed shearing position for the shearing of the elongated member. The first gate element may be arranged to first move into an initial shearing position shearing the elongated member from one side, and then the second gate element conducts shearing from the other side, wherein the first and second gate elements are prepared to be interconnected when the shearing is completed and the first and second gate element are positioned in the completed shearing position.

[0029] The gate valve assembly may be provided with release means for removing the seal assembly from the sealing position.

[0030] The invention also comprises a method for shearing an elongated member arranged in a through bore of a gate valve arrangement and for closing the through bore. The through bore is adapted for fluid communication with a well bore. An elongated member is arranged in the through bore and the method comprises the following steps: moving at

least one gate element in contact with first and second seal seats in a direction transverse to the through bore and into the through bore for the shearing of the elongated member; and closing the through bore by moving at least one gate element arranged with a seal assembly provided with at least one sealing surface for sealing with at least one of the first and second seal seats, thereby moving the seal assembly in the transverse direction and causing an activation of sealing activation means which are arranged in the seal assembly for providing additional sealing force to the engagement between the at least one sealing surface of the seal assembly and at least one of the first and second seal seats.

[0031] In an embodiment of the method in accordance with the invention, the method comprises the following steps:

[0032] moving a first gate element into a first shearing position in engagement with the elongated member;

[0033] moving a second gate element into a second shearing position in engagement with the elongated member and completing the shearing of the elongated member by the first and second gate elements;

[0034] interconnecting the first and second gate elements;

[0035] moving the interconnected first and second gate elements for the closing of the through bore; thereby

[0036] closing the through bore by moving the interconnected first and second gate elements, wherein the first or the second gate element is arranged with the seal assembly having at least one sealing surface for sealing with at least one of the first and second seal seats, thereby moving the seal assembly in the transverse direction and causing an activation of the sealing activation means of the seal assembly to provide additional sealing force to the engagement between the sealing surfaces of the seal assembly and the first and second seals.

[0037] These and other characteristics of the invention will be explained in more detail with reference to the attached drawings showing a non-restrictive example.

BRIEF DESCRIPTION OF THE DRAWINGS

[0038] FIG. 1 is a side section view of a first embodiment of the gate valve arrangement of the present invention.

DETAILED DESCRIPTION OF THE INVENTION

[0039] FIG. 1 shows a gate valve assembly 1 comprising a first gate element 2 arranged to be moved in a direction transverse to a through bore 4 by a first actuator 3. A second gate element 5 is provided with a seal assembly 6 in a recess 7 and is arranged to be moved in a direction transverse to the through bore 4 by a second actuator 8. The gate elements 2 and 5 are arranged to move in opposite directions and each is provided with a cutting portion 9, which in FIG. 1 is visible only on the second gate element 5. The first gate element 2 is moved into the through bore 4 and starts shearing until the gate element reaches a shearing position at the centerline C. The second gate element 5 then starts the shearing from the opposite side of the elongated member by moving the second gate element 5 towards the first gate element 2 in order to complete the shearing process.

[0040] The first and second gate elements 2, 5 are configured to interconnect to each other after completing the shearing of the elongated member, and suitable locking means are provided in order to lock the gate elements together. The interconnected gate elements 2, 5 then move the seal assembly

6 in the transverse direction into a sealing position. This displacement of the seal assembly 6 is illustrated in FIG. 1 by lines B and C. Line B coincides with line C when the seal assembly 6 is displaced into the sealing position.

[0041] The seal assembly 6 has seal surfaces such as a first sealing surface 10 to be arranged in sealing engagement with the first seal seat 12, and a second sealing surface 11 to be arranged in sealing engagement with the second seal seat 13.

[0042] The seal assembly 6 is also provided with sealing activation means 15 arranged to provide an additional sealing force in engagement with the first and second seal seats 12, 13. In FIG. 1 the sealing activation means 15 is shown as compressible means having an initial mode in which the compressible means is in a compressed state in an initial position outside the through bore 4 indicated by line B.

[0043] When moving the interconnected gate elements 2 and 5 and thereby displacing the seal assembly 6 into a position where line B coincides with line C, the seal assembly is arranged in the sealing position and the sealing activation means 15 is activated into a releasing mode to provide an additional sealing force between the seal assembly 6 and the first and second seal seats 12, 13. This activation of the sealing activation means 15 in order to achieve additional sealing may be provided in various ways. For instance, the seal assembly 6 may be provided with control means arranged for shifting the seal assembly between the initial mode and the activation mode. The control means may be provided so that the sealing activation means 15 is held in the compressed state before being placed into sealing position between the seal seats 12, 13. The control means may be provided by devices arranged internally in the seal element to make sure the seal assembly is held in the compressed state until being arranged in the sealing position, where line B coincides with line C. When arranged in the sealing position, the sealing activation means 15 is brought into activation mode, for instance by the control means. With the activation means 15 being provided by compressible elastic means such as spring means, the seal assembly 6 will then be displaced into the sealing position in a preloaded condition and brought into a releasing state providing additional sealing force between the seal seats 12, 13 and the seal surfaces 10, 11 of the seal assembly 6.

[0044] Alternatively or in addition to the arrangement described above, the seal seats 12, 13 and/or the seal assembly may be provided with sealing activator means for causing the activation of the activation means in the sealing.

[0045] A person skilled in the art will understand that there may be made alterations and modifications to the embodiments that are within the scope of the invention as defined in the attached claims, and elements or features of the different embodiments may be combined in any configuration.

1: A gate valve assembly for shearing an elongated member and controlling a fluid flow through a through bore of the gate valve assembly, the through bore being adapted for fluid communication with a well bore and is configured for receiving the elongated member, the gate valve assembly comprising:

at least one gate element movably arranged in a direction transverse to the through bore, wherein the gate element is provided with a cutting portion for shearing the elongated member in the through bore;

first and second seal seats between which the gate element is positioned the first and second seal seats be n configured for sealing with the at least one gate element;

a seal assembly provided with at least one sealing surface for sealing with at least one of the first and second seal seats, wherein the seal assembly comprising sealing activation means for providing additional sealing force in the engagement between the at least one sealing surface of the seal assembly and at least one of the first and second seal seats;

wherein the seal assembly is arranged in a portion of the gate element which is located outside the through bore in an open position of the gate element and is displaceable in the transverse direction into a sealing position across the through bore when the gate element is in a closed position, and wherein in an activation mode of the sealing assembly the sealing activation means provides the additional sealing force in the engagement between the at least one sealing surface of the seal assembly and at least one of the first and second seats.

2: The gate valve assembly in accordance with claim 1, wherein the seal assembly is arranged in a recess in the gate element.

3: The gate valve assembly in accordance with claim 1, wherein the seal assembly is arranged for displacement between an initial position located in a transverse bore outside the through bore and the sealing position located across the through bore.

4: The gate valve assembly in accordance with one of the preceding claims claim 1, wherein in an initial mode of the sealing assembly the sealing activation means provides no additional sealing force in the engagement between the at least one sealing surface of the seal assembly and at least one of the first and second seats.

5: The gate valve assembly in accordance with claim 1, wherein at least one of the first or second seal seats is configured for causing the activation mode of the seal assembly.

6: The gate valve assembly in accordance with claim 4, wherein the sealing activation means comprises compressible means, and wherein in the initial mode the compressible means is arranged in a compressed state and in the activation mode the compressible means is arranged in a released state.

7: The gate valve assembly in accordance with claim 6, wherein the seal assembly is provided with control means for shifting the seal assembly between the initial mode and the activation mode.

8: The gate valve assembly in accordance with claim 1, wherein the gate valve assembly comprises a second gate element for the shearing of the elongated member, and wherein the first and second gate elements have an interconnection position in which the first and second gate elements are connected to each other subsequently to the shearing of the elongated member.

9: The gate valve assembly in accordance with claim 8, wherein the first and second gate elements are movable in opposite directions between an initial shearing position and a completed shearing position.

10: The gate valve assembly in accordance with claim 8, wherein in the interconnection position, the first and second gate elements are arranged as a gate element unit which is movable between the interconnection position and a through bore dosing position in which the at least one sealing surface of the seal assembly is arranged for sealing with at least one of the first and second seal seats.

11: The gate valve assembly in accordance with claim 1, further comprising release means for removing the seal assembly from the sealing position.

12: A method for shearing an elongated member positioned in a through bore of a gate valve arrangement and dosing the through bore, the through bore being adapted for fluid communication with a well bore, the method comprising the steps of:

- moving at least one gate element between first and second seal seats in a direction transverse to the through bore for the shearing of the elongated member, said at least one gate element comprising a seal assembly provided with at least one sealing surface for sealing with at least one of the first and second seal seats;

- closing the through bore by moving the at least one gate element to thereby position the least one sealing surface into engagement with at least one of the first and second seal seats; and

- providing additional sealing force to the engagement between the at least one sealing surface of the seal assembly and at the least one of the first and second seal seats.

13: The method in accordance with claim 12, comprising the following steps:

- moving a first gate element into a first shearing position in engagement with the elongated member;
- moving a second gate element into a second shearing position in engagement with the elongated member and completing the shearing of the elongated member by the first and second gate elements;
- interconnecting the first and second gate elements;
- moving the interconnected first and second gate elements for the closing of the through bore; and
- closing the through bore by moving the interconnected first and second gate elements;

wherein one of the first and second gate elements comprises said at least one gate element which is arranged with the seal assembly.

* * * * *