

J. S. CLARKE.
 STEERING APPARATUS FOR VESSELS.
 APPLICATION FILED MAY 31, 1910.

998,158.

Patented July 18, 1911.

2 SHEETS—SHEET 1.

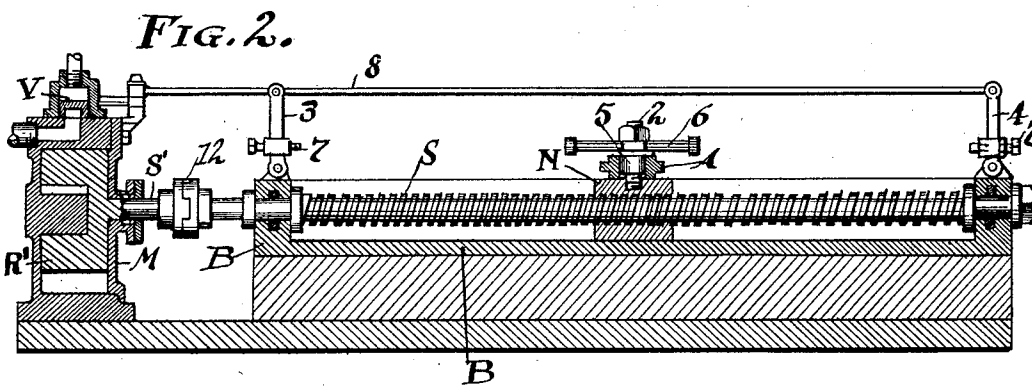
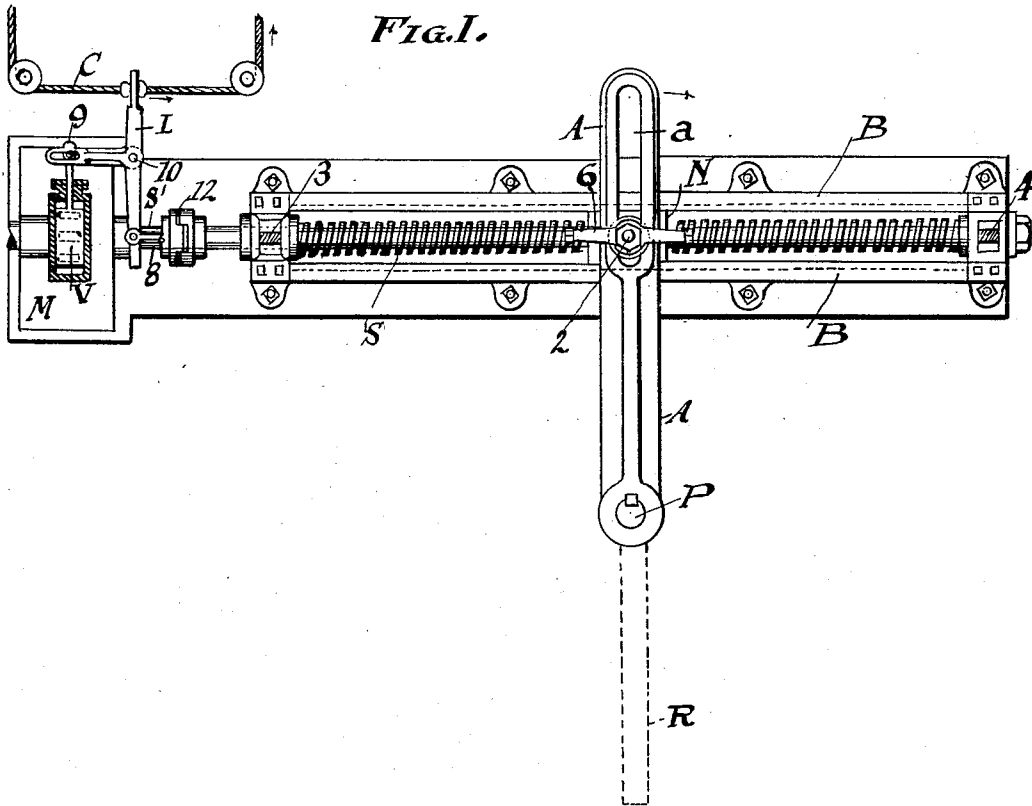

ATTEST
E. W. Fisher
H. S. Knapp

INVENTOR
 JOHN S. CLARKE
 BY *Fisher & Knapp* ATTYS.

J. S. CLARKE.
 STEERING APPARATUS FOR VESSELS.
 APPLICATION FILED MAY 31, 1910.

998,158.

Patented July 18, 1911.

2 SHEETS—SHEET 2.

FIG. 3.

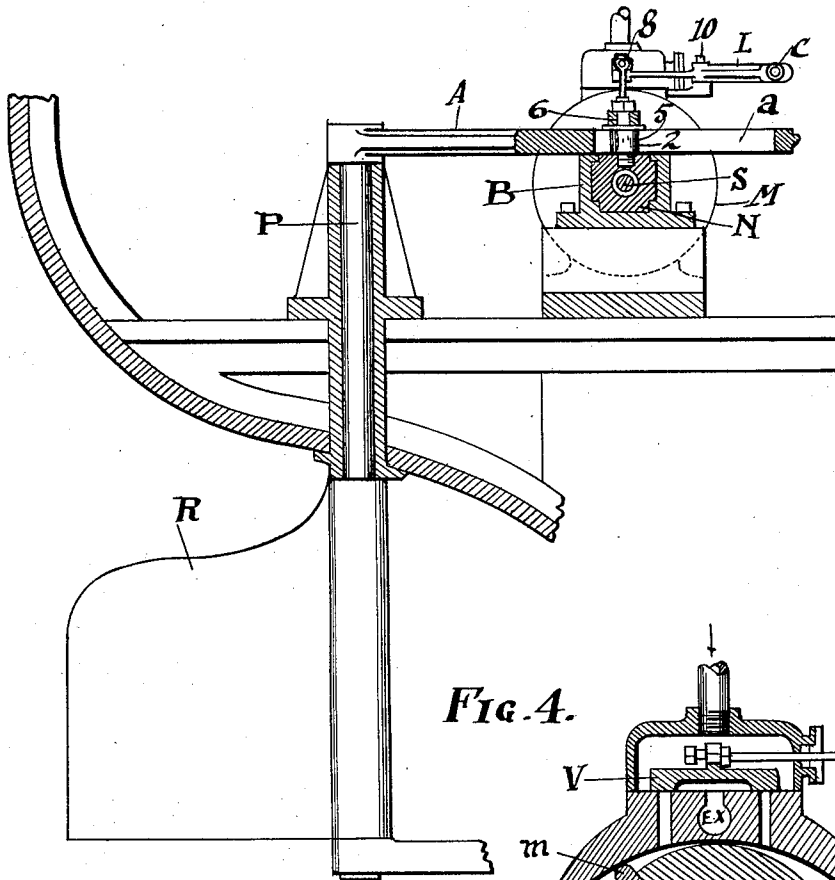
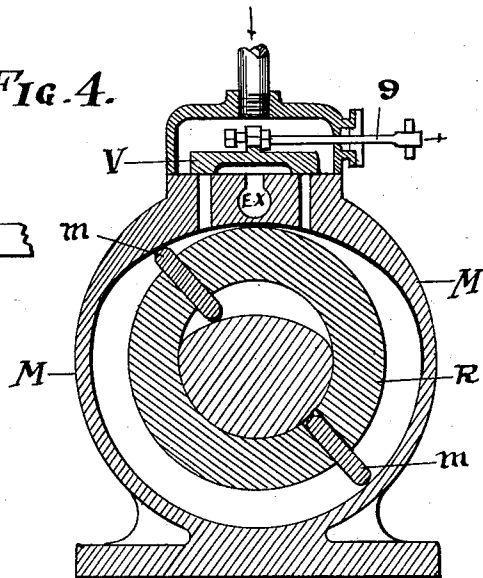

FIG. 4.



ATTEST
E. M. Fisher
H. H. Knapp

INVENTOR
 JOHN S. CLARKE.

BY *Fisher & Moore* ATTYS.

UNITED STATES PATENT OFFICE.

JOHN S. CLARKE, OF EAST CLEVELAND, OHIO, ASSIGNOR, BY DIRECT AND MESNE ASSIGNMENTS, OF ONE-THIRD TO ALEXANDER H. LANGELL AND ONE-THIRD TO C. R. WEDLER, BOTH OF CLEVELAND, OHIO.

STEERING APPARATUS FOR VESSELS.

998,158.

Specification of Letters Patent.

Patented July 18, 1911.

Application filed May 31, 1910. Serial No. 564,058.

To all whom it may concern:

Be it known that I, JOHN S. CLARKE, citizen of the United States, residing at East Cleveland, in the county of Cuyahoga and State of Ohio, have invented certain new and useful Improvements in Steering Apparatus for Vessels, of which the following is a specification.

My invention relates to steering apparatus for vessels, and the invention consists in an apparatus having a power engine which controls the steering mechanism directly by power and means for controlling the engine by the pilot or man at the steering wheel, all substantially as shown and described and particularly pointed out in the claims.

In the accompanying drawings, Figure 1 is a plan view of the invention, and Fig. 2 is a longitudinal sectional elevation of the rudder and controlling arm therefor and other details. Fig. 3 is a side view in vertical section of the said mechanism as it is associated with the rudder, and Fig. 4 is a cross section of the engine.

The foregoing embodiment entirely relieves the man at the steering wheel from the burden of operating the rudder as the rudder is mechanically connected with the engine or motor and which in turn is controlled or operated by the wheelman through the valves which govern the admission and exhaust of steam to the engine. This makes the work of steering easy and brings it under reliable control.

Of course I am aware that in its broader sense an engine operated rudder is not entirely new, and particularly one that is operated by an electric motor, but such use necessarily involves the installation of a special and expensive electrical equipment upon the vessel in addition to steam for running the vessel with the contingent objection that if anything should go wrong with any part of the electrical machinery or connections the boat would be paralyzed and helpless until repaired. This objection is entirely overcome in the use of a steam motor because it is connected up by fixed pipes directly with the steam boilers of the vessel, and the motor itself is as reliable as the engines of the vessel and always ready to work when the engines are ready and can therefore be positively relied upon at all times and under all conditions of service

when the vessel is under steam. Preferably the motor employed in my system is a steam rotor or rotary steam motor, and the power is communicated therefrom directly to the steering mechanism which controls the rudder.

Now, having reference to the drawings, R represents the rudder of the vessel and A the arm or lever by which the rudder is controlled, the same being rigidly fixed upon the rudder post P. Power is conveyed from the motor M to the said arm and the rudder is operated by means of a screw shaft S, which is also the motor shaft, and which is operatively inclosed for the most part in or by a trough or box B. A nut N shaped substantially to the cross section of the box is threaded on the said screw in box B and operatively engaged with arm A through slot *a* therein by means of a headed screw or pin 2 with a head outside and fixed in said nut. The said trough is of a length to accommodate the sweep of arm A and the travel of nut N the full length of slot *a* and preferably is rectangular in cross section, serving as a support and guide for said nut. To this end also the nut is made square and of a size to run freely in said trough but not to turn therein, and the trough is made oil tight and more or less filled with oil to lubricate the screw and promote easy operations. The said trough is shown also as carrying vertically disposed arms 3 and 4, respectively, pivoted on its ends and which are in line with the travel of nut N. The said nut carries the stem 2 on which is mounted a roller 5 running in slot *a* and above this a push bar 6 fixed at its middle on said pin or screw 2 and in alinement with the set screws 7 on said arms 3 and 4, so that when the nut N has run to either end of its travel it will automatically shut off the motor by contacting the corresponding end of bar 6 with the screw 7 on the arm 3 or 4 at that end, the travel in any case being far enough to effect the complete cut-off of steam to the motor by slide valve V. Said valve is reached by a rod 8, or its equivalent, which connects the ends of arms 3 and 4 indirectly with the valve stem 9 and which operates to close off the steam at the maximum stroke of the arm A in either sweep of the arm as above described. The wheelman, therefore, has nothing whatever to do

directly with the rudder R but rather with the cord or cable C which controls T shaped lever L and which in turn has the rod S connected with its opposite arm and is pivoted at 10 in its angle. This pivot also gives the pilot complete control of valve V independently of all other mechanism and through which mechanism he can reverse the motor or slow it down or stop it altogether and thus lock the rudder. In fact the most perfect rudder control is afforded the pilot by these means, as must be obvious. Of course with a high speed motor with say about one thousand revolutions per minute and a screw S with a fairly quick pitch the throw of lever or arm A of the rudder must necessarily be quick and effective and adapted to turn the rudder either way more or less or hold it to a given course without the exercise of any personal strength beyond what little may be required to shift an easily operated motor controlling valve.

The screw S is suitably packed at each end of the box B to prevent leakage, and screw shaft S has a coupling connection 12 outside said box with the short shaft S' of the motor. This makes an interlocked working connection in which any looseness of play in either shaft is absorbed in said coupling and is not communicated beyond.

The rotor R' is eccentrically mounted in the motor casing and has two blades *m* in this instance. Any suitably constructed motor may be used.

What I claim is:

1. An apparatus for steering vessels comprising a trough adapted to be more or less filled with oil, a screw shaft having bearings in the ends thereof and a nut on said shaft adapted to run in said trough as the shaft is rotated, in combination with power operat-

ing means coupled with one end of said shaft, pivotally supported arms on the ends of said trough and a rod connection said arms operatively connected with a valve and means on said nut to tilt said arms and thereby cause said valve to be shifted.

2. In a steering apparatus for vessels, power operating means and a screw shaft operatively connected therewith, a trough for said shaft and a nut operatively engaging the wall thereof and adapted to travel lengthwise on said shaft, a pivoted arm upon each end of said box and a rod connecting said arms and having one end in operating relation to said power operating means.

3. The combination of a rudder for a vessel and an arm to control the same, a rotatable screw and a nut mounted thereon with which said arm has slidable engagement, in combination with a rotary steam engine operatively coupled to one end of said shaft, a valve for said engine and a slotted lever connected with said valve and a cable operatively engaged with said lever.

4. Means for controlling rudders in vessels comprising a screw shaft and power means to turn the same, a trough in which said shaft is mounted and a traveling nut mounted on said shaft, in combination with arms pivoted on the ends of said trough and a rod connecting the same, devices mounted on said nut adapted to contact with said arms respectively at the ends of the travel of said nut, and an arm to control the rudder slidably connected with said nut.

In testimony whereof I affix my signature in presence of two witnesses.

JOHN S. CLARKE.

Witnesses:

E. M. FISHER,
F. C. MUSSUN.