



US00D487398S

(12) **United States Design Patent** (10) **Patent No.:** **US D487,398 S**
Bremner et al. (45) **Date of Patent:** **** *Mar. 9, 2004**

(54) **NOZZLE FOR DISPENSING VISCOUS MATERIAL**

D430,008 S 8/2000 Gobe

FOREIGN PATENT DOCUMENTS

(75) Inventors: **Brian M. Bremner**, Jersey City, NJ (US); **Helen H. Karask**, Jersey City, NJ (US); **Christine R. Tanner**, Jersey City, NJ (US)

DE A30038 12/1959
EP 0178377 5/1985

* cited by examiner

(73) Assignee: **SmithKline Beecham Corporation**, Philadelphia, PA (US)

Primary Examiner—Louis S. Zarfaz

Assistant Examiner—Gregory Andoll

(74) *Attorney, Agent, or Firm*—Nora Stein-Fernandez; Theodore R. Furman

(*) Notice: This patent is subject to a terminal disclaimer.

(57) **CLAIM**

(**) Term: **14 Years**

The ornamental design for a nozzle for dispensing viscous material, as shown and described.

(21) Appl. No.: **29/160,530**

DESCRIPTION

(22) Filed: **May 13, 2002**

(51) **LOC (7) Cl.** **09-07**

(52) **U.S. Cl.** **D9/434; D9/442; D9/447**

(58) **Field of Search** **D9/434, 435, 447, D9/442, 302; 222/519-521, 153**

FIG. 1 is a perspective view of one embodiment of the nozzle for dispensing viscous material;

FIG. 2 is a top plan view of one embodiment of the nozzle;

FIG. 3 is a bottom plan view of one embodiment of the nozzle;

FIG. 4 is a front plan view of one embodiment of the nozzle;

FIG. 5 is a back plan view of one embodiment of the nozzle;

FIG. 6 is a left-side view of one embodiment of the nozzle;

FIG. 7 is a right-side view of one embodiment of the nozzle;

FIG. 8 is a perspective view of another embodiment of the nozzle;

FIG. 9 is a top plan view of another embodiment of the nozzle;

FIG. 10 is a bottom plan view of another embodiment of the nozzle;

FIG. 11 is a front plan view of another embodiment of the nozzle;

FIG. 12 is a back plan view of another embodiment of the nozzle;

FIG. 13 is a left-side view of another embodiment of the nozzle; and,

FIG. 14 is a right-side view of another embodiment of the nozzle.

The broken lines in the Figures are for illustrative purposes only and form no part of the claimed design.

(56) **References Cited**

U.S. PATENT DOCUMENTS

D136,098 S	*	8/1943	Hartman et al.	D9/447
D179,333 S	*	11/1956	Tupper	D9/447
D186,975 S		1/1960	Werner		
3,093,274 A	*	6/1963	Galbierz	222/519
3,595,441 A		7/1971	Grosjean		
D246,228 S		11/1977	Hoy		
D274,696 S	*	7/1984	Marsden	D9/447
4,598,839 A	*	7/1986	Dombroski et al.	222/153
D304,791 S		11/1989	DeVigili		
D343,358 S		1/1994	Lay et al.		
5,324,505 A		6/1994	Kornettka et al.		
D351,101 S		10/1994	Linnèr		
D373,722 S		9/1996	Kastberg		
D376,100 S		12/1996	Beaver		
D378,718 S		4/1997	Daansen		
D399,423 S	*	10/1998	Palestrant	D9/447
5,823,387 A		10/1998	Manadanas et al.		
5,868,323 A		2/1999	Cantor		
D413,063 S		8/1999	Bell et al.		

1 Claim, 8 Drawing Sheets

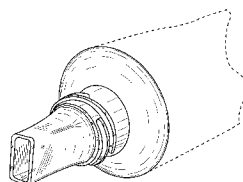
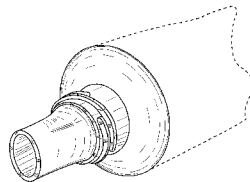

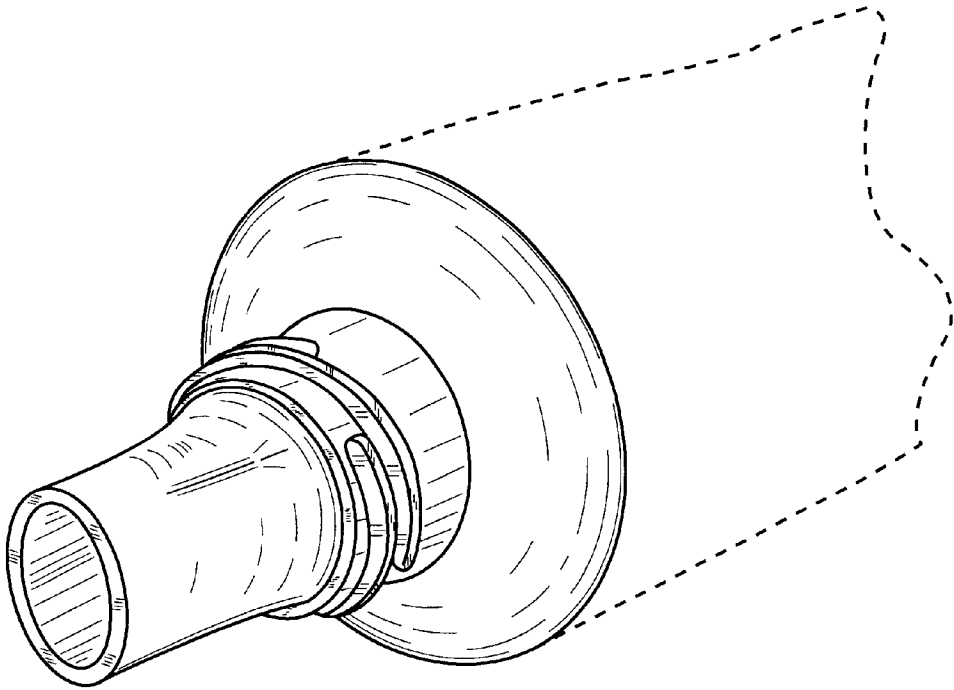

FIG. 1

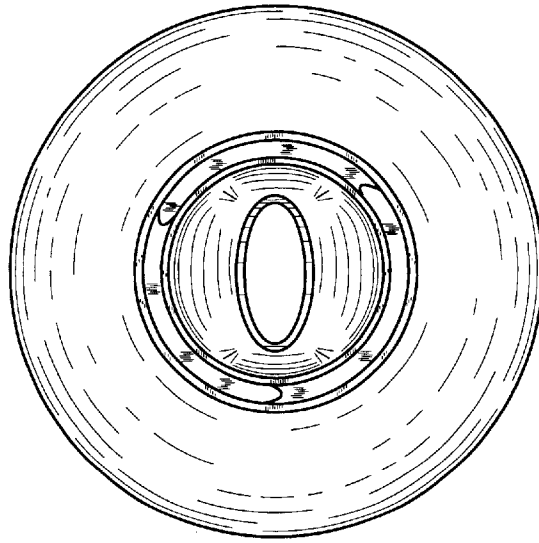

FIG. 2

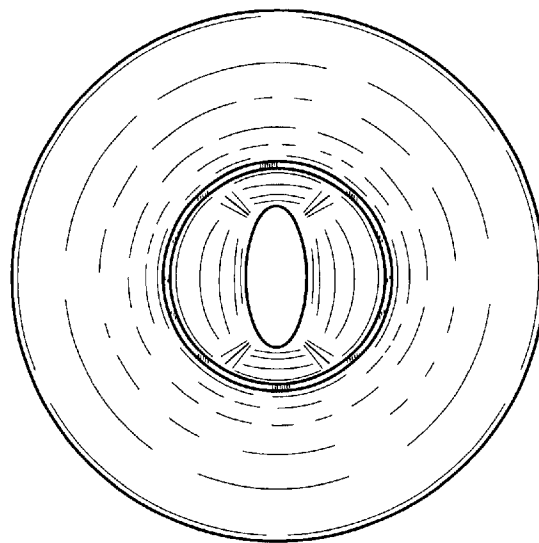

FIG. 3

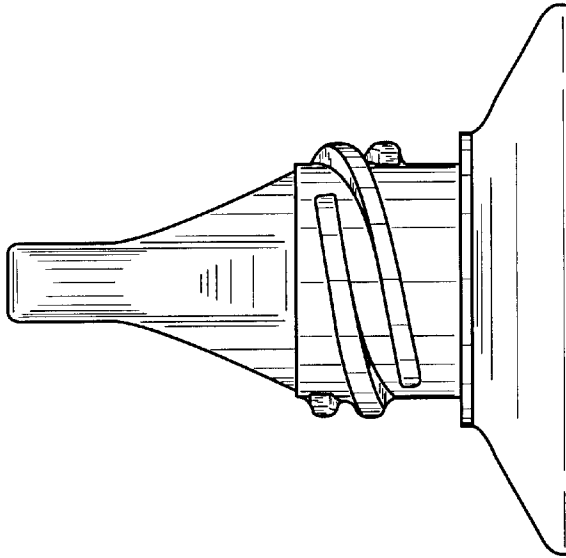

FIG. 4

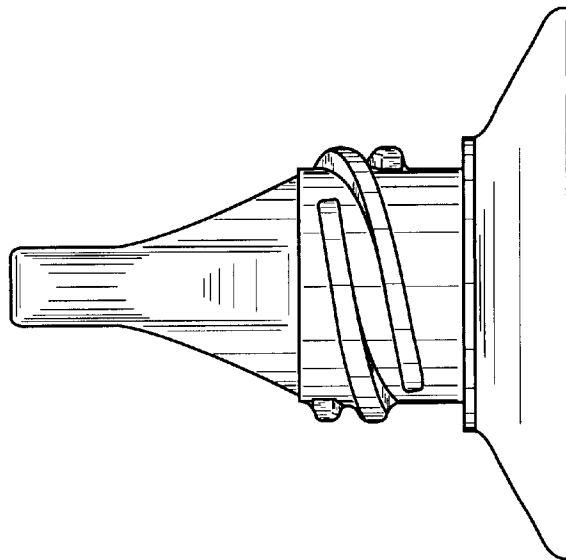

FIG. 5

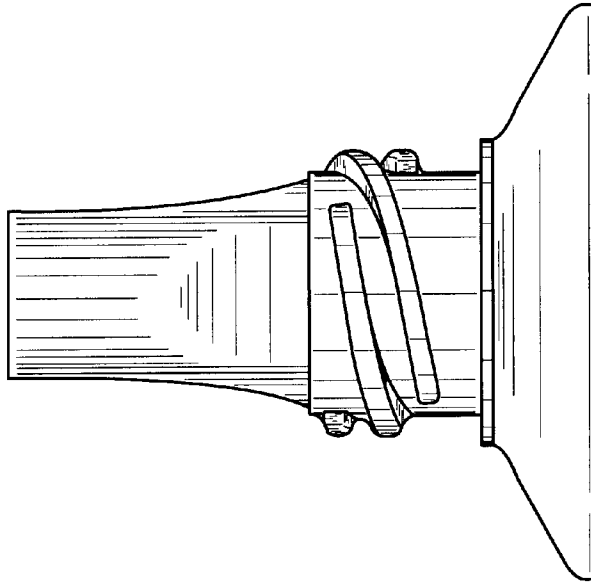

FIG. 6

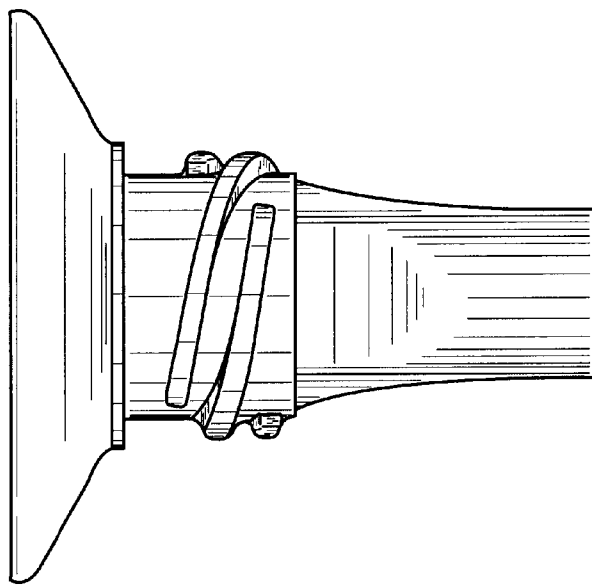

FIG. 7

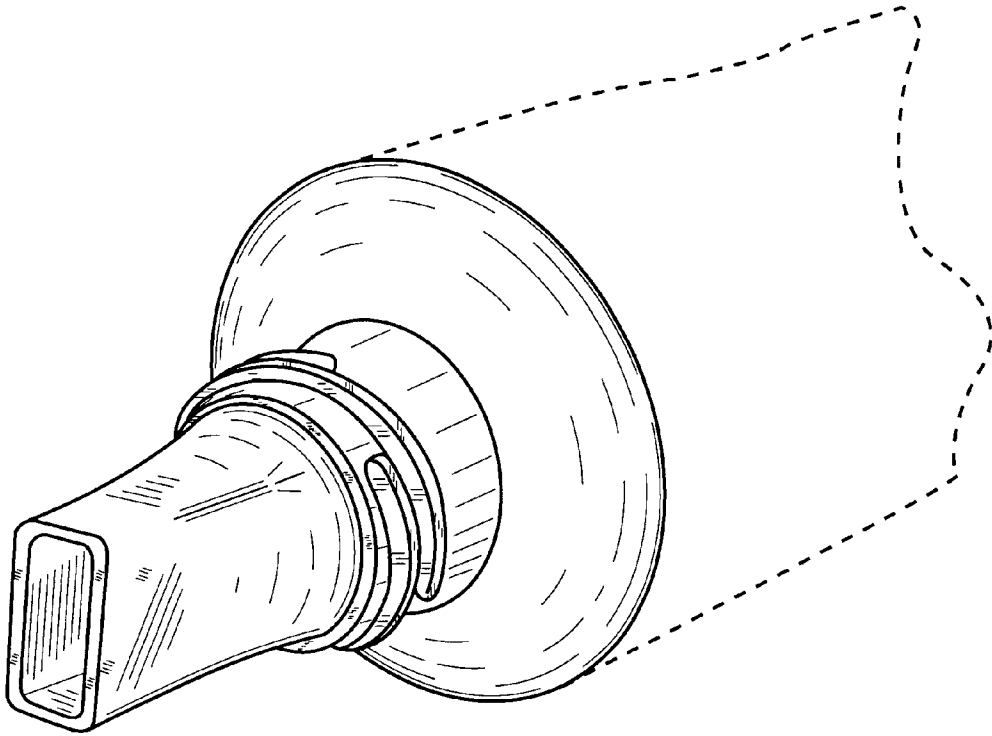

FIG. 8

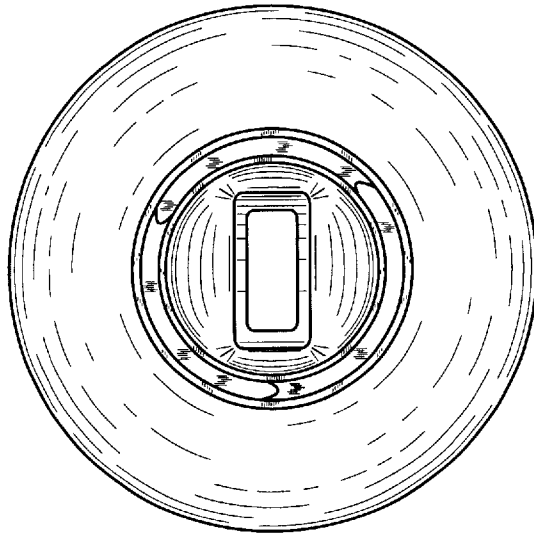

FIG. 9

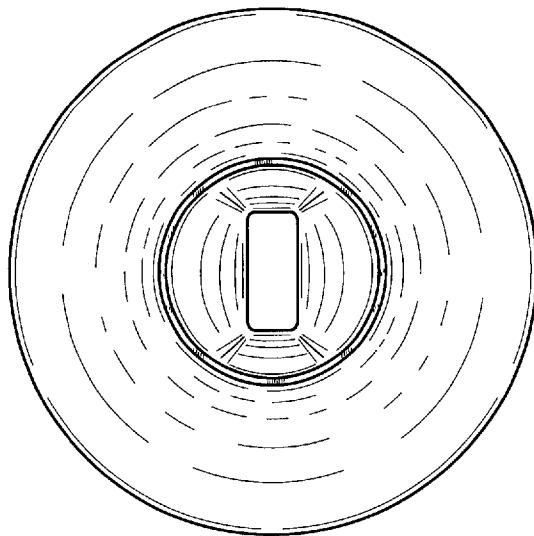

FIG. 10

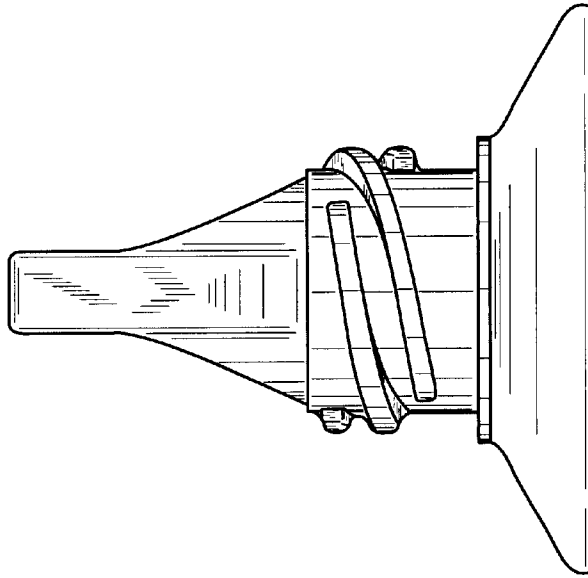

FIG. 11

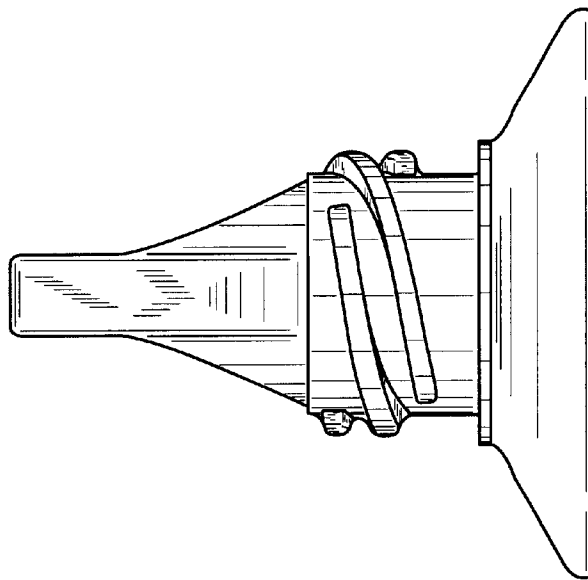

FIG. 12

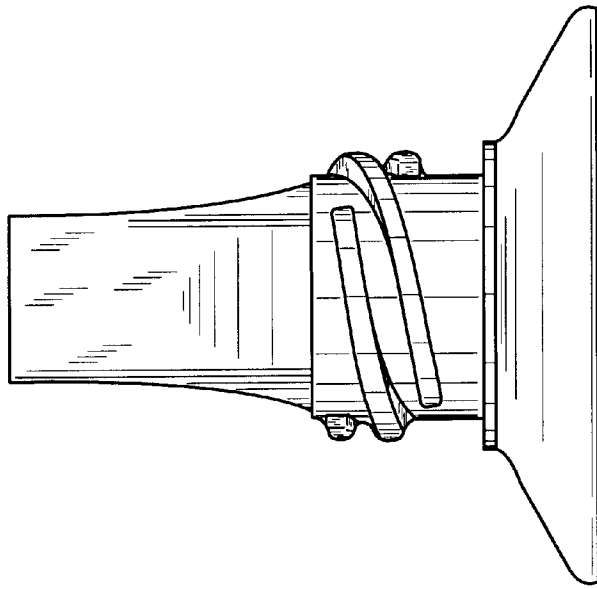

FIG. 13

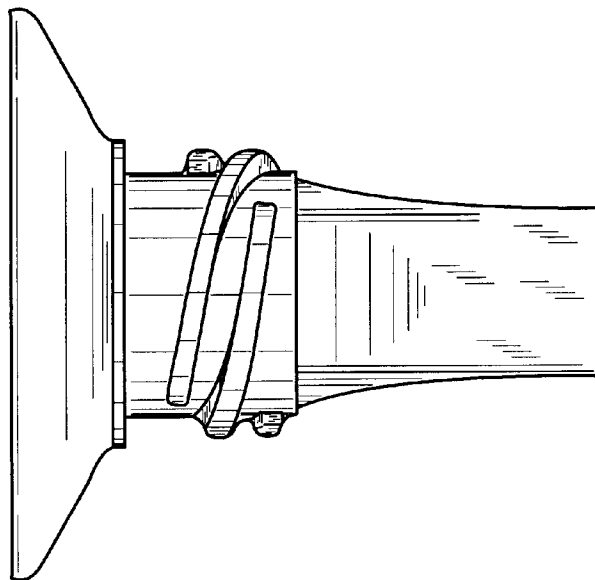

FIG. 14