



(12) EUROPEAN PATENT APPLICATION

(43) Date of publication:
22.07.1998 Bulletin 1998/30

(51) Int Cl. 6: F28F 9/26, F28D 1/02

(21) Application number: 98830019.0

(22) Date of filing: 20.01.1998

(84) Designated Contracting States:
AT BE CH DE DK ES FI FR GB GR IE IT LI LU MC
NL PT SE
Designated Extension States:
AL LT LV MK RO SI

(72) Inventor: Lollo, Valter
I-40033 Casalecchio di Reno (Bologna) (IT)

(74) Representative: Dall'Olio, Giancarlo
c/o INVENTION s.a.s.,
Via delle Armi, 1
40137 Bologna (IT)

(30) Priority: 20.01.1997 IT BO970023

(71) Applicant: Lollo, Valter
I-40033 Casalecchio di Reno (Bologna) (IT)

(54) Method for producing radiant groups for thermal radiators

(57) A method for producing radiant groups (1) for thermal radiators includes first, die-casting of a pair of bodies (20) which form a pair of end heads (2) of a radiant group (1). Each body (20) has a cavity (21) which sets in communication a plurality of parallel channels (22) extending from the body (20). The cavity (21) communicates also with a pair of pipe stubs (23), opposite to each other and with the axis perpendicular to the lay-

ing plane of the channels (22) axes. Then, the pipe stubs (23) are threaded, so that respective couplings (4) connecting with the adjacent radiant groups (1), can be screwed thereto. Afterwards, the cavity (21) of said body (20) is closed on the side opposite to the channels (22). Finally, the tapered mouths (30) of respective tubular radiant elements (3) are firmly joined to said channels (22) of the heads (2), arranged coaxial with the channels (22).

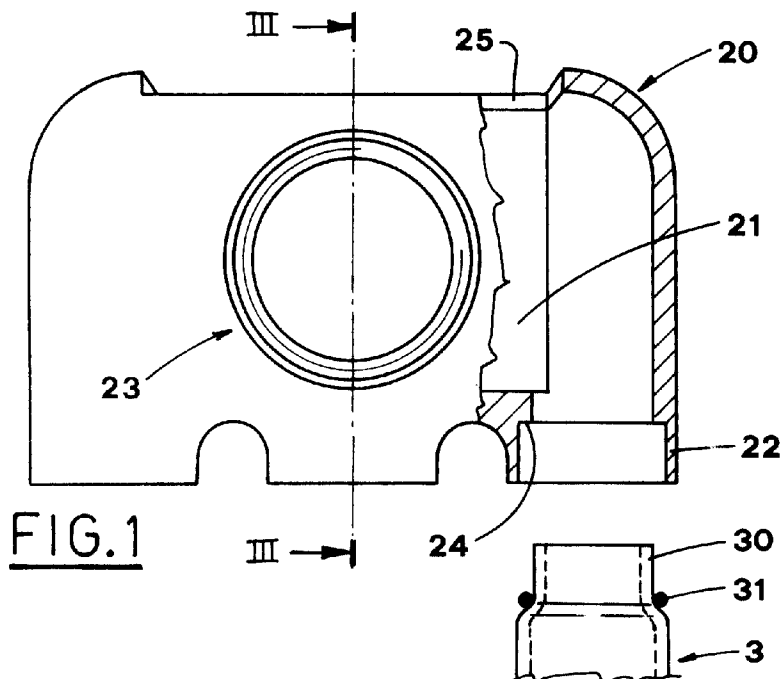

Description

The present invention relates to production of thermal radiators.

Thermal equipment industry, in particular for domestic heating, uses radiators formed by tubular radiant elements arranged vertically and equipped at their ends with relative heads that define suitable reciprocal connection means; the heads are connected one to another by e.g. threaded couplings, provided with suitable sealing means.

The above mentioned radiant groups are entirely obtained by die-casting or otherwise made of a pair of heads obtained by die-casting, to which a tubular element is connected; in some cases the tubular element is suitably finned so as to improve heat diffusion.

The radiant groups obtained in this way are usually expensive.

Moreover, known radiant groups are often little efficient, as far as heat exchange is concerned, they are also relatively heavy and not always connections are water-tight.

The object of the present invention is to provide a method which allows to obtain cheap radiant groups for thermal radiators.

Another object of the present invention is to provide a method for producing safe to use and highly efficient radiant groups for thermal radiators in a simple way.

The above mentioned objects are obtained in accordance with the content of the claims.

The characteristics of the invention will be better understood from the following description, with particular reference to the attached drawings, in which:

Figure 1 shows a side, partially sectional view of the body of one head that is used for production of radiant groups according to the subject method;

Figure 2 is a corresponding plan, partially sectional view;

Figure 3 is a corresponding cross section taken along the plane III-III of the Figure 1;

Figure 4 shows the same view as the Figure 3, of a subsequent production step of the above mentioned head;

Figures 5, 6, 7 and 8 show lateral schematic views of subsequent steps of assembly of the radiant groups, according to the subject method;

Figure 9 shows a corresponding front view of radiant group obtained in this way.

With reference to the above described figures, the subject method includes first, die-casting of the bodies 20 of a pair of end heads 2 of a radiant group 1. These

heads are preferably made of aluminium.

Each body 20 has a flattened form, with outer corners suitably rounded, and has a cavity 21 extending on a median plane from its top narrow surface. An opening 25 extends along the top surface of the body 20, so that the cavity is open to the outside. The edges of the opening 25 are bevelled.

In the body 20 there are also made cylindrical channels 22, e.g. 3 like in the example illustrated, which are set in communication with each other because of the cavity 21.

The channels 22 have circular section and limited axial extension. Moreover, on their inner surface, the channels 22 feature respective shoulders 24.

The cavity 21 communicates also with a pair of pipe stubs 23, extending from opposite sides of the body 20. The axis of each pipe stub is perpendicular to the median plane of the body.

The inner surface of the pipe stubs 23 is threaded, so as to form threaded sections 26, so that respective couplings 4 can be screwed thereto for connecting two or more adjacent radiant groups 1.

At the mouth of the threaded pipe stubs 23, there is made a ring-like seat 27 that houses a suitable seal 5 for the coupling 4 (see Figure 8).

Afterwards, the cavity 21 of the body 20 is closed on the side opposite to the channels 22 by a shaped plate 28, whose form is complementary to the opening 25; the closing plate 28 is firmly joined to the body 20 by a peripheral welding 29 (Fig. 4).

In practice, the closing plate 28 has preferably a rounded profile, so as to reconstruct the continuity of the outer surface of said head 2.

The so made heads 2 are firmly joined by the channels 22 to the opposite ends of a corresponding plurality of tubular radiant elements 3, arranged coaxial to the same channels 22 (Fig. 5).

The tubular elements 3 are preferably obtained by extrusion.

The tubular radiant elements 3 are aimed at being tightly introduced inside the channels 22 and, at their ends, these elements 3 are provided with respective tapered mouths 30, which engage with the narrow part of these channels 22 defined by the relative shoulders 24.

Respective gaskets 31 are mounted on the mouths 30 for keeping them tight against the above mentioned shoulders 24.

The tubular radiant elements 3 are firmly joined to the heads 2 by suitable glues, spread on the coupling housings defined by the channels 22 of the heads 2.

During the gluing step, the so obtained radiant group 1 is put in a vice equipped with a centring device 10 which precisely determines the distance between the centres of said threaded pipe stubs 23 of the heads 2 (Fig. 6).

The device 10 is substantially formed by a frame 11 equipped, on its ends, with a pair of pegs 12, protruding transversally and aimed at engaging said pipe stubs 23

of the heads 2 of the radiant group 1. The distance between the pegs 12 is adjustable.

Moreover, on its ends, the device 10 supports respective vices 13 which clamp the above mentioned heads 2 of the radiant group 1.

Therefore, the radiant group 1 is mounted on the device 10 by introducing the pegs 12, whose distance is precisely determined, into the pipe stubs 23 of the heads 2 and then by tightening these heads 2 between the vices 13 (Fig. 7).

The radiant group 1 is kept in the vice for a period of time sufficient for completing the step of gluing the tubular elements 3 to the heads 2.

Then, different radiant groups 1 are reciprocally fastened, so as to form the thermal radiator, by the couplings 4 which are screwed into the threaded pipe stubs 23 of the heads 2 (Fig. 8).

The couplings 4 feature, in known way, sections threaded in opposite directions, separated by the above mentioned seal 5.

The couplings 4 are preferably obtained from a metallic sheet, as disclosed in the Patent Application No. BO95A 000175, filed by the same Applicant.

Therefore, the subject method allows to obtain, in a simple way, radiant groups for heat radiators, formed by a pair of end die-cast heads and a plurality of tubular radiant elements.

In the illustrated case, the above mentioned radiant groups support three tubular elements between the heads.

Anyway, more tubular elements arranged in line can be provided, the number of which depends on requirements.

These tubular elements can be arranged not only in one line, but also in two or more lines, by providing the end heads with a corresponding number of channels connecting with these tubular elements.

Obviously, the length of the tubular elements can vary in relation to use specifications.

The production of radiant groups according to the described method is cheap, since they are produced by a limited number of simple operations and with a considerable material saving, in particular in correspondence to the end heads.

The last feature results in advantageous lightness of the radiant groups, which facilitates their transport and assembling.

An important feature of the radiant groups obtained according to the subject method is their best heating efficiency.

Moreover, these radiant groups are really tight, are easy to assemble and look pleasant, mainly due to the absence of sharp corners.

radiators characterised in that it includes:

die-casting of the bodies (20) of a pair of end heads (2) of a radiant group (1), with each one of said body (20) having a cavity (21) and a plurality of parallel channels (22) formed therein and set in communication with each other by said cavity, and with a pair of pipe stubs (23) extending from opposite sides of said body (20) and opening into said cavity;

threading of said pipe stubs (23), so that respective couplings (4) can be screwed thereto for connecting the adjacent radiant groups (1);

firm joining of the tapered mouths (30) of respective tubular radiant elements (3), to said channels (22) of the heads (2), so that said tubular elements are arranged coaxial with the channels (22).

2. Method, according to claim 1, characterised in that said cavity (21) of said body (20) has an opening (25) in the region of the top surface of said body, which opening is closed by a shaped plate (28), whose form is complementary to said opening (25) of said cavity (21), said closing plate (28) being firmly joined to said body (20) by a peripheral welding (29), so as to reconstruct the continuity of the outer surface of said head (2).
3. Method, according to claim 1, characterised in that said respective tubular radiant elements (3) are joined to said channels (22) of said heads (2) by being glued to the coupling housings defined by these channels (22), said housings having relative shoulders (24) that define corresponding narrowed portions of said channels (22), with which said tapered mouths (30) of said tubular elements (3) engage.
4. Method, according to claim 1, characterised in that, during the joining of said tubular radiant elements (3) to said channels (22), the radiant group (1) is put in a vice on a centring device (10) that maintains the distance between the centres of said threaded pipe stubs (23) of said end heads (2), said device (10) being equipped, on its ends, with a pair of pegs (12), protruding transversally and with adjustable distance, aimed at engaging said pipe stubs (23).

Claims

1. Method for producing radiant groups for thermal ra-

