

Oct. 6, 1959

H. COANDA
CARBURETOR

2,907,557

Filed Sept. 26, 1956

4 Sheets-Sheet 1

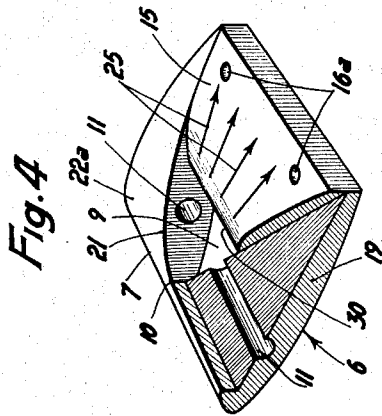
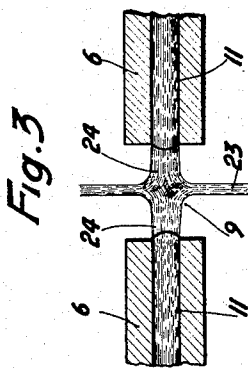
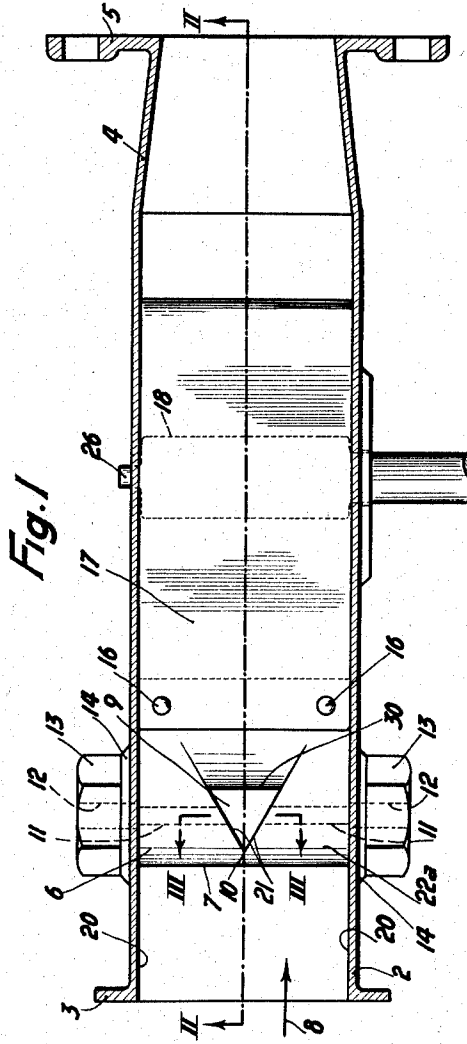
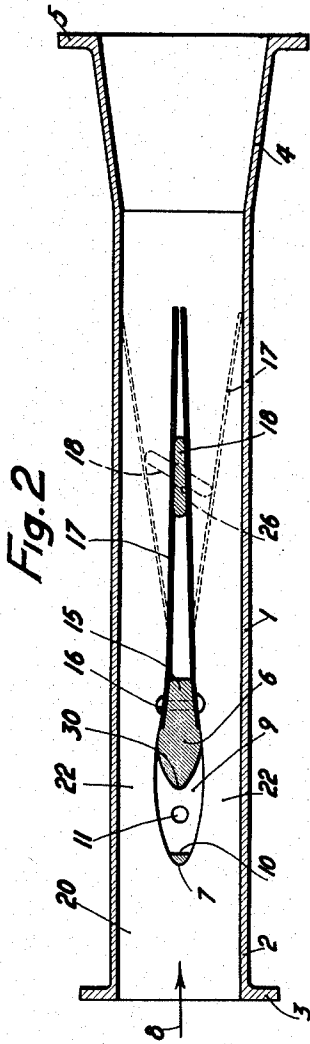

Oct. 6, 1959

H. COANDA
CARBURETOR

2,907,557

Filed Sept. 26, 1956

4 Sheets-Sheet 2

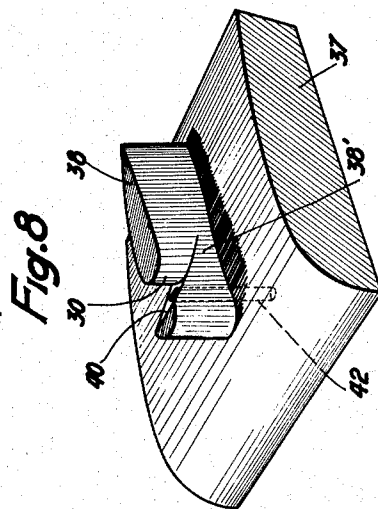
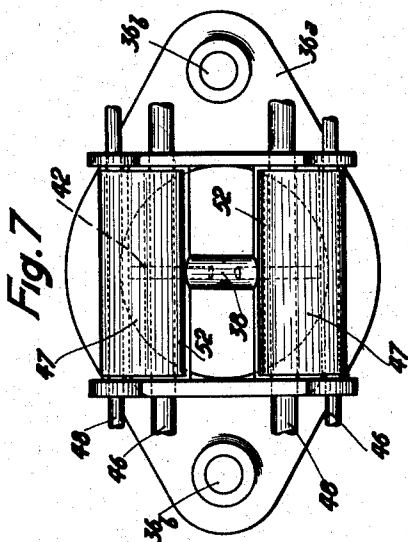
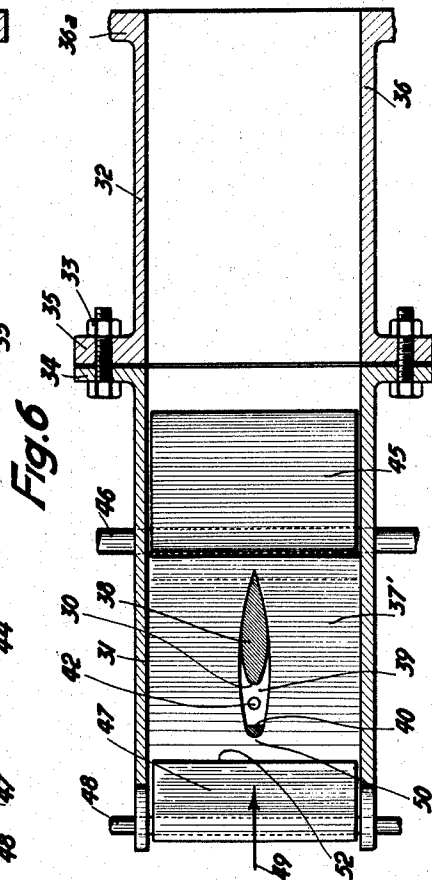
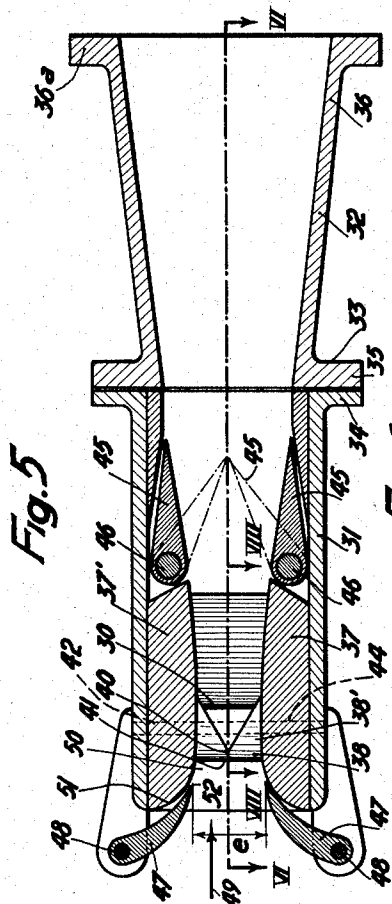

Oct. 6, 1959

H. COANDA
CARBURETOR

2,907,557

Filed Sept. 26, 1956

4 Sheets-Sheet 3

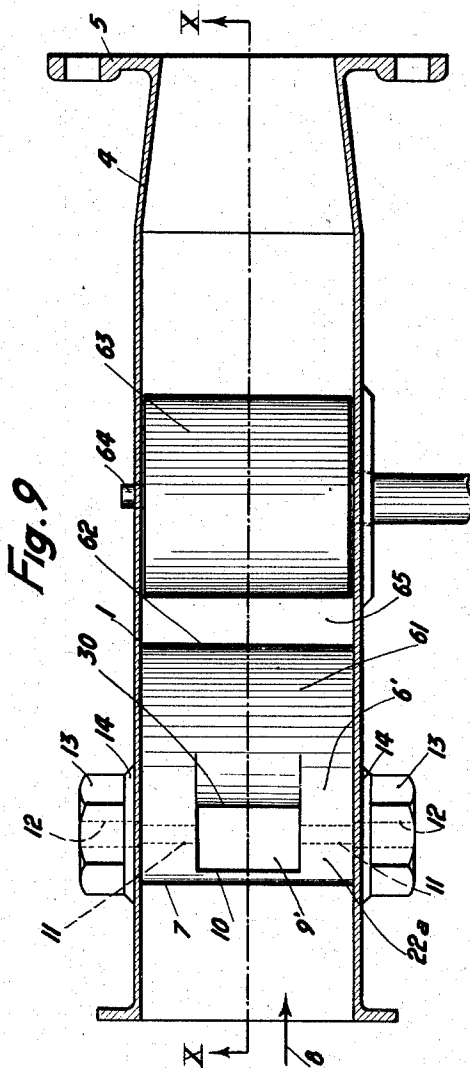
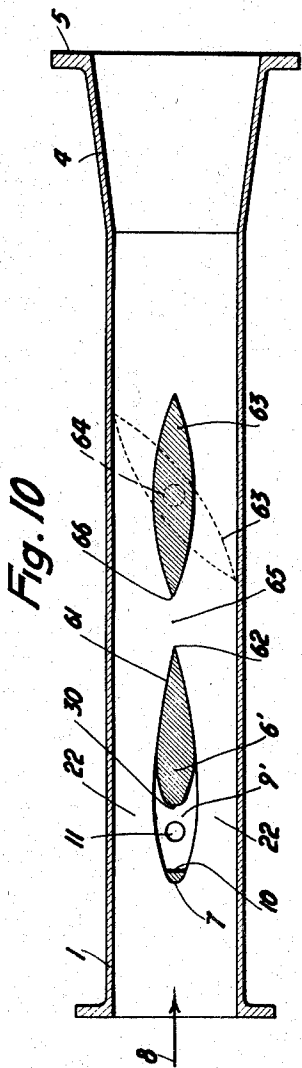

Oct. 6, 1959

H. COANDA
CARBURETOR

2,907,557

Filed Sept. 26, 1956

4 Sheets-Sheet 4

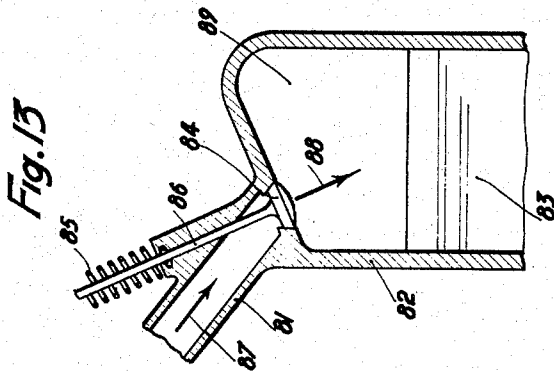
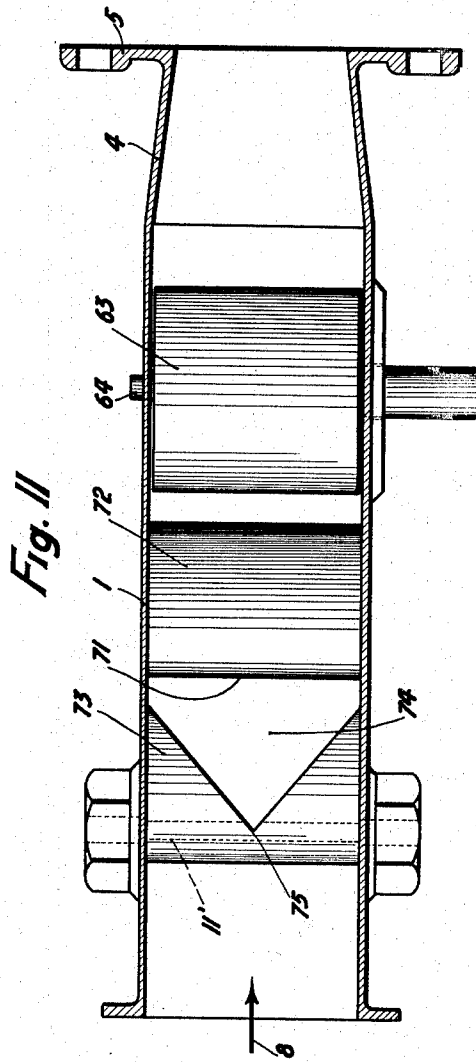
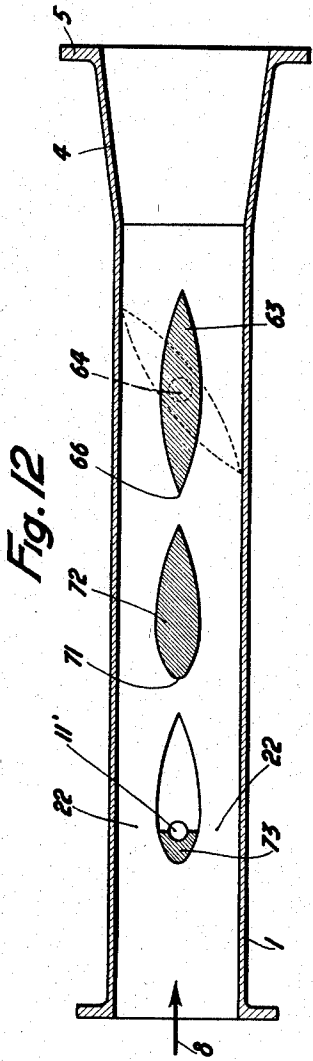

1

2,907,557

CARBURETOR

Henri Coanda, Paris, France, assignor to Societe Sebac Nouvelle S.A., Lausanne, Switzerland, a company of Switzerland

Application September 26, 1956, Serial No. 612,215

Claims priority, application France September 23, 1952

16 Claims. (Cl. 261—78)

This invention relates to a process for preparing carburized fuel-air mixtures effective to provide excellent combustion in the cylinders of internal-combustion engines and to a carburetor of novel construction. More particularly, the invention is concerned with a device which automatically insures the proper proportioning of a mixture of at least one carburant, e.g. gasoline, and one comburant, e.g. air, in the cylinders of internal-combustion engines.

It is known that it is desirable to feed the cylinders of an internal-combustion engine with a relatively cold carburized mixture which comprises very small liquid drops of fuel in suspension for the purpose of insuring the proper charging of the cylinders, and consequent efficaceous and efficient combustion. Fluids, and in particular hydrocarbons, which are generally utilized as carburants in internal-combustion engines of the explosion type, have a volume of the order of 1,000 to 2,000 times greater in the gaseous state than in the liquid state. It is consequently essential that, in a carburized mixture, the carburant should not be in the gaseous state but in the liquid state if one desires to assure a correct charging of the cylinders with the carburized mixture.

In accordance with the process of this invention, there is prepared a carburized mixture which holds in suspension small drops of liquid (as an atomized mist or aerosol) because the extreme velocity of the fluids handled effects atomization in the cold without gasification.

In accordance with one of the characteristics of the invention, there is obtained a carburized mixture containing ionized particles, the liquid particles exhibiting ionization of the same polarity, so that the particles repel each other and there is brought about an excellent distribution of the liquid particles in the cylinders of the engine, thus favoring combustion.

The carburetor of the invention is of a very economical construction and is free from the complex, expensive, and wear-prone mechanisms of carburetors heretofore known. Flow through the carburetor is easy to regulate at all times by means of simple controls and the carburetor provides a feed of fuel to the cylinders which approaches direct injection and thus assures an excellent filling of the cylinders with a mixture of a comburant and very fine liquid particles of the carburant, the mixture being at a relatively low temperature.

In order to realize the maximum benefits obtainable with the carburetor of the invention, it is advantageous to provide one carburetor for each cylinder, or, at the most, one carburetor for each two adjacent cylinders, which is economically possible owing to the greatly reduced cost of a carburetor according to the invention. One thus decreases the distance travelled by the carburized mixture and the number of changes in direction of flow of the mixture caused by the successive feed of several cylinders, as compared with the case when a single carburetor feeds several cylinders, such as in conventional motor vehicle engines. However, it is to be understood that, without departing from the scope of the invention,

2

one can use a single carburetor constructed in accordance with the invention to feed more than two cylinders, but such an arrangement is less advantageous.

There is disclosed in my co-pending application, Serial No. 377,898, filed September 1, 1953 now Patent No. 2,770,501, granted November 13, 1956, a liquid atomizing device characterized by the provision, in a conduit in which a fluid is caused to flow, of a blade or vane with a substantially symmetrical cross-section, which is disposed between walls only along that portion which corresponds to laminar flow of fluid along its extrados and its intrados, a substantially triangular cavity being formed in the blade with its apex directed towards the leading or upstream edge of the blade, grooves or channels being also formed in the blade for the purpose of bringing together in the above-mentioned cavity jets of the liquid or liquids to be atomized.

When one provides a blade or vane formed with a cavity or cutout and at least one channel to introduce in the cavity at least one jet of a carburant liquid, in a conduit or pipe, connected at one end to the ambient air (generally through an air filter) and at its other end to at least one cylinder of an internal combustion engine, so that the downstream or trailing edge of the blade is directed towards the cylinder, the intake of air resulting from the suction of the cylinder brings about in the conduit a flow which is at first laminar and, starting from the cavity, is turbulent, which causes very fine pulverization or atomization of the carburant liquid to form a carburized mixture having all of the desired characteristics.

Pulverization or atomization is begun in the depressurized area, or areas, created in the portion of reduced cross-section existing in the conduit at the point of maximum thickness of the blade, viz. the neck or necks, the cavity or cutout causing the creation of a turbulent flow at this point. It is in this depressurized area of turbulent flow that the arrival of the liquid to be atomized, viz. the carburant, a mixture of carburants, or a carburant and noncarburant liquid, takes place.

One of the characteristics of the invention is the fact that the arrival of at least one jet of carburant in a turbulent flow of liquid takes place in a depressurized zone. Another characteristic resides in the fact that there is provided downstream of this depressurized zone of turbulent flow another turbulent zone caused by an edge of the blade.

Consequently, the process of preparation of a carburized mixture, according to the invention, is characterized by the fact that there is created in the depressurized zone a turbulent flow of the comburant fluid, that there are brought together in this depressurized area of turbulent flow at least one jet of liquid carburant, so that there is a transformation of the carburant into small liquid drops which are drawn by the current of the comburant, and that there is created, downstream of this depressurized area of turbulent flow, a second turbulent zone in which there takes place an even finer atomization of the carburant in the comburant fluid.

In accordance with this invention, there is provided a carburetor body which includes a conduit having a front or upstream end adapted to be connected to an air filter of any convenient type and a back or downstream end adapted to be connected to the inlet opening of at least one cylinder of the internal combustion engine. The carburetor comprises at least one blade or vane positioned between the walls of the conduit, the blade having a cavity or cutout, and at least one groove adapted to be connected to at least one tank of carburant, the groove opening into the cavity or cutout which is formed in the blade. A vaning element or shutter may also be positioned in the carburetor conduit.

In the preferred embodiment of this invention, the cavity or aperture is formed in the portion of the blade

of maximum thickness and it is of substantially triangular outline, its apex being directed toward the leading or front edge of the blade, and two grooves or inlet channels are provided. The grooves are so arranged that a liquid disc is formed by the collision of the intruding jets of carburant discharging into the cavity from the two grooves or channels. The two jets of carburant may consist of the same carburant, e.g. gasoline, or of two carburants, e.g. gas-oil and alcohol, or of a carburant and a non-carburant liquid, such as water.

Indeed, the carburetor of this invention can be used for feeding of internal combustion engines, either of the 2-cycle or 4-cycle type, in automotive vehicles, motorcycles, motor scooters, motor bicycles, autorails, racing and sports cars, airplanes, electric power generating installations, and the like, not only with gasoline, such as used in ordinary carburetors, but also with other carburants, used singly or in combination, which are cheaper and which cannot be used in conventional carburetors, such as gas-oil, benzol, ethyl alcohol (even if impure and containing water) and the like. Similarly, as previously mentioned, mixtures of gasoline and water may also be handled.

The vaning element or shutter may, for example, take the form of a butterfly valve which is disposed in the conduit downstream of the apertured blade or vane, and which is movable to close off the conduit in varying degrees. The vaning element may also be in the form of shutters disposed at the downstream end of the apertured blade or vane and movable in such manner that they can close off the conduit in varying degrees. In another embodiment, the vaning element may be formed from two elastic blades or discs supported by the downstream end of the apertured blade and adapted to be separated from each other in varying amounts by a movable cam.

There are also advantageously provided corrector or compensator shutters positioned in the mouth of the conduit to regulate or adjust the admission of comburant gas and the flow velocity of the latter in the front portion of the conduit, thus regulating the richness of the carburized mixture. By partially closing the mouth of the conduit by means of these corrector or compensator shutters, the quantity of air admitted is decreased, and consequently the richness of the mixture is increased, which increases the air passage velocity in the front portion of the conduit by reason of the greater restriction of the cross-section of the space between the corrector or compensator shutters as compared with the inlet cross-section. This is useful, for example, in putting the engine into operation or in sudden acceleration. The operation of these shutters corresponds substantially to the operation of the starter in a conventional carburetor.

There may also be disposed in the conduit or tube or pipe, downstream of the apertured blade at least one other blade which provides a new and more pronounced atomization of the carburant liquid, this other blade, or one of these other blades, advantageously providing a vaning element.

It is necessary to provide at least one other blade downstream of the apertured blade when the cavity or cutout of the apertured blade, which is preferably triangular, extends to the rear extremity or trailing edge of the above-mentioned blade, in view of the fact that it is essential, in order to effect good atomization of carburant liquids in the carburant gas, that the aperture or cavity be followed by at least one edge. This edge may be supported by the apertured blade, when the cavity is formed in the front portion of the blade, and/or it may be supported by at least one blade placed downstream of the apertured blade.

The apertured blade and/or the other blades may advantageously be formed from a plastic material, e.g. a synthetic resin, or a metal, such as copper, which

facilitates the ionization of particles, particularly particles of liquid carburant.

Reference will now be made to illustrative embodiments of the invention which are not to be construed as in any way limiting the scope of the invention but which are to be considered merely as examples, these illustrative embodiments being shown in the accompanying drawings in which:

Fig. 1 is a plan view, partly in section of a carburetor embodying features of the present invention, the upper wall of the conduit being cut away;

Fig. 2 is a cross-sectional view of the construction of Fig. 1, as seen approximately along the line II—II of Fig. 1;

Fig. 3 is a further cross sectional view of a portion of Fig. 1, as seen approximately along the line III—III;

Fig. 4 is a perspective view, partly broken away to show details of construction, of the hollowed-out blade or wing shown in Figs. 1-3;

Fig. 5 is a longitudinal sectional view, partly in elevation, of a second embodiment of a carburetor of the invention;

Fig. 6 is a cross-sectional view of the construction of Fig. 5, as seen approximately along the line VI—VI of Fig. 5;

Fig. 7 is an end elevational view of the front of the carburetor shown in Figs. 5 and 6;

Fig. 8 is a perspective view of half of the atomizing device of the embodiment shown in Figs. 5-7, viz. the portion which is disposed below the section line VIII—VIII of Fig. 5;

Fig. 9 is a top plan view of a third embodiment of the carburetor of the invention, the upper wall of the conduit being removed;

Fig. 10 is a cross-sectional view of the embodiment of Fig. 9, taken approximately along the line X—X of Fig. 9;

Fig. 11 is a top plan view similar to Fig. 8 of a further modified form of carburetor according to the invention;

Fig. 12 is a cross-sectional view taken approximately along the line XII—XII of Fig. 11; and

Fig. 13 is a sectional view showing the manner of connecting the downstream end of the conduit of a carburetor constructed in accordance with the invention with the intake opening of a cylinder of an internal combustion engine.

Referring to the drawing, and more particularly to Figs. 1 to 4, the carburetor illustrated comprises a pipe or conduit 1 of rectangular cross-section which has a constant cross-section over the greater part of its length. The front or upstream end 2 of the conduit 1 is attached, by means of a flange 3, to an air filter (not shown), or to an auxiliary pipe disposed between it and the air filter, which is generally the case when only one air filter is used for several carburetors. The back or downstream portion 4 is attached by a flange 5 to the side of the inlet opening of the cylinder (not shown), when one carburetor per cylinder is used, or to the suction pipe communicating with the intake orifice of the cylinder or the intake orifices of several cylinders. Preferably the carburetor supplies not more than two cylinders.

In conduit 1 there is positioned a blade or wing 6 of substantially symmetrical structure having its upstream edge 7 directed toward the incoming air, the direction of flow of which is shown by the arrow 8.

In the thicker portion 22a of the blade 6 there is formed a substantially triangular cavity or recess 9, the apex 10 of which is directed toward the front or upstream end of the blade and the portion 22a is further provided with two channels or grooves 11 which are parallel to the upstream edge 7 and open into the cavity 9, one channel facing the other. In Fig. 4 a portion of blade 6 has been cut away in order to show the relative arrangement of the grooves or channels 11 and the cavity 9. Each groove or channel 11 connects with a nozzle 12 supported by a

fastening nut 13 attached by a weld 14 to the exterior of the conduit 1. The nozzles 12 are connected to one or two constant level fuel reservoirs or tanks (not shown), one tank being used in the case of a single carburant, and two tanks being used in the case of two carburants or a carburant and a noncarburant liquid.

The back or downstream portion of blade 6 has been truncated and on the remaining surface 15 there are attached, as by rivets 16, two elastic discs or plates 17 formed from steel and serving as flow-adjusting or regulating shutters. The rivets 16 pass through apertures 16a. Plates 17 are separated by variable amounts by means of a cam 18 to regulate or adjust flow through the conduit. The position of maximum flow is shown in Fig. 2 in full lines and the closed position is shown in broken lines.

From Fig. 1 it will be seen that blade 6 extends entirely between the walls of the conduit, its lateral sides 19 coming into contact with the lateral walls 20 of the conduit 1.

The carburetor shown in Figs. 1 to 4, operates as follows:

The suction of the cylinder or cylinders of the engine which is connected to the downstream end 4 of conduit 1 causes the inflow, through the air filter, of air into conduit 1 in the direction indicated by the arrow 8. Up to the point 10 of blade 6, the flow of air is laminar on the extrados and intrados of the blade 6. Due to the presence of the cavity or cutout 9, the laminar flow is progressively transformed into a turbulent flow, the line of separation between these two flows being to a great extent defined by the lateral elongated edges 21 of the triangular cavity 9, on the extrados as well as on the intrados. Moreover, at the height of the areas 22, to a great extent corresponding to the narrowed portions or necks of the flow of air into the conduit 1, a depressurized area is produced. This phenomenon is well-known in convergent-divergent nozzles in which the flow velocity attains its maximum at the neck in creating a depression.

It is in this substantially triangular depressurized area in which there exists a turbulent flow which produces the liquid disc 23 shown in Fig. 3 at the point of contact of the two jets 24, emerging channels 11, the triangular cavity 9 being formed in the area 22a of maximum thickness in the blade. The two jets 24 may be formed from the same carburant, two different carburants, or a carburant and noncarburant liquid such as water. The liquid disc 23 is transformed into fine, small drops of carburant under the combined effect of the depressurized zone and of the turbulent flow. Moreover, atomization is improved by the presence of the driving edge 30 which maintains and increases the turbulence. The small drops of liquid are thus distributed, in the direction of the arrows 25, throughout conduit 1 downstream of the blade 6 and onto plates 17. Ionization of the small drops, which occurs by reason of passage along the downstream portion of the blade 6, particularly when the blade 6 is formed from a plastic material or a metal such as copper which insures good ionization, tends to repel these small liquid drops from each other (the arrows 25 diverge) and consequently assure a good distribution of the drops in the downstream portion of the conduit 1 and in the cylinder or cylinders.

As mentioned, the elastic plates 17 and the regulating cam 18 are shown in a full line in the position in which they permit maximum flow of the carburized mixture. In the case of an automotive vehicle, this position of the elements 17 and 18 is produced when the driver presses the accelerator pedal "to the floor." By causing the cam 18 to rotate about its axle 26 under the action of the accelerator pedal, the flow of the carburized mixture can be decreased to a minimum value, corresponding to the fully released position of the accelerator pedal, in the case of an automotive vehicle. This minimum value will be zero when a special carburetion device is employed for reduc-

ing speed, such a device being placed downstream of the plates 17.

Referring now to Figs. 5 to 8 which show a second embodiment of a carburetor embodying features of the present invention, there is shown a conduit 31 of constant rectangular cross-section which is elongated by a diverging pipe 32 which is secured by means of bolts 33 which pass through suitable apertures in the flanges 34 and 35 of the conduit 31 and the pipe 32, respectively. The downstream end 36 of the pipe 32 is secured by means of flanges 36a formed with openings 36b (Fig. 7) to the inlet pipe or to one of the inlet pipes of the engine, or directly to one of the intake openings of a cylinder of the engine.

In the conduit 31 there are disposed, in a manner to form a prismatic converging-diverging nozzle, two wing-like members 37 and 37'. Between these members is disposed a vane or blade 38 extending entirely between the wall surfaces defined by members 37 and 37', the lower and upper ends of the blade being in contact with the upper surface of section 37 and the lower surface of section 37', respectively.

In the thickest portion 38' of the blade 38 there is formed a substantially triangular cavity 39, the apex 40 of which is directed toward the leading or upstream edge 41 of the blade 38. Two channels or grooves 42 are formed in blade 38 and in members 37 and 37' and these channels are adapted to be connected to one or two constant-level tanks (not shown) supplying a carburant, carburants, or a carburant and a noncarburant liquid. Downstream of the atomizing structure, defined by sections 37 and 37' and the blade 38, there are provided two shutters 45 for regulating flow, each movable around its axle 46. In front of the atomizing structure there are disposed two corrector or compensator shutters 47 which are movable around axles 48.

The carburetor shown in Figures 5 to 8 operates as follows:

The suction of the engine draws in air (through the air filter) into conduit 31 in the direction indicated by the arrow 49. The velocity of the air in the conduit 31 is accelerated in the region of the neck 50 which exists between the sections 37 and 37'. The blade 38 decreases further the cross-sectional area of the passage and further increases the velocity of the air which attains its maximum value in the region of the cavity 39 which is formed, as mentioned above, in the region 38' of blade or wing 38 where its thickness is the greatest. A significant depression is thus produced when the air reaches the zone 38' of maximum thickness of the blade 38. In the region of the cavity 39 there thus exists a depressurized area of turbulent flow in which a liquid disc (corresponding to the liquid disc 23 of the first embodiment described) is formed by bringing together the two jets of liquid emerging from the channels 42, this liquid disc being transformed into fine small drops by reason of the turbulent flow of air. Downstream of the atomizing structure defined by sections 37 and 37' and the blade 38 there is obtained a highly carburized mixture in which the air holds in suspension very fine drops of the carburant.

The flow of the carburized mixture is adjustable by means of shutters 45 which have been shown in Fig. 5 in solid lines in the position which they occupy to insure maximum flow, and in broken lines in the position in which they provide minimum flow. As in the first embodiment, if the minimum flow is zero, a special device for the preparation of the carburized mixture, corresponding to the reduction in speed, is provided downstream of the shutters 45.

The richness of the carburized mixture is regulated by means of the corrector or compensator shutters 47, which permit the variable adjustment of the inflow of air through opening 51 of conduit 31. By decreasing the inflow of air, the richness of the carburized mixture is increased, and at the same time, the velocity of the flow of

air is increased by reason of the reduction in the cross-section of the passage when the distance e between the extremities 52 of the two corrector or compensator shutters 47 is decreased.

The third embodiment of the invention shown in Figs. 9 and 10 is a variant of the first embodiment which has been described above and is shown in Figs. 1 to 4. The only differences between these two embodiments lie in the form of the cavity or cutout provided in the blade and in the construction of the vaning device or shutter. Accordingly, all parts other than the blade and the shutter have been given the same reference numbers as the corresponding elements of Figs. 1 and 2.

The blade 6' of the embodiment of Figs. 9 and 10 is of the same type as the blade 6 of the first embodiment except for the following two differences, viz.: the triangular cavity 9 of the blade 6 is replaced by a rectangular cavity 9' formed in the blade 6' and the downstream portion 61 is provided with an edge 62 in this third embodiment but not in the first embodiment which is provided with the elastic plates 17.

The shuttering action of the plates 17 is effected in the embodiment of Figs. 9 and 10 by a keeled butterfly regulating valve 63 which may occupy, around its axle 64, all of the intermediate positions between the position shown in full line on Fig. 10, corresponding to the maximum flow of the carburized mixture, and the position shown in broken lines, corresponding to minimum flow of the carburized mixture.

As in the embodiment of Figs. 1 to 4, a liquid disc is produced by the collision of the two jets flowing through channels 11 from the constant level tank or tanks (not shown), in the depressurized areas 22 of turbulent flow existing in the vicinity of the rectangular cavity or cutout 9' which is formed in the thickest portion 22a of the blade 6'. The small liquid drops which are held in suspension in the area 65, which lies between the edge 62 and the blade 6' and the leading edge 66 of the keeled butterfly valve 63, are divided into even finer small drops by the turbulence produced as a result of the action of the edge 66, the butterfly valve 63 thus not only functioning to regulate the flow of carburized mixture but also serving to effect better atomization. Moreover, in some cases, it increases the ionization of the small drops of liquid which have already been ionized by the blade 6'.

In Figs. 11 and 12 is shown a fourth embodiment of the invention in which the leading or upstream edge following the cavity, e.g. the edge 30 shown in Figs. 1-4 which is supported by the apertured blade 6, is provided at 71 by a second blade 72 disposed in conduit 1 (having the same construction as the conduits of the above described embodiments) downstream of the cutout blade 73.

The vaning device is identical with the one shown in Figs. 10 and 11 and the reference numbers of Figs. 10 and 11 have been used to designate the keeled butterfly valve 63 movable around its axle 64 between the position shown in full lines, corresponding to the maximum flow of carburized mixture, and the position shown in broken lines, corresponding to minimum flow of carburized mixture.

The primary atomization is effected in this fourth embodiment by means of the cutout blade 73 in which the triangular recess 74 extends from the thickest part of the blade to the trailing or downstream end of the blade.

It is clear from Figs. 11 and 12 that the channels or grooves 11' open into the cavity 74 at its apex 75 and thus produce a type of half-disc of liquid by the inrushing contact of the two jets flowing through these grooves or channels. It is this half-disc of liquid which is atomized by the turbulent flow of the air which is sucked in, in the direction of the arrow 8, by the vacuum produced in the cylinder or cylinders of the engine, this action occurring in the depressurized areas 22 of minimum cross-section.

This primary atomization effected by blade 73, is insufficient to provide an optimum carburized mixture. Therefore, in this embodiment there is provided a secondary atomization which is effected by the flow of the carburized mixture along the blade 72 and the keeled butterfly valve 63 from their leading edges 71 and 66, respectively.

In Fig. 13 there is shown illustrated a typical connection between the suction pipe 81, or the downstream portion 4 of the conduit 1 of Figs. 1 to 4 and 9 to 12, or the pipe 32 of the embodiment shown in Figs. 5 to 8, and the portion of the cylinder 82 surrounding the combustion chamber 89 above the piston 83. The valve 84 is acted upon by the spring 85 which surrounds the stem 86 and closes the intake port in conventional manner.

It should be noted that it is advantageous to dispose the pipe 81 in such manner that the carburized mixture, drawn in the direction of the arrow 87, when the piston 83 opens the intake port, does not undergo any significant change in direction as the mixture flows into the chamber 89. It will be seen that the exhaust port and the conventional associated portions of the cylinder have not been shown in the drawing.

It will be understood that various changes may be made in the embodiments described and illustrated, and various improvements or additions, or the replacement of certain elements by other corresponding elements, may be effected without departing from the scope of the invention as defined in the appended claims.

For example, only one channel or more than two channels might be provided in the apertured blade to bring together the liquid or liquids in the cavity or aperture in the blade. The aperture or cavity may also be given a shape other than the triangular and rectangular shapes shown in the drawings. The device for the preparation of the carburized mixture for slow speed may also comprise an apertured blade in which at least one channel has been formed.

It will be further understood that, insofar as they are not mutually incompatible, the various features and details of construction of the several embodiments shown and described are interchangeable with one another. It is intended, therefore, that all matter contained in the foregoing description and in the drawings shall be interpreted as illustrative only and not as limitative of the invention.

This application is a continuation-in-part of my copending application, Serial No. 377,898, filed September 1, 1953 now Patent No. 2,770,501, granted November 13, 1956.

What I claim and desire to secure by Letters Patent is:

1. A process of preparing a carburized mixture, which comprises establishing a turbulent flow of a combustion-supporting fluid in a depressurized zone, introducing at least two coaxial jets of liquid fuel into said depressurized zone of turbulent flow in opposite directions and towards each other, said jets being thereby atomized by collision and entrained by the flow of said combustion-supporting fluid, and creating a second turbulent area downstream of the depressurized area of turbulent flow to effect an even finer atomization of the fuel in the combustion-supporting fluid.

2. A carburetor comprising, in combination, a conduit having a front end adapted to receive a current of air and to be connected to an air filter, and a back end adapted to communicate with the intake port of a cylinder of the engine to be fed, at least one vane of aerofoil cross-section disposed wholly within the walls of said conduit, at least one leading edge on the upstream side of said vanes, a substantially triangular central aperture formed transversely in one of said vanes, and at least two channels opening into said apertured portion in said blade, said channels being adapted to communicate with at least one source of a combustible fluid, and means for regulating the flow of fluid through said conduit.

3. A carburetor as defined in claim 2, wherein said triangular aperture is formed in the area of maximum thickness of the vane.

4. A carburetor as defined in claim 2, wherein the said substantially triangular aperture has its apex directed toward the leading edge of said vane.

5. A carburetor as defined in claim 2, wherein said last-named means comprises a movable butterfly valve disposed in said conduit downstream of said vane.

6. A carburetor as defined in claim 2, wherein said last-named means comprises movable shutters disposed in said conduit downstream of said vane.

7. A carburetor as defined in claim 2, wherein movable shutters are provided in the mouth of the conduit to regulate the flow velocity of intake air in the front portion of the conduit.

8. A carburetor as defined in claim 2, wherein at least one second vane is disposed in the conduit downstream of the apertured vane.

9. A carburetor as defined in claim 2, wherein the apertured vane is formed from plastic material, whereby to facilitate ionization of the atomized particles.

10. A carburetor as defined in claim 2, wherein the apertured vane is formed from copper.

11. A carburetor as defined in claim 2, wherein the apertured vane and the last-named means in the conduit are formed at least in part of a plastic material, whereby to facilitate the ionization of the atomized particles.

12. A carburetor as defined in claim 2, wherein the apertured vane and the last-named means are formed at least in part of copper.

13. A carburetor as defined in claim 2, wherein there are provided in the conduit two winged sections to define a neck of narrowed cross-section in said conduit, the apertured vane being disposed in this neck.

14. A carburetor comprising, in a conduit of rectangular cross-section having an upstream end adapted to receive a current of air and a downstream end adapted to communicate with the intake part of a cylinder of the engine to be fed, an aerofoil main blade of varying thickness and of substantially symmetrical profile disposed between two lateral walls of said conduit, said

main blade being completely traversed by an aperture of substantial dimensions relative to the dimensions of said blade, at least two channels opening into said aperture, said channels being adapted to communicate with at least one source of carburant, at least one other aerofoil blade including a leading and a trailing edge downstream of said aperture, and means for limiting the flow of fluid at least downstream of said aperture.

15. A carburetor as claimed in claim 14, wherein said aperture is substantially triangular with its apex directed towards said upstream end and is formed in the area of maximum thickness of said main blade.

16. A carburetor comprising in combination, a conduit having a front extremity adapted to receive a flow of air and to be connected to an air filter, and a rear extremity adapted to communicate with the intake port of a cylinder of an internal combustion engine, at least one vane of aerofoil cross-section disposed wholly within the walls of said conduit, at least one leading edge on the upstream side of said vanes, a substantially triangular aperture formed transversely in one of said vanes, at least two channels opening into said aperture, said channels being adapted to communicate with at least one source of a combustible fluid, means for regulating the flow of fluid through said conduit, said means comprising two elastic plates supported by the downstream portion of said apertured vane and a movable cam for selectively separating said plates.

References Cited in the file of this patent

UNITED STATES PATENTS

1,771,530	Edwards	July 29, 1930
2,088,464	Chandler et al.	July 27, 1937
2,094,959	Pulidori	Oct. 5, 1937
2,176,305	Killmeyer et al.	Oct. 17, 1939
2,585,205	Young	Feb. 12, 1952
2,613,999	Sher et al.	Oct. 14, 1952
2,770,501	Coanda	Nov. 13, 1956

FOREIGN PATENTS

504,871	Great Britain	May 2, 1939
---------	---------------	-------------