



INTERNATIONAL APPLICATION PUBLISHED UNDER THE PATENT COOPERATION TREATY (PCT)

| | | |
|---|-----------|--|
| (51) International Patent Classification ⁵ : B67B 7/04, 7/144 | A2 | (11) International Publication Number: WO 92/04273 (43) International Publication Date: 19 March 1992 (19.03.92) |
| (21) International Application Number: PCT/IT91/00074 (22) International Filing Date: 10 September 1991 (10.09.91) (30) Priority data: 83472 A/90 11 September 1990 (11.09.90) IT (71)(72) Applicant and Inventor: FABBRO, Alberto [IT/IT]; Via Udine, 38, I-33010 Cassacco (IT). (74) Agent: D'AGOSTINI, Giovanni; D'Agostini Organizzazione, Via G. Giusti, 17, I-33100 Udine (IT). (81) Designated States: AT (European patent), AU, BB, BE (European patent), BF (OAPI patent), BG, BJ (OAPI patent), BR, CA, CF (OAPI patent), CG (OAPI patent), CH (European patent), CI (OAPI patent), CM (OAPI patent), DE (European patent), DK (European patent), ES (European patent), FI, FR (European patent), GB (OAPI patent), GN (OAPI patent), GR (European patent), HU, IT (European patent), JP, KP, KR, LK, LU (European patent), MC, MG, ML (OAPI patent), MR (OAPI patent), MW, NL (European patent), NO, PL, RO, SD, SE (European patent), SN (OAPI patent), SU ⁺ , TD (OAPI patent), TG (OAPI patent), US. | | Published <i>Without international search report and to be republished upon receipt of that report.</i> |

(54) Title: CORKSCREW THAT EXTRACTS SIMULTANEOUSLY WITH THE CORK A PREVENTIVELY CUT PORTION OF THE CAPSULE ON THE NECK OF THE BOTTLE

(57) Abstract

The object of the invention is to provide a corkscrew (1) that extracts simultaneously with the cork (5) also a previously cut capsule portion (6) on the neck of a bottle (4), characterized in that it comprises coaxially the screw (13) for the extraction of the cork (5) a cutting means on the inside (24), to be clasped around to the neck of the bottle (4) for, before, after or during the screwing: to cut the coverage capsule (6) of the cork (5) from the neck of the bottle (4) and extract it directly and simultaneously with the same cork (5).

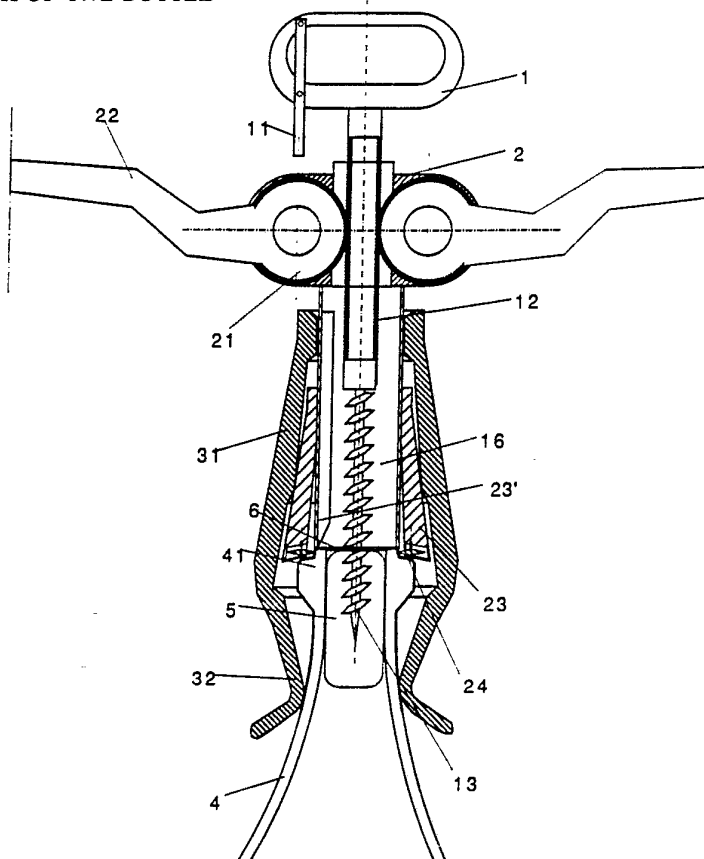

+ DESIGNATIONS OF "SU"

Any designation of "SU" has effect in the Russian Federation. It is not yet known whether any such designation has effect in other States of the former Soviet Union.

FOR THE PURPOSES OF INFORMATION ONLY

Codes used to identify States party to the PCT on the front pages of pamphlets publishing international applications under the PCT.

| | | | | | |
|----|--------------------------|----|---------------------------------------|-----------------|--------------------------|
| AT | Austria | ES | Spain | MG | Madagascar |
| AU | Australia | FI | Finland | ML | Mali |
| BB | Barbados | FR | France | MN | Mongolia |
| BE | Belgium | GA | Gabon | MR | Mauritania |
| BF | Burkina Faso | GB | United Kingdom | MW | Malawi |
| BG | Bulgaria | GN | Guinea | NL | Netherlands |
| BJ | Benin | GR | Greece | NO | Norway |
| BR | Brazil | HU | Hungary | PL | Poland |
| CA | Canada | IT | Italy | RO | Romania |
| CF | Central African Republic | JP | Japan | SD | Sudan |
| CG | Congo | KP | Democratic People's Republic of Korea | SE | Sweden |
| CH | Switzerland | | | SN | Senegal |
| CI | Côte d'Ivoire | KR | Republic of Korea | SU ⁺ | Soviet Union |
| CM | Cameroon | LI | Liechtenstein | TD | Chad |
| CS | Czechoslovakia | LK | Sri Lanka | TG | Togo |
| DE | Germany | LU | Luxembourg | US | United States of America |
| DK | Denmark | MC | Monaco | | |

1 In fact, these last devices have at one end the screw means to extract
2 the cork and at the other, the means to cut and extract the capsule.

3

4 Disclosure of Invention

5 The aim of this invention is to avoid said inconveniences.

6

7 This and other aims are reached with this invention as claimed, by
8 means of a corkscrew that extracts simultaneously along with the
9 cork also a preventively cut capsule portion on the neck of the
10 bottle, characterized in that it comprises coaxially with the
11 extraction screw of the cork, an element equipped with a means for
12 cutting towards the interior, that can be clamped around the neck of
13 the bottle and rotated before, after or during the screwing:

14 - to cut the coverage capsule of the cork from the neck of the bottle

15 and

16 - extract it directly with the same cork.

17

18 With this solution we obtain the advantage of cutting the
19 capsule and extracting the cork with only one operation, during the
20 same extraction phase of the cork with the further advantage that
21 the cut capsule portion rests directly encapsulated on the extracted
22 cork.

23

24 The invention is better understood with the enclosed
25 description and data supplied for example only, in which:

26 Figure 1 represents a schematic view of one of the many forms to
27 use corkscrews with a lever which cut the capsule with a clamping
28 means of conic coupling.

1 Figure 2 represents an alternative schematic view of a system of
2 clamping by means of a ring with a lever for tightening.

3 Figure 3 represents a view of a corkscrew simplified with a cutting
4 device with levers for clamping manually.

5

6 Referring to the Figures it is disclosed that:

7 - with 1 is indicated the extractor screw ensemble;

8 - with 2 the guide means and abutment to react to the extraction
9 force of the screw.

10 According to invention the cutting device is substantially associated
11 to this second element in order that, after screwing a part of the
12 screw in the cork and clamping, by means of the rotation of the
13 abutment guide and cutting means, we have the cutting of the
14 capsule by its rotation and then with the extraction of the cork the
15 cut capsule portion is extracted along with the respective cork.

16 On the basis of Figure 1 is illustrated a classic corkscrew with a lever
17 screw 1 supporting a toothed portion 12 and at one end, a screw for
18 screwing 13 inside cork 5 in the neck of bottle 4 covered by capsule
19 6.

20 The screw is moved axially by a pair of force levers 22 by means of
21 the tothing 21 on a guide compass and reaction 2 that extends
22 down with a tube to connect cork 16 and abutment and with free
23 elastic wings extending downwards towards the lower 23 supporting
24 idle rotating cutting wheels 24 and over this is brought an axially
25 sliding, conic coat 31 supporting two lower elastic guide arms 32, in
26 order to push, if lowered, the elastic wings towards the interior and
27 then the wheels 24 against the capsule 6 of the bottle in order to
28 rotate compass 2 and obtain the annular cutting of the capsule.

1 This conic coat (31) allows the elastic fins (23) to scroll inside of it
2 and to rotate freely even if clamped by the same coat against the
3 neck of the bottle, favouring also automatic screw centering.
4 Said rotation is made automatically by the eccentric peg 11 that
5 when the screw 13 is almost completely screwed inside the cork 5, it
6 engages with compass 2 making it rotate and therefore cut the
7 capsule.
8 After this it is sufficient to use the levers 22 lowering them in order
9 to extract the cork (5) and the cut capsule portion (6).
10 To facilitate the rotation we can provide also an annular thrust-
11 bearing abutment at the basis of the connecting tube of cork 16 in
12 order that this rests on the neck of the bottle (not illustrated).
13 The clamping of the little cutting wheels 24 can be made also by
14 means of the elastic ring 25 clamped by lever 25' or other equivalent
15 means as indicated in Figure 2.
16 In a simplified form the corkscrew includes, as indicated in Figure 3,
17 the extractable screw 1 in a compass-support 2 accomplished by
18 means of the pivoting 2c of two arms with foldable wings 23 having
19 an abutment 23' and under this the little cutting wheels 24 (Fig.3).
20 In this way we simply fold the wings 23 on the neck of the bottle and
21 we clasp manually to press the wheels on the external part of the
22 capsule, and with a rotating action they cut the capsule, after that
23 the cork is extracted with screw 1 by the simple action of screwing .
24 The advantage of having the openable arms (23) is that they
25 facilitate the extraction of the cork and capsule portion by the
26 screwing of the corkscrew.
27 With occurred extraction the two arms of the compass (23) are
28 opened for the extraction of the cork with the capsule portion.

- 1 Obviously said cutting means (24) can be also not rotatable cutters or
- 2 also knurled steel wire annularly clamped around to the neck of the
- 3 bottle.
- 4 We have illustrated two manual solutions but is evident that the
- 5 system can be adopted also in motored solutions.

1 Claims

- 2 1. A corkscrew (1) to extract simultaneously with the cork (5) also a
3 previously cut capsule portion (6) on the neck of a bottle (4),
4 characterized in that it comprises coaxially the screw (13) for the
5 extraction of the cork (5) a cutting means on the inside (24), to be
6 clasped around to the neck of the bottle (4) for, before, after or
7 during the screwing:
8 - to cut the coverage capsule (6) of the cork (5) from the neck of the
9 bottle (4) and
10 - extract it directly and simultaneously with the same cork (5).
11
- 12 2. A corkscrew according to claim 1, **characterized** in that the said
13 cutting means (24) are mounted on elastic means (23).
14
- 15 3. Corkscrew according to claim 1, **characterized** in that said
16 cutting means (24) are rotatable and serve for the cutting of the
17 capsule by means of rotating around the neck of the bottle.
18
- 19 4. A corkscrew according to claim 1, **characterized** in that said
20 cutting means (24) of the covering capsule (6) are inserted in the
21 respective holding compass means (23) on the neck of the bottle (4).
22
- 23 5. A corkscrew according to claim 1, **characterized** in that said
24 cutting means are free rotating cutting wheels.
25
- 26 6. Corkscrew according to claim 1, **characterized** in that the
27 support means (23) of said cutting means (24) involve abutment
28 means to open the neck (23') of the bottle (4).

1

2 7. A corkscrew according to claim 1, characterized in that the
3 support means (23) of said cutting means (24) involves abutment
4 means for the wider part of the neck of the bottle (23").

5

6 8 A corkscrew according to claim 1, characterized in that the
7 support means (23) of said cutting means (24) are wings extending
8 downwards and resiliently clamped (32) by means of a conic
9 compass (31).

10

11 9. A corkscrew according to claim 1, characterized in that the
12 support means (23) of said cutting means (24) are downward
13 extensions and resiliently clamped by means of a conic compass (31)
14 said compass involving the respective elastic downward extensions
15 that clamp under the wider part of the neck of the bottle (4).

16

17 10. A corkscrew according to claim 1, characterized in that in
18 association with said cutting means on the respective abutment
19 means (23', 23") there is installed a thrust-bearing ring to facilitate
20 the idle rotation.

21

22 11. Corkscrew according to claim 1, characterized in that the
23 rotation lever of the screw (1) has engagement means (11) that
24 during the screwing we engage the compass (2) support cutting
25 means (24) making it rotate.

26

27 12. A corkscrew according to claim 1, characterized in that the
28 rotation lever of the corkscrew 1 has an an engagement means (11)

1 that during the screwing the device engage the compass (2) of
2 support cutting means (24) making it rotate, said engagement means
3 being an eccentric peg (11) that the screwing engages with the
4 head of said compass (2).

5

6 13. A corkscrew according to claim 1, **characterized** in that said
7 support means (23) of said cutting means (24) consists in foldable
8 wings (Fig.3).

9

10 14. Corkscrew according to claim 1, **characterized** in that said
11 cutting means (24) are mounted on an elastic ring (25).

12

13 15. A corkscrew according to claim 1, **characterized** in that said
14 cutting means (24) are mounted on an elastic ring (25) open and
15 clamp manually.

16

17 16. A corkscrew according to claim 1, **characterized** in that said
18 cutting means (24) are mounted on an elastic ring (25) clamped with
19 lever (25').

1/2

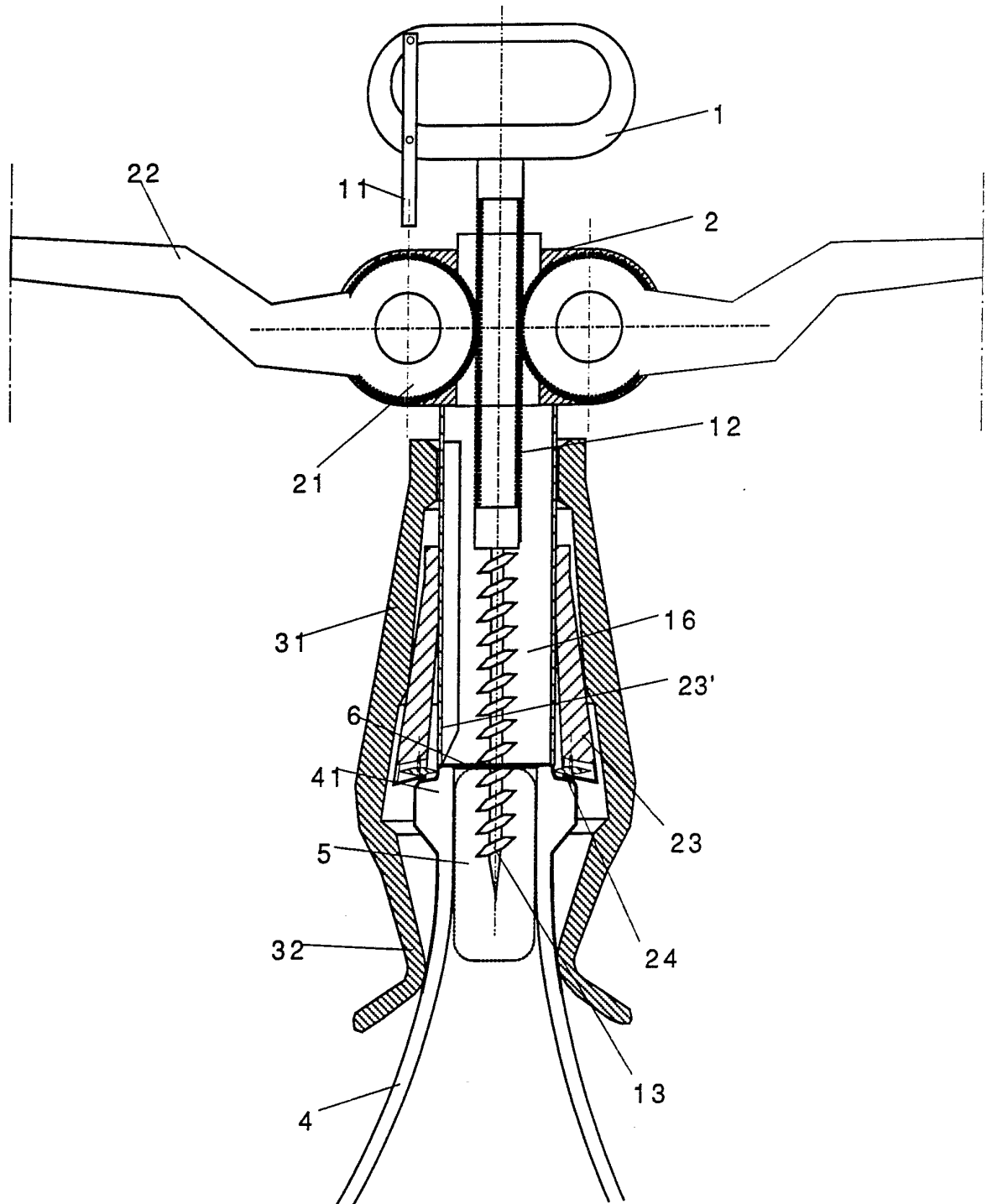

FIG. 1

2/2

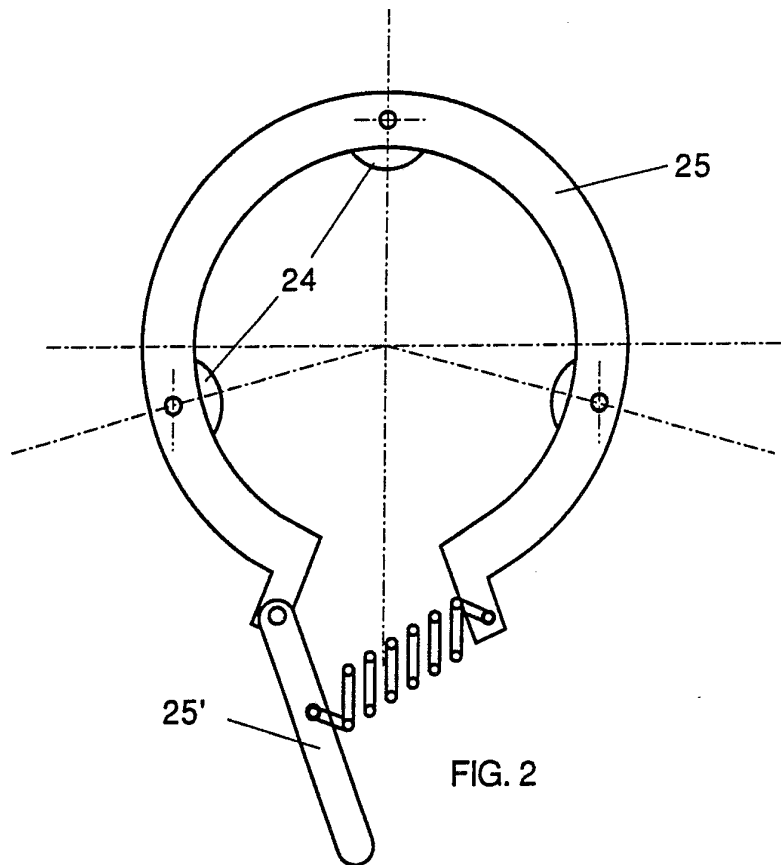

FIG. 2

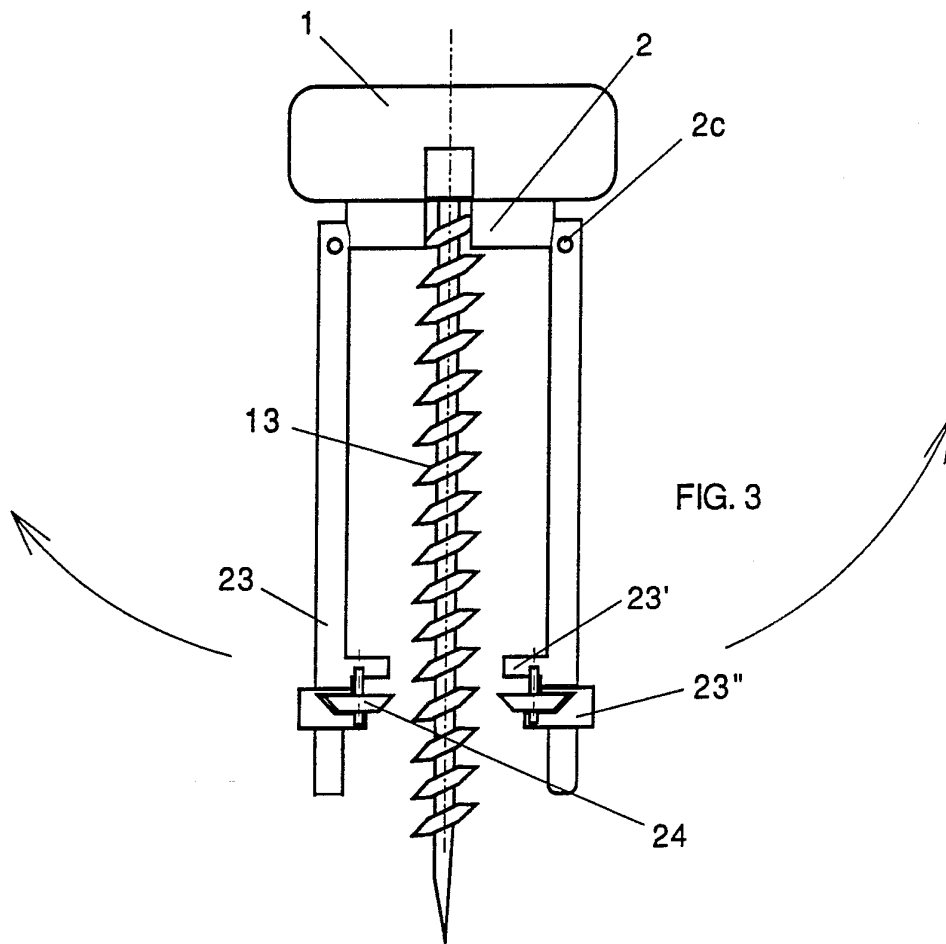

FIG. 3