

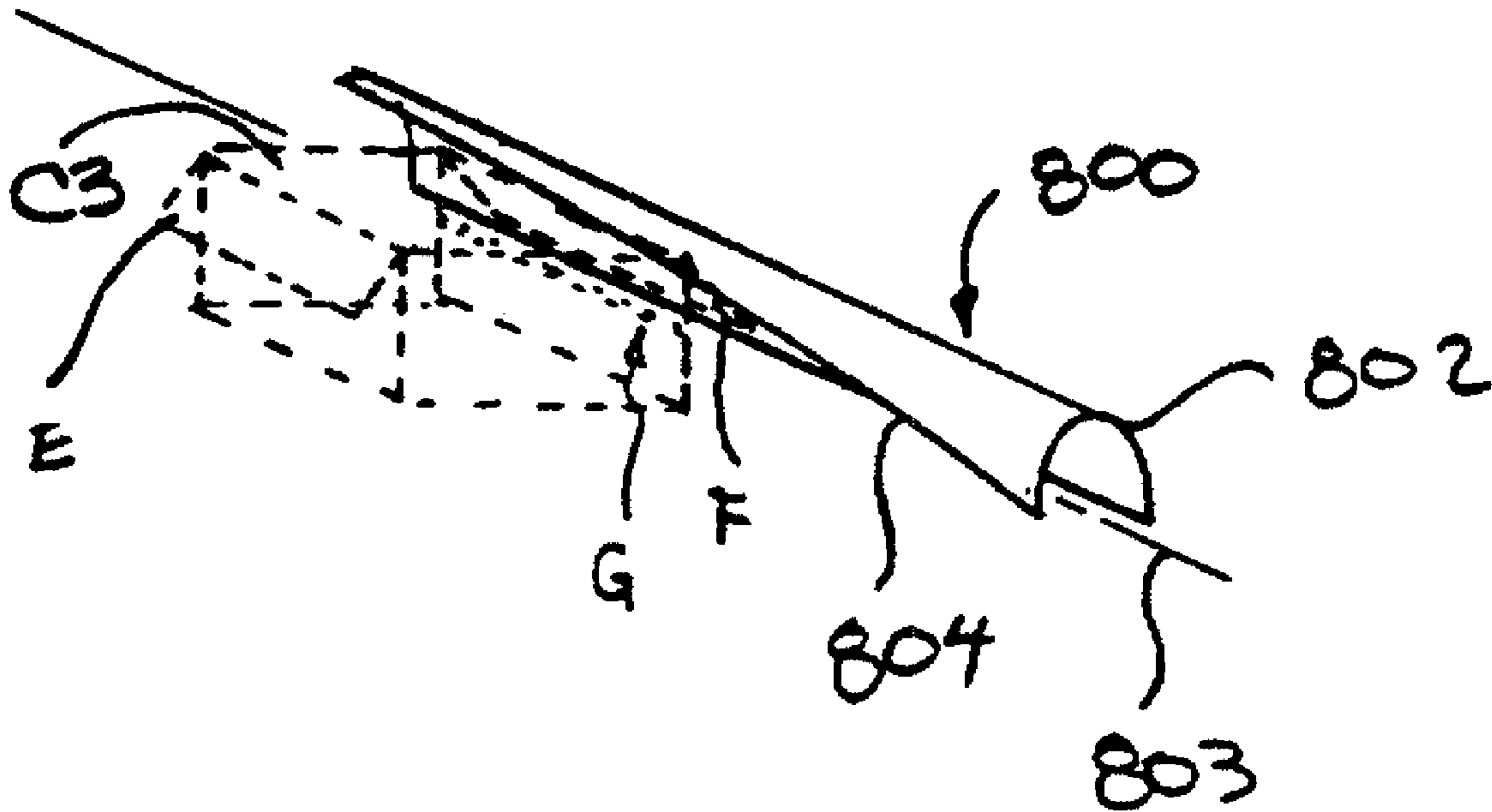

(86) Date de dépôt PCT/PCT Filing Date: 1999/10/21
 (87) Date publication PCT/PCT Publication Date: 2000/04/27
 (45) Date de délivrance/Issue Date: 2007/04/17
 (85) Entrée phase nationale/National Entry: 2001/04/20
 (86) N° demande PCT/PCT Application No.: US 1999/024617
 (87) N° publication PCT/PCT Publication No.: 2000/023321

(51) Cl.Int./Int.Cl. *B65B 7/20* (2006.01)
 (72) Inventeurs/Inventors:
 ROBINSON, GLENN, US;
 POTTEIGER, THOMAS M., US
 (73) Propriétaire/Owner:
 MEADWESTVACO PACKAGING SYSTEMS LLC, US
 (74) Agent: RIDOUT & MAYBEE LLP

(54) Titre : PLIEUSE A RABAT PIVOTANTE
 (54) Title: ROTATABLE FLAP FOLDER



(57) Abrégé/Abstract:

A cylindrical segment having a longitudinal axis has a helical edge which serves as a static flap folding edge for a carton in translatory motion with respect to the cylindrical segment. The cylindrical segment is reciprocally rotatable about an axis such that when the cylindrical segment rotates the helical edge progressively engages and folds a flap of a carton disposed at the helical edge.

**PCT**WORLD INTELLECTUAL PROPERTY ORGANIZATION
International Bureau

INTERNATIONAL APPLICATION PUBLISHED UNDER THE PATENT COOPERATION TREATY (PCT)

<p>(51) International Patent Classification ⁷ : B65B 7/20</p>	<p>A1</p>	<p>(11) International Publication Number: WO 00/23321</p> <p>(43) International Publication Date: 27 April 2000 (27.04.00)</p>
<p>(21) International Application Number: PCT/US99/24617</p> <p>(22) International Filing Date: 21 October 1999 (21.10.99)</p> <p>(30) Priority Data: 09/175,631 21 October 1998 (21.10.98) US</p> <p>(71) Applicant (for all designated States except US): THE MEAD CORPORATION [US/US]; Courthouse Plaza, Northeast, Dayton, OH 45463 (US).</p> <p>(72) Inventor; and (75) Inventor/Applicant (for US only): GARNIER, Jean-Michel [FR/FR]; Mead Packaging Europe, 3, ter rue Notre-Dame, F-36100 Issoudun (FR).</p> <p>(74) Agents: DREW, Michael, V. et al.; The Mead Corporation, 4850D North Church Lane, Smyrna, GA 45463 (US).</p>		<p>(81) Designated States: AU, BG, BR, BY, CA, CN, CR, CZ, EE, HR, HU, ID, IL, IN, JP, KE, KR, LT, LV, MX, NO, NZ, PL, RO, RU, SG, SI, SK, TR, UA, US, VN, YU, ZA, European patent (AT, BE, CH, CY, DE, DK, ES, FI, FR, GB, GR, IE, IT, LU, MC, NL, PT, SE).</p> <p>Published <i>With international search report. Before the expiration of the time limit for amending the claims and to be republished in the event of the receipt of amendments.</i></p>
<p>(54) Title: ROTATABLE FLAP FOLDER</p> <p>(57) Abstract</p> <p>A cylindrical segment having a longitudinal axis has a helical edge which serves as a static flap folding edge for a carton in translatory motion with respect to the cylindrical segment. The cylindrical segment is reciprocally rotatable about an axis such that when the cylindrical segment rotates the helical edge progressively engages and folds a flap of a carton disposed at the helical edge.</p> <div data-bbox="871 1676 1921 2240" style="text-align: right;"> </div>		

01-12-2000

1

US 009924617

ROTATABLE FLAP FOLDER

The invention relates to continuous-motion cartoning machines and, more particularly, relates to a mechanism capable of operating as both a static flap folder and a rotatably
5 reciprocating flap folder.

Continuous-motion cartoning machines are useful for packaging multiple articles such as beverage cans in cartons or other packaging components. An example of a continuous-motion cartoning machine is shown in U.S. patent No. 5,241,806 to Ziegler et al.

10

In a cartoning (or packaging) machine, a flap folder generally causes the side or end flap of a side- or end-loaded carton to be folded into flat-face relationship with an end or side panel or flap to which glue has been applied. The operation of a packaging (cartoning) machine is sometimes interrupted before a side or end flap is folded into face-to-face
15 contact with the side or end panel and/or flap to which glue has been applied. It can be appreciated that it would be useful to have a means for folding a carton flap into a sealable position with respect to an end or side panel and/or flap to which an adhesive has been applied when the operation of the machine has been interrupted. It can be further appreciated that it would be useful to have such a means that also folds carton flap to a
20 sealable position during regular continuous motion of the machine.

In US 328 758, there is shown a folder to fold a stationary carton. The folder has a helical element that rotates about an axis perpendicular to the folding action of the flap. The helical element comprises a pair of helically wound members which pass under the flaps
25 and fold the flaps inwardly.

The present invention and its preferred embodiments seek to overcome or at least mitigate the problems of the prior art.

30 One aspect of the invention provides a rotatable flap folder for folding a flap of a carton during continuous forward movement of the carton which folder comprises a helical blade having a longitudinally extending helical edge, and means to rotate the element characterised in that the helical blade is rotated about its longitudinal axis so

that the helical edge progressively engages and thereby folds the flap of a carton disposed adjacent the helical edge.

5 A second aspect of the invention provides a rotatable flap folder for folding a flap on a carton which folder comprises an element having a longitudinally extending helical edge, and means to rotate the blade about its longitudinal axis so that the helical edge progressively engages and thereby folds the flap of a carton disposed adjacent the helical edge characterised in that the element comprises a helical blade and in that an outer arcuate
10 face of the blade is urged into contact with the folded flap as the blade continues to rotate following folding of the flap. Preferably, a conveyor may be provided to cause relative longitudinal movement between the blade and the carton.

According to an optional feature of the second aspect of the invention the helical blade may be adapted to serve as a static flap folding edge for a carton in translatory motion with
15 respect to the blade.

According to another optional feature of the second aspect of the invention the helical blade may be rotatable about the longitudinal axis thereby to urge the flap into face contacting relationship with an end of the carton.
20

According to another optional feature of the second aspect of the invention the folder may be rotated to and fro in a reciprocal manner.

According to another optional feature of the second aspect of the invention the outer face
25 of the blade may be arcuate. Preferably, the outer face may be a substantially "U" shaped profile.

A third aspect of the invention provides a method for closing a carton flap comprising disposing a carton having an extended carton flap adjacent a rotatable flap folder wherein
30 the extended carton flap is disposed proximate the helical edge; then rotating the helical blade to fold the flap adjacent the helical edge, and continue folding the flap by abutment with the outer arcuate face of the blade thereby to urge the carton

01-12-2000

1b

US 009924617

flap into face-to-face relationship with an end of the carton. Preferably, the helical blade may be rotated about 90 degrees.

- 5 According to an optional feature of the third aspect of the invention, prior to engagement of the carton by the helical blade adhesive may be applied to an end wall of the carton to which the carton flap is to be pressed along a line which is coincident with a tangent line along which a cylindrical wall of the cylindrical segment structure contacts the carton.

Other advantages and objects of the present invention will be apparent from the following description, the accompanying drawings, and the appended claims.

Brief Description of the Drawings

5

Fig. 1 is an isometric illustration of a continuous-motion cartoning machine suitable for incorporation of a rotatable flap folder, in accordance with a preferred embodiment of the invention.

10

Fig. 2 is an isometric illustration of a rotatable flap folder, in accordance with a preferred embodiment of the invention, suitable for use in the machine environment of Fig. 1 illustrated with cartons engaged in translatory motion with respect to the flap folder.

15

Fig. 3 is an isometric illustration of the rotatable flap folder of Fig. 2 illustrated in conjunction with a carton having unfolded, unsealed flaps, wherein the carton is stationary.

20

Fig. 4 is the isometric illustration of the invention as shown in Fig. 3 but wherein the invention has been rotated to close the flaps that were extended in Fig. 3.

Fig. 5 is a downstream, end view of the invention in conjunction with a carton as is shown isometrically in Fig. 2 and Fig. 3.

25

DETAILED DESCRIPTION OF A PREFERRED EMBODIMENT

Throughout the drawings the same reference numerals are used to denote the same or like features of the invention.

30

Referring first to Fig. 1, therein is illustrated a continuous-motion cartoning machine M, suitable for incorporation of a rotatable flap folder in accordance with a preferred embodiment of the invention. In the machine, the carton hopper 10 receives

collapsed cartons C stacked in substantially upright condition as shown. Cartons C are withdrawn from the carton hopper 10 by the adjustable carton feeder 20 and then deposited in substantially erect condition at the beginning of the carton conveyor 30. As cartons are continuously engaged and translated through the machine M, articles, such as beverage cans, to be packaged in the cartons C are also translated through the machine in synchronous motion with the cartons. An article conveyor 40 and article lane arrangement 50 form an article transport that urges the articles into the cartons C. Article-engaging wheels 60 complete the process of placement of the articles into cartons C. Side-flap folding wheels 70 (partially obstructed in Fig. 1) engage and inwardly fold the side flaps of cartons having side flaps. Glue is applied to the cartons C at a gluing station 80. At a sealing station 90, end flaps of the cartons C are pressed and held into contact with glue that has been previously applied. Packaged, sealed cartons are ejected from the machine at the ejection station 100.

Referring now to Fig. 2, therein is illustrated a rotatable flap folder 800 disposed adjacent cartons C1, C2 traveling in translatory motion with respect to the flap folder 800. The cartons C1, C2 are traveling downstream in a direction indicated by the direction arrow 801. The carton C1 which is upstream, particularly with respect to the downstream carton C2, has end or side flaps E, F which lie extended away from the end/side walls of the carton C1. The terms "end" and "side" may be considered interchangeable in the description of the invention. the structure of the cartons C and the operation of the invention are the same irrespective of whether the flaps to be folded are referred to as "side" flaps or "end" flaps. Similarly, the term "flap" is interchangeable with the term "panel."

25

In a packaging/cartoning machine glue typically has been applied prior to the arrival of the cartons C at the flap folder 800. The flap folder 800 is a structure 802 which is generally a segment of a cylinder which is formed about an axis 803. The cylindrical segment 802 has a helical edge 804 which is its flap-contacting portion. It is to be noted that in a typical machine environment a flap folder is disposed at either side of the carton. Only one flap folder is shown in the accompanying figures for clarity and brevity. The structure and operation of an opposing flap folder would mirror that of the

30

flap folder 800 illustrated and discussed. Illustration and discussion of one flap folder 800 does not and is not intended to limit the scope or applicability of the invention.

As the upstream carton C1 with extended flaps E, F translates downstream the
5 extended flaps E, F and helical edge 804 of the flap folder 800 (as previously noted, a second flap folder is not depicted for brevity and clarity) engage one another in a progressive manner such that as the flap F travels the path of the helical edge it is ultimately pressed into face-to-face relationship with the end/side of the carton C. In this manner, the flap folder 800 serves as a stationary folding device.

10

Referring now to Fig. 3 and Fig. 4, the method of operation of the invention as a reciprocally-rotating flap folder is illustrated. A carton C3 is shown in phantom view so that the elements of the invention and the operation thereof can be clearly seen. The carton C3 is shown in a substantially stationary position although the invention is also
15 applicable to cartons which are in translatory motion as depicted in Fig. 2. The carton C3 is shown in a substantially stationary position because this is the situation of greatest applicability of the invention. In order to close the flap F of the stationary carton C3, the flap folder 800 is rotated about the axis 803 such that the helical edge 804 urges the flap F downward and inward into face-to-face relationship with the end/side of the carton
20 C3. The degree of rotation is that suitable to ensure closure of the flap. In the preferred embodiment illustrated in Fig. 4, a suitable rotation of 90 degrees has been used.

Referring now to Fig. 5, the cylindrical segment 802 can be made to rotate by any known drive train means; for example, a motor driving a drive shaft 806 which is coaxial with the axis 803 and at least one spoke element 808 interconnecting the drive
25 shaft and cylindrical segment 802.

Referring now simultaneously to Fig. 3 and Fig. 5, an additional feature of the invention is shown. The invention 800 is disposed at the path of a carton C such that a line along the end/side wall of the carton C is coincident with the tangent line of
30 cylindrical segment 802. In the method employed in accordance with the invention, a bead of glue (exaggerated for clarity in Fig 5) is applied along the tangent line G so that the wall of the cylindrical segment 802 presses the flap F against the glue line G during

translation of the carton C downstream and also upon rotation of the cylindrical segment 802.

The structure of the invention provides a flap folder 800 which is capable of
5 functioning as a stationary flap folder for cartons C in translatory motion and a reciprocally-rotatable flap folder for a stationary or moving carton C.

Modifications may be made in the foregoing without departing from the scope and spirit of the claimed invention.

10

What is claimed is:

CLAIMS:

1. A rotatable flap folder for folding a flap on a carton which folder comprises an element having a longitudinally extending helical edge, and means to rotate the element about its longitudinal axis so that the helical edge progressively engages and thereby folds the flap of a carton disposed adjacent the helical edge, characterized in that the element comprises a helical blade and in that an outer arcuate face of the blade is urged into contact with the folded flap as the blade continues to rotate following folding of the flap.
2. A rotatable flap folder as claimed in claim 1, wherein a conveyor is provided to cause relative longitudinal movement between the blade and the carton.
3. A rotatable flap folder as claimed in claim 1 or claim 2, wherein the helical blade can be adapted to serve as a static flap folding edge for a carton in translatory motion with respect to the blade.
4. A rotatable flap folder as claimed in any one of claims 1 to 3, wherein said helical blade is rotatable about the longitudinal axis thereby to urge the flap into face contacting relationship with an end of the carton.
5. A rotatable flap folder as claimed in any one of claims 1 to 4, wherein the folder is rotated in a reciprocating manner about its longitudinal axis.
6. A rotatable flap folder as claimed in any one of claims 1 to 4, wherein the outer face of the blade is arcuate.
7. A rotatable flap folder as claimed in claim 6, wherein the outer face is a substantially "U" shaped profile.

8. A method for closing a carton flap comprising disposing a carton having an extended carton flap adjacent a rotatable flap folder as claimed in any one of claims 1 to 7, wherein the extended carton flap is disposed proximate the helical edge: then rotating said helical blade to fold the flap adjacent the helical edge, and continue folding the flap by abutment with the outer arcuate face of the blade thereby to urge the carton flap into face-to-face relationship with an end of the carton.

9. The method as claimed in claim 8, wherein the helical blade is rotated about 90 degrees.

10. The method as claimed in claim 8 or claim 9, wherein prior to engagement of the carton by said helical blade adhesive is applied to an end wall of the carton to which the carton flap is to be pressed along a line which is coincident with a tangent line along which a cylindrical wall of said cylindrical segment structure contacts the carton.

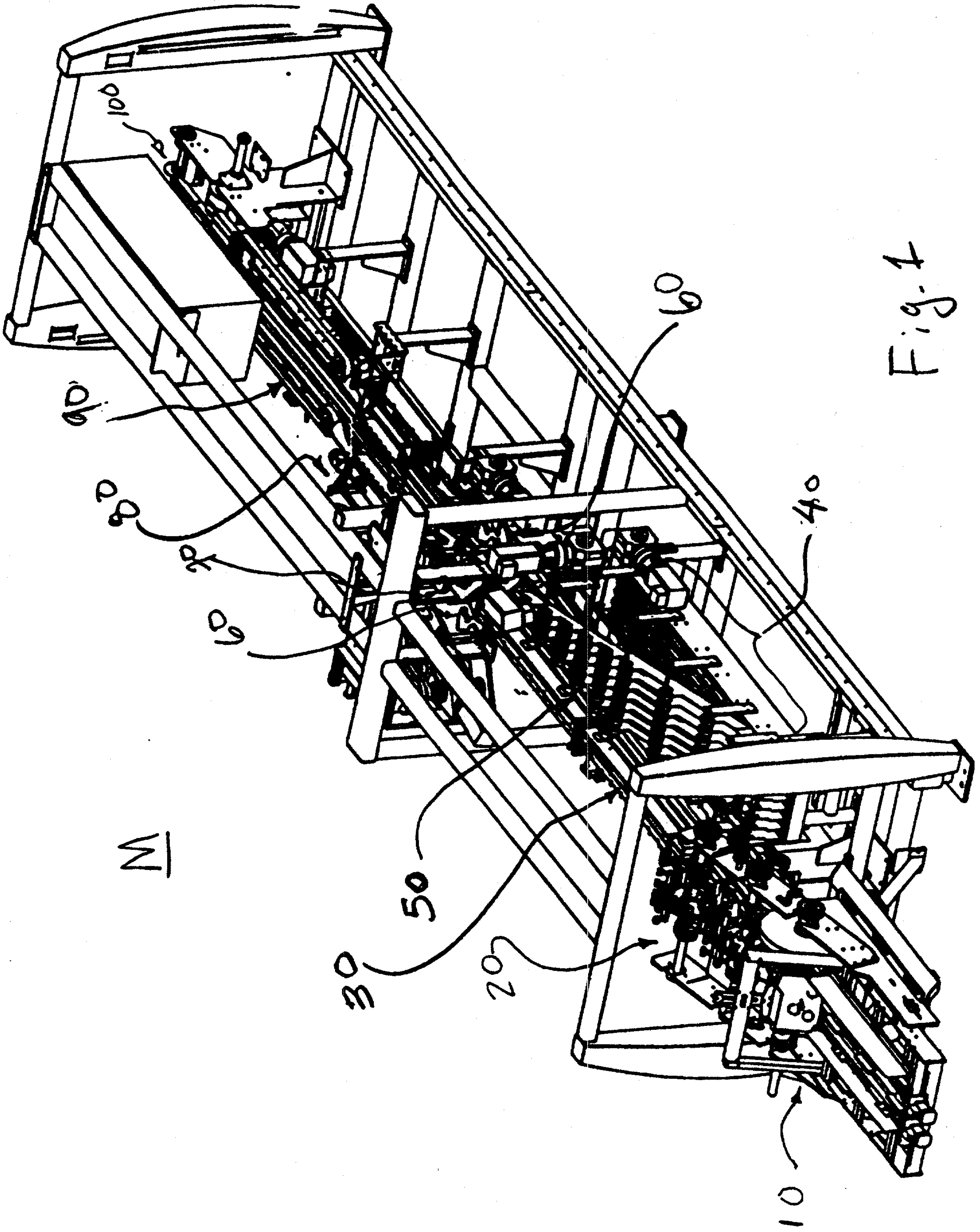

Fig. 1

