



(12) **EUROPEAN PATENT APPLICATION**

(43) Date of publication:
04.11.2009 Bulletin 2009/45

(51) Int Cl.:
F41A 33/02^(2006.01)

(21) Application number: **08008193.8**

(22) Date of filing: **29.04.2008**

(84) Designated Contracting States:
AT BE BG CH CY CZ DE DK EE ES FI FR GB GR HR HU IE IS IT LI LT LU LV MC MT NL NO PL PT RO SE SI SK TR
Designated Extension States:
AL BA MK RS

(72) Inventor: **Liao, Yin-Hsi Kangning St. Sijhih City Taipei County 221 (TW)**

(71) Applicant: **Guay Guay Trading Co., Ltd. Sijhih City T'ai pei County 221 (TW)**

(74) Representative: **Becker, Eberhard Patentanwälte Becker, Kurig, Straus Bavariastrasse 7 80336 München (DE)**

(54) **Impact indicator for shooting training**

(57) The present invention relates to an impact indicator (2) for shooting training, in which an impact indicator includes a pipe body (4), a light beam module (5) and a compression structure (6). A wall surface of the pipe body (4) is penetrated with holes (41), and the light beam module (5) is configured with a switch (51) and located at one end of the pipe body (4). The compression structure (6) is fitted with a piston (61) at one end remote from the light beam module (5), and a rod (62) is located at the

other end. Accordingly, when air currents are outwardly expelled from the interior of a gun barrel (3) and push the compression structure (6), then the rod (62) of the compression structure (6) activates the switch (51) of the light beam module (5), causing the light beam module (5) to emit a light beam, thereby improving the problem of impact indicators of the prior art being only able to maintain constant illumination. The present invention is thus provided with practical advancement to enable instantaneous indication of the shooting point of impact.

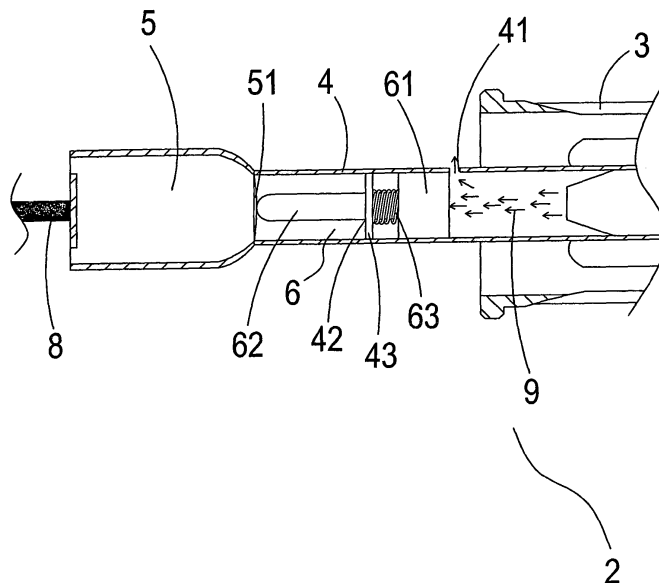

FIG.6

Description**BACKGROUND OF THE INVENTION****(a) Field of the Invention**

[0001] The present invention relates to an impact indicator, and more particularly to an impact indicator 2 for shooting training which is able to instantaneously indicate shooting point of impact.

(b) Description of the Prior Art

[0002] The acting out of survival games has already become a common leisure activity currently enjoyed by people, in which people handle toy guns to simulate actual field operations, and further simulate teaming up with others to act out the survival game, thereby cultivating an unvoiced pact between the players during gameplay, as well as achieving the effectiveness to provide recreation.

[0003] Furthermore, while acting out the survival game, in order to effectively aim at the hostile players in the game, players usually install a telescope on their gun barrels to observe the positions of the hostile players and additionally use an infrared sight to confirm the accurate position of what they are aiming at. Accordingly, aiming effectiveness is efficiently achieved when the light beam from the infrared sight shines on the position the player wants to shoot at.

[0004] Referring to FIG. 1, which shows an elevational view of an impact indicator of the prior art, and it can be clearly seen from the drawing that an impact indicator 1 is fitted to a predetermined gun barrel 11. A light beam module 12, which can be an infrared light, is connected to one end of the impact indicator 1; moreover, the light beam module 12 is configured with a switch 13, which is used to switch the light beam module 12 on or off. In order to use the impact indicator 1, it is directly fitted to the gun barrel 11, and the switch is used to switch on the light beam module 12. Accordingly, whatever position the gun barrel 11 is aiming at, then a light beam 14 emitted by the light beam module 12 is able to indicate the shooting point of impact.

[0005] However, the following problems and shortcomings are still in need of improvement when using the aforementioned impact indicator of the

prior art:

[0006] Although the impact indicator 1 of the prior art is able to clearly indicate the present position the gun barrel 11 is aiming at, however, during use, the light beam module 12 of the impact indicator 1 can actually only maintain constant illumination. Hence, regardless of whether the gun trigger has been pulled or not, all the players know what the gun barrel is presently aiming point, but are unable to know the when the gun trigger is

pulled and the exact shooting point of impact at that moment.

[0007] Hence, it is the strong desire of the inventor and manufacturers engaged in related art and purpose of the present invention to resolve and surmount existent technical difficulties to eliminate the problems and shortcomings of the aforementioned prior art.

SUMMARY OF THE INVENTION

[0008] Hence, in light of the shortcomings of the aforementioned prior art, the inventor of the present invention, having collected related data, and through evaluation and consideration from many aspects, as well as having accumulated years of experience in related arts, through continuous testing and improvements has designed a new impact indicator for shooting training which is able to instantaneously indicate shooting point of impact.

[0009] A primary objective of the present invention is to enable an impact indicator, comprising a pipe body, a light beam module and a compression structure, of the present invention to be fitted to a predetermined gun barrel; wherein one or more than one hole is defined in a wall surface of the pipe body, and an abutting wall provided with a through hole is located interior of the pipe body. The light beam module is located at one end of the pipe body and is configured with a switch. The compression structure penetrates the through hole of the abutting wall, and the compression structure is fitted with a piston at one end remote from the light beam module, and a rod is located at the other end. Furthermore, an elastic member is located between the piston and the abutting wall, which enables air currents flowing from the gun barrel to compress the compression structure when a person pulls the gun trigger. Because size of the piston is commensurate with the inner caliber of the gun barrel, thus, air currents are able to impel the compression structure and force the rod of the compression structure to activate the switch of the light beam module, and thereby cause the light beam module to emit a light beam. Moreover, when the piston is displaced to the position of the hole of the gun barrel, then the air currents are able to be expelled out the hole. Furthermore, when the elastic member between the piston and the abutting wall is elastically released, then the compression structure is forcibly displaced back to its original position. Accordingly, when the user pulls the gun trigger, thereby causing air currents to be expelled from the gun barrel, then the current accurate point of impact can be instantaneously known. Accordingly, use of the aforementioned art resolves the problem of the constant illumination of the infrared ray indicator of the prior art impact indicator, thereby achieving practical advancement to enable instantaneous indication of the shooting point of impact.

[0010] Another objective of the present invention lies in the one or more than one hole penetrating the wall surface of the pipe body, and for the piston of the compression structure to be further configured with a movable

span, with a displacement rod penetrating the movable span. Furthermore, an adjuster is annular located on the pipe body, and the adjuster is pin connected to the displacement rod. The adjuster can be a nut, thereby enabling adjustment of the adjuster to displace the displacement rod and cause the compression structure to be correspondingly directionally displaced, and thus cause the rod of the compression structure to constantly press on the switch of the light beam module, and further cause the light beam module to maintain constant illumination. Moreover, the adjuster can be displaced to adjust the size of the hole according to different lengths of the gun barrel, thereby further achieving the effectiveness to adjust sensitivity of the light beam module. Accordingly, use of the aforementioned art enables the light beam module of the impact indicator of the present invention to produce constant illumination and freely adjust sensitivity of the light beam module, and achieve practical advancement not considered in impact indicators of the prior art.

[0011] To enable a further understanding of said objectives and the technological methods of the invention herein, a brief description of the drawings is provided below followed by a detailed description of the

preferred embodiments.

BRIEF DESCRIPTION OF THE DRAWINGS

[0012]

FIG. 1 shows an elevational view of an impact indicator of the prior art.

FIG. 2 shows an elevational view of a preferred embodiment of the present invention.

FIG. 3 shows a cutaway view of the preferred embodiment of the present invention.

FIG. 4 shows a first schematic view depicting operation of the preferred embodiment according to present invention movement.

FIG. 5 shows a second schematic view depicting operation of the preferred embodiment according to present invention movement.

FIG. 6 shows a third schematic view depicting operation of the preferred embodiment according to present invention movement.

FIG. 7 shows a fourth schematic view depicting operation of the preferred embodiment according to present invention movement.

FIG. 8 shows a cutaway view of another preferred embodiment of the present invention.

FIG. 9 shows a first schematic view depicting operation of yet another preferred embodiment according to the present invention.

FIG. 10 shows a second schematic view depicting operation of yet another preferred embodiment according to the present invention.

DETAILED DESCRIPTION OF THE PREFERRED EMBODIMENTS

[0013] Referring to FIG. 2 and FIG. 3, which show an elevational view and a cutaway view of a preferred embodiment respectively of the present invention, and it can be clearly seen from the drawings that an impact indicator 2 of the present invention is fitted to a predetermined gun barrel 3, and comprises:

A pipe body 4, in which one or more than one hole 41 penetrates a wall surface of the pipe body 4, and the pipe body 4 is internally configured with an abutting wall 43 provided with a through hole 42.

A light beam module 5, which is located on one end of the pipe body 4, is configured with a switch 51.

A compression structure 6, which penetrates the through hole 42 of the abutting wall 43; moreover, the compression structure 6 is fitted with a piston 61 located at one end remote from the light beam module 5, and a rod 62 is located at the other end. An elastic member 63 is located between the piston 61 and the abutting wall 43. The elastic member 63 can be either a spring, an elastic flat bar or a related member provided with elasticity.

[0014] According to the aforementioned structure and constructional design, circumstances during operational use of the present invention are described hereinafter.

Referring together to FIG. 4, FIG. 5, FIG. 6 and

[0015] FIG. 7, which show schematic views 1 to 4 depicting operations of the preferred embodiment respectively according to the present invention, and it can be clearly seen from the drawings that the impact indicator 2 of the present invention is fitted to the predetermined gun barrel 3, and the pipe body 4 is fitted with one or more than one elastic ring member 44, which are used to firmly install the impact indicator 2 in the gun barrel 3.

Accordingly, when the gun trigger is pulled, air currents 9 within the gun barrel 3 are outwardly expelled and impel the compression structure 6 to force the rod 62 of the compression structure 6 to activate the switch 51 of the light beam module 5, thereby causing the light beam module 5 to emit a light beam 8. Moreover, when the piston 61 has been displaced past the hole 41 of the gun barrel 3, then the air currents 9 are able to effuse from the hole 41, and at the same time the pressure within the gun barrel 3 is quickly dissipated. Furthermore, release of the elastic force of the elastic member 63 between the piston 61 and the abutting wall 43 forces the compression structure 6 to move back to its original position.

Accordingly, when the user pulls the gun trigger, causing the air currents 9 to be expelled from the gun barrel 3, then the current accurate point of impact can be instantaneously known. Moreover, the user can fit the impact indicator 2 of the present invention to equipment used in shooting training and used in conjunction with a detector, thereby enabling the user know that he has really pulled the gun

trigger when the light beam 8 illuminates the detector, and thus achieve practical advancement for accurate aiming during shooting training.

[0016] Referring to FIG. 8, which shows cutaway views of another preferred embodiment of the present invention, and it can be clearly seen from the drawings that the rod 62 of the present invention can be further joined to a stop piece 64 that is larger than the through hole 42. A contracted restricting section 46 can be further provided on the pipe body 4 at an appropriate position, or one or more than one protruding piece 47 can be further annular located within the pipe body 4, thereby enabling the aforementioned structures to be used to prevent the compression structure 6 from falling into the gun barrel 3.

[0017] Referring together to FIG. 9 and FIG. 10, which show a first and second schematic view of another preferred embodiment respectively depicting operations of the present invention movement, and it can be clearly seen from the drawings that the piston 61 of the present invention can be further provided with a movable span 65, and a displacement rod 66 penetrates the movable span 65. Furthermore, an adjuster 45 is annular located on the pipe body 4, and the adjuster 45 is pin connected to the displacement rod 66. The adjuster 45 can be a nut, thereby enabling adjustment of the adjuster 45 to displace the displacement rod 66 and cause the compression structure 6 to be correspondingly directionally displaced, and thus cause the rod 62 of the compression structure 6 to constantly press on the switch 51 of the light beam module 5, and further cause the light beam module 5 to maintain constant illumination, or the adjuster 45 can be displaced to adjust the size of the hole 41 according to different lengths of the gun barrel 3, thereby further achieving the effectiveness to adjust sensitivity of the light beam module 5. Accordingly, use of the aforementioned art enables the present invention to freely adjust the light beam module 5 to produce constant illumination or freely adjust sensitivity of the light beam module 5.

[0018] In addition, a counter 7 can be further located within the light beam module 5 of the impact indicator 2 of the present invention, with the counter 7 being connected to the switch 51. Accordingly, disposition of the counter 7 is used to learn of the current number of times the light beam module 5 has been activated by way of the switch 51, and additionally learn of the number of times the user has pulled the gun trigger. Furthermore, the counter 7 can be set with a default number, and when the counter 7 has reached the preset number, then the counter 7 can control and stop the light beam module 5 from emitting light, thereby achieving limiting the number of times that the light beam module 5 is activated.

[0019] Hence, referring to all the drawings, compared to the prior art, the following advantages exist when using the present invention:

1. The present invention comprises the pipe body 4, the light beam module 5 and the compression struc-

ture 6, which, when the air currents 9 are expelled from the gun barrel 3 and compress the compression structure 6, then the rod 62 of the compression structure 6 is able to activate the switch 51 of the light beam module 5, thereby causing the light beam module 5 to emit the light beam 8. Moreover, when the piston 61 is displaced to the position of the hole 41 of the gun barrel 3, then the air currents 9 are able to be expelled out the hole 41. Furthermore, when the elastic member 63 between the piston 61 and the abutting wall 43 is elastically released, then the compression structure 6 is forcibly displaced back to its original position, thereby achieving practical advancement to enable instantaneous indication of the shooting point of impact.

2. The piston 61 of the impact indicator 2 of the present invention can be further configured with the movable span 65, with the displacement rod 66 penetrating the movable span 65.

[0020] Furthermore, the adjuster 45 is annular located on the pipe body 4 and pin connected to the displacement rod 66, thereby enabling adjustment of the adjuster 45 to displace the displacement rod 66 and cause the compression structure 6 to be correspondingly directionally displaced. Accordingly, the light beam module 5 is able to produce constant illumination, and adjustment of the adjuster 45 can be used to further adjust the size of the hole 41 to accommodate different lengths of the gun barrel 3, thereby achieving the effectiveness to adjust sensitivity of the present invention.

[0021] In conclusion, the impact indicator for shooting training of the present invention is clearly able to achieve effectiveness and objectives when in use, and is indeed a practical and exceptional invention that complies with the essential elements as required for a new patent application. Accordingly, a new patent application is proposed herein.

[0022] It is of course to be understood that the embodiments described herein are merely illustrative of the principles of the invention and that a wide variety of modifications thereto may be effected by persons skilled in the art without departing from the spirit and scope of the invention as set forth in the following claims.

Claims

1. An impact indicator for shooting training; the impact indicator 2 being fitted to a predetermined gun barrel 3, and comprises:

a pipe body 4, wherein one or more than one hole 41 penetrates a wall surface of the pipe body 4, and the pipe body is internally configured with an abutting wall 43 provided with a through hole 42;
a light beam module 5 located on one end of the

- pipe body 4 and
 configured with a switch 51;
 a compression structure 6 that penetrates the
 through hole 42 of the abutting wall 43, the com-
 pression structure 6 is fitted with a piston 61 lo- 5
 cated at one end remote from the light beam
 module 5, and a rod 62 is located at the other
 end, moreover, an elastic member 63 is located
 between the piston 61 and the abutting wall 43. 10
2. The impact indicator for shooting training according
 to claim 1, wherein the rod 62 is further connected
 to a stop piece 64 larger than the through hole 42.
3. The impact indicator for shooting training according 15
 to claim 1, wherein the pipe body 4 is further config-
 ured with a contracted restricting section 46 at an
 appropriate position thereof.
4. The impact indicator for shooting training according 20
 to claim 1, wherein one or more than one protruding
 piece 47 is further annular located within the pipe
 body 4.
5. The impact indicator for shooting training according 25
 to claim 1, wherein the elastic member 63 is either
 a spring, an elastic flat bar or a related member pro-
 vided with elasticity.
6. The impact indicator for shooting training according 30
 to claim 1, wherein the piston 61 is further provided
 with a movable span 65, and a displacement rod 66
 penetrates the movable span 65, moreover, an ad-
 juster 45 is annular located on the pipe body 4, and 35
 the adjuster 45 is pin connected to the displacement
 rod 66.
7. The impact indicator for shooting training according 40
 to claim 1, wherein the pipe body 4 is fitted with one
 or more than one elastic ring member 44.
8. The impact indicator for shooting training according 45
 to claim 1, wherein the light beam module 5 is further
 configured with a counter 7, and the counter 7 is
 connected to the switch 51.

50

55

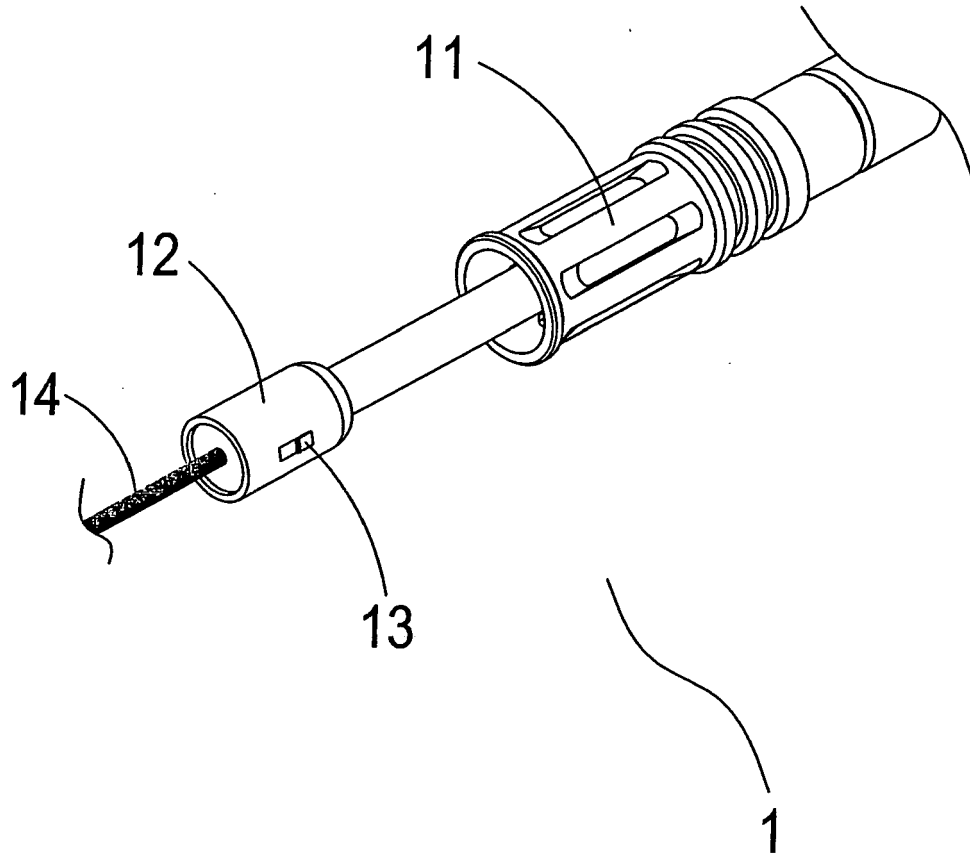

FIG.1
Prior Art

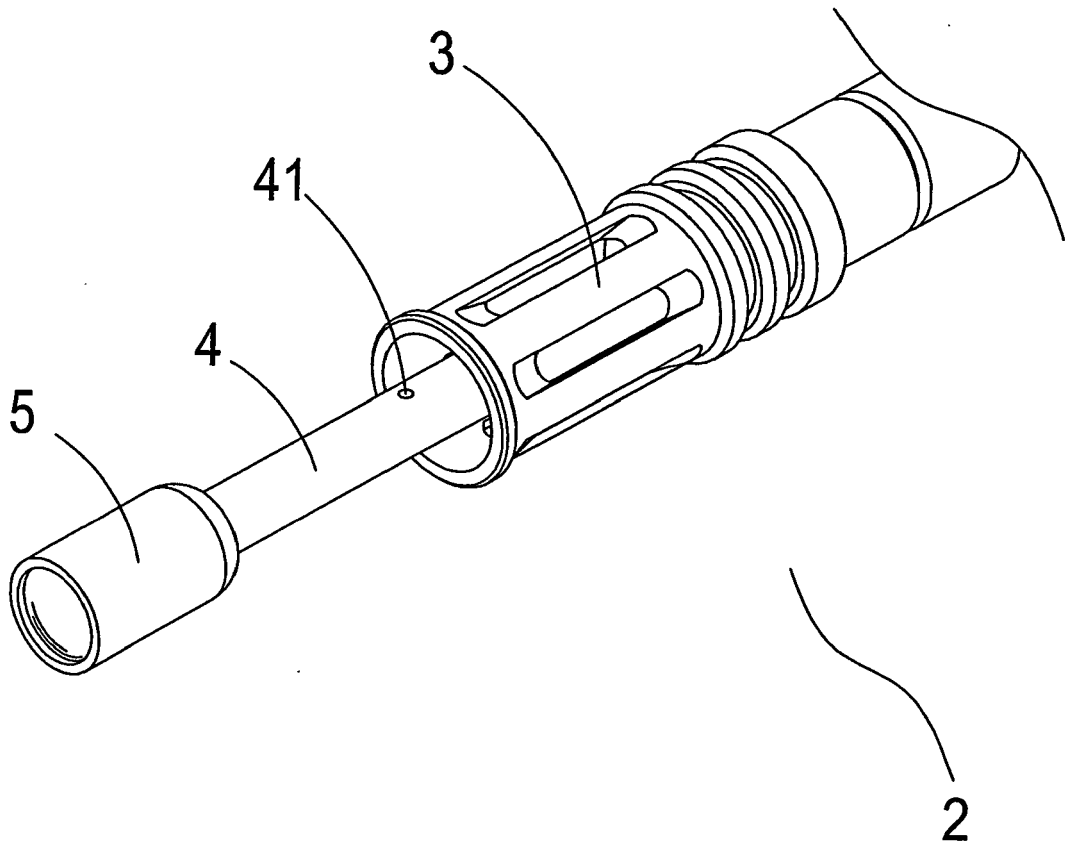

FIG.2

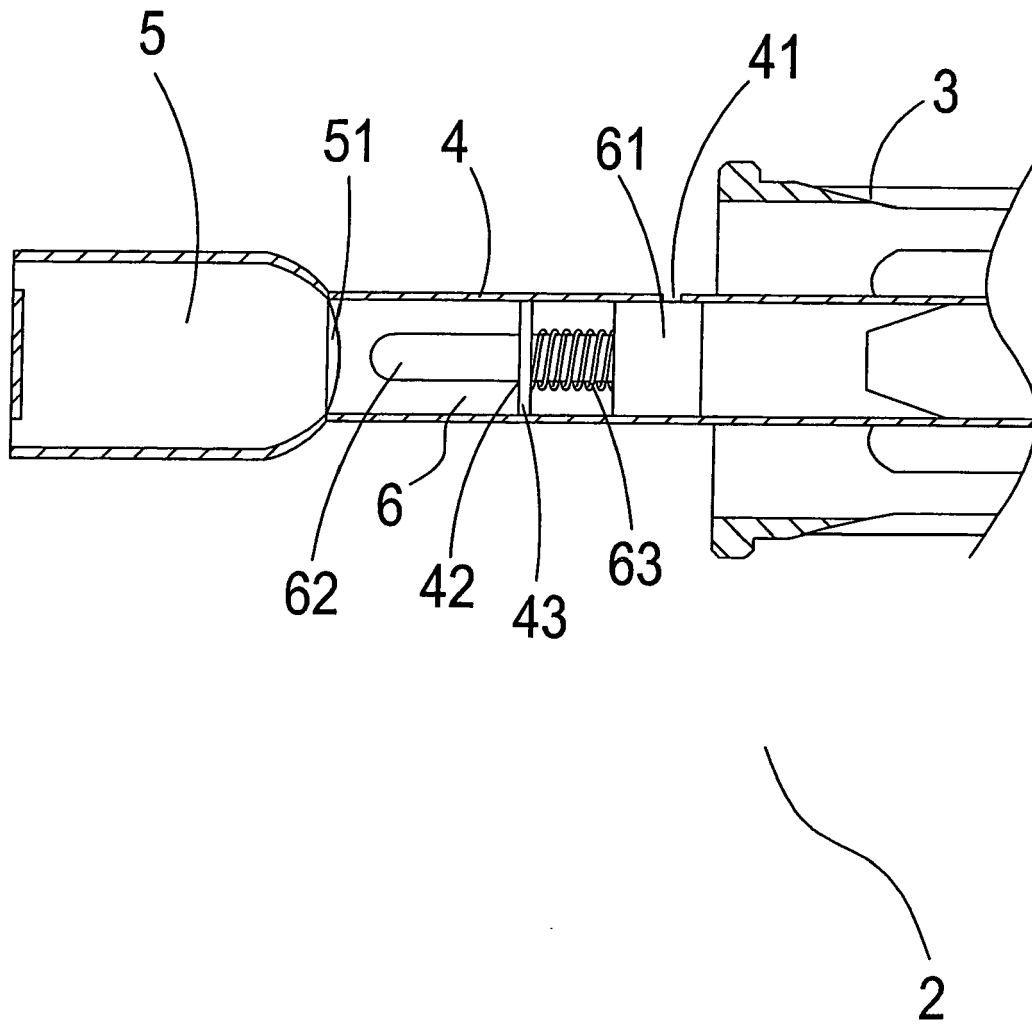

FIG.3

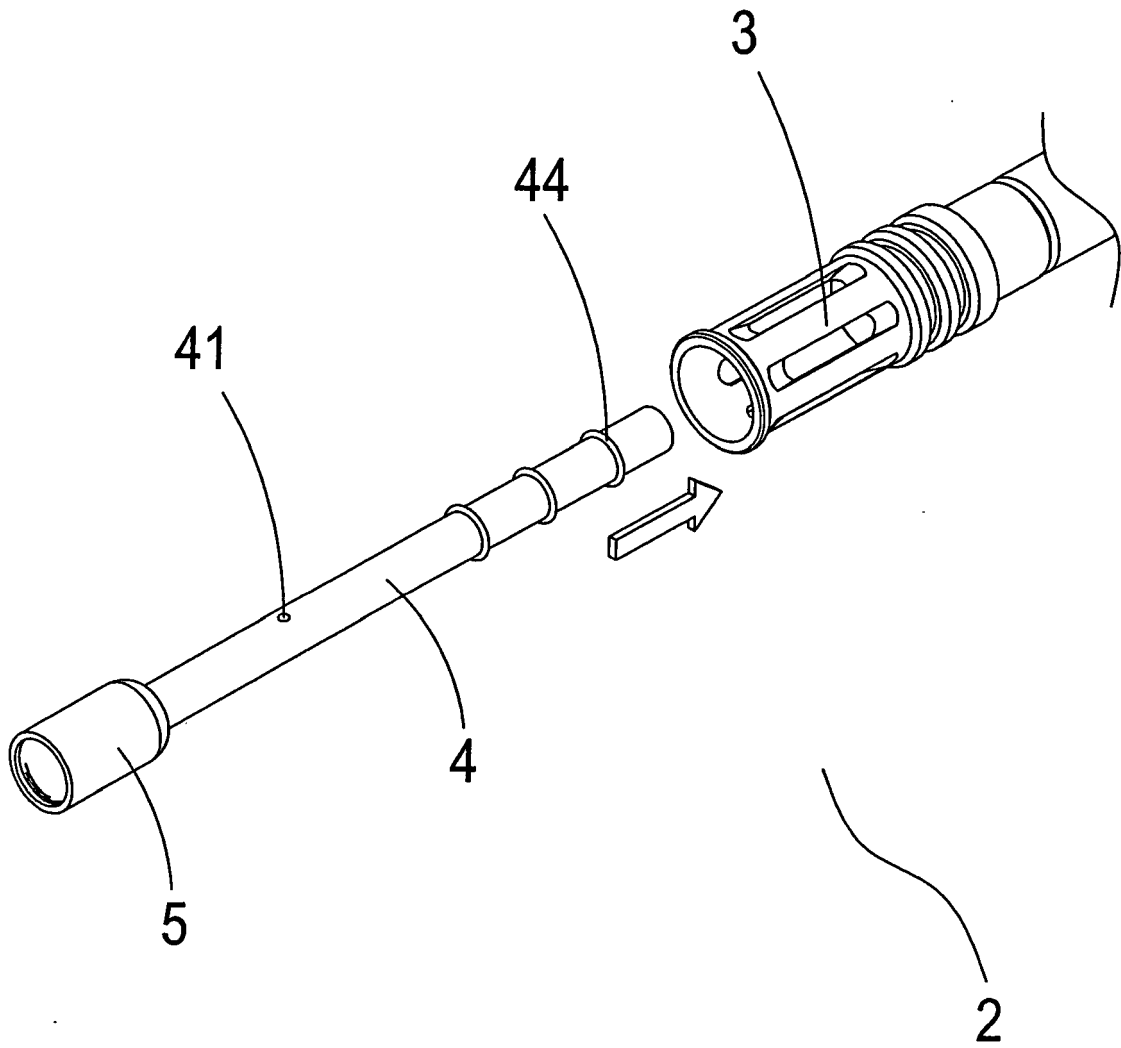

FIG.4

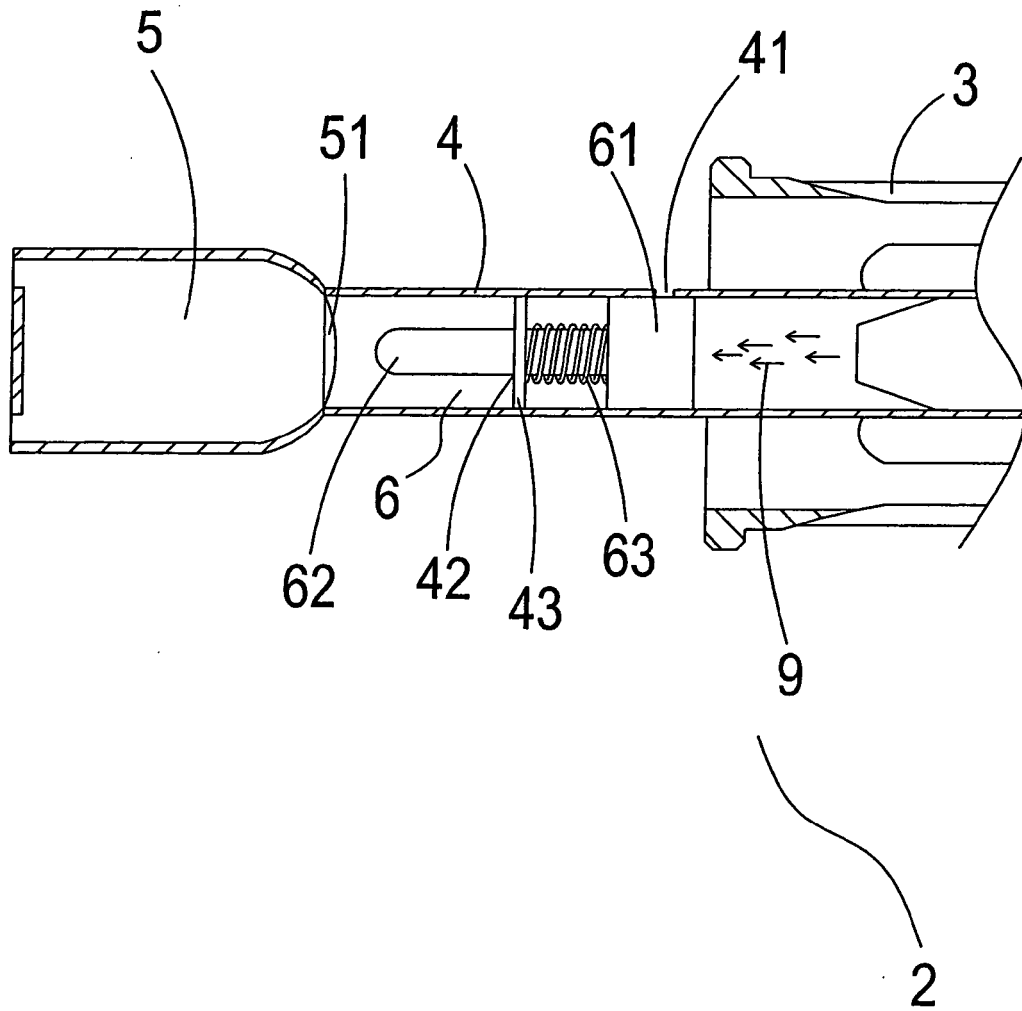

FIG.5

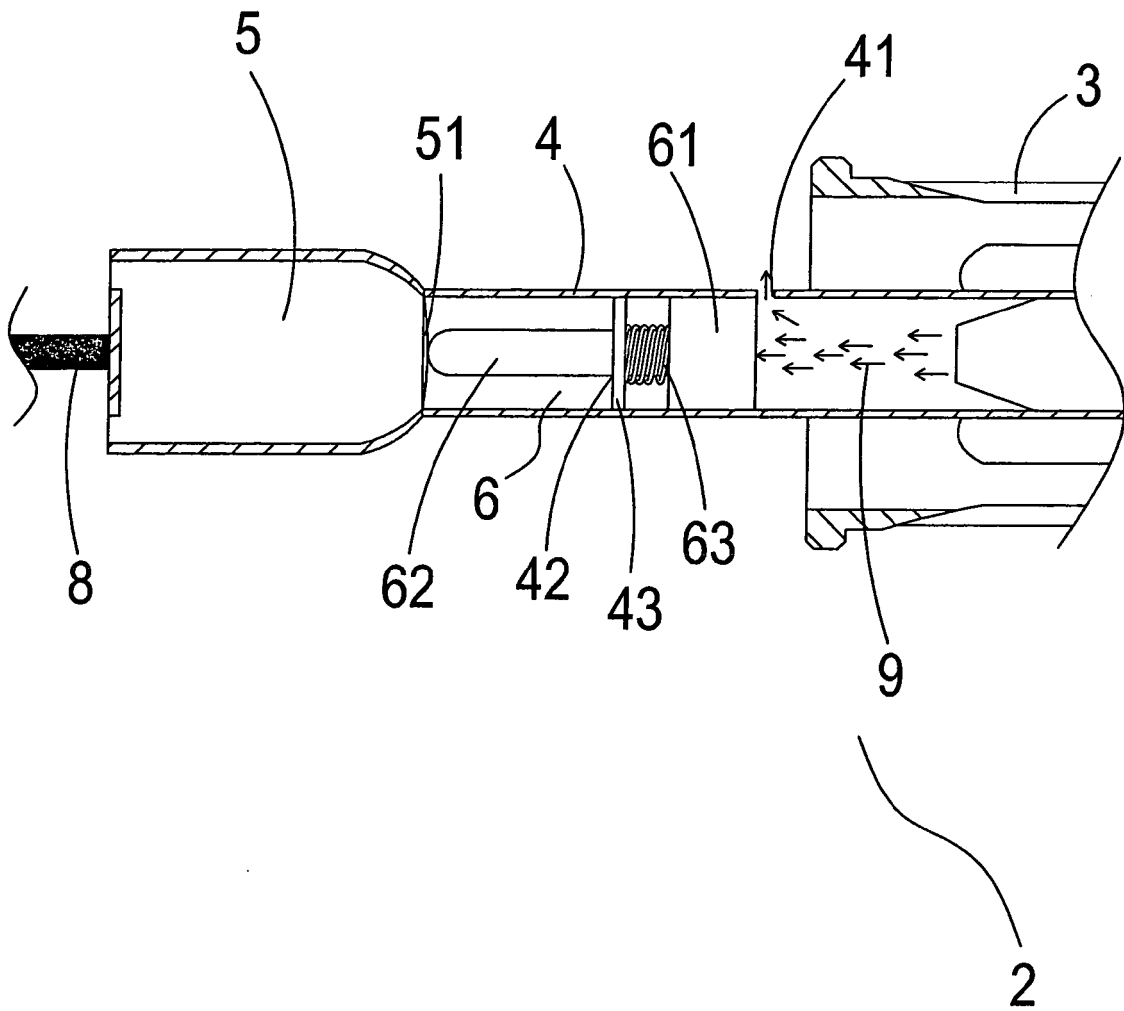

FIG.6

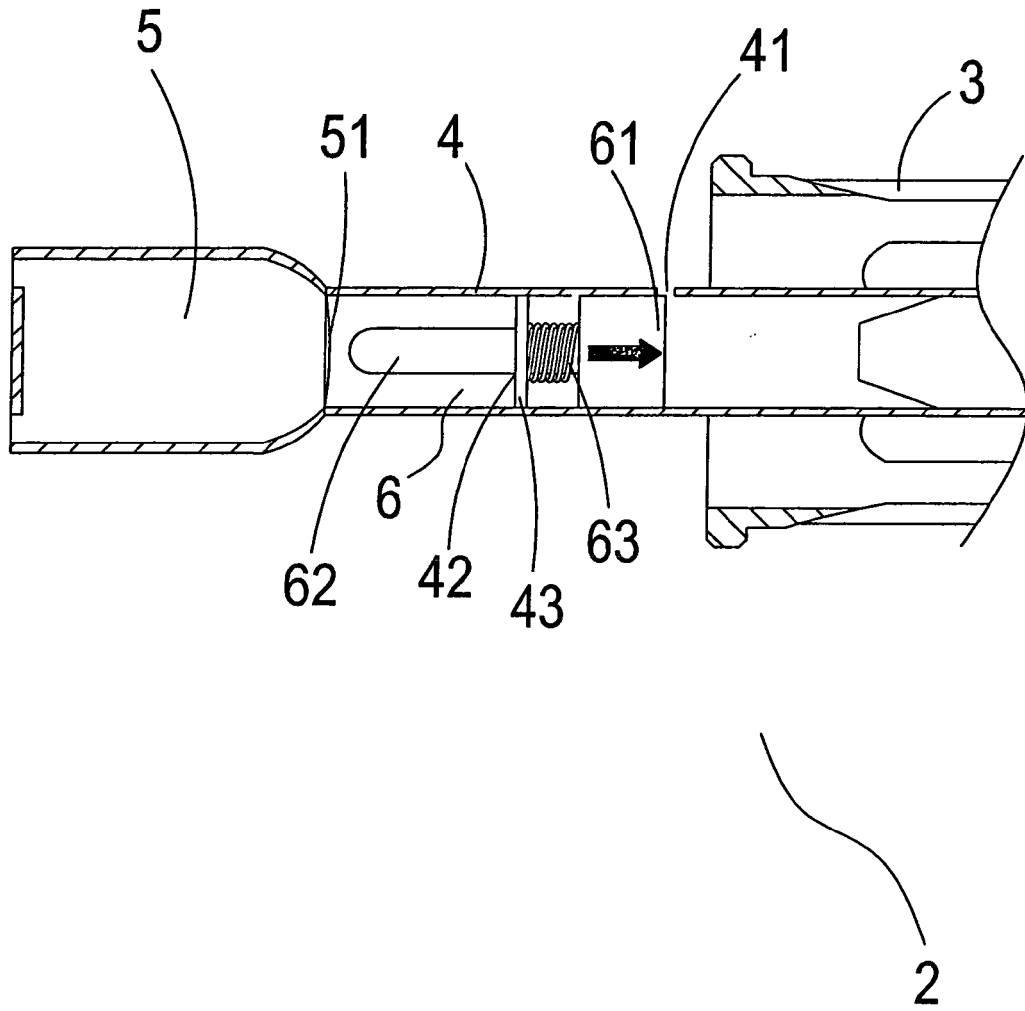

FIG.7

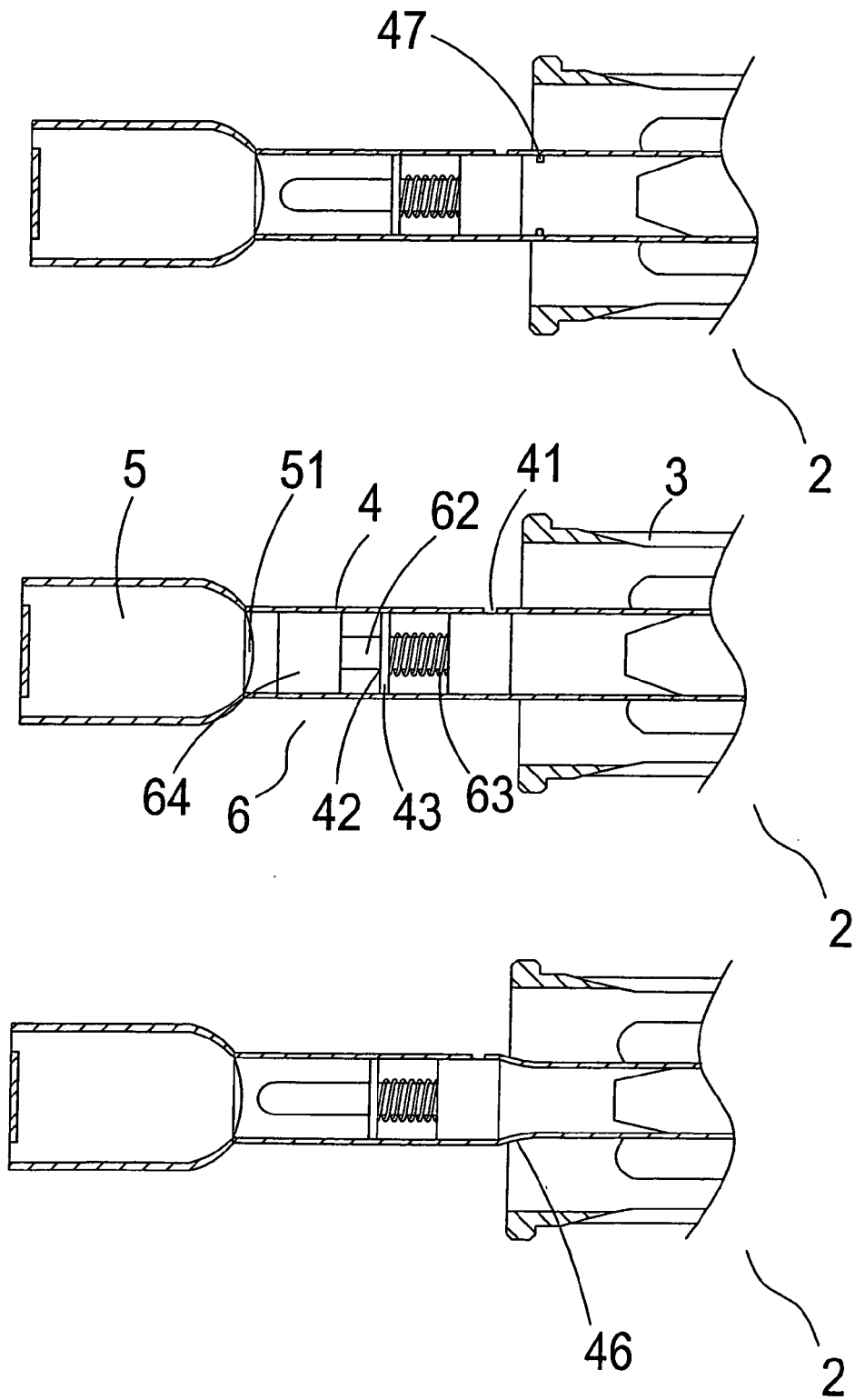

FIG.8

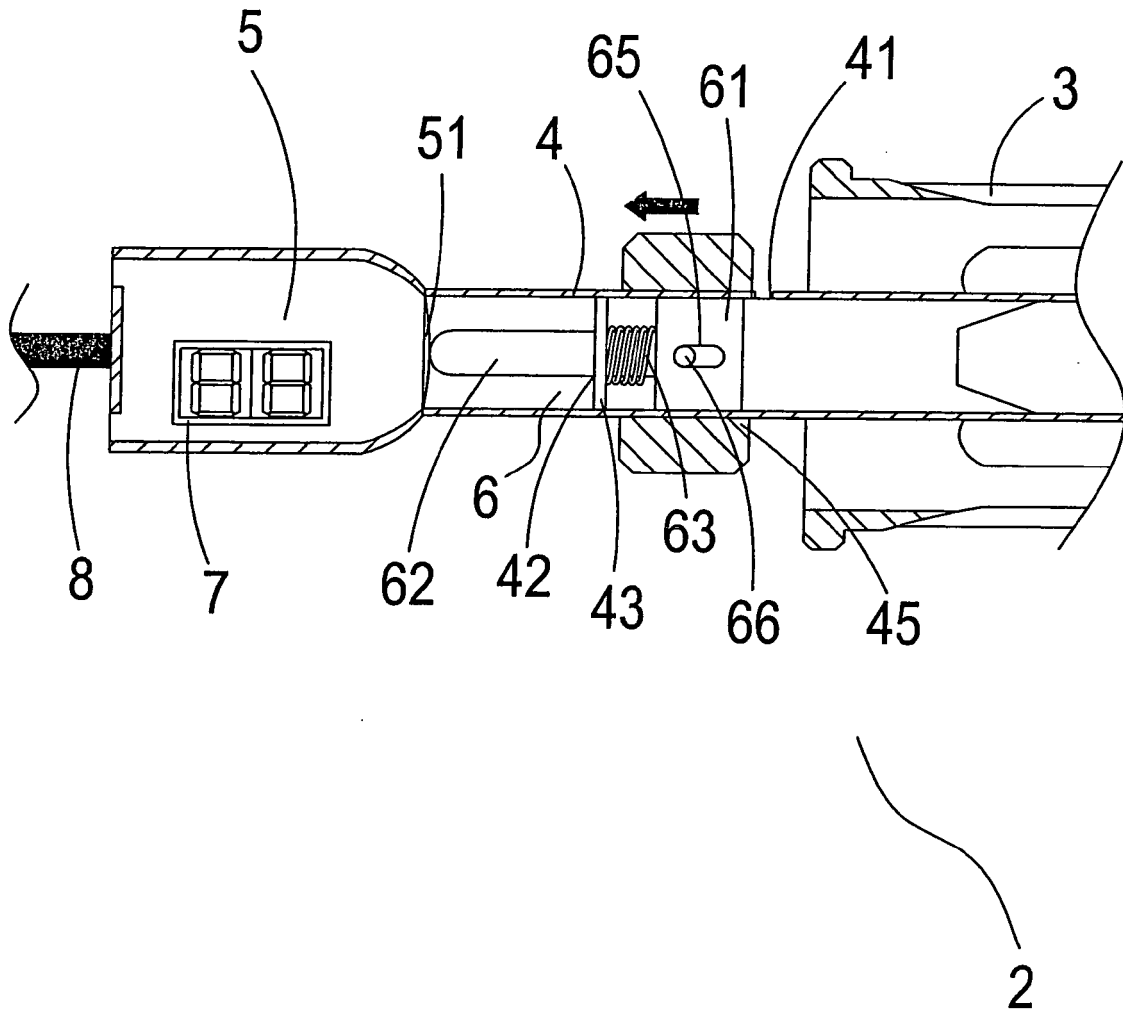

FIG.9

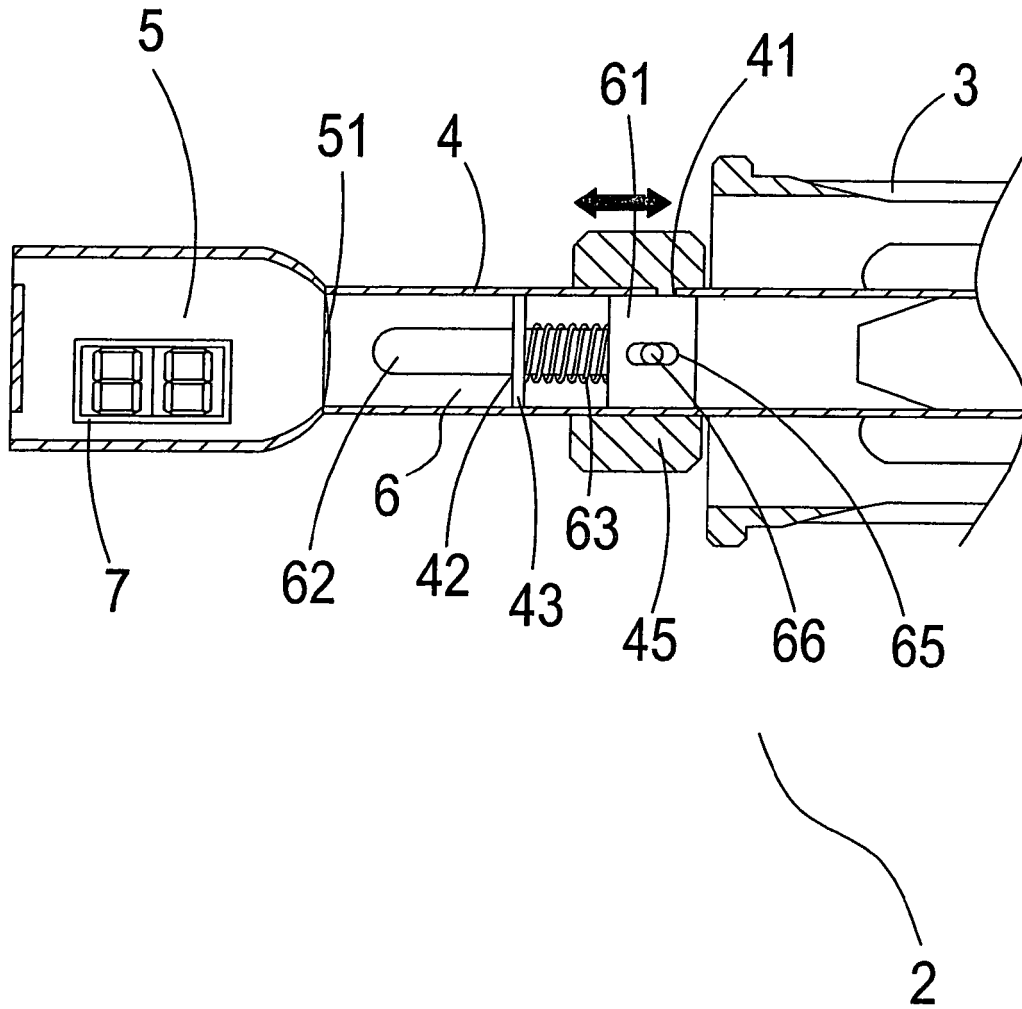

FIG.10



EUROPEAN SEARCH REPORT

 Application Number
 EP 08 00 8193

DOCUMENTS CONSIDERED TO BE RELEVANT			
Category	Citation of document with indication, where appropriate, of relevant passages	Relevant to claim	CLASSIFICATION OF THE APPLICATION (IPC)
X	US 4 983 123 A (SCOTT BENTLEY N [US] ET AL) 8 January 1991 (1991-01-08) * abstract; figure 1 * * column 3, line 5 - column 5, line 5 * -----	1-5,7,8	INV. F41A33/02
X	JP 2000 266498 A (TOKYO MARUI KK) 29 September 2000 (2000-09-29) * abstract; figures 1-6 * -----	1	
A	DE 38 38 089 A1 (DIEHL GMBH & CO [DE]) 17 May 1990 (1990-05-17) * abstract; figure 1 * * column 1, line 52 - line 68 * -----	1	
A	GB 2 351 143 A (BATES P [GB]; MORLEY J [GB]; SNELLFLIGHT LTD [GB] BATES P [GB]; MORLEY) 20 December 2000 (2000-12-20) * abstract; figure 1 * -----	8	
The present search report has been drawn up for all claims			TECHNICAL FIELDS SEARCHED (IPC)
			F41A F41G
Place of search		Date of completion of the search	Examiner
The Hague		7 October 2008	Schwingel, Dirk
CATEGORY OF CITED DOCUMENTS			
X : particularly relevant if taken alone Y : particularly relevant if combined with another document of the same category A : technological background O : non-written disclosure P : intermediate document		T : theory or principle underlying the invention E : earlier patent document, but published on, or after the filing date D : document cited in the application L : document cited for other reasons & : member of the same patent family, corresponding document	

 1
 EPO FORM 1503 03.02 (P04C01)

ANNEX TO THE EUROPEAN SEARCH REPORT
ON EUROPEAN PATENT APPLICATION NO.

EP 08 00 8193

This annex lists the patent family members relating to the patent documents cited in the above-mentioned European search report. The members are as contained in the European Patent Office EDP file on
The European Patent Office is in no way liable for these particulars which are merely given for the purpose of information.

07-10-2008

Patent document cited in search report	Publication date	Patent family member(s)	Publication date
US 4983123 A	08-01-1991	NONE	
JP 2000266498 A	29-09-2000	JP 3034518 B2	17-04-2000
DE 3838089 A1	17-05-1990	NONE	
GB 2351143 A	20-12-2000	NONE	