

J. P. FULGHAM.  
Corn-Drill.

No. 199,820.

Patented Jan. 29, 1878.

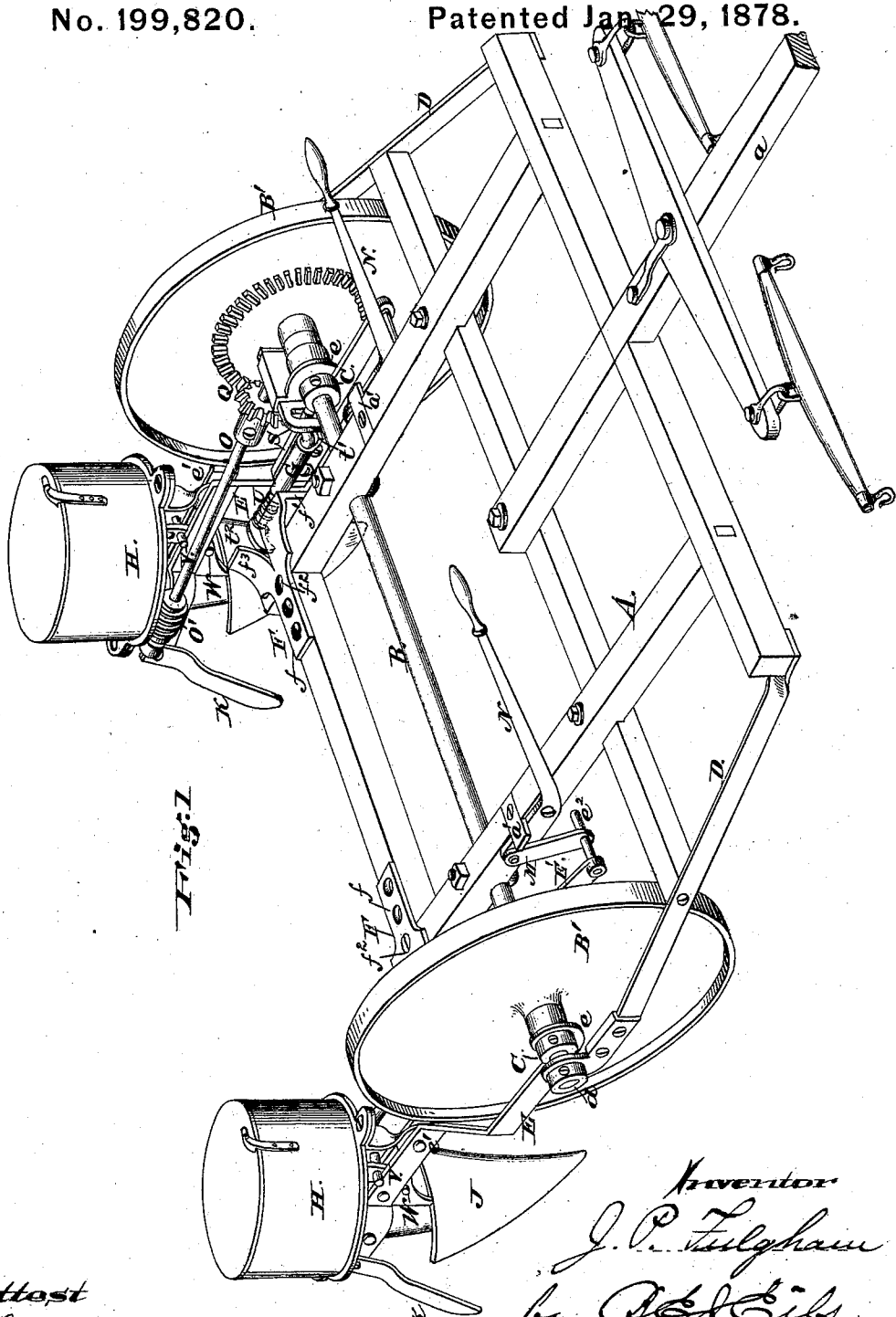

Fig. 1

attest  
Wm. A. Meale  
H. D. Perine

Inventor  
J. P. Fulgham  
by A. J. Ellis  
Attorney

J. P. FULGHAM.  
Corn-Drill.

No. 199,820.

Patented Jan. 29, 1878.

Fig. 2

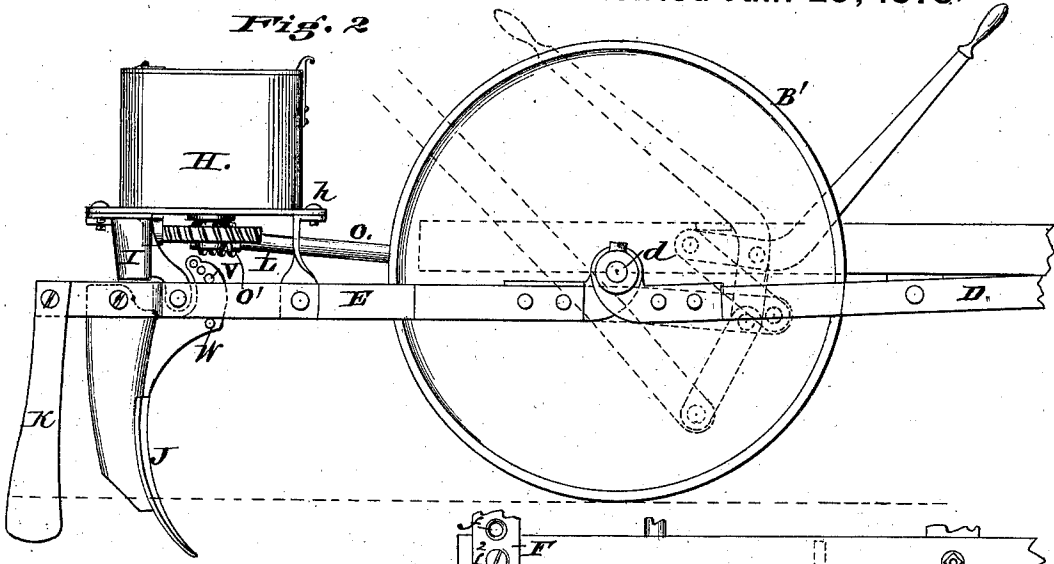

Fig. 3

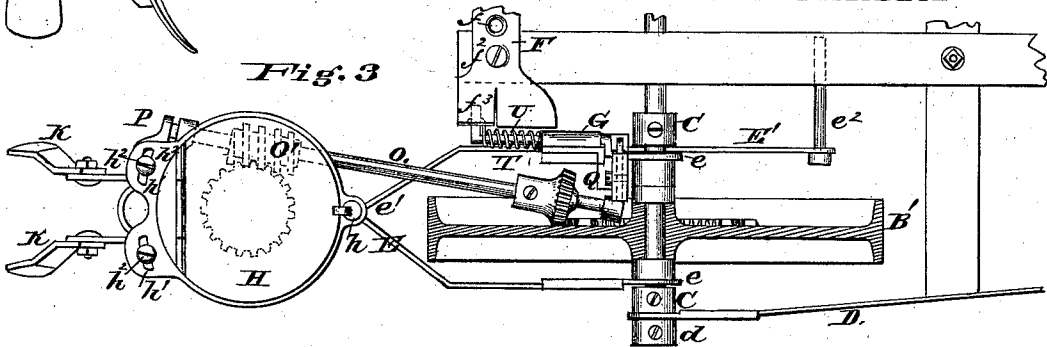
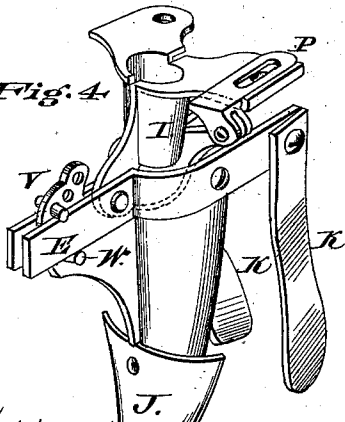

Fig. 4



Attest

W. L. Penne

W. L. Penne

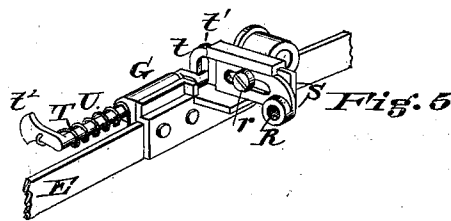

Fig. 5

Inventor

J. P. Fulgham

by W. L. Penne

Attorney

# UNITED STATES PATENT OFFICE.

JESSE P. FULGHAM, OF MILTON, INDIANA, ASSIGNOR TO HOOSIER DRILL COMPANY, OF SAME PLACE.

## IMPROVEMENT IN CORN-DRILLS.

Specification forming part of Letters Patent No. **199,820**, dated January 29, 1878; application filed June 23, 1877.

*To all whom it may concern:*

Be it known that I, JESSE P. FULGHAM, of Milton, Wayne county, State of Indiana, have invented an Improvement in Corn-Drills, of which the following is a specification:

My invention relates to the class of corn-planters known as "double-row corn-planters"—that is, machines adapted to drill two rows of corn at the same time.

My invention consists, in the first part, in a new organization of parts, consisting of the following elements and relative arrangement: first, a main frame, to which the horses are attached, mounted on two wheels running upon a single axle; second, two secondary frames, one to each ground-wheel, each secondary frame being coupled to the axle of the ground-wheel to swing thereon, and having all the operative parts of a corn-planter—to wit, a furrow-opener, grain-tube, covering-shares, seed-hopper, and dropper-plate devices—attached thereto, so that as the machine progresses in the field all these parts preserve the same relation to each other, no matter what depth the furrow-opener may run in the ground; third, a driving-connection between the ground-wheel and seed-dropper, adapted to swing with the secondary frame to follow the undulations of the ground without the displacement of any of its parts, the dropping-plate and the gear or other device which connects with the ground-wheel to drive the dropper being attached rigidly to one and the same frame.

My invention consists, in the second part, of a device for enabling the operator to set the two planters at any one of a number of predetermined distances apart without measurement.

In the accompanying drawings, Figure 1 is a perspective view of my machine. Fig. 2 is a side elevation. Fig. 3 is a plan, partly in section. Fig. 4 is a perspective view of grain-spout, furrow-opener, and covering-shares. Fig. 5 is a perspective view of the device for throwing the driving-connection out of gear, and the device for adjusting the running depth of the teeth on the ground-wheel.

A is the main frame, to which is attached a stationary axle, B. A driver's seat is to be attached at the rear end of the pole *a*, so located as that the frame may tilt downward at the forward end, and cause the tongue to rest lightly on the horses' necks.

On the axle B two ground-wheels, B', rotate, these wheels having each a ring of teeth for operating the dropper-plates. The wheels are laterally adjustable on the axle, and are retained at the different points of adjustment by sliding collars C, fitted with retaining set-screws. The outer ends of the axle are braced by the straps D, each having an eye, *d*, to inclose the end of the axle.

E and E are the secondary frames, wholly independent of each other, provided with eyes *e*, which loosely fit and swivel on the axle B. Each frame is forked at *e'* to straddle the ground-wheel, and its eyes *e* fit in between the hub or collars of the ground-wheel and the adjusting-collars C, so that when the collars are moved to adjust the width of the rows the frame and wheel move together, and retain the same relations to each other.

On the frame A, at each side, I secure an adjustable plate, F, having a series of holes, *f*, a certain distance—say one inch—apart. This plate has a flange, *f'*, turned down, against which the bearing G on the secondary frame E may come in contact.

To change the width of the rows, the collars C are slackened, and the plates F moved so that their fastening-screws *f*<sup>2</sup> are placed in different holes. When these plates are secured in the new position the secondary frames are moved in so that the bearings G touch the flanges *f'*, and the collars C are then secured, and owing to the means of adjusting the plates F, being a series of holes at a known distance apart, the operator is enabled to increase or decrease the width of his rows apart a definite distance without measurement.

Each secondary frame E carries a seed-box, H, grain-tube I, furrow-opener J, covering-shares K, and dropper-plate in the seed-box, operated by gear-wheel L, and these being all attached to the same frame, they are pre-

served in the same relation to each other, while the frame on which they are carried is permitted to follow the undulations of the ground, and its furrow-opener to have a varying running depth.

Each secondary frame has an extension-bar,  $E'$ , bearing a pin,  $e^2$ , which fits and slides through a link,  $M$ , pivoted to the short end of bent lever  $N$ .

The driver operates the levers  $N$  from his seat on the main frame, and by them raises the planters out of the ground for transportation of the machine from field to field, or for other purposes; and by reason of the peculiar arrangement of the link and bent lever, as shown in Fig. 2, they lock past center when the planter is up, and support it in that position, the lever resting against a stop,  $a'$ .

In the other position the planter is allowed to follow the undulations of the ground freely.

The driving-shaft  $O$  to each planter has a worm,  $O'$ , to drive the wheel  $L$ , and is journaled at one end under the seed-box in a bearing-plate,  $P$ , which is secured to the box by a single screw,  $h^2$ , on which it may slide, and on which it pivots when the screw is slackened. This sliding feature gives an adjustable end bearing to the shaft, to take up wear, and the pivoting enables the running depth of the worm in the wheel to be delicately adjusted. The other end of this shaft has a pinion,  $Q$ , which gears into the ring of teeth on the ground-wheel, and the shaft is journaled in the plate  $R$ , which is adjustably secured in the sliding block  $S$ , which moves in a lateral extension of the secondary frame.

The plate  $R$  is secured in plate  $S$  by a bolt,  $r$ , and its adjustment enables the operator to delicately adjust the running depth of the teeth of the pinion  $Q$  in the teeth of the ground-wheel. These teeth may be thrown entirely out of gear by the following device: The bearing  $G$  has journaled in it a shaft,  $T$ , with a crank-arm,  $t$ , at one end, moving in a vertical slot,  $t^1$ , in the slide  $S$ . The other end of the shaft has a trigger-arm,  $t^2$ , which, when the planter is lifted, is caused to swing by impinging against the inclined plane or cam surface  $f^3$  on plate  $F$ , and by this means the crank  $t$  is turned and the slide  $S$  moved so as to disengage the teeth of the pinion from the teeth of the ground-wheel. A coiled spring,  $U$ , returns the teeth into proper mesh when the planter is returning to a working position.

As a preferred means of adjusting the running depth of the teeth of the worm, I pivot the seed-box  $H$  at  $h$ , and secure it at the other side by screws  $h^3$ , passing into the secondary frame through slots  $h^1$ . By slacking these

screws the box may be swung laterally, carrying its wheel  $L$  more or less into gear with the worm.

I pivot the furrowing-shares across the axis of the tube at the top on each side, and hold them in position by wooden brake-pins  $V$ , the share being kept from displacement forward by the iron stud  $W$ .

Owing to the pivoting of the furrow-opening tube  $J$  at each side, in contradistinction to the pivoting, as usual, in front, I am enabled to place the top of the tube in close relation to the grain-spout  $I$ , as the furrow-tube moves at the upper end but little in any direction.

I do not claim, broadly, a seed-hopper so pivoted that it may be swung laterally to throw the gear-wheels which drive the dropper-plate in and out of gear.

What I claim as my invention, and desire to secure by Letters Patent, is—

1. A double-row corn-drill having in combination, first, a main frame mounted on two wheels, which are the ground-wheels of the machine and driving-wheels of the seed-droppers; second, two independent secondary frames, coupled to swing on the axle of the ground-wheels, to each of which secondary frames are rigidly attached all the operative parts of a corn-drill in proper permanent operative relation; and, third, a driving-connection between each ground-wheel and dropper-plate, which swings with the secondary frame, to which it is permanently secured, and preserves an unchanging relation between these two points.

2. The adjustable graduated plates on the main frame for determining the space between the rows without measurement, substantially as specified.

3. The combination, substantially as specified, of the laterally-sliding bearing of the shaft  $O$ , the cranked trigger-shaft, the spring thereof, the trigger, and the fixed cam-surface for acting on the trigger to turn the trigger-shaft, whereby the shaft  $O$  is moved laterally for throwing its pinion either in or out of gear with the ground-wheel of the main frame.

4. The adjustable bearing  $P$  of the driving-shaft  $O$ , in combination with the pivoted hopper, shiftable toward and from the gear driving its dropper-plate, and the clamping screw or screws, substantially as and for the purpose specified.

In testimony of which invention I hereunto set my hand.

JESSE P. FULGHAM.

Witnesses:

JOHN E. JONES,  
J. L. WARTMANN.