

(19) World Intellectual Property Organization  
International Bureau



(43) International Publication Date  
21 January 2010 (21.01.2010)

PCT

(10) International Publication Number  
**WO 2010/008499 A1**

(51) International Patent Classification:  
F21V 1/00 (2006.01)

(21) International Application Number:  
PCT/US2009/003900

(22) International Filing Date:  
30 June 2009 (30.06.2009)

(25) Filing Language: English

(26) Publication Language: English

(30) Priority Data:  
12/173,149 15 July 2008 (15.07.2008) US

(71) Applicant (for all designated States except US): **RUUD LIGHTING, INC.** [US/US]; 9201 Washington Avenue, Racine, WI 53406 (US).

(72) Inventor; and

(75) Inventor/Applicant (for US only): **WILCOX, Kurt, S.** [US/US]; 140 W. Sunnyside Place, Libertyville, IL 60048 (US).

(74) Agents: **FENSTER, Tatstsana, V. et al.**; 245 Main Street, Racine, WI 53403 (US).

(81) Designated States (unless otherwise indicated, for every kind of national protection available): AE, AG, AL, AM, AO, AT, AU, AZ, BA, BB, BG, BH, BR, BW, BY, BZ, CA, CH, CL, CN, CO, CR, CU, CZ, DE, DK, DM, DO, DZ, EC, EE, EG, ES, FI, GB, GD, GE, GH, GM, GT, HN, HR, HU, ID, IL, IN, IS, JP, KE, KG, KM, KN, KP, KR, KZ, LA, LC, LK, LR, LS, LT, LU, LY, MA, MD, ME, MG, MK, MN, MW, MX, MY, MZ, NA, NG, NI, NO, NZ, OM, PE, PG, PH, PL, PT, RO, RS, RU, SC, SD, SE, SG, SK, SL, SM, ST, SV, SY, TJ, TM, TN, TR, TT, TZ, UA, UG, US, UZ, VC, VN, ZA, ZM, ZW.

(84) Designated States (unless otherwise indicated, for every kind of regional protection available): ARIPO (BW, GH, GM, KE, LS, MW, MZ, NA, SD, SL, SZ, TZ, UG, ZM, ZW), Eurasian (AM, AZ, BY, KG, KZ, MD, RU, TJ, TM), European (AT, BE, BG, CH, CY, CZ, DE, DK, EE, ES, FI, FR, GB, GR, HR, HU, IE, IS, IT, LT, LU, LV, MC, MK, MT, NL, NO, PL, PT, RO, SE, SI, SK, TR), OAPI (BF, BJ, CF, CG, CI, CM, GA, GN, GQ, GW, ML, MR, NE, SN, TD, TG).

Published:

— with international search report (Art. 21(3))

(54) Title: LIGHT-DIRECTING APPARATUS WITH PROTECTED REFLECTOR-SHIELD AND LIGHTING FIXTURE UTILIZING SAME

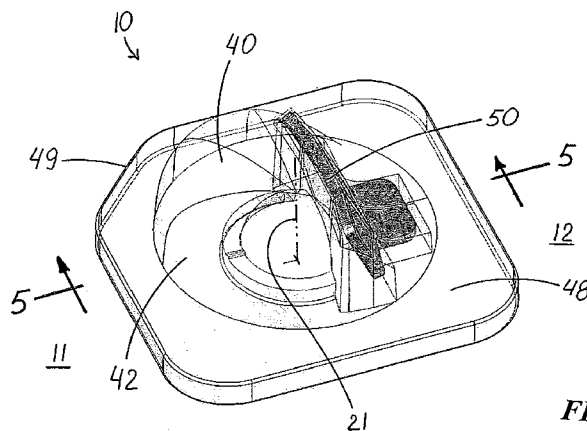


FIG. 1

(57) Abstract: A light-directing apparatus (10) for off-axial preferential-side distribution of light from a light emitter (20) having an emitter axis (21), including a lensing member (40) positioned over the light emitter a shield member (50) embedded within the lensing member in a position in the path of light emitted toward a non-preferential side (12). The lensing member having a proximal end (41) substantially transverse the emitter axis and an outer surface (42) configured for refracting light from the emitter. The shield member may be snugly received in a shield-receiving void (46) of an inner surface (45) of the lensing member. Alternatively, the shield member is embedded by the lensing member having been molded thereabout. Another aspect of this invention is a lighting fixture (30) utilizing such light-directing apparatus.

WO 2010/008499 A1

**LIGHT-DIRECTING APPARATUS  
WITH PROTECTED REFLECTOR-SHIELD  
AND LIGHTING FIXTURE UTILIZING SAME**

5     FIELD OF THE INVENTION

The invention relates generally to the field of lighting systems and, more particularly, to apparatus for utilizing LED light sources for illuminating areas with predefined patterns of light intensity.

10    BACKGROUND OF THE INVENTION

There is a continuing need for lighting apparatus which is low-cost and energy efficient. LEDs (light-emitting diodes) provide light sources which are energy efficient, and advances in LED technology are providing even greater efficiencies over time.

15           Some of the newer applications for LED-based lighting systems are roadway and parking lot lighting in which there are desired performance characteristics and/or with respect to light distribution. More specifically, it is desirable that certain regions generally beneath a light fixture be illuminated, while certain neighboring regions are essentially non-illuminated. Along roadways and in parking lots, there is a need to be  
20    able to direct light in a particular preferential lateral direction (*e.g.*, to illuminate a roadway) while avoiding so-called "trespass light" in an opposite lateral direction (a non-preferential lateral direction), *e.g.*, toward roadside houses.

The importance of avoiding trespass light (or the like) is such that in some cases sacrifices are made in lighting efficiency, by virtue of allowing absorption of  
25    light by shielding members. It would be highly desirable to provide a high-efficiency LED lighting system for roadways, parking lots and the like that avoids trespass light without significant efficiency losses.

It would be further desirable to provide a lighting fixture that maintains the desired light-directing characteristics and efficiency of operation at a substantially  
30    constant level throughout the fixture life. Such continued combination of advantages can be difficult to achieve because of susceptibility of light-managing components to damage, degradation and wear over a period of time.

## OBJECTS OF THE INVENTION

It is an object of this invention to provide a light-directing apparatus and lighting fixture, preferably LED-based devices, which distribute light from light emitters in a preferential lateral direction and which overcomes some of the problems and shortcomings of the prior art.

Another object of this invention is to provide light-directing apparatus and lighting fixture which maximize the light directed toward a preferential side and minimize light directed toward the opposite (non-preferential) side.

Another object of this invention is to provide lighting fixtures for uses such as roadway and parking-lot illumination that have high-efficiency light-directing apparatus while satisfying requirements for minimizing trespass light.

Still another object of this invention is to provide a light-directing apparatus which directs a maximum amount of emitted light toward an area intended to be illuminated.

Yet another object of this invention is to provide an LED-based light-directing apparatus which maintains the light-directing characteristics at a substantially constant level throughout its life.

Another object of this invention is to provide an LED-based light-directing apparatus having light-managing components which are protected from damage, degradation and wear over an extended period of time, even in difficult use environments.

These and other objects of the invention will be apparent from the following descriptions and the drawings.

## SUMMARY OF THE INVENTION

One aspect of the present invention is an improved light-directing apparatus for off-axial preferential-side distribution of light from a light emitter which has an emitter axis. Another aspect of this invention is a lighting fixture utilizing such light-directing apparatus.

The inventive light-directing apparatus includes a lensing member positioned over the light emitter and a shield member. The lensing member has a proximal end

substantially transverse the emitter axis and an outer surface configured for refracting light from the emitter.

The shield member may be embedded within the lensing member in a position in the path of light emitter toward the non-preferential side. The shield member is  
5 embedded by the lensing member having been molded thereabout.

In some preferred embodiments, the proximal end defines a shield-insertion opening. In such embodiments, the lensing member further includes an inner surface defining an off-axis shield-receiving void extending from the shield-insertion opening. The shield member is snugly received in the shield-receiving void in a position in the  
10 path of light emitted toward a non-preferential side. The positioning of the shield-receiving void and the shield member therein are preferably such that the shield is off-set from the emitter axis.

The proximal end of the lensing member may further define an emitter-insertion opening and the inner surface defines an emitter-receiving void extending  
15 from the emitter-insertion opening and facing the emitter. The shield-insertion opening and the emitter-receiving opening are preferably in communication and form a single proximal-end opening. The shield-receiving void is preferably contiguous with the emitter-receiving void. The lensing member is most typically bilaterally symmetric, as is the shield member.

The outer surface of the lensing member is preferably a compound surface  
20 configured for refracting light from the emitter in a predominantly off-axial direction toward a preferential side. One type of a compound outer surface is disclosed in a co-pending United States patent application Serial No. 11/695,483, the contents of which are incorporated herein by reference. The term "compound surface," as used herein  
25 with respect to the outer surface of a lensing member (a lens), means a surface having portions of differing geometric shapes and/or including inflection regions between different portions thereof, *e.g.*, convex portions on either side of a concave portion. "Compound surface" does not imply any particular shape, but the shape will be chosen for the desired lensing properties.

In preferred embodiments, the shield member includes a reflective front  
30 surface in the path of light emitted toward the non-preferential side to redirect such

light toward the preferential side. The shield member may be formed of various plastic materials with a reflective coating. Such coated plastics are known to have a light-reflecting efficiency of about 85%. A still more efficient alternative is an anodized metal, such as aluminum, which provides a higher light-reflection efficiency, of about 95%.

The reflective front surface is preferably entirely within the lensing member. Such enclosure provides highly desirable protection for the reflective surface, virtually eliminating damage, degradation and wear from exposure to elements.

The reflective front surface of the shield member is preferably of non-planar configuration. In some embodiments, the reflective front surface may have a plurality of sections angled with respect to each other. The sections may each be substantially planar. Alternatively, the reflective front surface may be formed by a single section, which may be flat or curved. The exact configuration of the shield portion, and its reflective front surface, whether it is planar or has a radius of curvature, are chosen to achieve the desired light-emitting characteristic for whatever product is being developed.

In preferred embodiments, the shield member includes a shield portion and a base portion. The reflective front surface is on the shield portion that extends from the base portion into the path of light emitted toward the non-preferential side. The base portion extends from the shield portion away from the light emitter at the proximal end of the lensing member.

In preferred embodiments of the inventive light-directing apparatus, the light emitter is an LED package which includes at least one LED and a primary lens over the LED. In such embodiments, the lensing member is a secondary lens placed over the primary lens, and the reflective front surface faces the primary lens. In some other embodiments, there is space between the primary and secondary lenses and the space is filled with optical-grade gel. In preferred embodiments, the primary lens is substantially rotationally symmetrical around the emitter axis; preferably the primary lens is substantially hemispherical.

The term "LED package" is well known in the industry. LED packages have either a single light-emitting diode (LED) or a few closely-spaced LEDs on a base.

Many LED packages include a primary reflector, which may be in the form of a so-called reflector cup mounted to the base or a reflective surface associated with the primary lens proximal the LED(s). One example of LED packages illustrated here in connection with the present invention includes a ring, preferably made of aluminum, around the primary lens on the base, which ring serves to position the primary lens and to reflect some light from the emitter to assist in the generation of an illumination pattern. Persons skilled in the art will appreciate that a broad variety of available LED packages are useful with the light-directing apparatus of the present invention.

The lensing member preferably includes an outward flange around the opening(s) at the proximal end. The flange has an inner surface facing the mounting board. The base portion of the shield member is preferably at least partially against the inner surface of the flange. The outward flange may include a reference mark indicating an orientation with respect to the preferential side. Alternatively, the flange may have a specific shape, such as cut corners or the like, to indicate the orientation with respect to the preferential side. Such features are helpful in assembly of lighting fixtures using such light-directing apparatus.

The lighting fixture of this invention utilizes a plurality of light emitters, preferably LED packages, spaced from one another on a mounting board and oriented with substantially parallel axes. A light-directing apparatus is positioned over the light emitters for off-axial preferential-side distribution of light from the emitters. The light-directing apparatus includes a plurality of lenses, each positioned over one light emitter, and a plurality of shield members. Each lens has a proximal end transverse the emitter axis and defines a shield-insertion opening. Each lens has an inner surface defining an off-axis shield-receiving void extending from the shield-insertion opening, and a compound outer surface configured for refracting light from the emitter in a predominantly off-axial direction toward a preferential side. Each shield member is snugly received in the shield-receiving void of a corresponding one of the lenses in a position in the path of light emitted from the corresponding light emitter toward a non-preferential side.

In some embodiments of the inventive lighting fixture, the lenses have preferential sides in the same lateral direction, thereby to facilitate illumination toward one lateral direction.

5 In other embodiments, the lenses have preferential sides in different lateral directions, thereby to facilitate illumination in different lateral directions. The lenses may be arranged in a substantially circular pattern, and each lens has a preferential side oriented in a substantially radially outward direction with respect to the circular pattern. Some of such other embodiments may have subsets of the emitters and the corresponding lenses, with the subsets configured for directing light in different lateral  
10 directions.

One example of such other embodiments may have two subsets, one subset with its light-directing apparatuses configured for directing light toward a broad area (*e.g.*, of a parking lot), and another smaller subset with its light-directing apparatuses configured for illumination of an adjacent sidewalk. In some other examples of the  
15 above-described embodiments, the emitters and their corresponding lenses are arranged in a substantially circular pattern, with each lens having a preferential side oriented in a substantially radially outward direction with respect to the circular pattern.

In the preferred embodiment, which are illustrated, each lensing member  
20 (secondary lens) is a separate piece. In certain other embodiments, the plurality of lenses in the light-directing apparatus may be formed as portions of a single unitary piece, with the lens portions each positioned for proper placement over its corresponding emitter.

The term “preferential side,” as used herein with respect to the light-  
25 distribution direction, means the lateral direction (with respect to the emitter axis) toward which illumination is desired. The term “non-preferential side,” as used herein with respect to the direction of the light distribution, means the lateral direction toward which illumination is not desired. The non-preferential side is typically substantially radially opposite from the preferential side.

30 The term “snugly,” as used herein with respect to positioning of the shield member inside the lensing member, means that inner surface of the lensing member

which defines the shield-receiving void is configured for fitting closely against at least a portion of the shield-member surfaces to support the shield member in substantially fixed position with respect to the emitter axis. In other words, the shield-receiving void and the shield member are configured for a mating relationship sufficient to fix  
5 the position of the shield member with respect to the lensing member, whether or not all surfaces of the shield member are in contact with surfaces of the lensing member.

The term "being in communication," when used in reference to the emitter-insertion opening and the shield-insertion opening, means that the emitter-insertion opening may encompass the entire shield-insertion opening or that such openings may  
10 partially overlap. In either case, the term "being in communication" means that there is no barrier between such openings. (It should be understood that "opening" does not refer to something having volume, while "void" does imply volume.)

#### BRIEF DESCRIPTION OF THE DRAWINGS

15 FIGURE 1 is a perspective view of one embodiment of the light-directing apparatus of the invention, having a shield member inserted into a lensing member.

FIGURE 2 is an opaque perspective view of the lensing member of FIGURE 1. (The lensing member, of course, is light-transmissive rather than opaque as here shown; the opaque view helps in understanding the shape of the outer surface.)

20 FIGURE 3 is a perspective transparent view of the lensing member without the shield member.

FIGURE 4 is a perspective view of the shield member.

FIGURE 5 is a sectional view of the light-directing apparatus, taken along section 5-5 as shown in FIGURE 1.

25 FIGURE 6 is a similar cross-sectional view, but of another embodiment of the light-directing apparatus of this invention, in this case with the shield member embedded within the lensing member.

FIGURE 7 is a front elevation of the light-directing apparatus of FIGURE 1.

30 FIGURE 8 is a left-side view of FIGURE 7, which views the light-directing apparatus from the preferential illumination side.

FIGURE 9 is a right-side view of FIGURE 7, which views the light-directing apparatus from the non-preferential illumination side.

FIGURE 10 is a perspective view from below of the light-directing apparatus of FIGURE 1.

5 FIGURE 11 is a bottom plan view of FIGURE 1.

FIGURE 12 is a front elevation of the light-directing apparatus as shown in FIGURE 2, with the lensing member opaque for viewing purposes and including an emitter used with such lensing member.

10 FIGURE 13 is a right-side view of FIGURE 12, which views the light-directing apparatus from the non-preferential illumination side.

FIGURE 14 is a top plan view of FIGURE 2.

FIGURE 15 is a perspective view from below of a lighting fixture according to the present invention.

FIGURE 15A is an enlarged fragmentary view of FIGURE 15.

15 FIGURE 16 is a reduced bottom plan view of the lighting fixture of FIGURE 15, excluding the pole portion, but showing illumination toward a common lateral direction.

FIGURE 17 is a front elevation of FIGURE 16.

20 FIGURE 18 is a bottom plan view as in FIGURE 16, but of a lighting fixture with illumination toward different radial directions for illumination of a wide area.

FIGURE 19 is a front elevation of FIGURE 18.

FIGURE 20 is a two-dimensional plot of illumination intensity distribution of the inventive light-directing apparatus of FIGURE 1.

25 FIGURE 20A is a two-dimensional plot of illumination intensity distribution, but from a comparable apparatus not incorporating the present invention.

FIGURE 21 is a schematic perspective representation of a pole-mounted lighting fixture in accordance with the present invention, the pole being positioned along the side of a roadway.

30 FIGURE 22 is a perspective view of one type of an LED package with which the light-directing apparatus of this invention is used.

FIGURE 23 is a graphical representation of the illumination pattern of the LED package of FIGURE 22, showing the axially symmetrical light emission which is then modified by the light-directing apparatus of this invention.

5 DETAILED DESCRIPTION OF PREFERRED EMBODIMENTS

FIGURES 1-14 show preferred embodiments of an inventive light-directing apparatus 10 in accordance with this invention for off-axial preferential-side distribution of light from a light emitter 20 which has an emitter axis 21. FIGURES 15-19 illustrate preferred embodiments of another aspect of this invention which is a  
10 lighting fixture 30 utilizing light-directing apparatus 10.

Inventive light-directing apparatus 10 includes a lensing member 40 positioned over light emitter 20 and a shield member 50. As best seen in FIGURES 3, 5 and 7-9, lensing member 40 has a proximal end 41 substantially transverse emitter axis 21 and an outer surface 42 configured for refracting light from emitter 20. In  
15 such embodiments, shield member 50 has been inserted into lensing member 40.

FIGURE 6 shows a light-directing apparatus 10A which is another embodiment of the invention, in this case with shield member 50A embedded within lensing member 40A in a position in the path of light emitter toward the non-preferential side 12. Shield member 50A is embedded in lensing member 40A by  
20 such lensing member having been molded thereabout.

FIGURES 5 and 7-9 illustrate that proximal end 41 of light-directing apparatus 10 defines a shield-insertion opening 43. Lensing member 40 further includes an inner surface 45 which defines an off-axis shield-receiving void 46 extending from shield-insertion opening 43 and terminating at a close end. Shield member 50 is  
25 snugly received in shield-receiving void 46 in a position in the path of light emitted toward non-preferential side 12. As best seen in FIGURES 5 and 7, the positioning of shield-receiving void 46 and shield member 50 therein are such that shield 50 is off-set from emitter axis 21.

As best illustrated in FIGURES 5, 10 and 11, proximal end 41 of lensing  
30 member 40 further defines an emitter-insertion opening 44. Inner surface 45, mentioned above, in addition to defining shield-receiving void 46, further defines an

emitter-receiving void 47 extending from emitter-insertion opening 44 and facing emitter 20. It can be seen that shield-insertion opening 43 and emitter-receiving opening 44 are in communication and form a single proximal-end opening 410. As is further seen in FIGURE 7, shield-receiving void 46 is contiguous with emitter-receiving void 47.

FIGURES 1, 3-14 show outer surface 42 of lensing member 40 as a compound surface configured for refracting light from emitter 20 in a predominantly off-axial direction toward a preferential side 11. Lensing member 40 is shown to be bilaterally symmetric, as is shield member 50.

Shield member 50 includes a reflective front surface 51 in the path of light emitted toward non-preferential side 12 to redirect such light toward preferential side 11. Reflective front surface 51 is entirely within lensing member 40.

FIGURES 1, 4, 10 and 11 show a preferred embodiment in which reflective front surface 51 of shield member 50 is of non-planar configuration. Reflective front surface 51 has a plurality of sections 52 angled with respect to each other. As further seen in FIGURE 4, sections 52 are each substantially planar.

Shield member 50 further includes a shield portion 53 which extends from a base portion 54 into the path of light emitted toward non-preferential side 12. Base portion 54 extends from shield portion 53 away from light emitter 20 at proximal end 41 of lensing member 40. Reflective front surface 51 is on shield portion 53.

FIGURES 5, 6 and 22 illustrate light emitter 20 as an LED package 22 which includes an LED 26 and a primary lens 23 over the LED. As seen in FIGURES 5 and 6, lensing member 40 is a secondary lens placed over primary lens 23, with reflective front surface 51 of shield member 50 generally facing primary lens 23. FIGURES 5, 6 and 22 show primary lens 23 as substantially rotationally symmetrical around emitter axis 21. Primary lens 23 is substantially hemispherical.

LED package 22 shown in FIGURE 22 includes a ring 24 around primary lens 23 on a base 25. Ring 24 serves to position lens 23 and reflect some light from the LED to assist in generation of illumination pattern 28, illustrated in FIGURE 23.

Lensing member 40 includes an outward flange 48 around the opening(s) at proximal end 41. Flange 48, and thus lensing member 40, are secured with respect to

a mounting board 14 which is part of a lighting fixture that includes a plurality of light-directing apparatuses of the sort described. (See FIGURE 15A.) Flange 48 has an inner surface 480 facing mounting board 14 when mounted thereon. (See FIGURES 5 and 7.) Base portion 54 of shield member 50 is shown to be against inner  
5 surface 480 of flange 48. Flange 48 is further shown to have a special shape 49 such as a cut corner, to indicate the orientation with respect to preferential side 11. Such feature is helpful in assembly of lighting fixtures using light-directing apparatus 10.

Lighting fixture 30 shown in FIGURES 15-19 utilizes a plurality of light emitters 20 spaced from one another on mounting board 14 and oriented with  
10 substantially parallel axes. A light-directing apparatus 100 is positioned over light emitters 20 for off-axial preferential-side distribution of light from emitters 20. Light-directing apparatus 100 includes a plurality of lenses each of which is like lensing member 40 and is positioned over one light emitter 20, and each has a shield member 50 associated with it, as described with respect to light-directing apparatuses 10 or  
15 10A. Lenses 40 are arranged in a substantially circular pattern.

FIGURES 16 and 17 illustrate a lighting fixture 30A in which lenses 40 have their preferential sides 11 in the same lateral direction, thereby to facilitate illumination toward one lateral direction. FIGURES 18 and 19 show a lighting fixture 30B in which lenses 40 have their preferential sides 11 oriented in a substantially  
20 radially outward directions with respect to the circular pattern to give broad illumination which is generally symmetrical with respect to fixture 30B, as shown.

While, as illustrated in FIGURES 1-3 and 5-14, lensing members 40 are each separate pieces, it should be recognized that in certain light-fixture uses utilizing a plurality of lensing members 40, such as the fixtures illustrated in FIGURES 15-19,  
25 lensing members 40 could be incorporated into a single formed member with each lens oriented in the desired direction.

Referring now to FIGURE 21, a roadway 13 is schematically illustrated with a light fixture 30C, which is in accordance with this invention, mounted at the top of a light pole 15 installed along roadway 13, with lighting fixture 30C positioned over the  
30 curb, which is illustrated by a curb line 17 (shown in dotted line). The direction arrow marked by reference number 11 indicates a preferential side (toward the roadway),

and the direction arrow marked by reference number 12 points toward the opposite, non-preferential side.

FIGURE 20 illustrates relative intensity distribution 61 by inventive light-directing apparatus 10, demonstrating that a great majority of the light emanating from apparatus 10 is redirected toward the preferential side 11, with no more than a minimal light reaching the non-preferential side 12. In other words, the amount of "trespass light" is minimized.

FIGURE 20A provides a comparison to show the advantaged of the invention. FIGURE 20A is a two-dimensional illumination intensity distribution 62 by single-light-emitter 20 with single primary lens 23 and a secondary lens which is substantially comparable in design to lensing member 40 but for the fact that it does not accommodate an inserted or embedded shield member. The illumination pattern 62 in FIGURE 20A shows, among other things, a greater amount of light toward the non-preferential side 12 than is the case in FIGURE 20, which was generated using the present invention.

Light patterns 61 and 62 were generated using optical ray-tracing software to simulate the illumination intensity emanating from the respective apparatus.

While the principles of this invention have been described in connection with specific embodiments, it should be understood clearly that these descriptions are made only by way of example and are not intended to limit the scope of the invention.

## CLAIMS

1. A light-directing apparatus for off-axial preferential-side distribution of light from a light emitter having an emitter axis, comprising:
- 5           • a lensing member positioned over the light emitter and having:
- a proximal end substantially transverse the emitter axis and defining a shield-insertion opening;
  - an inner surface defining an off-axis shield-receiving void extending from the shield-insertion opening; and
  - 10           • an outer surface configured for refracting light from the emitter in a predominantly off-axial direction toward a preferential side; and
  - a shield member snugly received in the shield-receiving void in a position in the path of light emitted toward a non-preferential side.
- 15           2. The light-directing apparatus of claim 1 wherein the proximal end of the lensing member further defines an emitter-insertion opening and the inner surface defines an emitter-receiving void extending from the emitter-insertion opening and facing the emitter.
- 20           3. The light-directing apparatus of claim 2 wherein the shield-insertion opening and the emitter-receiving opening are in communication and form a single proximal-end opening.
- 25           4. The light-directing apparatus of claim 3 wherein the shield-receiving void is contiguous with the emitter-receiving void.
- 30           5. The light-directing apparatus of claim 1 wherein the shield member includes a reflective front surface in the path of light emitted toward the non-preferential side to redirect such light toward the preferential side.

6. The light-directing apparatus of claim 5 wherein the reflective front surface is entirely within the lensing member.

7. The light-directing apparatus of claim 6 wherein the reflective front surface of the shield member is of non-planar configuration.

8. The light-directing apparatus of claim 7 wherein the reflective front surface of the shield member has a plurality of sections angled with respect to each other.

9. The light-directing apparatus of claim 8 wherein the sections are each substantially planar.

10. The light-directing apparatus of claim 5 wherein the shield member includes a shield portion and a base portion.

15

11. The light-directing apparatus of claim 10 wherein:

- the shield portion extends from the base portion into the path of light emitted toward the non-preferential side;
- the base portion extends from the shield portion away from the light emitter at the proximal end of the lensing member; and
- the reflective front surface is on the shield portion.

20

12. The light-directing apparatus of claim 1 wherein:

- the light emitter is an LED package including at least one LED and a primary lens over the LED;
- the lensing member is a secondary lens placed over the primary lens; and
- the shield member includes a reflective front surface generally facing the primary lens.

25

30

13. The light-directing apparatus of claim 1 wherein the lensing member includes an outward flange around the opening(s) at the proximal end.

5 14. A lighting fixture with a plurality of light emitters spaced from one another on a mounting board, each light emitter having an emitter axis substantially parallel to the axes of the other light emitters, and a light-directing apparatus positioned over the light emitters for off-axial preferential-side distribution of light from the emitters, the light-directing apparatus comprising:

- 10
- a plurality of lenses each positioned over one light emitter and each having:
    - a proximal end transverse the emitter axis; and
    - an outer surface configured for refracting light from the emitter; and
  - a plurality of shield members each disposed within the corresponding lens in a position in the path of light emitted from the corresponding light
- 15 emitter toward a non-preferential side.

15. The lighting fixture of claim 14 wherein each lens is a separate piece.

20 16. The lighting fixture of claim 14 wherein the lenses have preferential sides in the same lateral direction, thereby to facilitate illumination toward one lateral direction.

25 17. The lighting fixture of claim 14 wherein the lenses have preferential sides in different lateral directions, thereby to facilitate illumination in different lateral directions.

18. The lighting fixture of claim 17 wherein:

- the lenses are arranged in a substantially circular pattern; and
- each lens has a preferential side oriented in a substantially radially outward direction with respect to the circular pattern.

5

19. The lighting fixture of claim 14 wherein:

- the proximal end of each lens defines a shield-insertion opening and an emitter-insertion opening; and
- the lens includes an inner surface which defines an off-axis shield-receiving void extending from the shield-insertion opening and an emitter-receiving void extending from the emitter-insertion opening and facing the corresponding emitter.

10

20. The lighting fixture of claim 19 wherein the shield member is snugly received in the shield-receiving void of a corresponding one of the lenses.

15

21. The lighting fixture of claim 14 wherein the shield member is embedded by the lensing member having been molded thereabout.

22. The lighting fixture of claim 14 wherein each shield member includes a reflective front surface in the path of light emitted by the corresponding light emitter toward the non-preferential side to redirect such light toward the preferential side.

20

23. The lighting fixture of claim 22 wherein each reflective front surface is entirely within the corresponding lens.

25

24. The lighting fixture of claim 23 wherein the reflective front surface of each shield member is of non-planar configuration.

25. The lighting fixture of claim 24 wherein the reflective front surface of the shield member has a plurality of sections angled with respect to each other.

30

26. The lighting fixture of claim 25 wherein the sections are each substantially planar.

27. The lighting fixture of claim 14 wherein:

- 5
- each light emitter is an LED package including at least one LED and a primary lens over the LED;
  - each lens is a secondary lens placed over a corresponding primary lens; and
  - each shield member includes a reflective front surface generally facing the
- 10
- primary lens.

28. The lighting fixture of claim 27 wherein each secondary lens is a separate piece.

15

29. A light-directing apparatus for off-axial preferential-side distribution of light from a light emitter having an emitter axis, comprising:

- a lens member positioned over the light emitter and having:
    - a proximal end transverse the emitter axis and defining a shield-insertion opening;
  - an inner surface defining an off-axis shield-receiving void extending
- 20
- from the shield-insertion opening; and
  - an outer surface configured for refracting light from the emitter; and
  - a shield member snugly received in the shield-receiving void in a position in the path of light emitted toward a non-preferential side.

25

30. The light-directing apparatus of claim 29 wherein the shield member includes a reflective front surface in the path of light emitted toward the non-preferential side to redirect such light toward the preferential side.

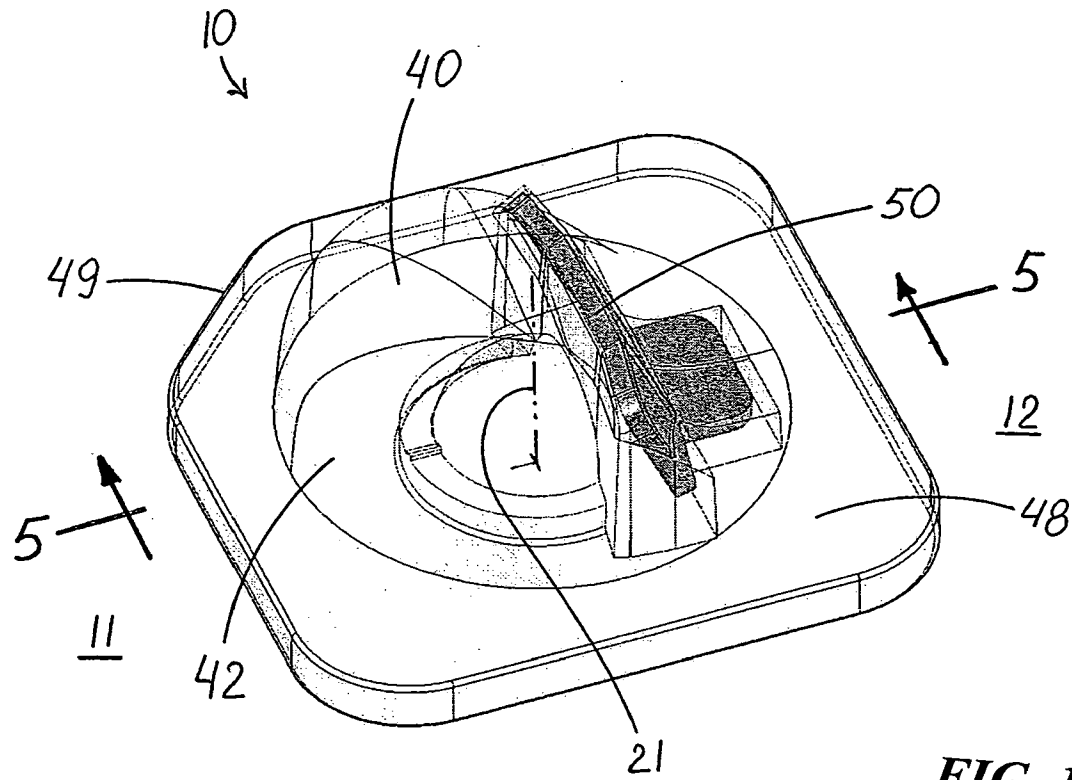
30

31. A light-directing apparatus for off-axial preferential-side distribution of light from a light emitter having an emitter axis, comprising:

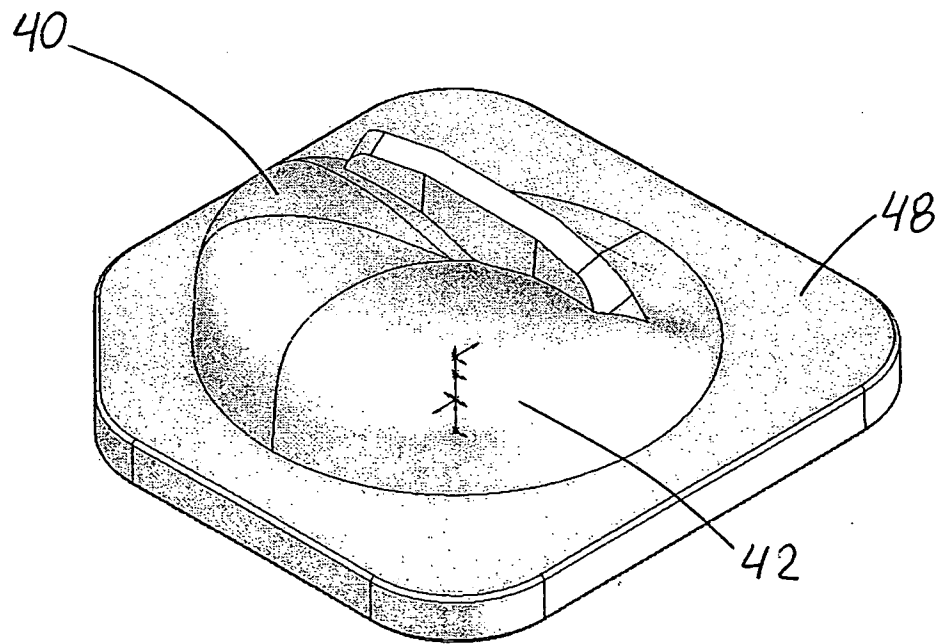
- a lensing member positioned over the light emitter and having:
  - a proximal end substantially transverse the emitter axis; and
  - an outer surface configured for refracting light from the emitter; and
- a shield member embedded within the lensing member in a position in the path of light emitted toward a non-preferential side.

32. The light-directing apparatus of claim 31 wherein the shield member includes a reflective front surface in the path of light emitted toward the non-preferential side to redirect such light toward the preferential side.

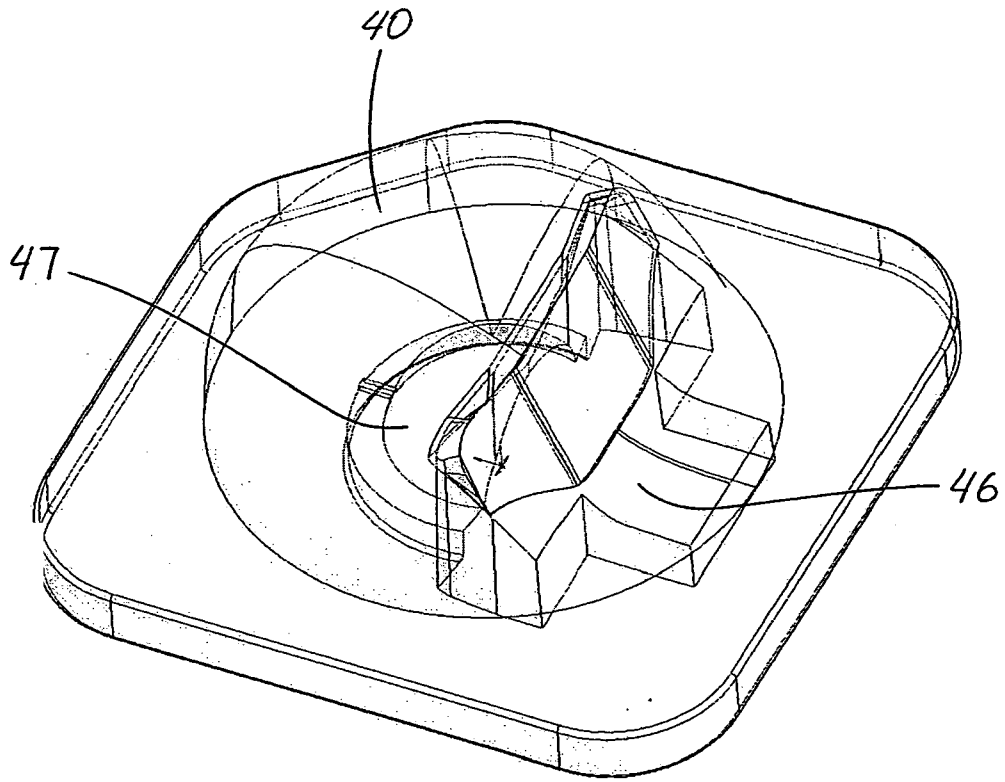
33. The light-directing apparatus of claim 32 wherein the shield member is embedded by the lensing member having been molded thereabout.



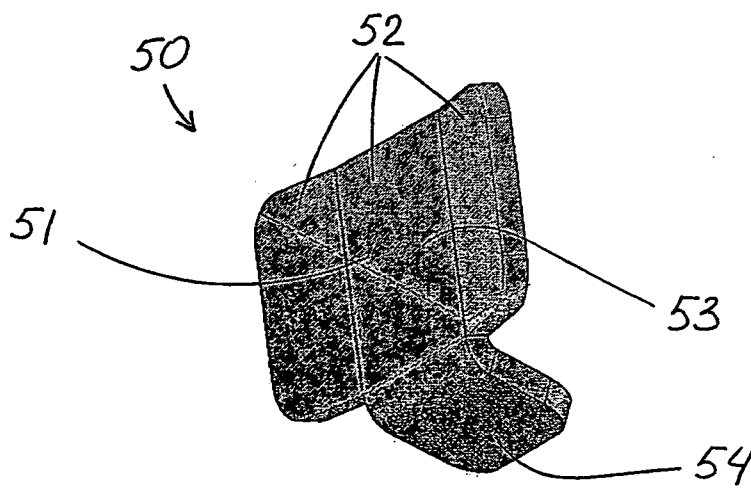
**FIG. 1**



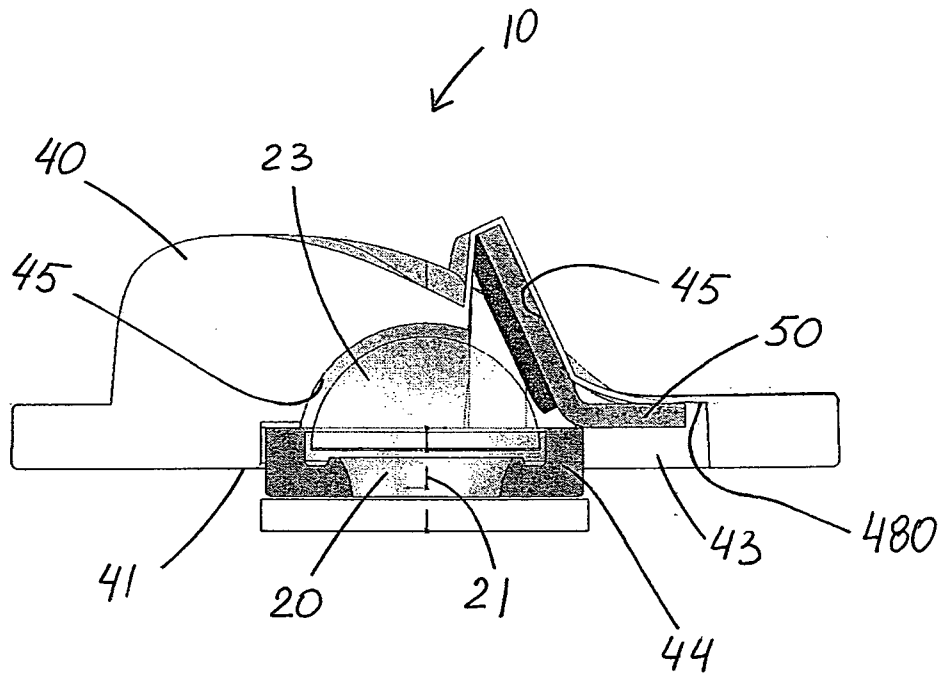
**FIG. 2**



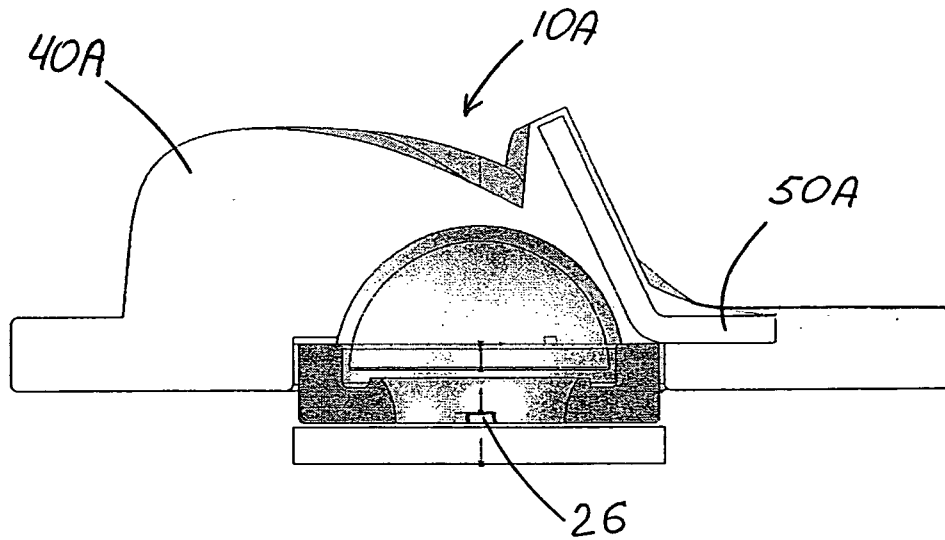
**FIG. 3**



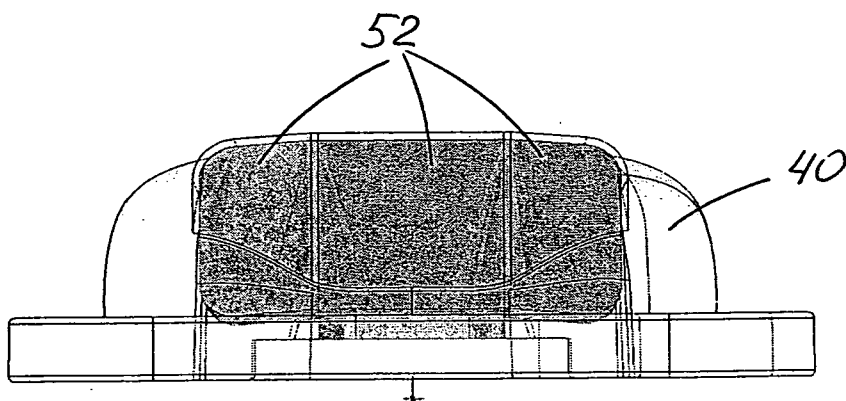
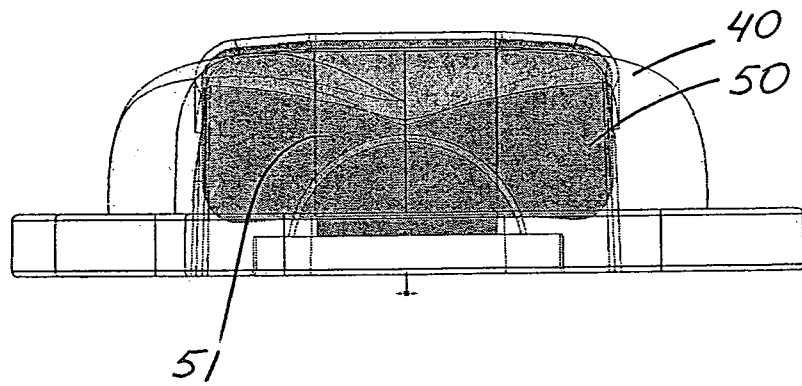
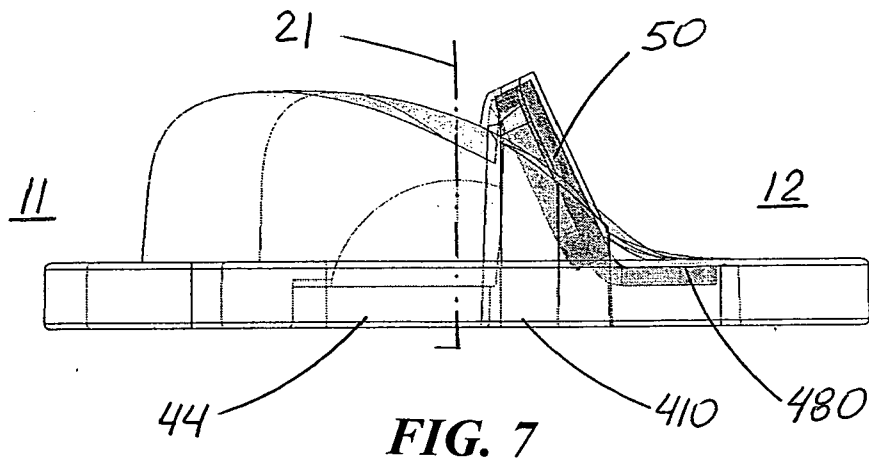
**FIG. 4**

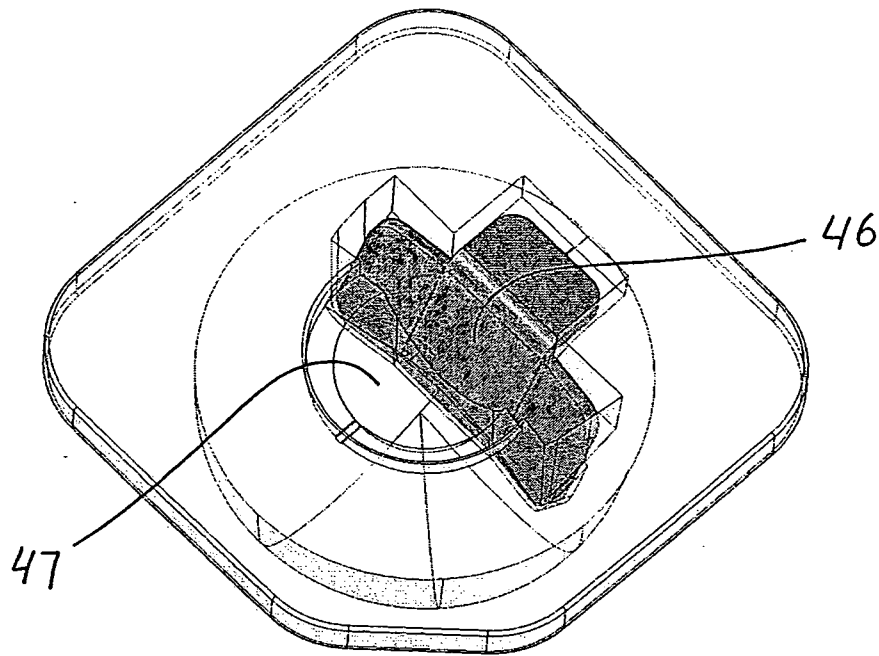


**FIG. 5**

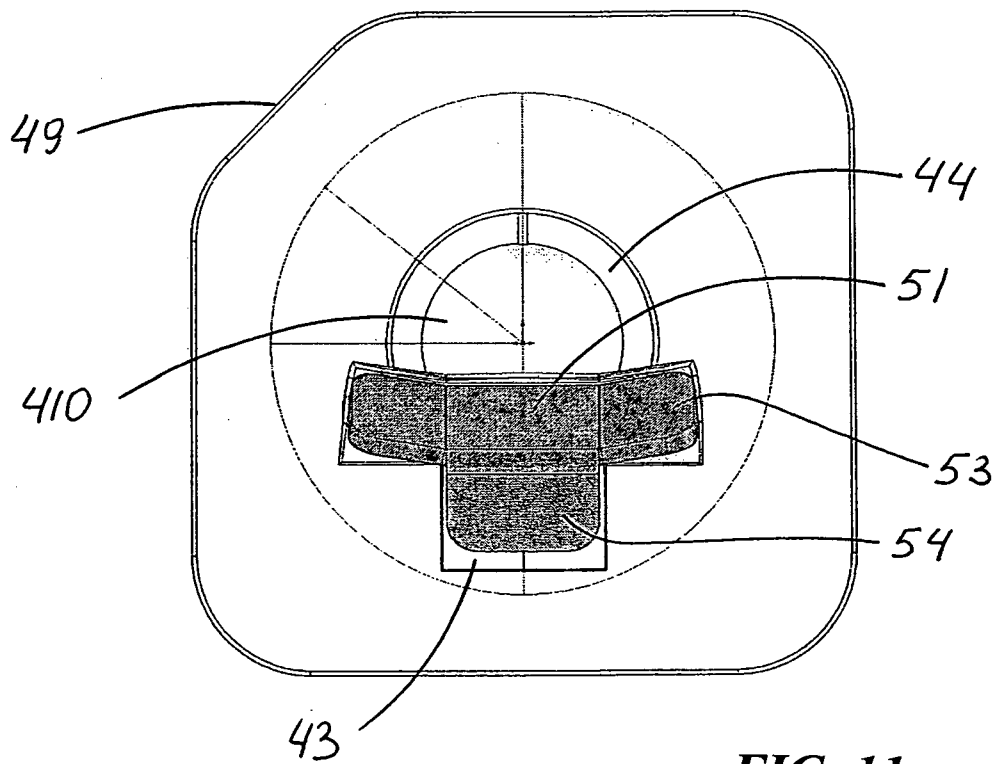


**FIG. 6**

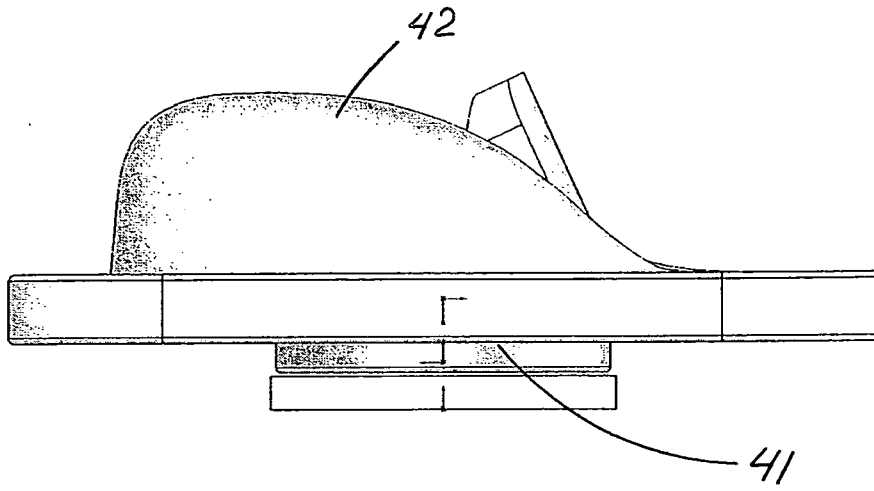




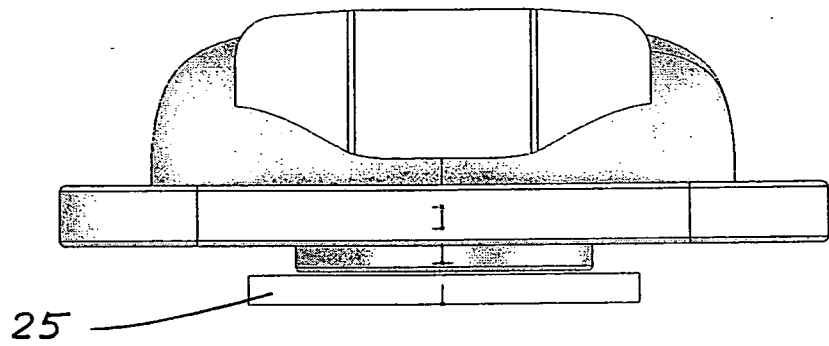
**FIG. 10**



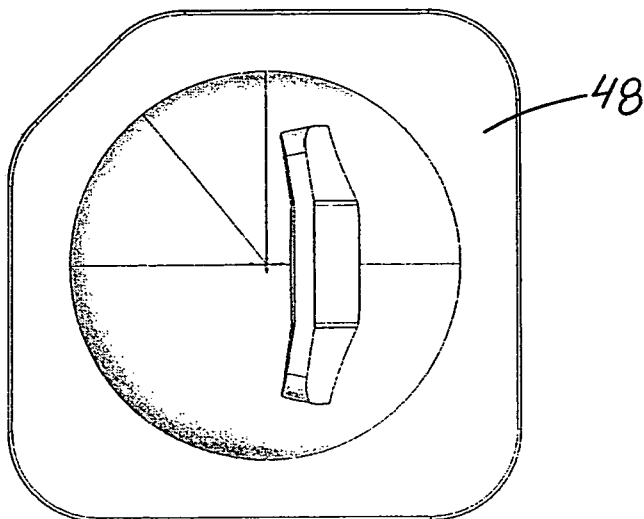
**FIG. 11**



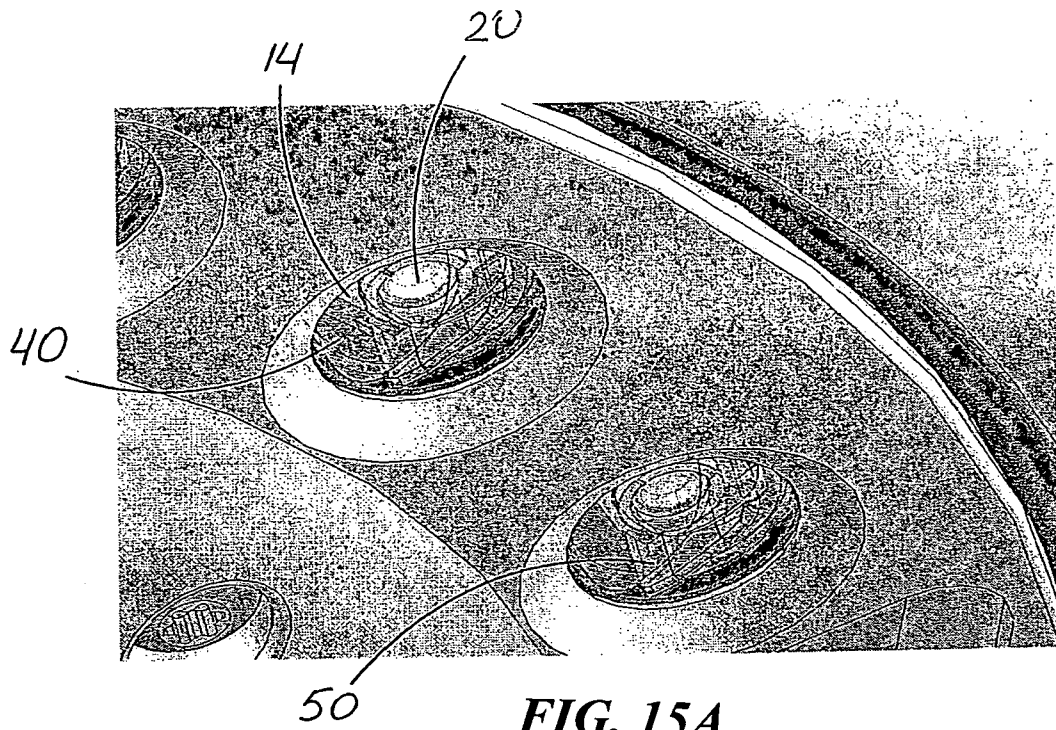
**FIG. 12**



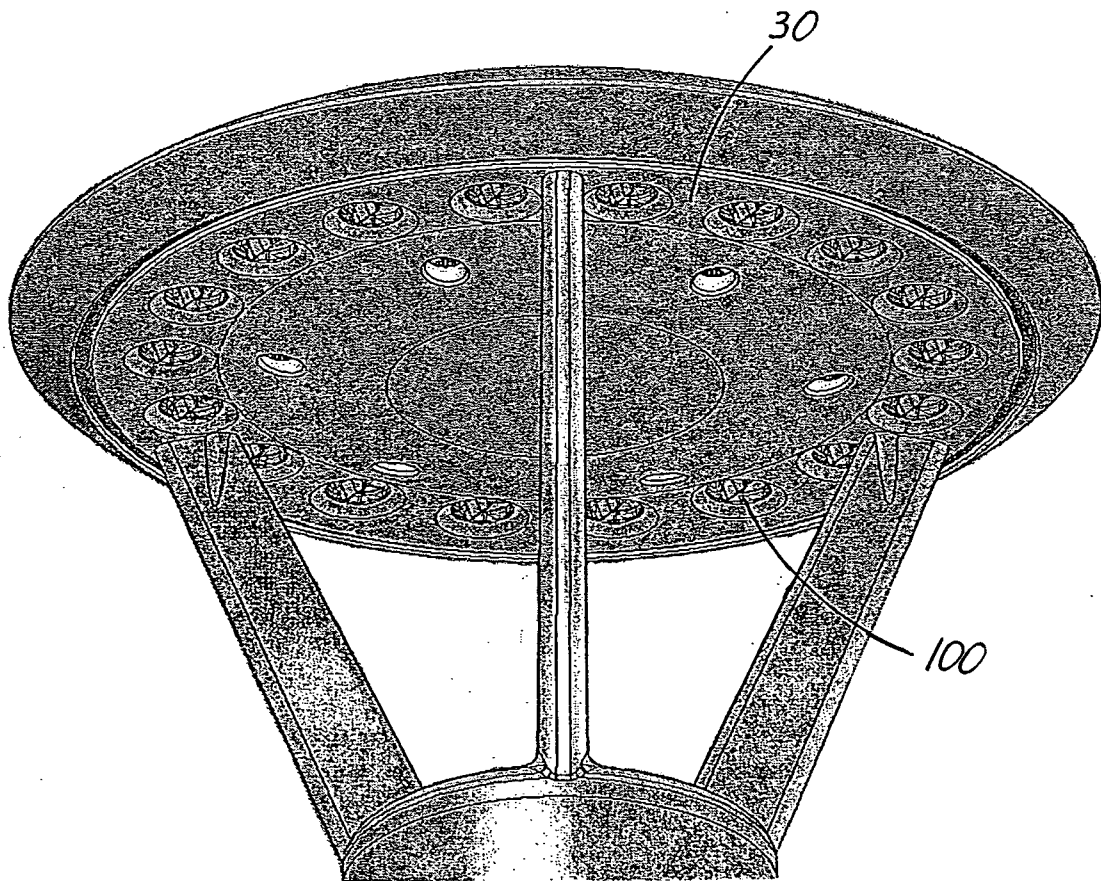
**FIG. 13**



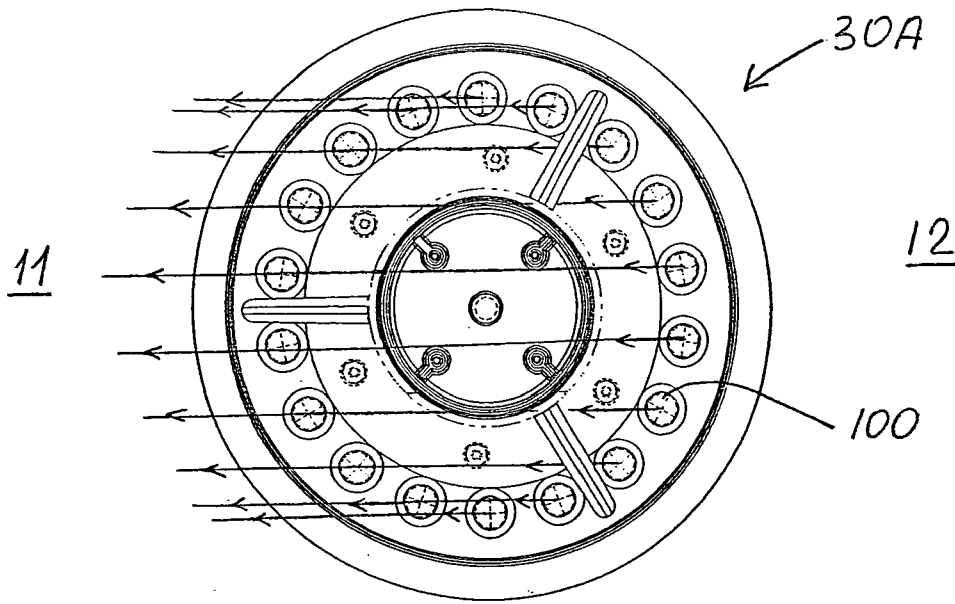
**FIG. 14**



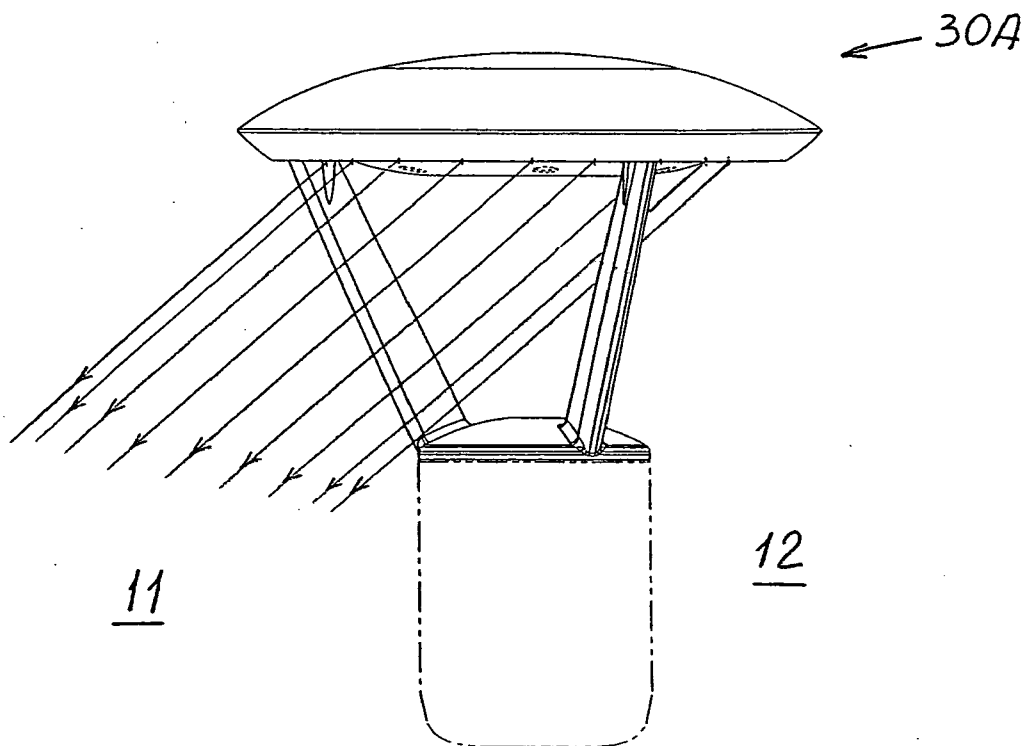
**FIG. 15A**



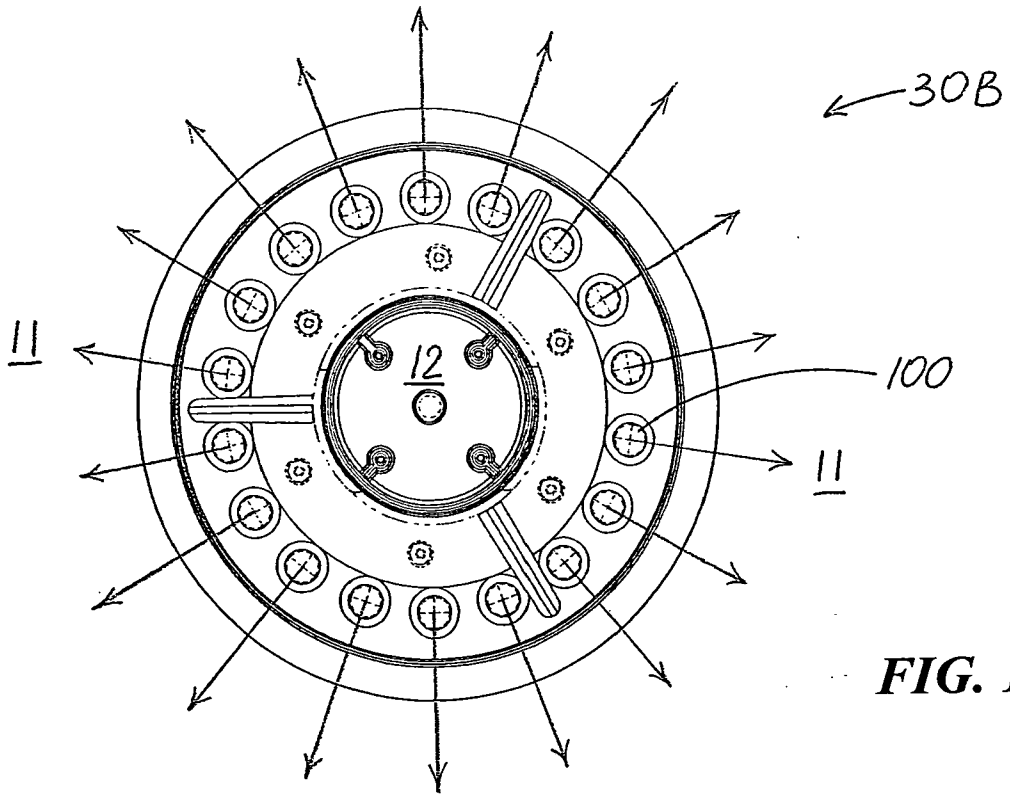
**FIG. 15**



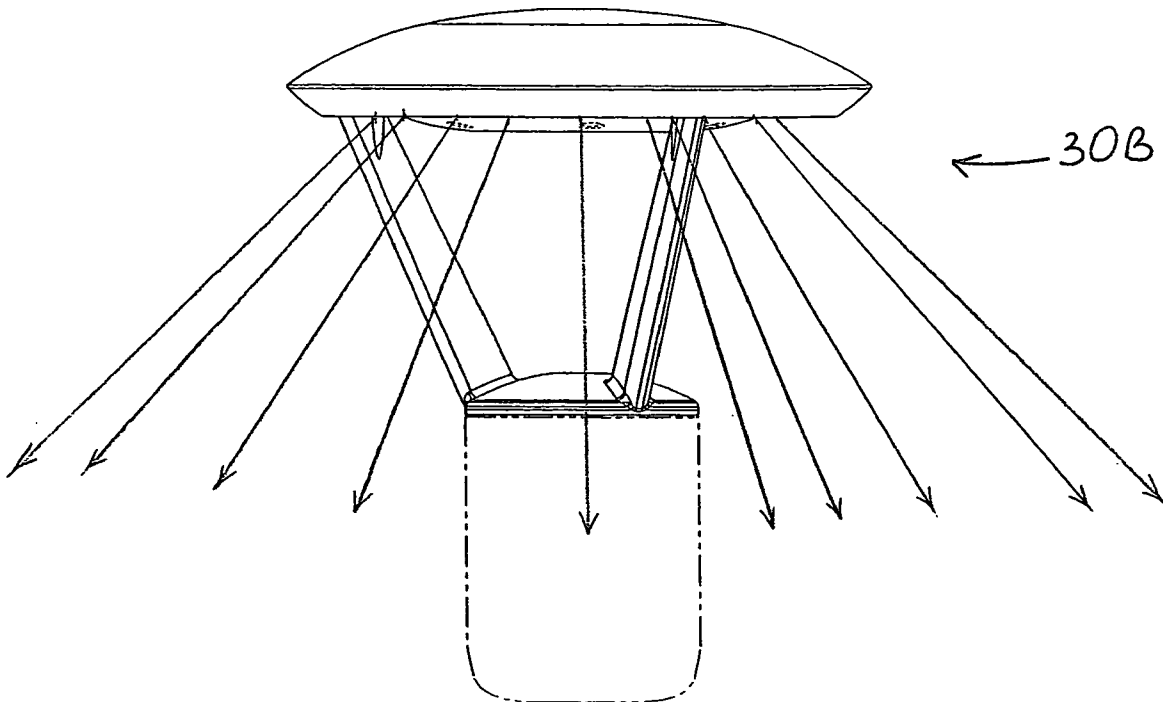
**FIG. 16**



**FIG. 17**



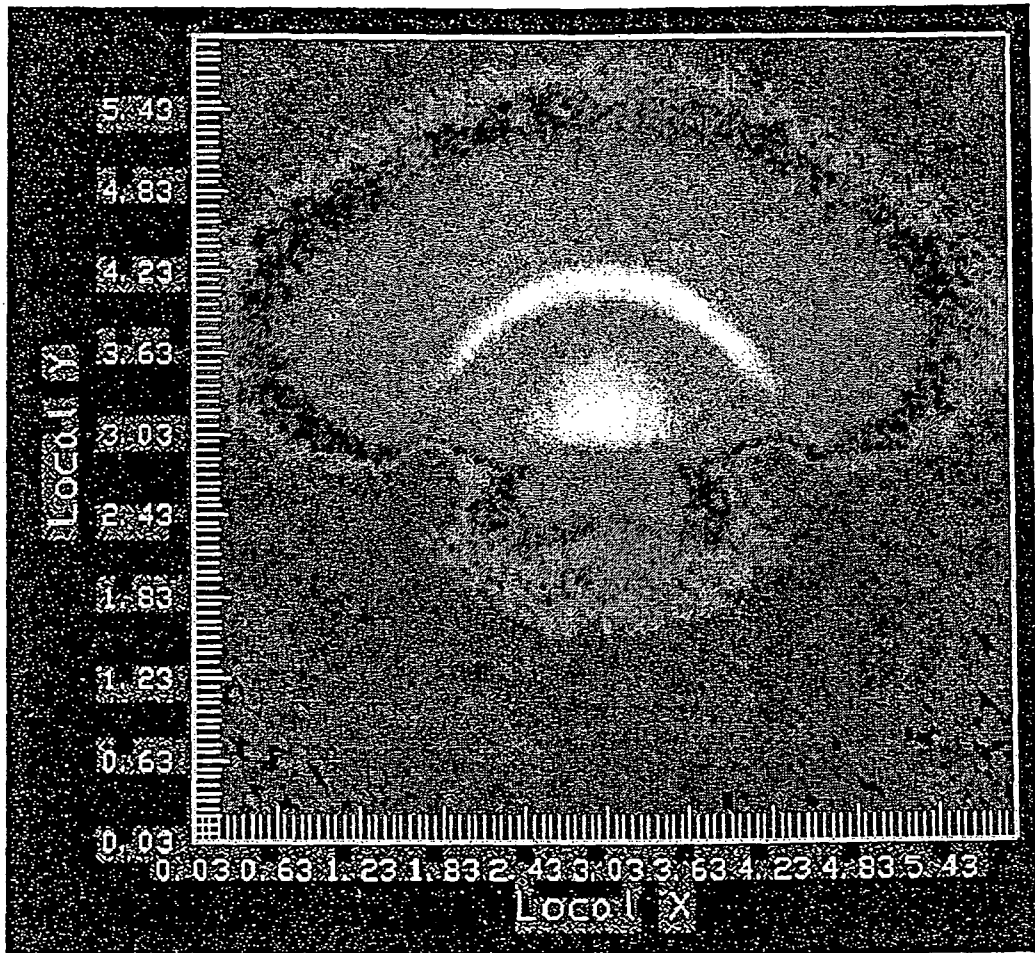
**FIG. 18**



**FIG. 19**

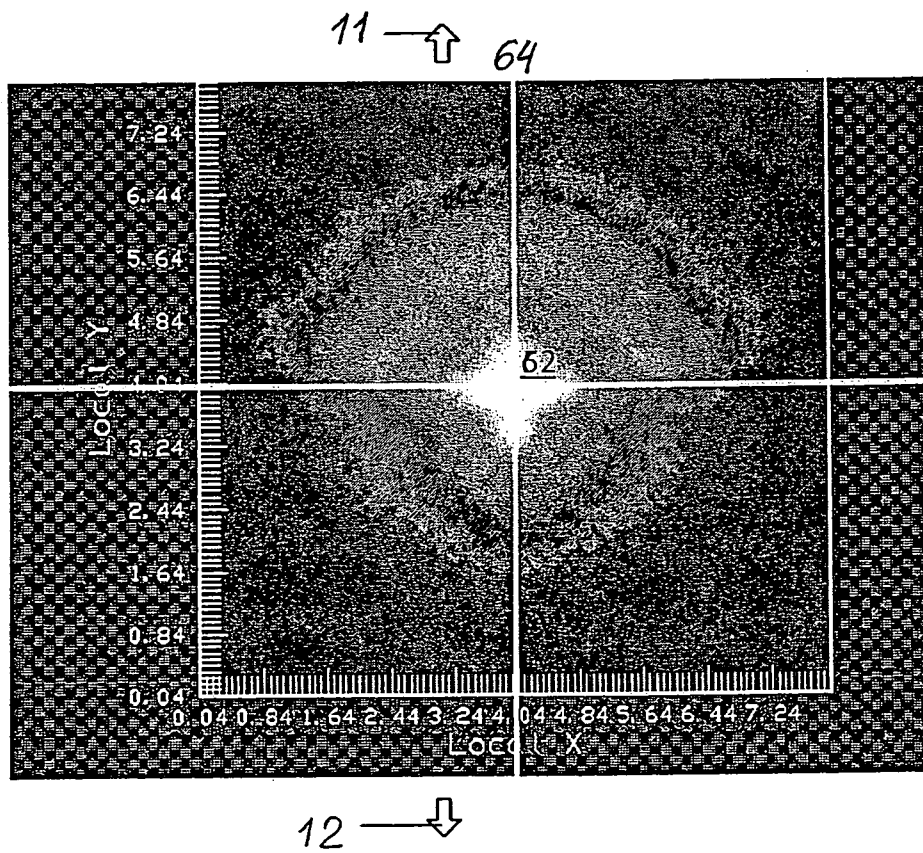
61 →

11



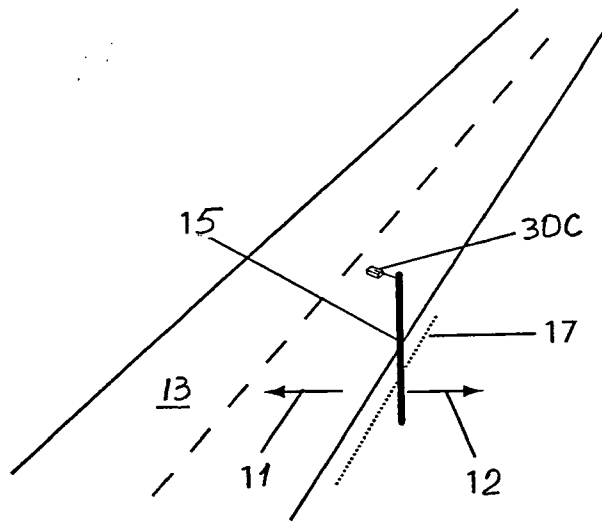
12

**FIG. 20**

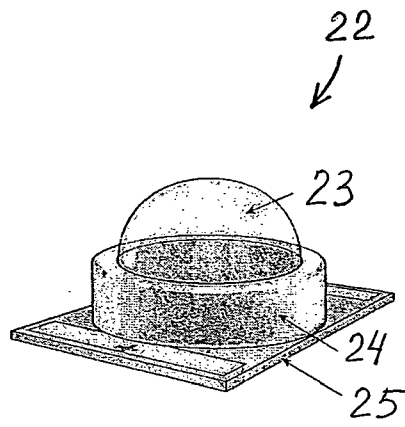


**FIG. 20A**

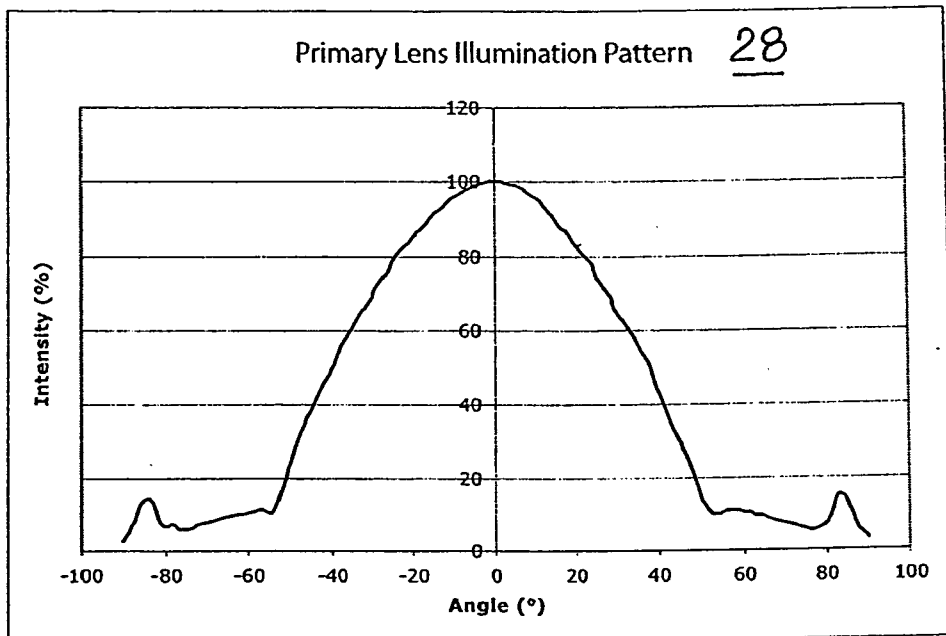
**PLOT OF ILLUMINATION DISTRIBUTION  
FROM A COMPARABLE APPARATUS  
NOT USING THE PRESENT INVENTION**



**FIG. 21**



**FIG. 22**



**FIG. 23**

**INTERNATIONAL SEARCH REPORT**

International application No.  
PCT/US 09/03900

**A. CLASSIFICATION OF SUBJECT MATTER**

IPC(8) - F21V 1/00 (2009.01)

USPC - 362/248

According to International Patent Classification (IPC) or to both national classification and IPC

**B. FIELDS SEARCHED**

Minimum documentation searched (classification system followed by classification symbols)

USPC - 362/248

Documentation searched other than minimum documentation to the extent that such documents are included in the fields searched  
USPC - 362/800,236,245,248,268,317,327 (see search terms below)

Electronic data base consulted during the international search (name of data base and, where practicable, search terms used)

PubWest(PGPB,USPT,EPAB,JPAB), Google Scholar, USPTO

Search Terms: shield, shroud, insert, remove, adjust, LED, shutter, off axis or axial, light, emit\$, source, parking lot, roadway, road, street

**C. DOCUMENTS CONSIDERED TO BE RELEVANT**

Category*	Citation of document, with indication, where appropriate, of the relevant passages	Relevant to claim No.
X ----- Y	US 7,314,296 B2 (Machi et al.) 01 January 2008 (01.01.2008) entire document especially col 8, ln 16-29, col 4, ln 54-67, col 5, ln 59-67, col 9, ln 3-14, Fig. 3A, col 6, ln 42-61, Fig. 1, and col 6, ln 1-9.	1, 5, and 10 ----- 2-4, 6-9, 11-30, 32, and 33
X ----- Y	US 2008/0117646 A1 (Yatsuda et al.) 22 May 2008 (22.05.2008) entire document especially Fig. 2, para [0046]-[0047], para [0052], para [0064], Fig. 4, and para [0062].	31 ----- 2-4, 6-9, 12-30, 32, and 33
Y	US 4,232,359 A (Leon et al.) 04 November 1980 (04.11.1980) entire document especially col 3, ln 60 to col 4, ln 6	11, 19, 20, 29, and 30
Y	US 6,953,265 B2 (Suehiro et al.) 11 October 2005 (11.10.2005) entire document especially Fig. 1, and col 32, ln 57 to col 33, ln 3	17, and 18

Further documents are listed in the continuation of Box C.

* Special categories of cited documents:	"T" later document published after the international filing date or priority date and not in conflict with the application but cited to understand the principle or theory underlying the invention
"A" document defining the general state of the art which is not considered to be of particular relevance	"X" document of particular relevance; the claimed invention cannot be considered novel or cannot be considered to involve an inventive step when the document is taken alone
"E" earlier application or patent but published on or after the international filing date	"Y" document of particular relevance; the claimed invention cannot be considered to involve an inventive step when the document is combined with one or more other such documents, such combination being obvious to a person skilled in the art
"L" document which may throw doubts on priority claim(s) or which is cited to establish the publication date of another citation or other special reason (as specified)	"&" document member of the same patent family
"O" document referring to an oral disclosure, use, exhibition or other means	
"P" document published prior to the international filing date but later than the priority date claimed	

Date of the actual completion of the international search 10 August 2009 (10.08.2009)	Date of mailing of the international search report <b>24 AUG 2009</b>
--	--

Name and mailing address of the ISA/US Mail Stop PCT, Attn: ISA/US, Commissioner for Patents P.O. Box 1450, Alexandria, Virginia 22313-1450 Facsimile No. 571-273-3201	Authorized officer: Lee W. Young  PCT Helpdesk: 571-272-4300 PCT OSP: 571-272-7774
---	--